

Multichannel Interferometer System for the HSX Stellarator

D.L. Brower, C. Deng, W.X. Ding, D.T. Anderson*, and W. Mason*

Electrical Engineering Department, University of California, Los Angeles

**Electrical Engineering Department, University of Wisconsin, Madison*

A multichannel far-infrared interferometer system has been designed, fabricated and installed on the quasi-helical stellarator **HSX**. The interferometer will view the plasma cross section along 9 adjacent chords with 1.5 cm spacing. With this arrangement, coverage will span from the low-field side scrape-off layer to well past the magnetic axis. For the plasma densities anticipated on HSX, a solid-state source operating at 288 GHz will be utilized. At this frequency refraction will be manageable, being much less than the channel spacing. The source will be bias-tuned and modulated with a sawtooth waveform at 750 kHz in order to generate the intermediate frequency necessary for the heterodyne detection scheme. The signals will be detected using Schottky-diode corner-cube mixers. The interferometer will have sensitivity $n_e dl = 8 \times 10^{11} \text{ cm}^{-2}$. Initially, the phase will be evaluated using analog electronics with bandwidth $< 10 \text{ kHz}$ providing real-time line-integrated output. A digital phase comparator scheme will also be implemented whereby the measured waveforms are directly digitized and the phase evaluated using complex demodulation techniques. This will increase the time response up to the modulation frequency of 750 kHz. Improved time response will permit measurement of high-frequency density fluctuations along with the equilibrium profile.

HSX Stellarator

- **Helically Symmetric EXperiment, HSX**
quasi-helically symmetric [QHS] stellarator
major radius: $R=1.2$ m,
average minor radius: $\langle a \rangle = 15$ cm,
 $B_T = 0.5 - 1$ T, $T_e = 1$ keV, and $n_e < 1 \times 10^{13}$ cm⁻³
Heating and breakdown: 28 GHz ECRH, 200 kW
- **Unique toroidal magnetic configuration:** no toroidal curvature and a helical axis of symmetry.
Physics goals:
- Greatly reduced neoclassical transport with respect to other stellarators and comparable tokamaks.
- Reduced anomalous transport by low parallel viscous damping in the direction of symmetry.

Interferometer Capabilities

- **Spatial resolution:** 9 chords, 1.5cm spacing and width.
- **Fast time response:** analog: 100-200 μsec , real time
digital: $<10 \mu\text{sec}$
maximum bandwidth 250 kHz [with 2 MHz sampling]
- **Low phase noise:** 24 mrad (1.6°)
 $(\Delta n_e dl)_{\min} = 8 \times 10^{11} \text{ cm}^{-2}$
0.4% level density fluctuations can be measured
- **Density fluctuations:** wavenumber resolution
(i) $k_{\perp} < 2.1 \text{ cm}^{-1}$, (ii) $k_{\parallel} < 0.07 \text{ cm}^{-1}$

Solid State Source

- **Solid State Source:**
 - (a) varactor-tunable Gunn diode at 72 GHz with two Doublers providing output at 288 GHz (0.7 mW); 5 channels max.
 - (b) bias-tuned Gunn diode at 96 GHz with passive solid-state Tripler providing output at 288 GHz (8 mW); 9 channel operation
- **Support of Optical System:** 2.5 meter tall, 2 ton reaction mass, mounted on structure independent of HSX device. Reduces structure vibration and minimizes phase noise
- **Dichroic Filters:** mounted on port windows to shield interferometer from 28 GHz gyrotron radiation plus,
 - cutoff frequency: 220 GHz ,
 - approximately 10% loss
 - attenuation ranging from 92db at 28 GHz to 68 db at 150 GHz.

Data Acquisition System

- **Analog phase comparator:** PCI-MIO-16E-1, 12 bits resolution, maximum sampling rate 75 kHz for 9 channels
- **Digital phase comparator:** PCI-6110 E, 12 bits resolution, max sampling rate 5 MHz for 10 channels
- **Control and manage :** PC and LabVIEW.

Density Fluctuation Measurement

- 24 mrad RMS phase noise gives density resolution: $\Delta n_e dl = 8 \times 10^{11} \text{ cm}^{-2}$.
- Minimum detectable density fluctuation amplitude: $\Delta n_e / n_e = 2 \times 10^{10} / 5 \times 10^{12} = 0.4 \%$.
- Wavenumber resolution: (a) $k_{\perp} = 2.1 \text{ cm}^{-1}$, (b) $k_{\parallel} = 0.07 \text{ cm}^{-1}$.
- Maximum bandwidth **250 kHz** (sample at 2MHz)

Interferometer Schematic

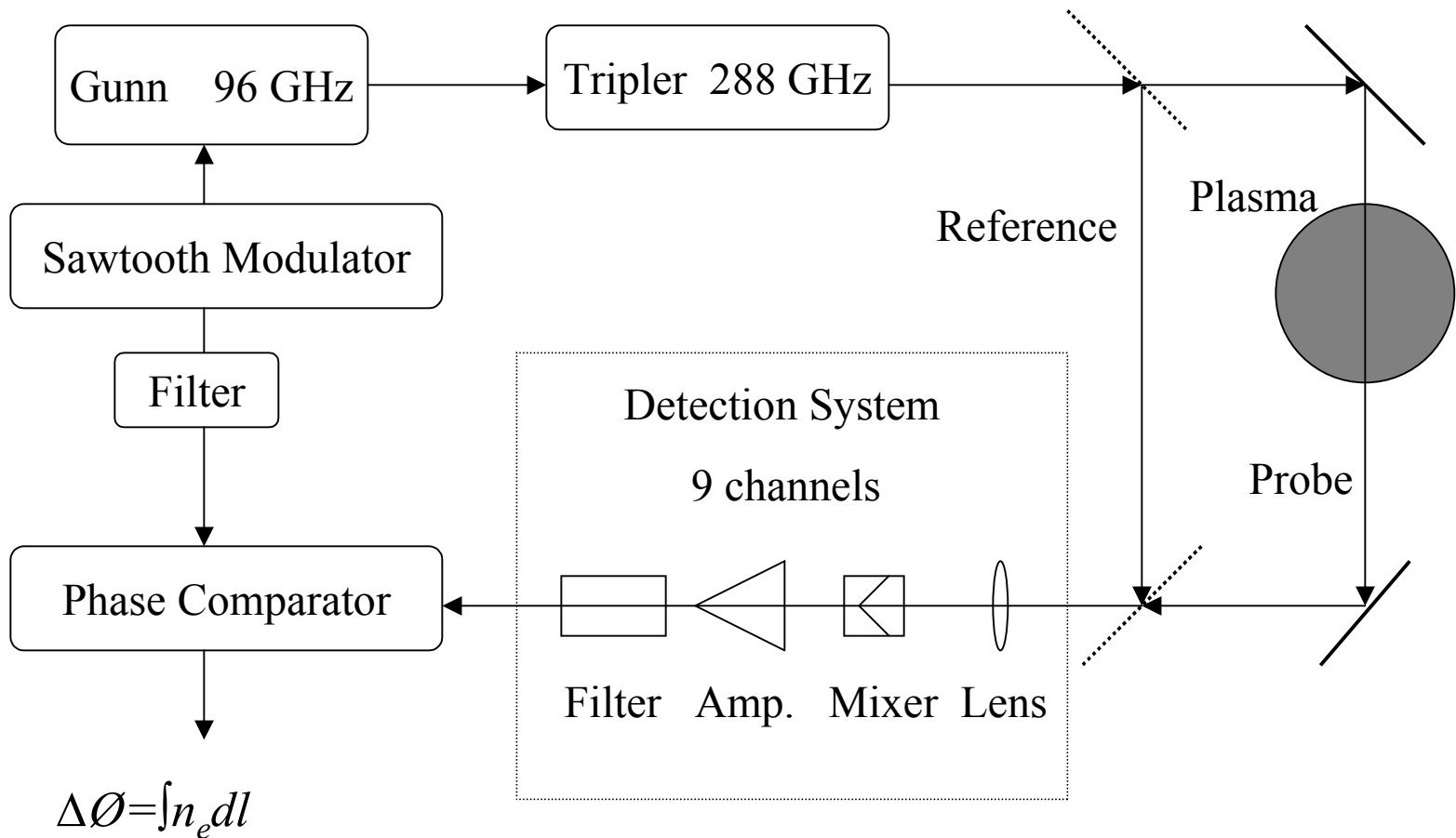

Beam Expansion Optics and Receiver Array

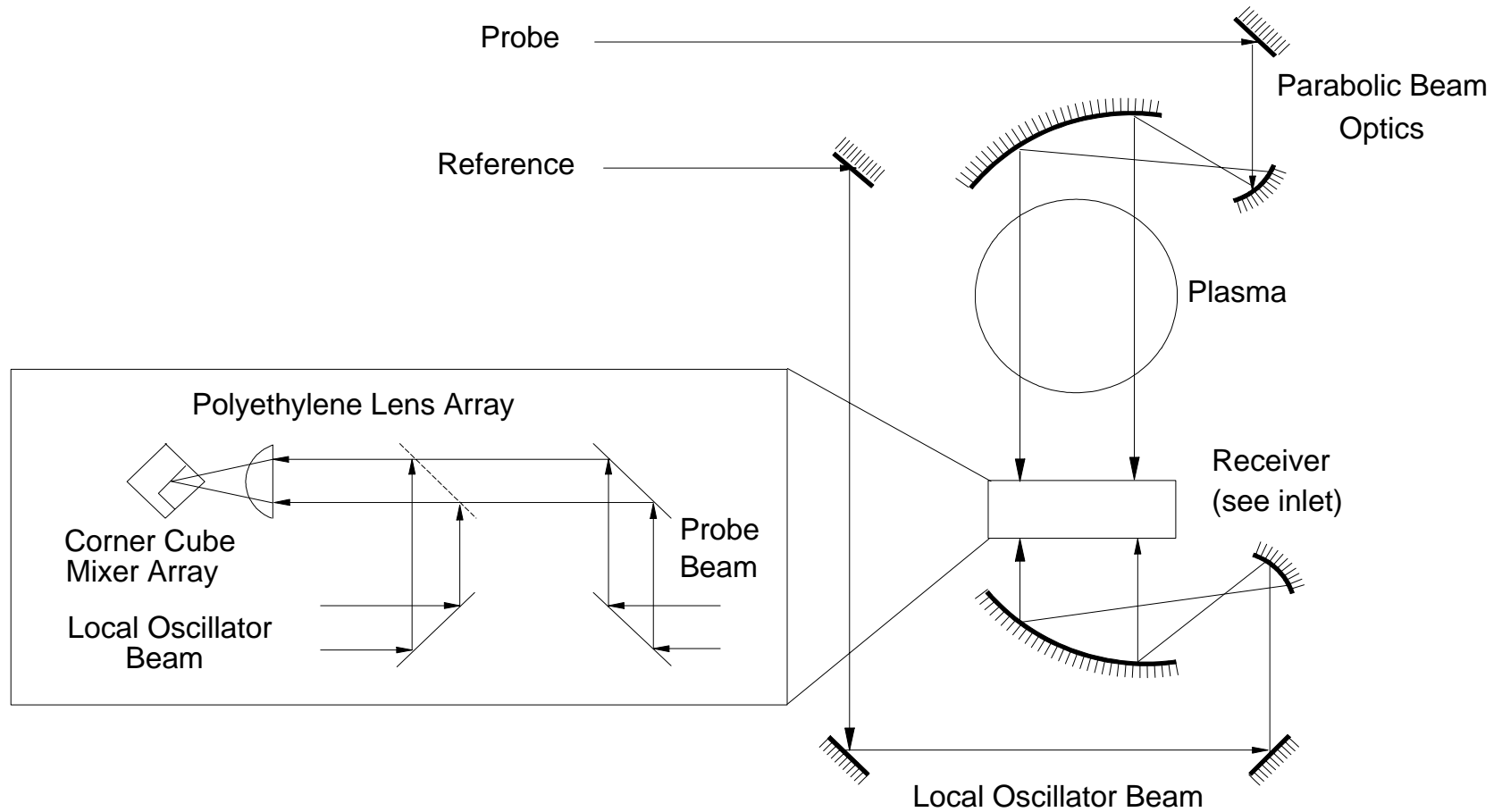

HSX Interferometer Layout

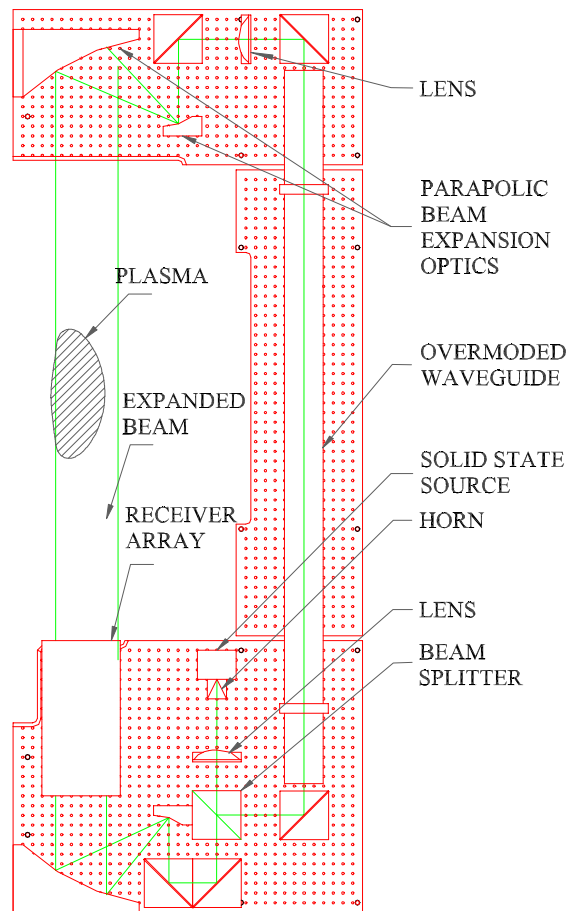

HSX Interferometer System

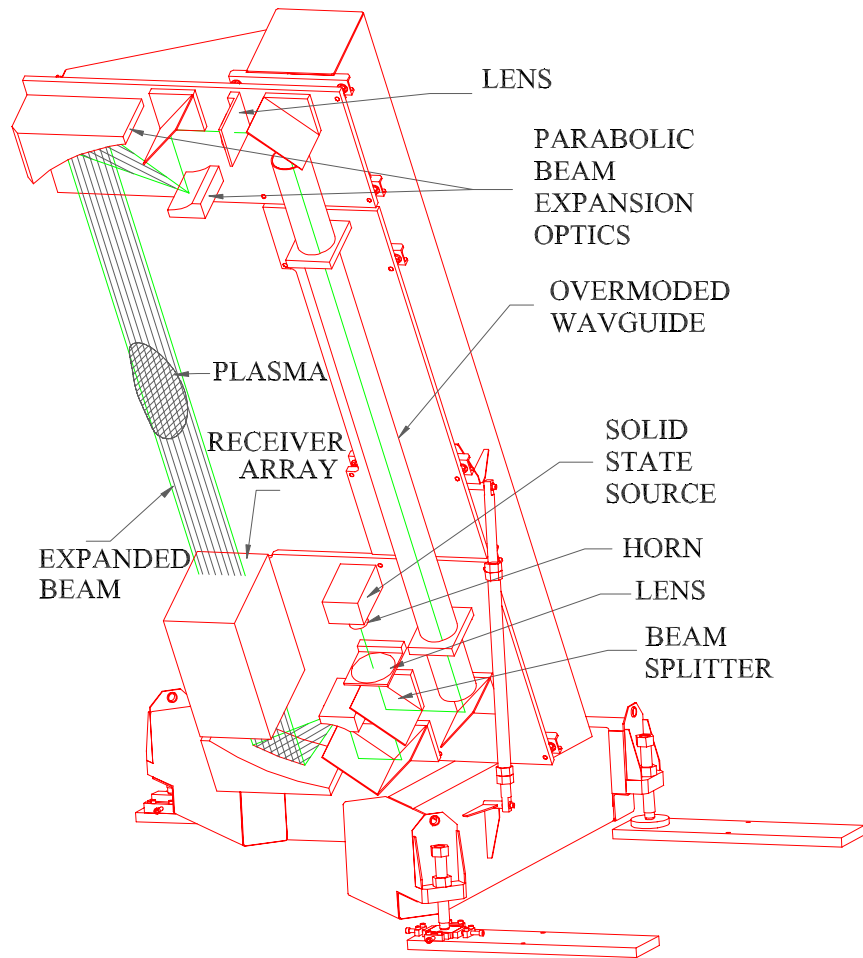

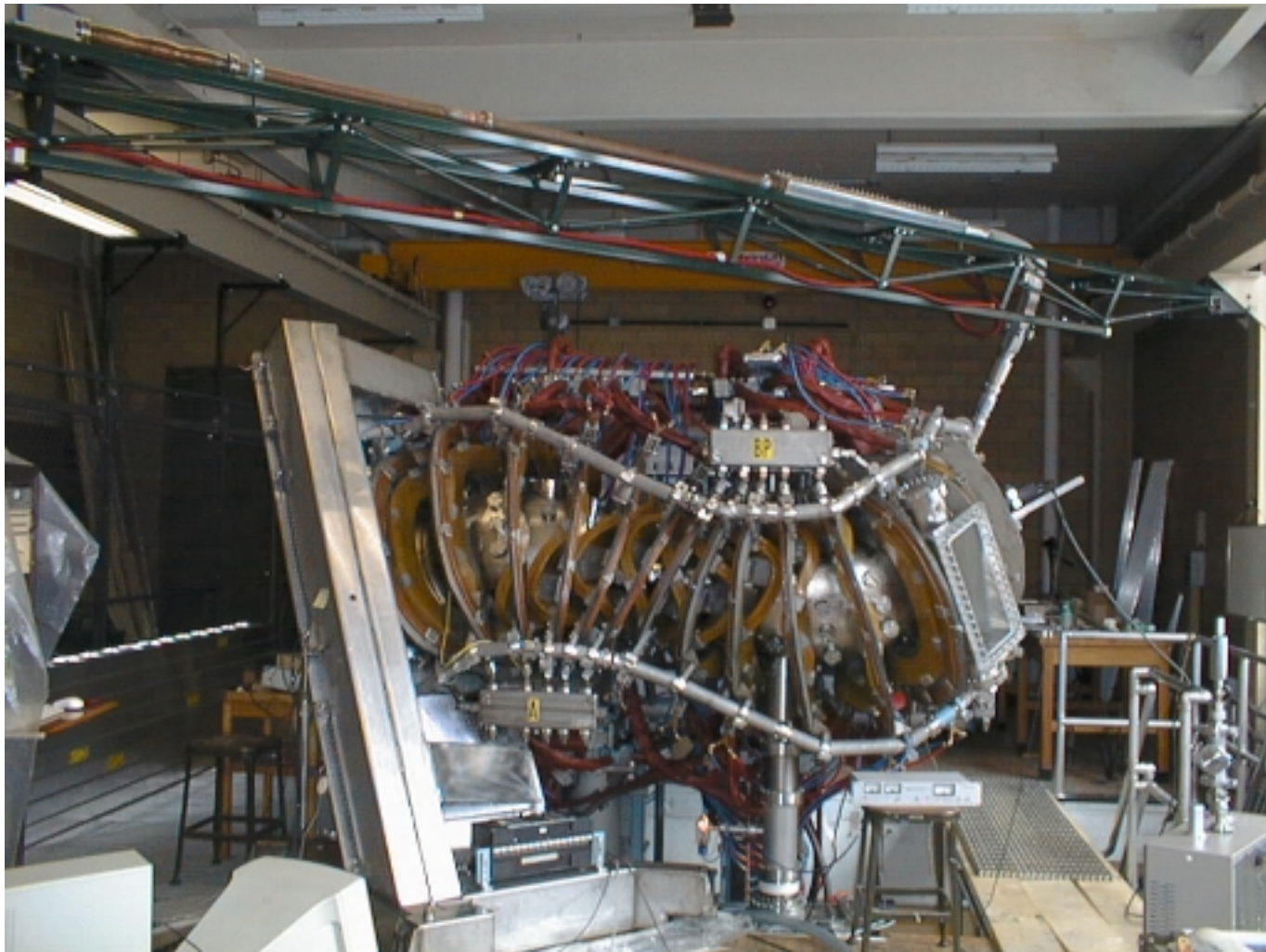

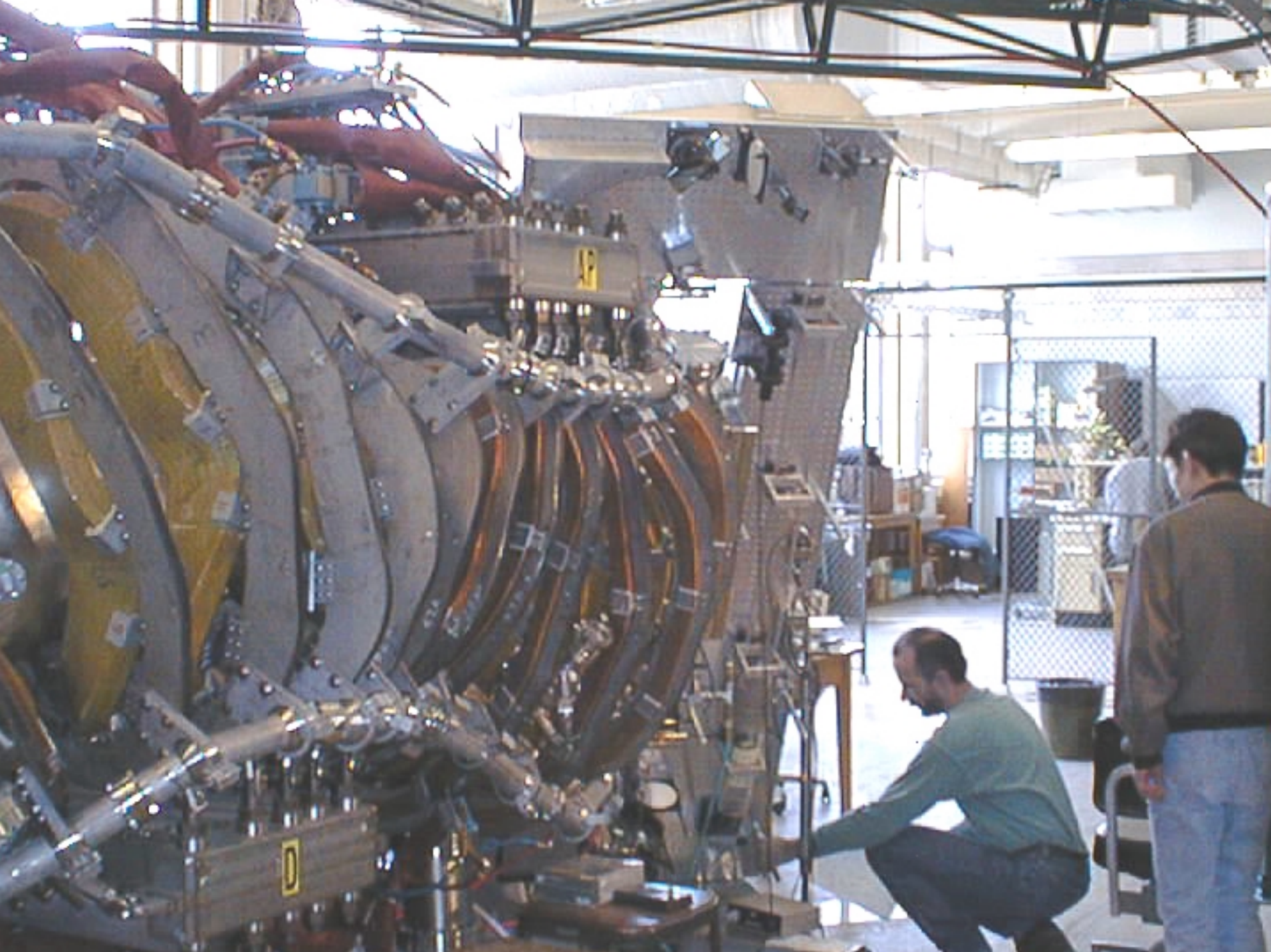

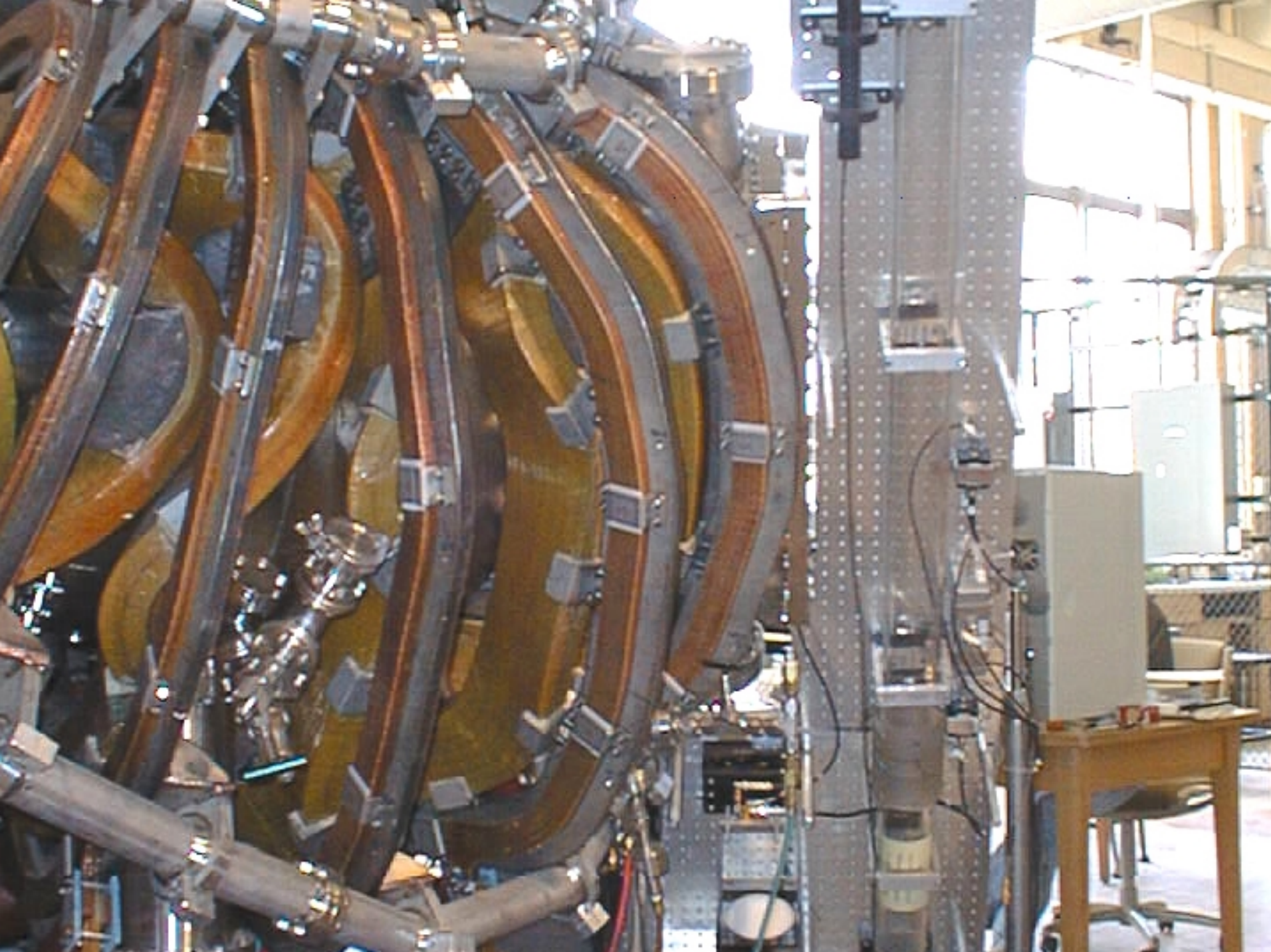

Analog Phase Comparator

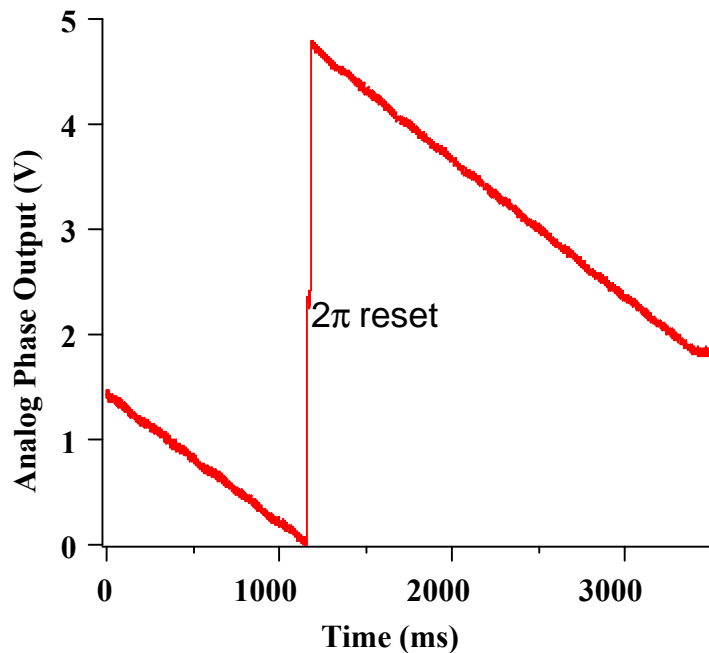

- Bandwidth < 10 kHz.
- rms phase noise 1.6 degree (24 mrad)
- $(\Delta n_e dl)_{\min} = 8 \times 10^{11} \text{ cm}^{-2}$
- Calibrated by moving mirror:
 $2\pi/4.73 \text{ V} = 76.11^\circ/\text{V}$

Digital Phase Comparator **DPC**

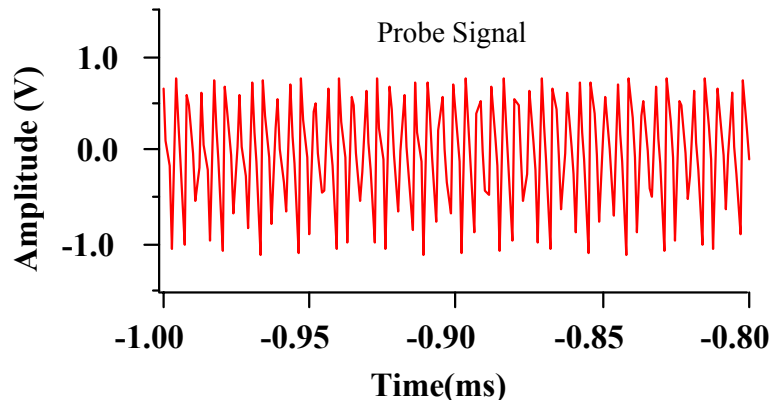
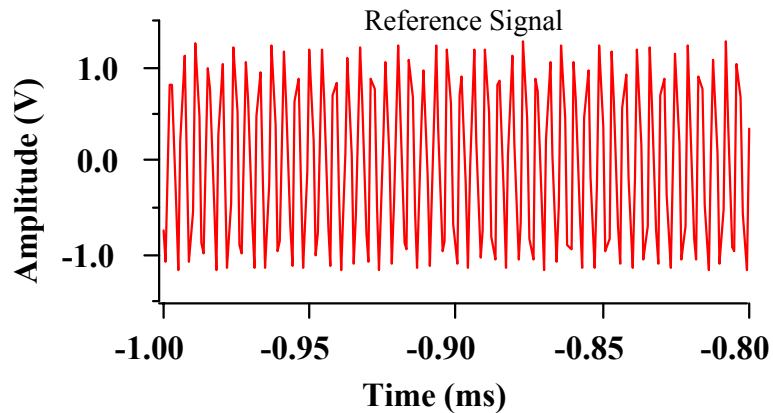

- **DPC reduces time response to $< 10 \mu\text{sec}$.**
- **775 kHz probe and reference signals are sampled at 1 MHz; aliased to 225 kHz.**
- **Phase difference can be computed directly by digital complex demodulation method.**

FFT Spectra Analysis

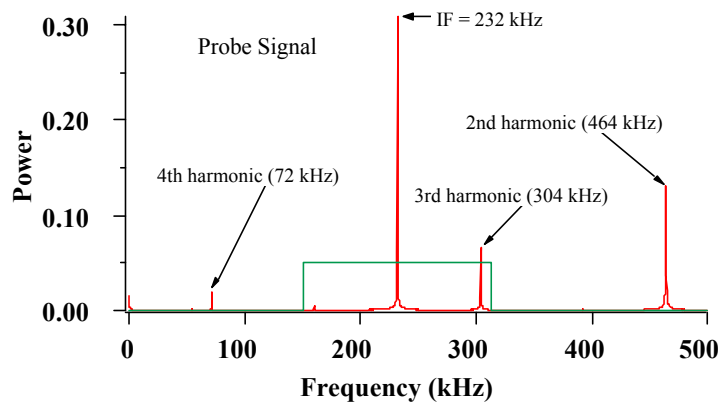
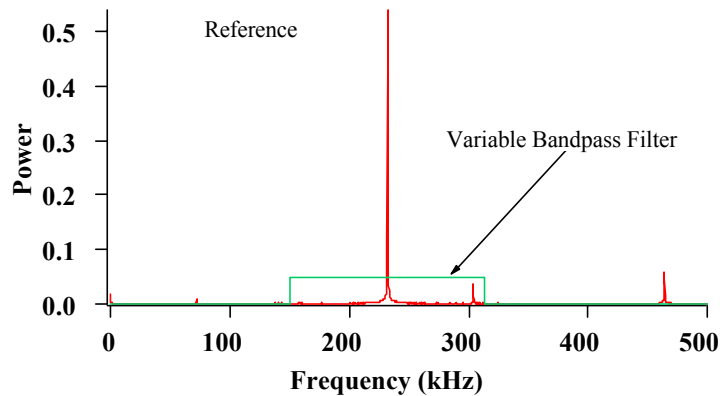

- **768 kHz IF sampled at 1 MHz, aliased to 232 kHz**
- **Sawtooth frequency modulation of source produces harmonics**
- **Unable to remove harmonic components completely with existing electronic filters ($70 \text{ kHz} < \text{passband} < 2 \text{ MHz}$ at 3 db points).**

DPC Phase Noise

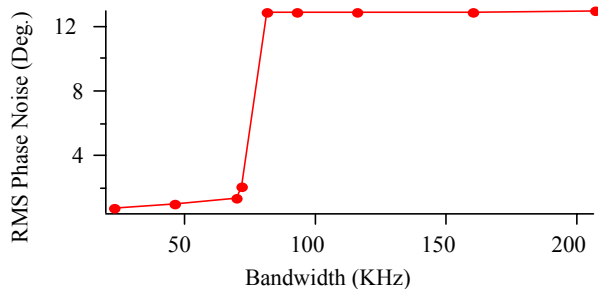
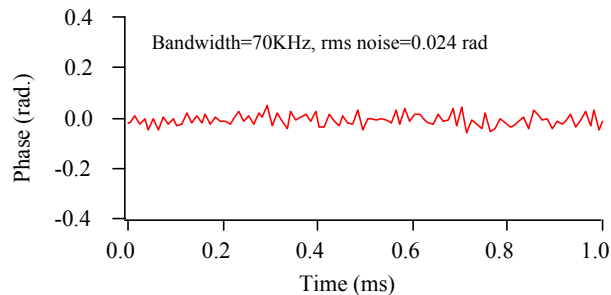
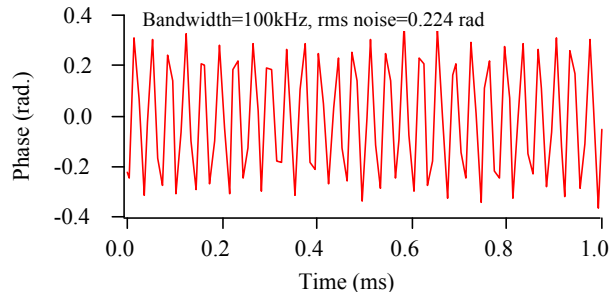

- **Including harmonic content in bandwidth of DPC causes phase oscillation**
- **Excluding harmonics from DPC bandwidth reduces rms phase noise to 24 mrad (same as analog PC with <10 kHz bw)**
- **100 kHz max. bandwidth with 1 MHz sampling**
- **250 kHz max. bandwidth with 2 MHz sampling**

Selecting IF and bandwidth

- Frequency Aliasing

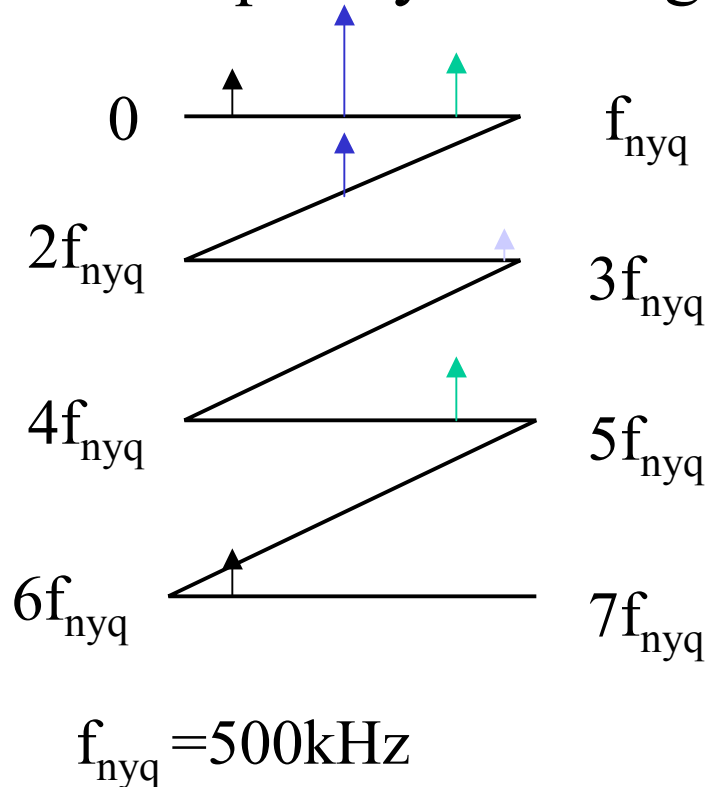

- **Selecting modulation frequency 775kHz will leave 2nd, 3rd and 4th harmonics out of 100kHz bandwidth.**
- **For sample rate 2MHz, selecting IF=750 kHz will give maximum bandwidth of 250 kHz without harmonic effect.**

Test of Inversion Approach

Magnetic Flux Surfaces and Chord Positions

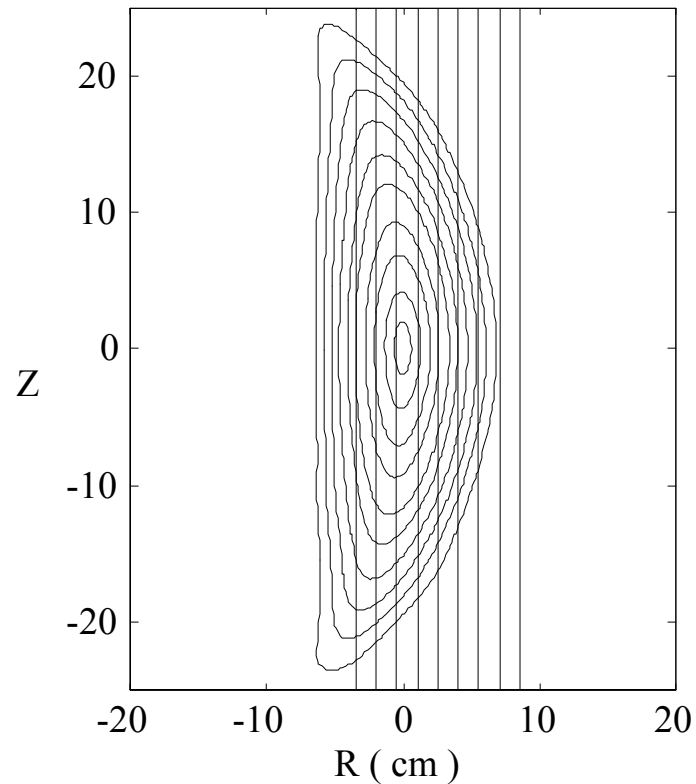

Density Profile Inversion

- **Method:** H. K. Park technique; asymmetric Abel inversion
 - flexible boundary conditions
 - non-circular geometry
 - plasma scrape-off-layer SOL estimate
- **Model:** spline fit to 9 channel line-density profile
 - no Shafranov Shift,
- **Path lengths:** calculated for ten vacuum flux surfaces,
- **SOL plasma contribution:** One viewing chord is outside the separatrix. This will provide information on the SOL contributions to other chords.

Peaked Density Profile: Parabolic

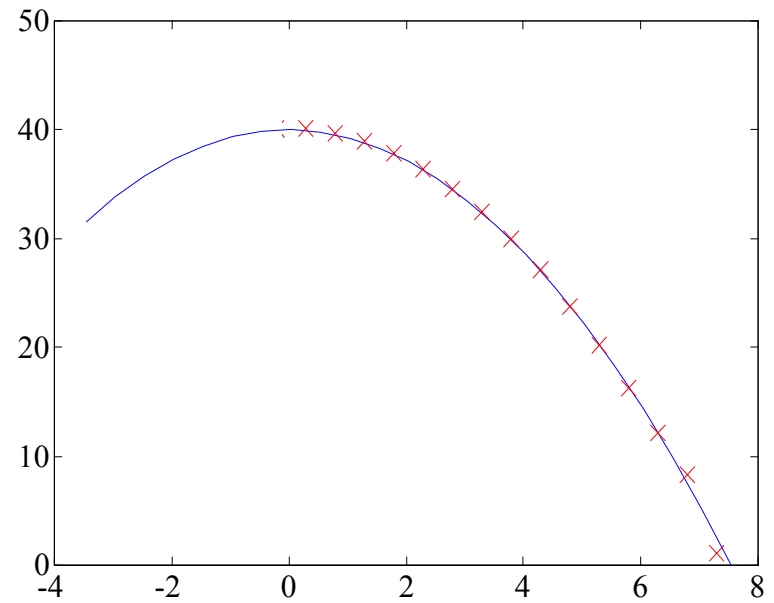
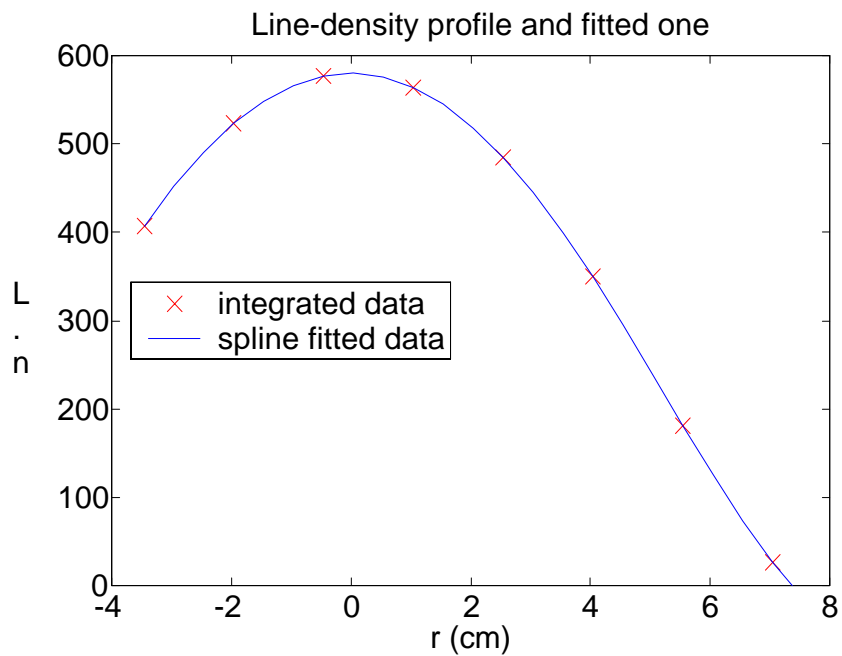

Hollow Density Profile

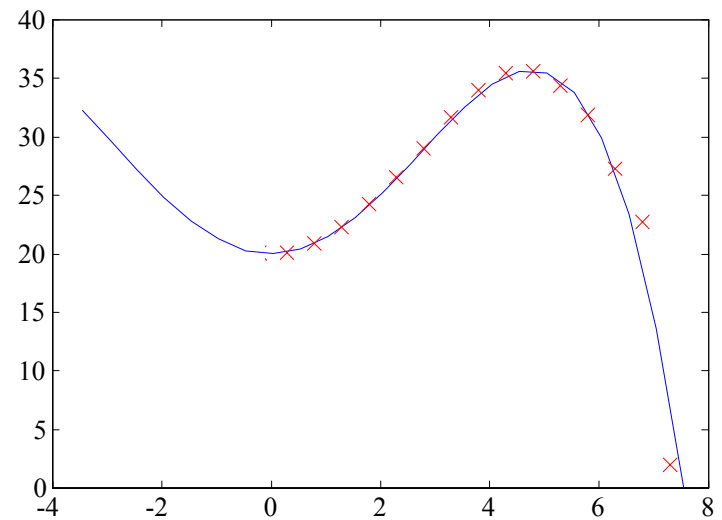
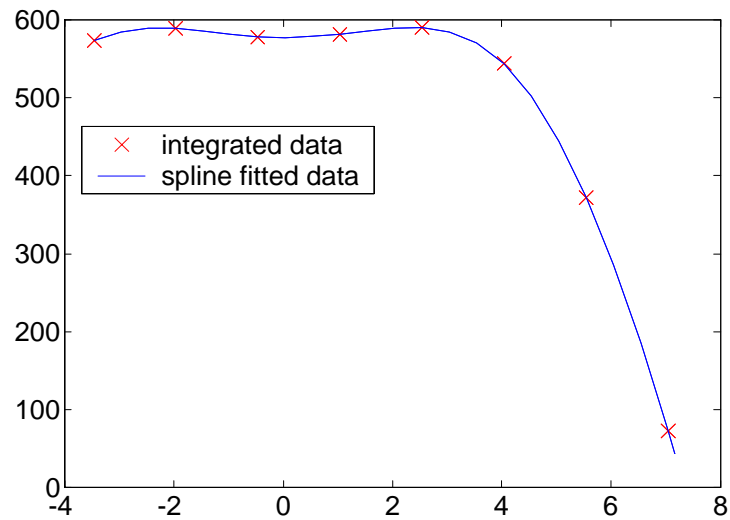

Conclusions

- High resolution FIR interferometer has been installed on the HSX stellarator
- Fast time response is achieved by digitizing signal waveforms and using complex demodulation techniques
- Density inversion approach is effective
- First experimental results anticipated in Summer, 2000