

# MAX

# Multi-ton Argon Xenon

## Katsushi Arisaka

*University of California, Los Angeles  
Department of Physics and Astronomy*

[arisaka@physics.ucla.edu](mailto:arisaka@physics.ucla.edu)

# MAX - Multi-ton Argon & Xenon

MAX Collaboration = XENON + DarkSide

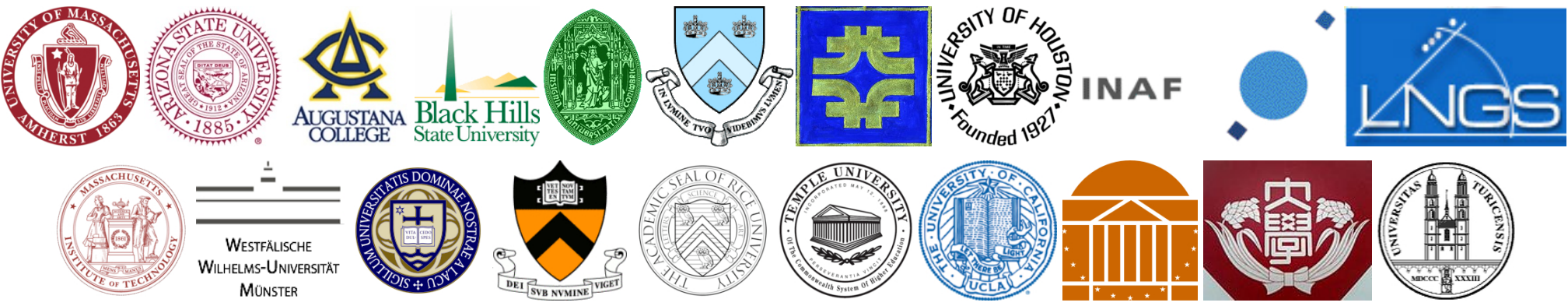

UMass Amherst, Arizona State University  
Augustana College, Black Hills State University  
Coimbra University, Columbia University  
Fermilab, University of Houston, INAF, LNGS  
MIT, University of Münster, University of Notre Dame  
Princeton University, Rice University, Temple University  
UCLA, University of Virginia, Waseda University  
University of Zürich

# G2 and G3 facilities at DUSEL

defined by PASAG

	G2	G3
Sensitivity	$< 10^{-46} \text{ cm}^2$	$< 10^{-47} \text{ cm}^2$
Target Mass	~ 1 Ton	~ 10 Ton
Cost	\$15M - \$20M	~ \$50M

# 90% CL Limits of SI Cross Section

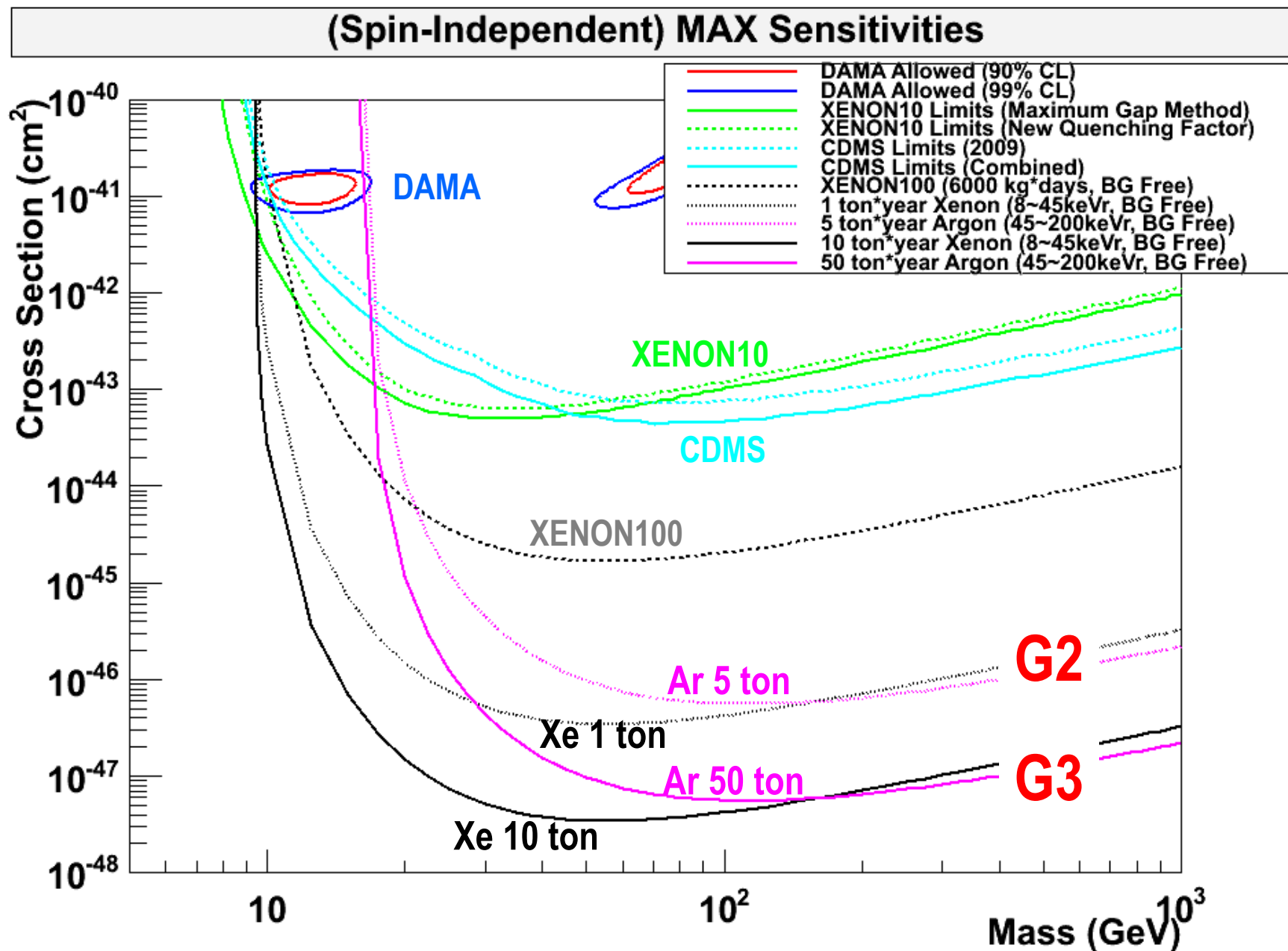

# MAX G2 Detector

**Xe**

**2 ton (1 ton)  
= XENON1T**

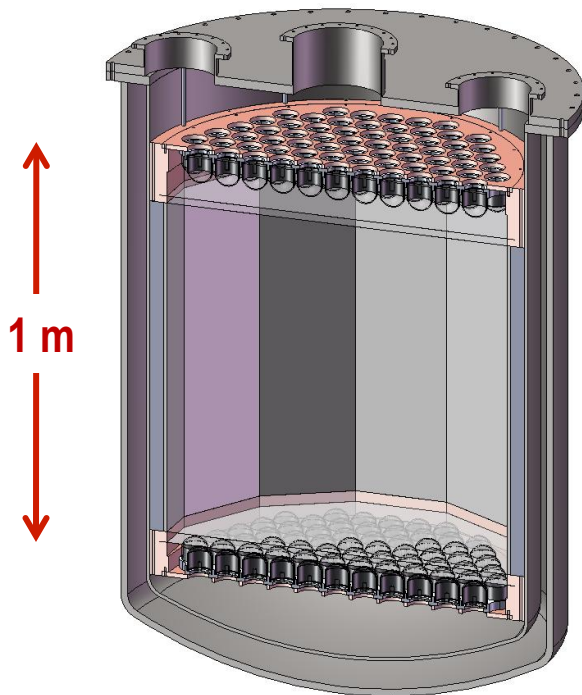

3" QUPID x 121 (Top)  
3" QUPID x 121 (Bottom)

**$^{40}\text{Ar}$   
10 ton  
(5 ton)**

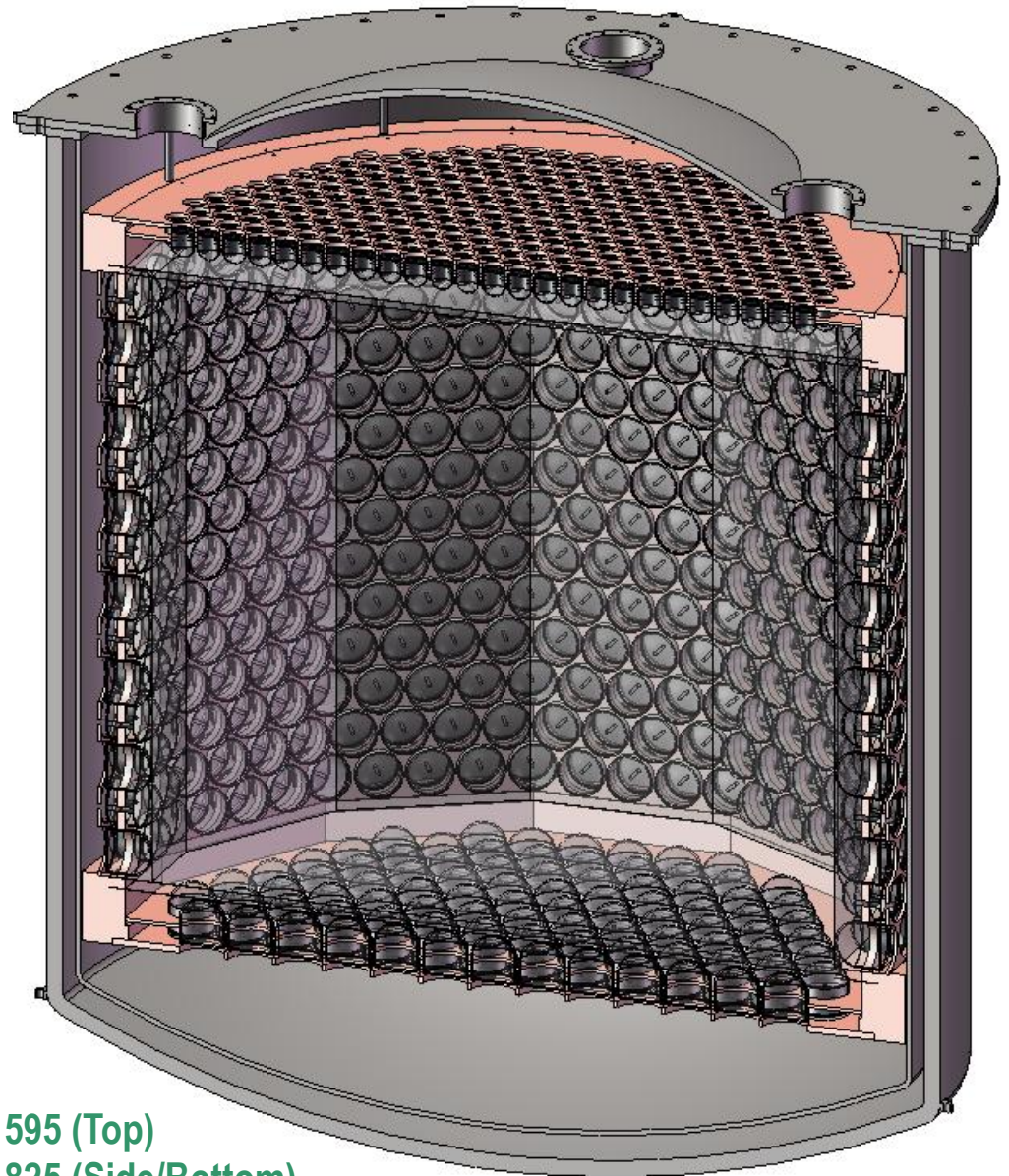

3" QUPID x 595 (Top)  
6" QUPID x 825 (Side/Bottom)

# MAX G3 Detector

**Xe**  
20 ton  
(10 ton)

**$^{40}\text{Ar}$**   
70 ton  
(50 ton)

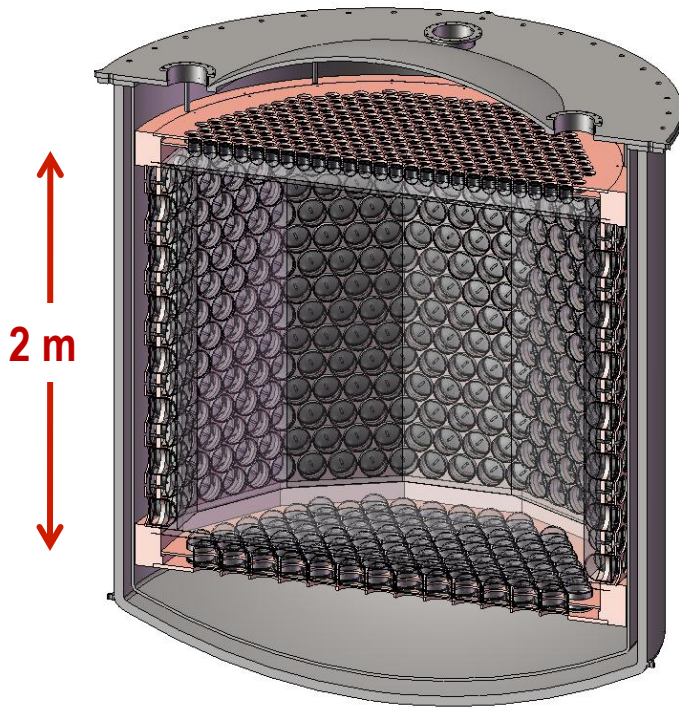

3" QUPID x 595 (Top)  
6" QUPID x 825 (Side/Bottom)

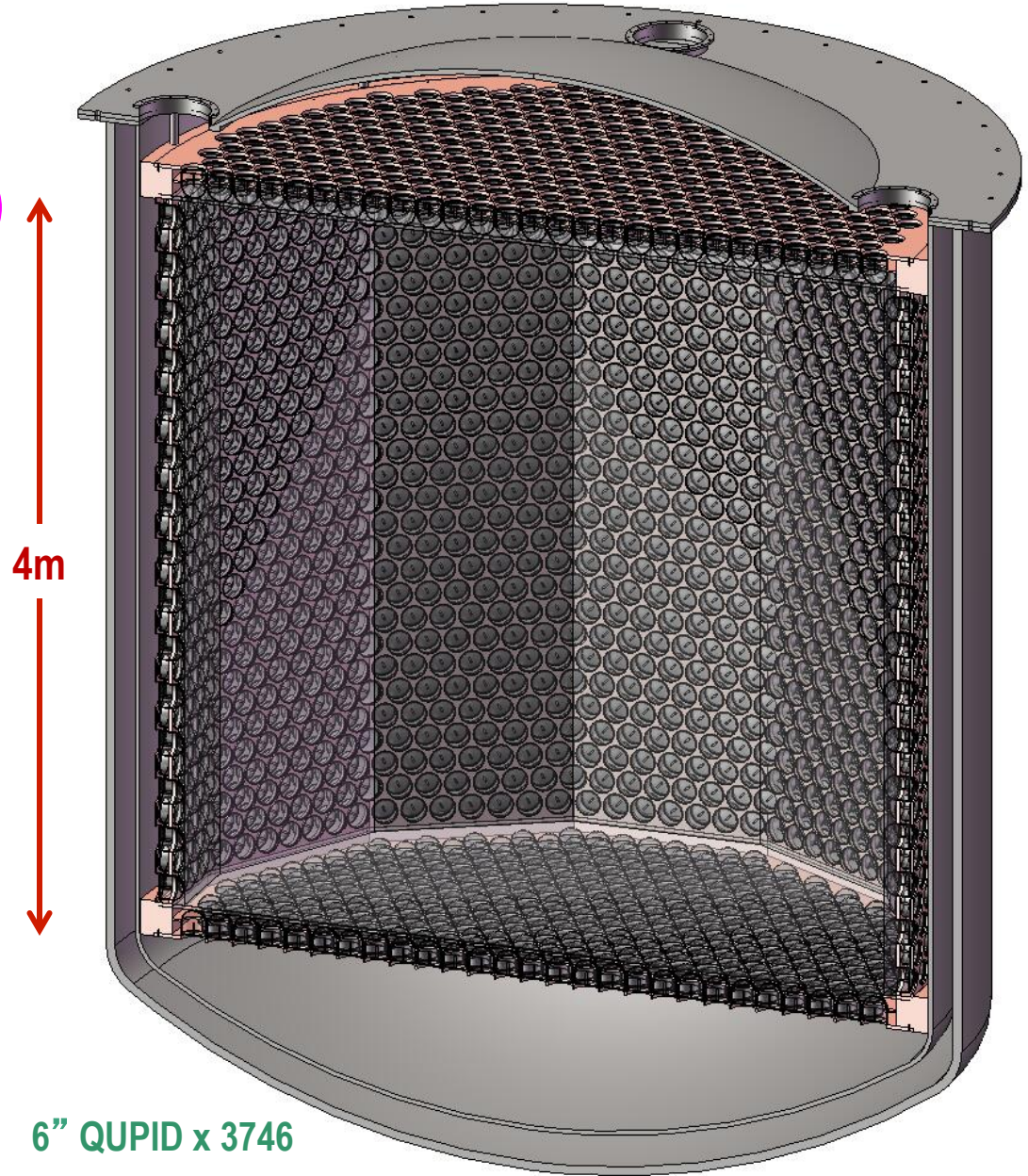

6" QUPID x 3746

# MAX Shielding Structure

Xe 20 ton (10 ton)

$^{40}\text{Ar}$  70 ton (50 ton)

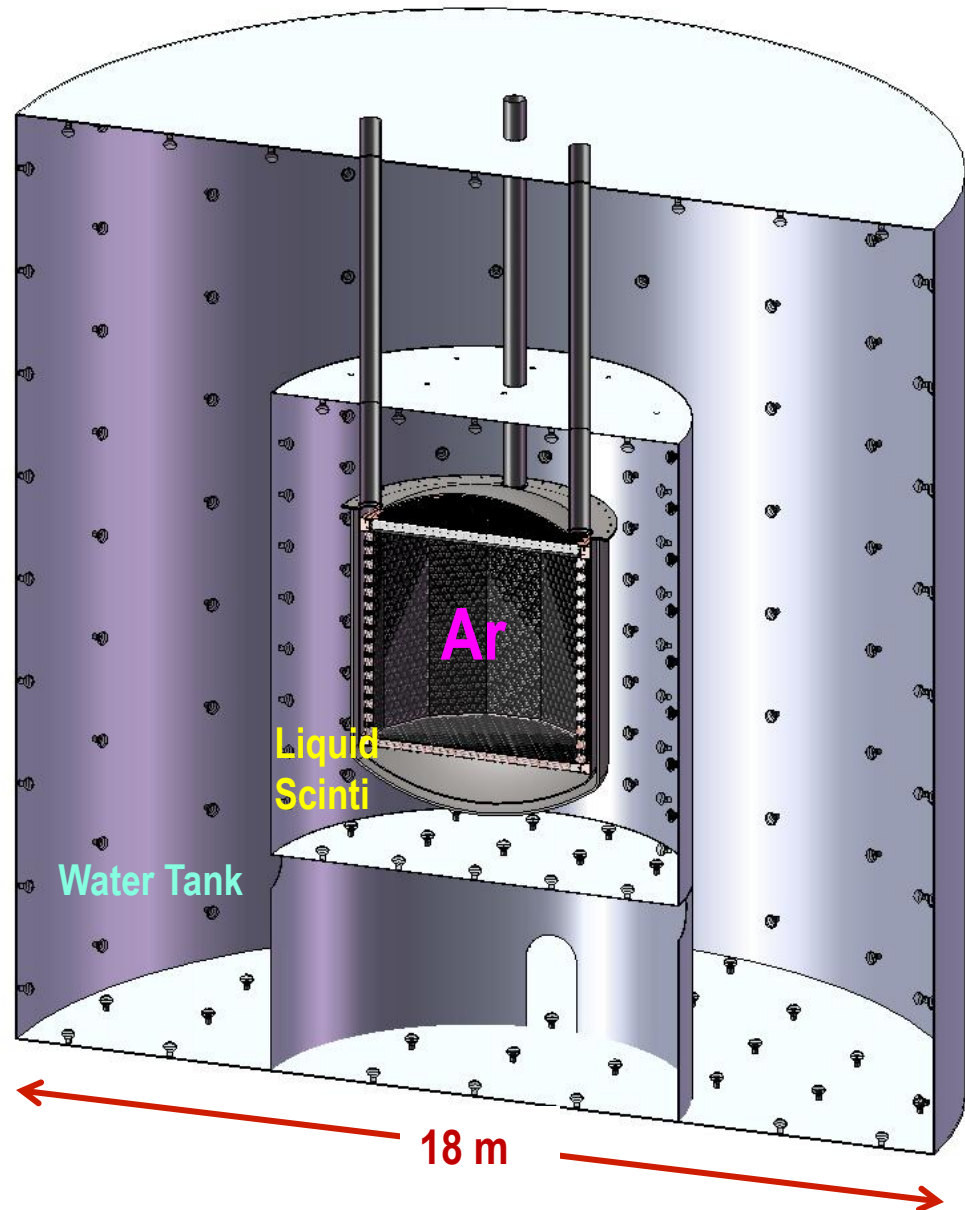
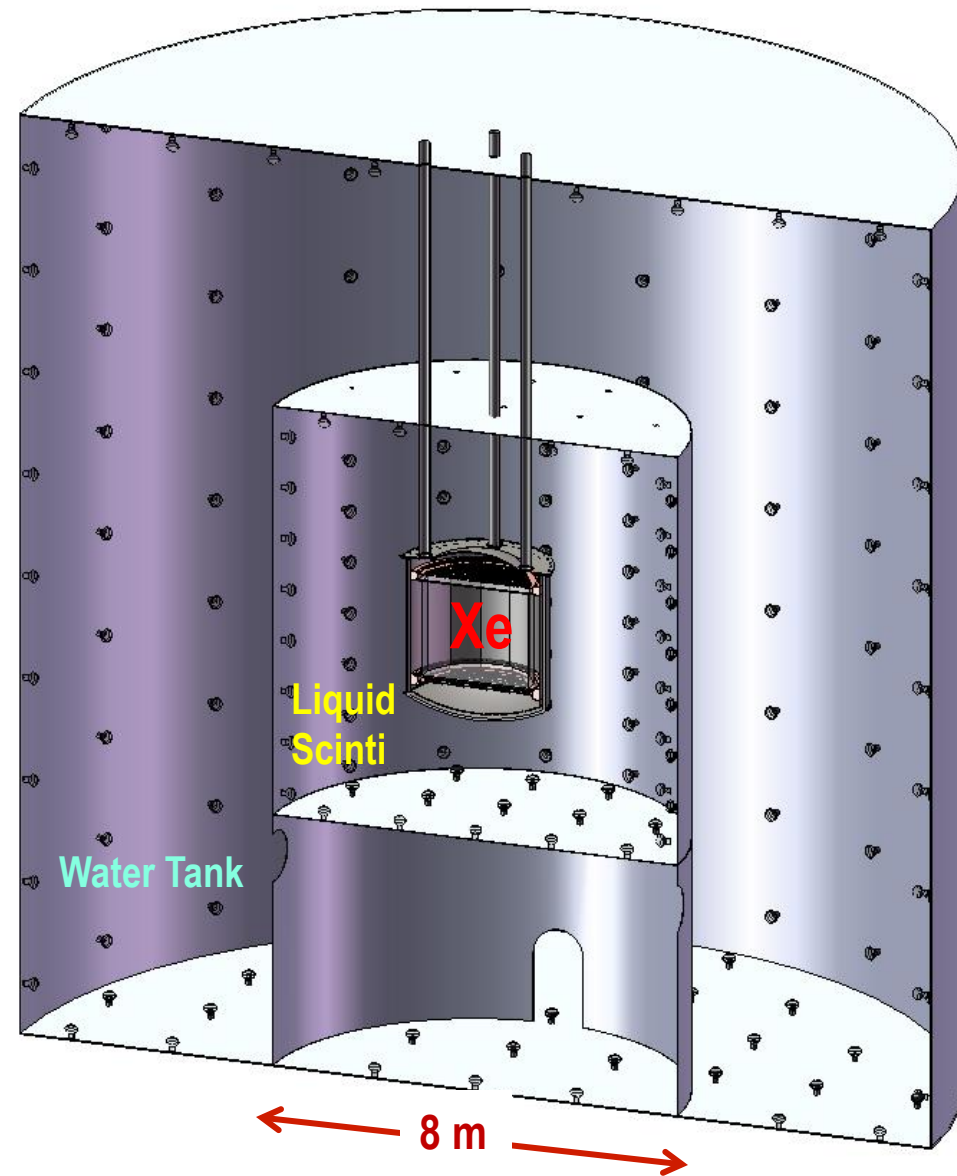

# MAX Facility at DUSEL

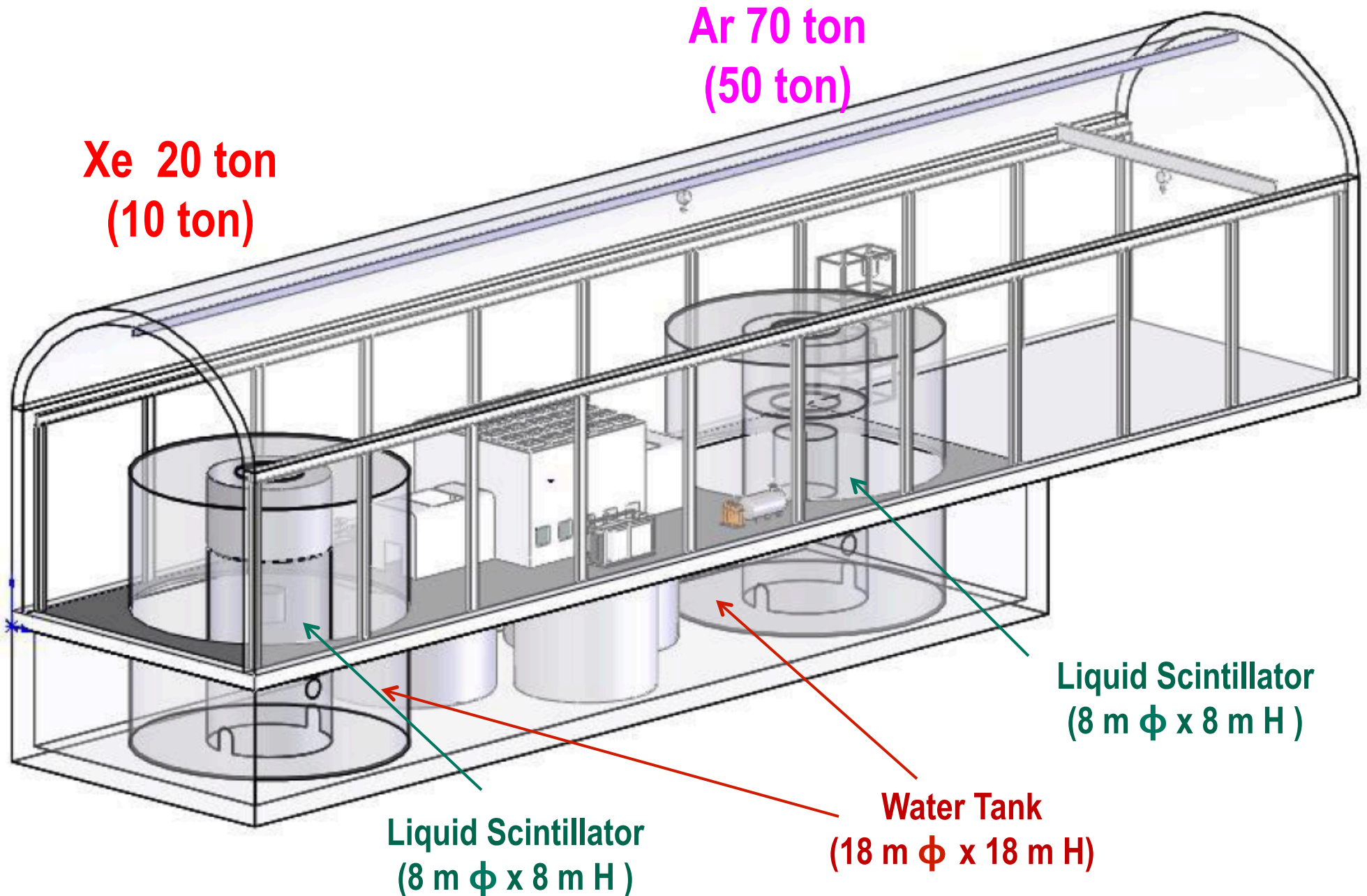

# (SI) WIMP Energy Spectrum for Various Targets (Cross Section = $10^{-45}\text{cm}^2$ )

(SI) WIMP Recoil Energy Spectrum ( $M = 100\text{GeV}$ ,  $\sigma = 10^{-45}\text{cm}^2$ )

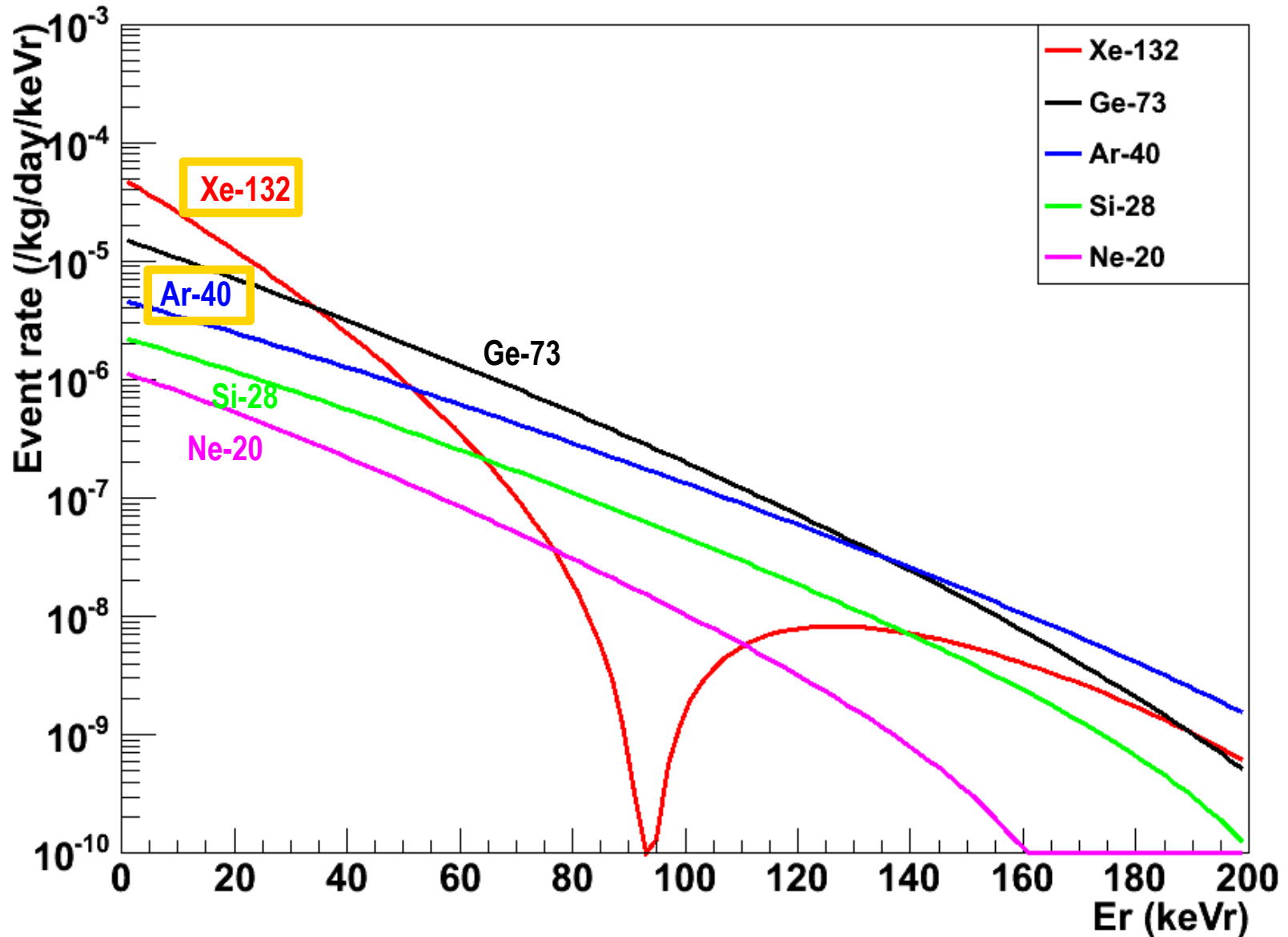

# (SI) WIMP Energy Spectrum for LXe (Cross Section = $10^{-45} \text{cm}^2$ )

(SI) WIMP Recoil Energy Spectrum for LXe ( $\sigma = 10^{-45} \text{cm}^2$ )

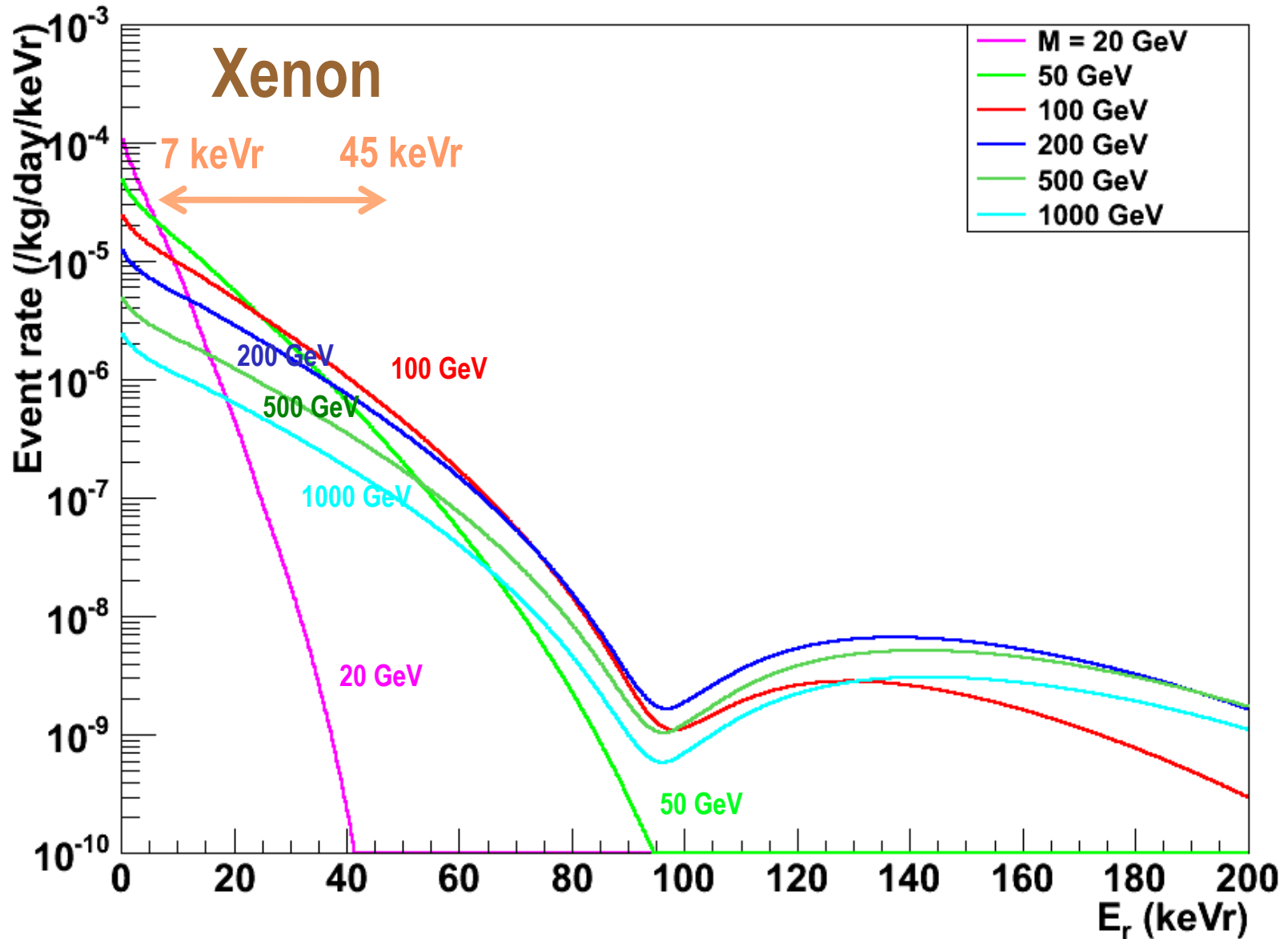

# (SI) WIMP Energy Spectrum for LXe (Cross Section = $10^{-45} \text{cm}^2$ )

(SI) WIMP Recoil Energy Spectrum for LXe ( $\sigma = 10^{-45} \text{cm}^2$ )

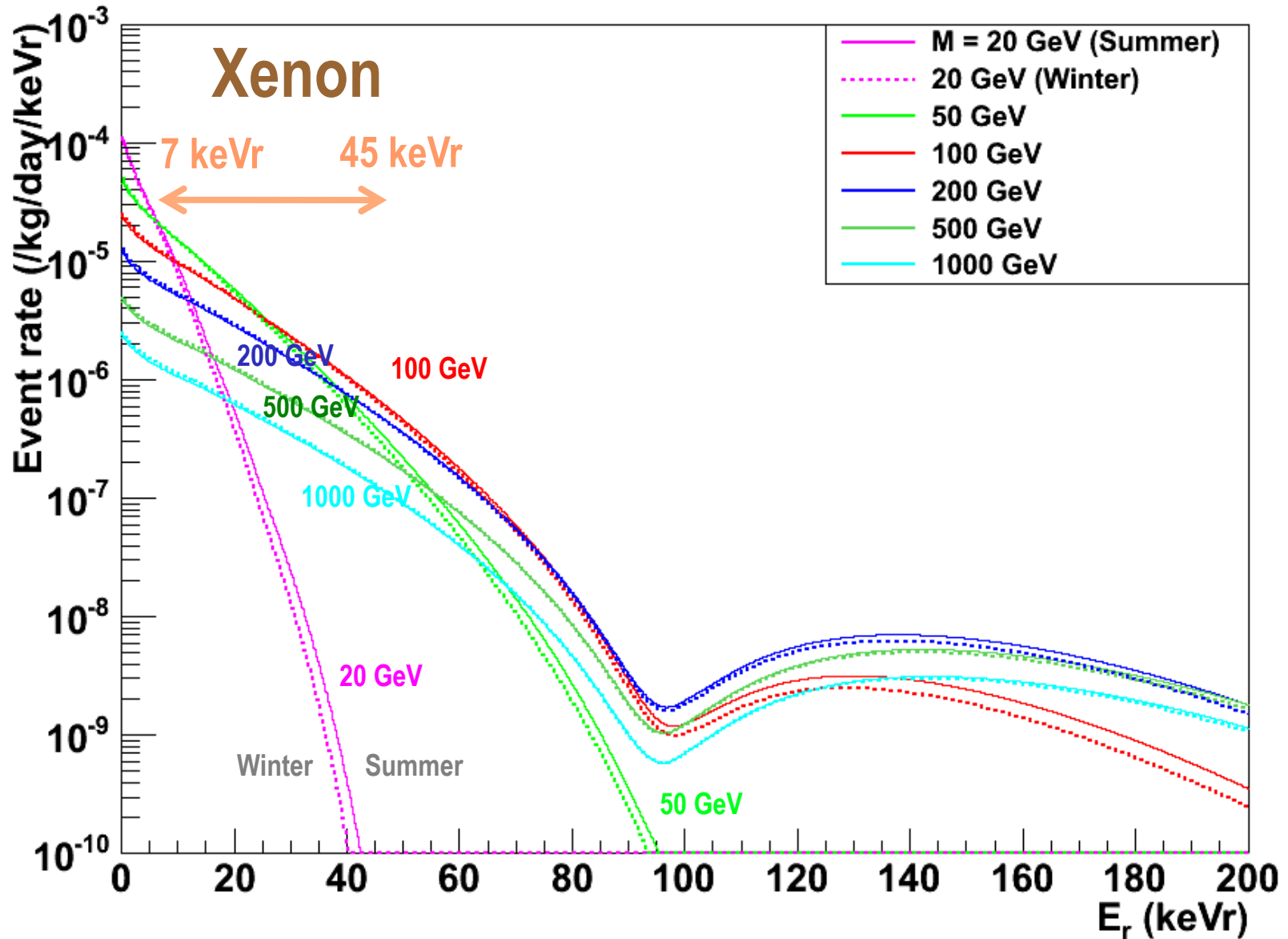

# (SI) WIMP Energy Spectrum for LAr (Cross Section = $10^{-45} \text{cm}^2$ )

(SI) WIMP Recoil Energy Spectrum for LAr ( $\sigma = 10^{-45} \text{cm}^2$ )

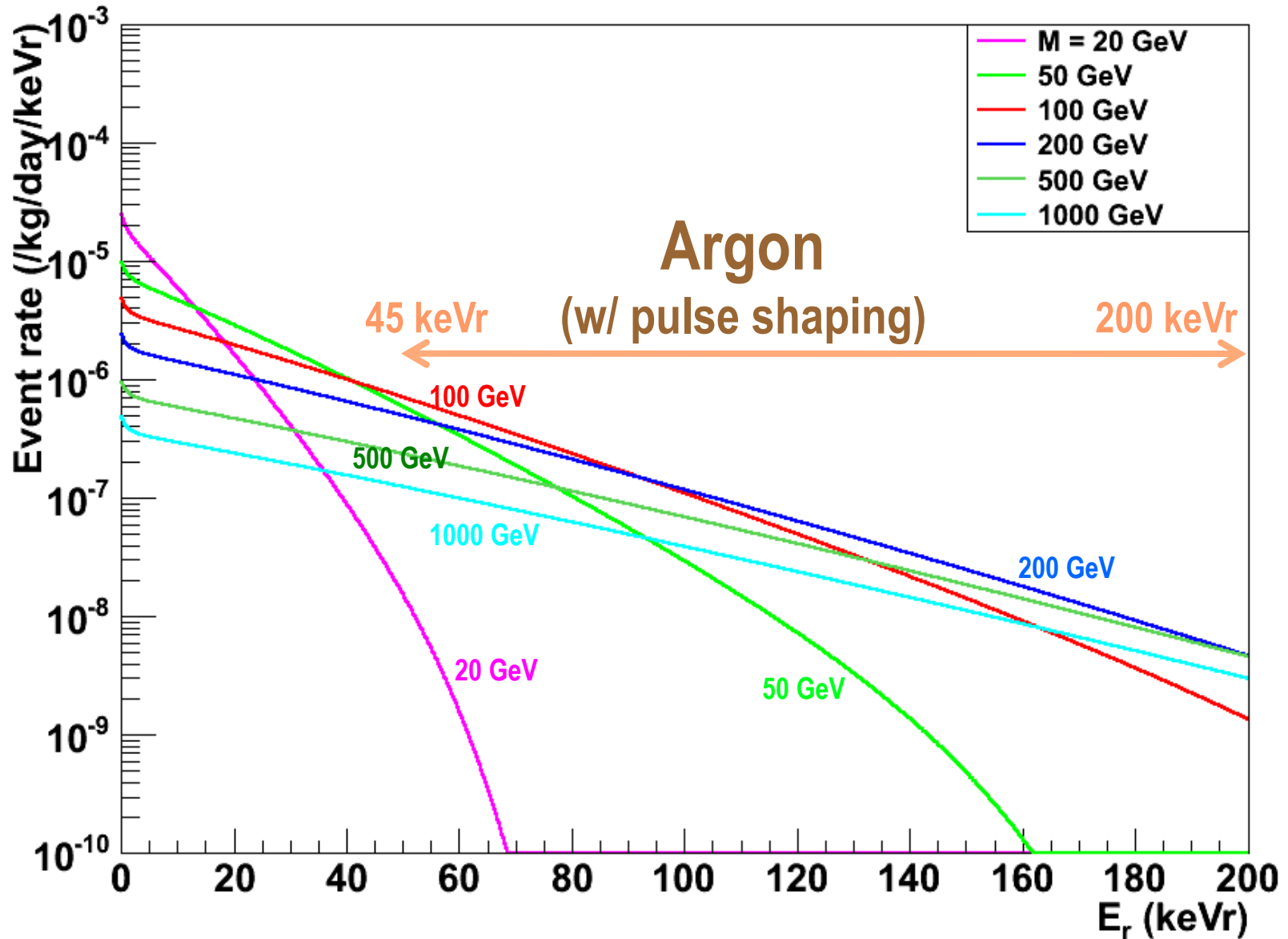

# (SI) WIMP Energy Spectrum for LAr (Cross Section = $10^{-45} \text{cm}^2$ )

(SI) WIMP Recoil Energy Spectrum for LAr ( $\sigma = 10^{-45} \text{cm}^2$ )

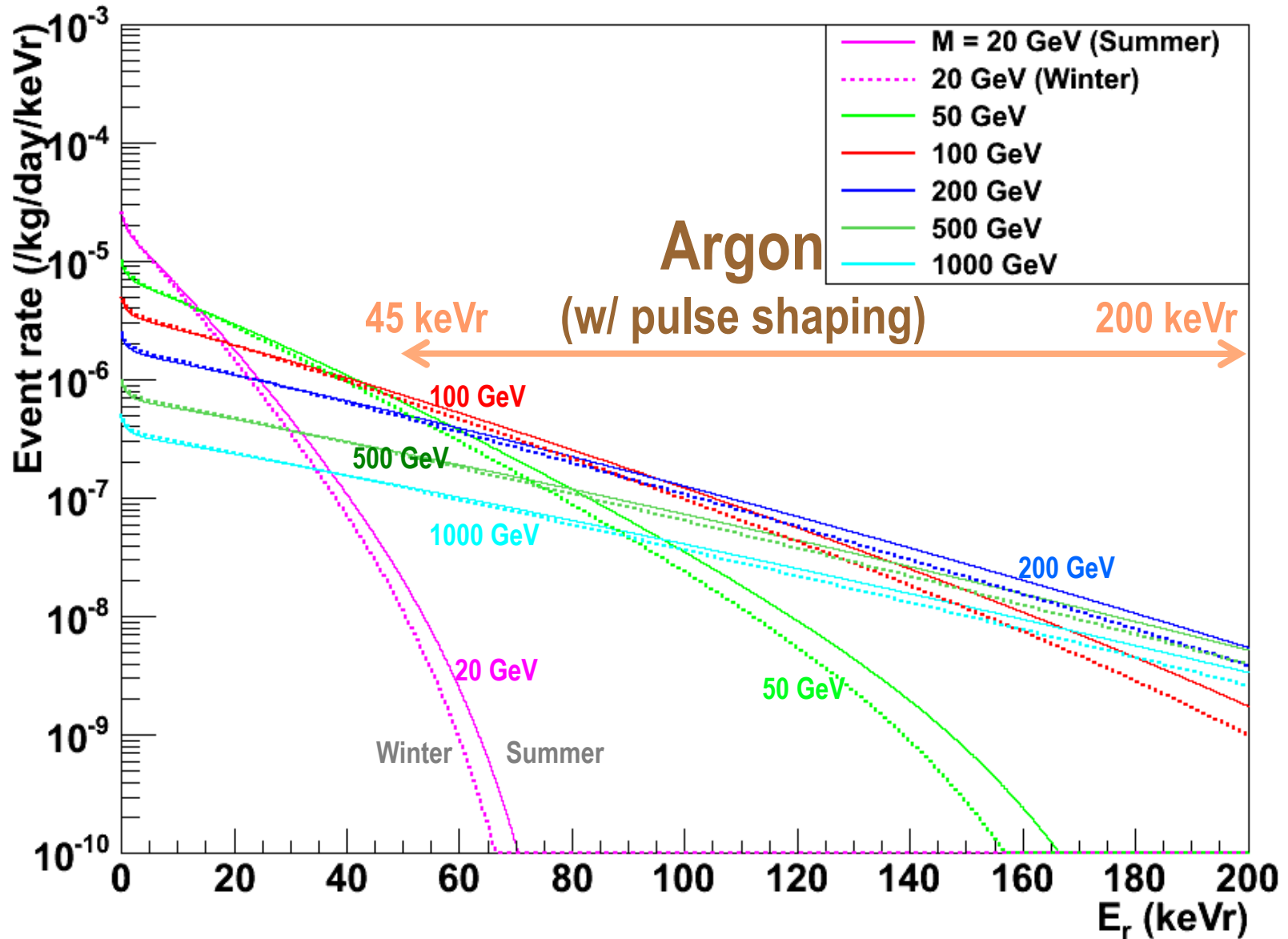

# 1- $\sigma$ Error of WIMP Mass vs SI Cross Section (10 ton\*year Xe and 50 ton\*year Ar)

1- $\sigma$  Error of WIMP Mass and SI Cross Section

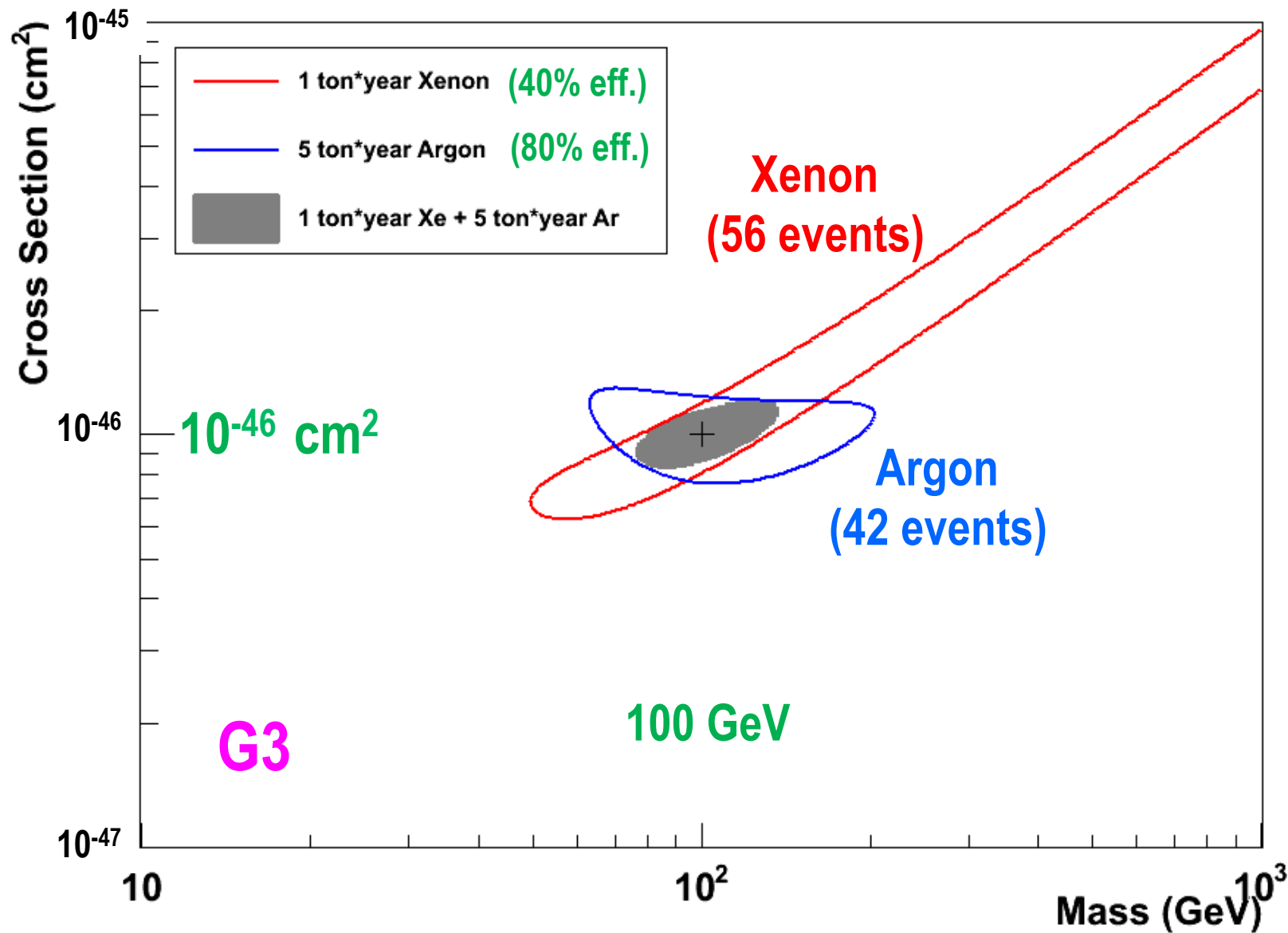

# 1- $\sigma$ Error of WIMP Mass vs SI Cross Section (10 ton\*year Xe and 50 ton\*year Ar)

1- $\sigma$  Error of WIMP Mass and SI Cross Section

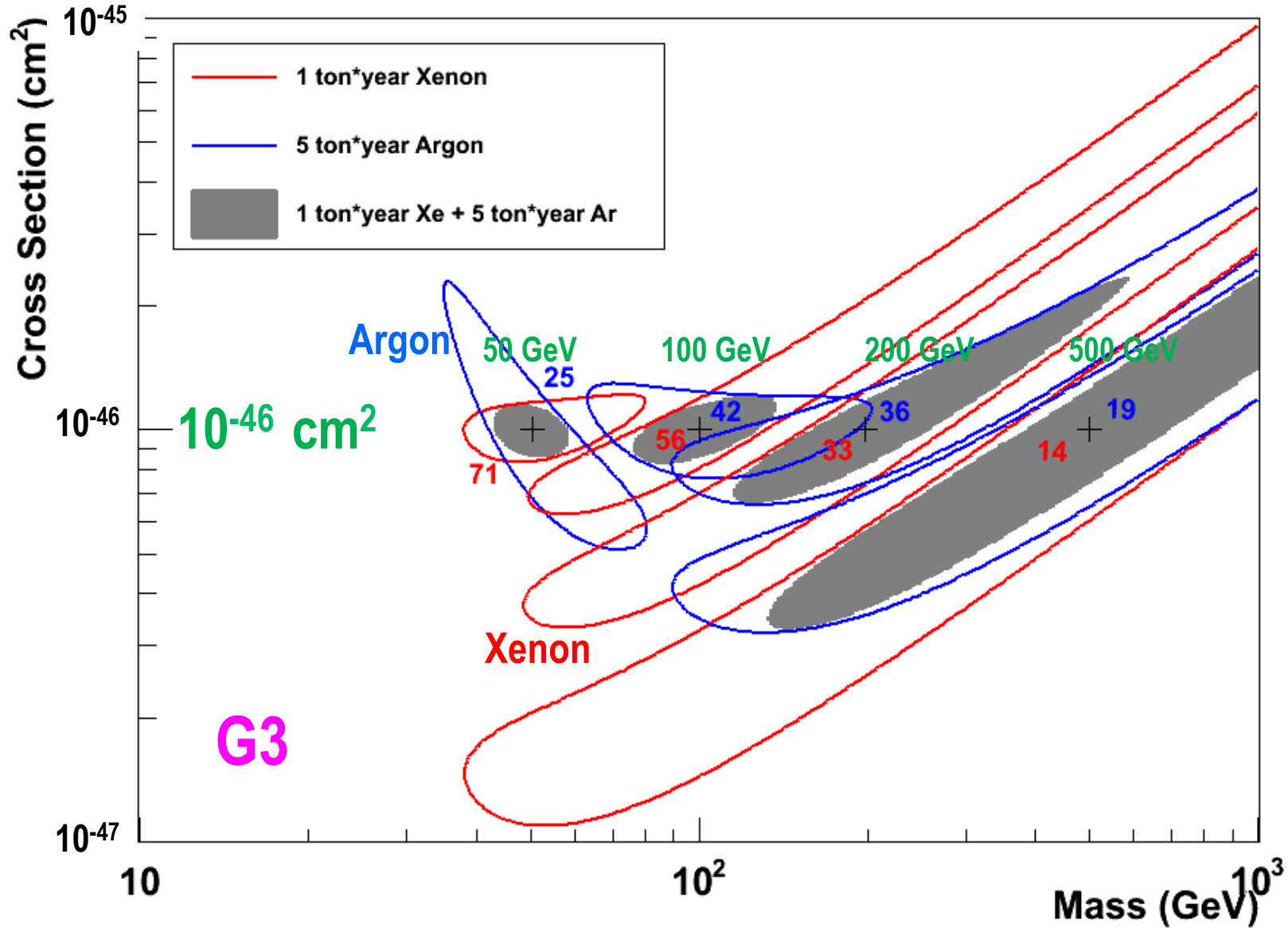

# 1- $\sigma$ Error of WIMP Mass vs SI Cross Section (10 ton\*year Xe and 50 ton\*year Ar)

1- $\sigma$  Error of WIMP Mass and SI Cross Section

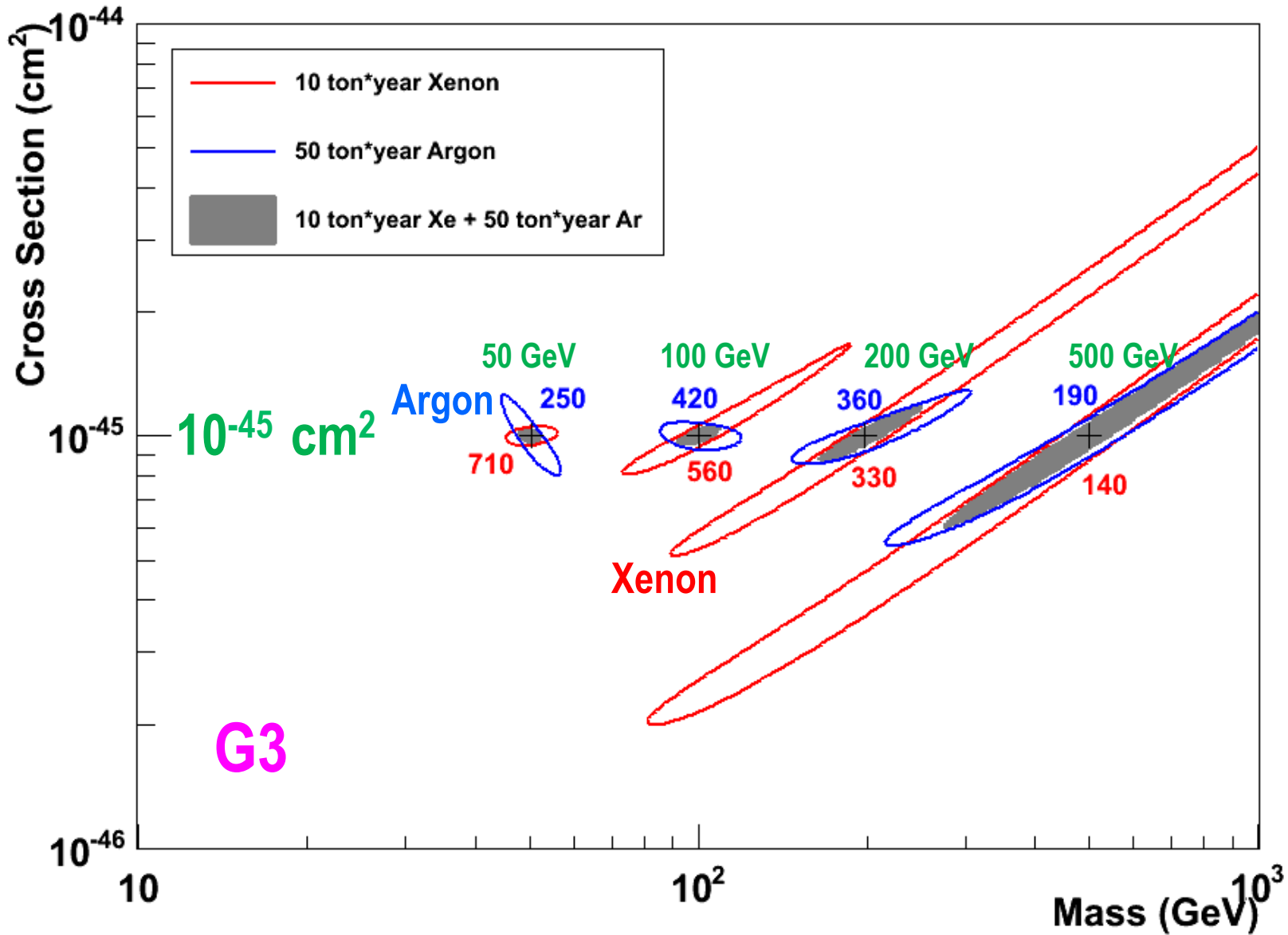

# $\pm 1 \sigma$ Error of Annual Modulation Amplitude vs WIMP Mass (10 ton\*year Xe and 50 ton\*year Ar, Cross Section = $10^{-45} \text{cm}^2$ )

1-Sigma Error of Annual Modulation Amplitude vs WIMP Mass ( $\sigma = 1\text{E-}45\text{cm}^2$ )

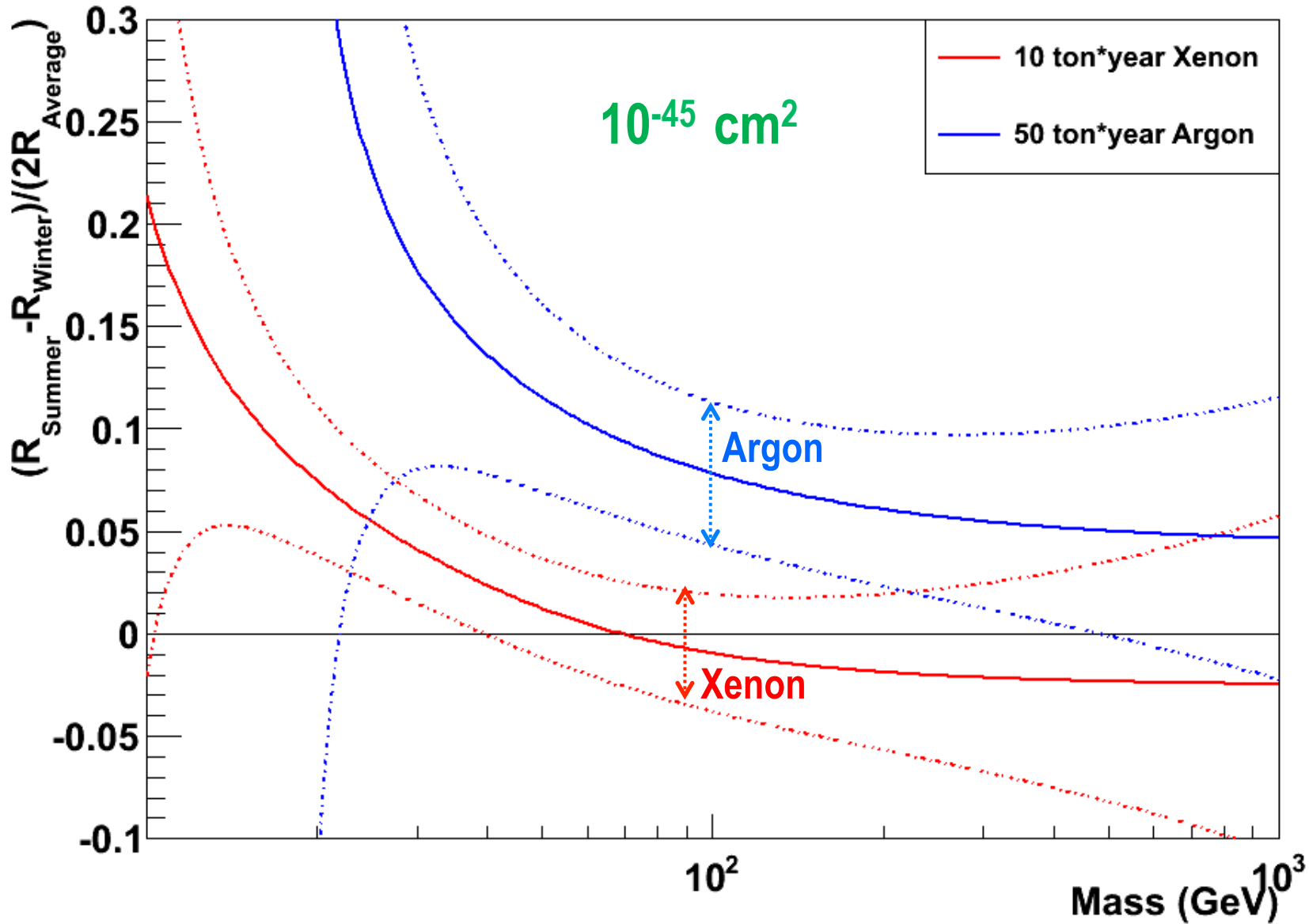

# $\pm 1\sigma$ Error of Annual Modulation Amplitude vs WIMP Mass (10 ton\*year Xe and 50 ton\*year Ar, Cross Section = $10^{-44}\text{cm}^2$ )

1-Sigma Error of Annual Modulation Amplitude vs WIMP Mass ( $\sigma = 1\text{E-}44\text{cm}^2$ )

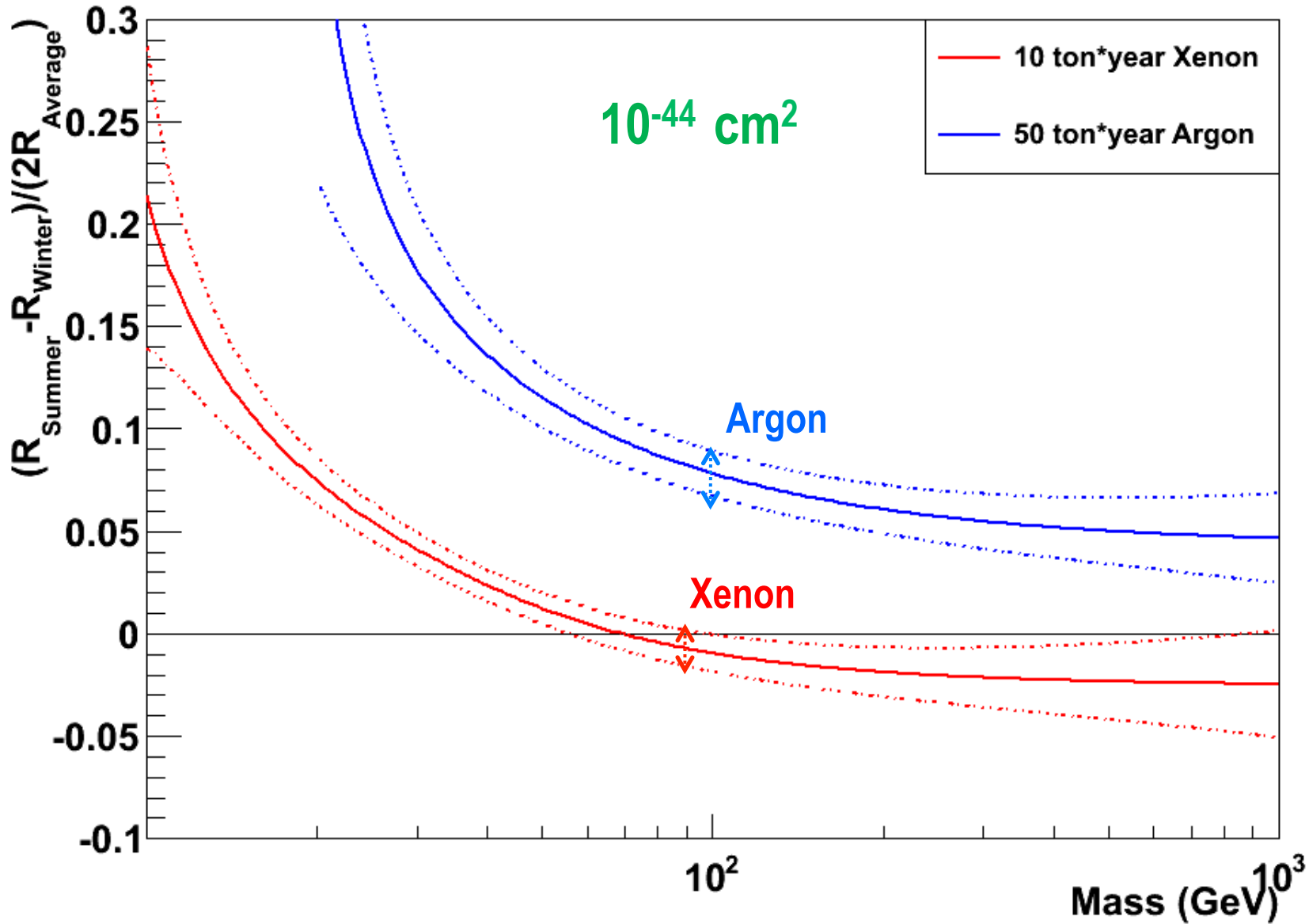

# Xe 10 ton (Ar 5 ton) Detector Structure

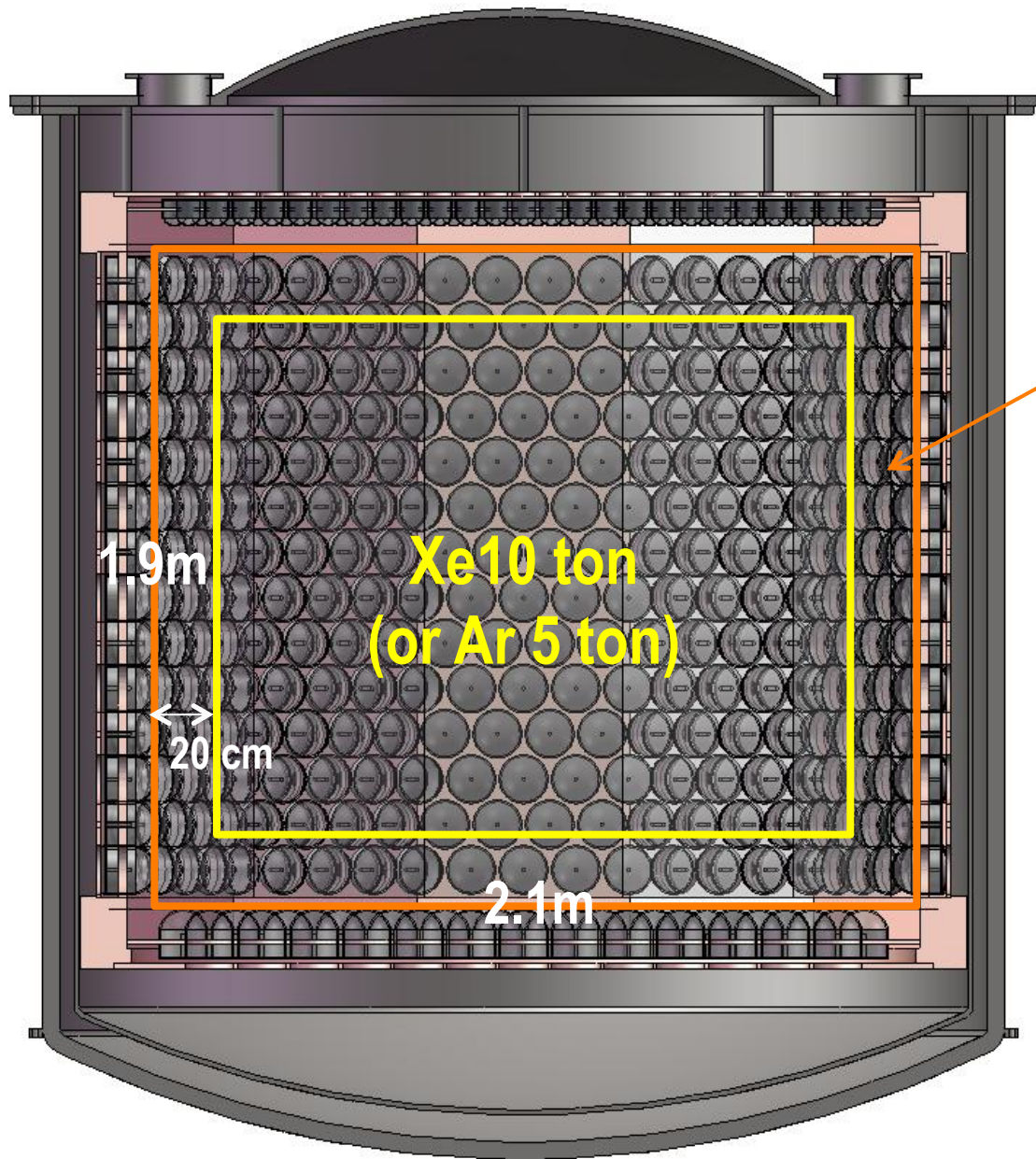

Xe 20 ton  
(or Ar 10 ton)

Top: 3" QUPID x 595  
Side: 6" QUPID x 672  
Bottom: 6" QUPID x 163

# Xe 10 ton (Ar 5 ton) Top-Corner

3" QUPID

Mesh Wire

Gas Xe (Ar)

Liquid Xe (Ar)

6" QUPID

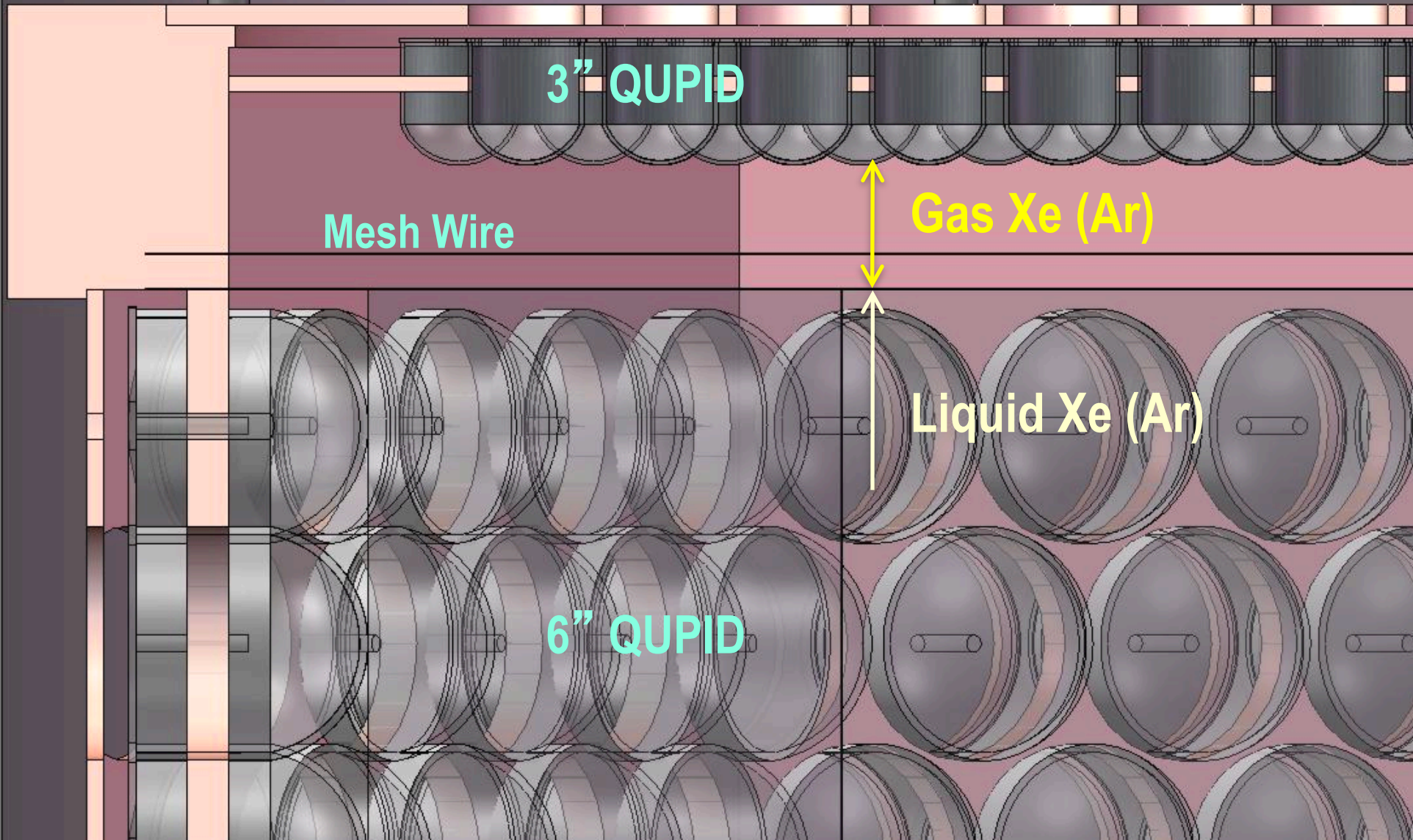

# QUPID (QUartz Photon Intensifying Detector)

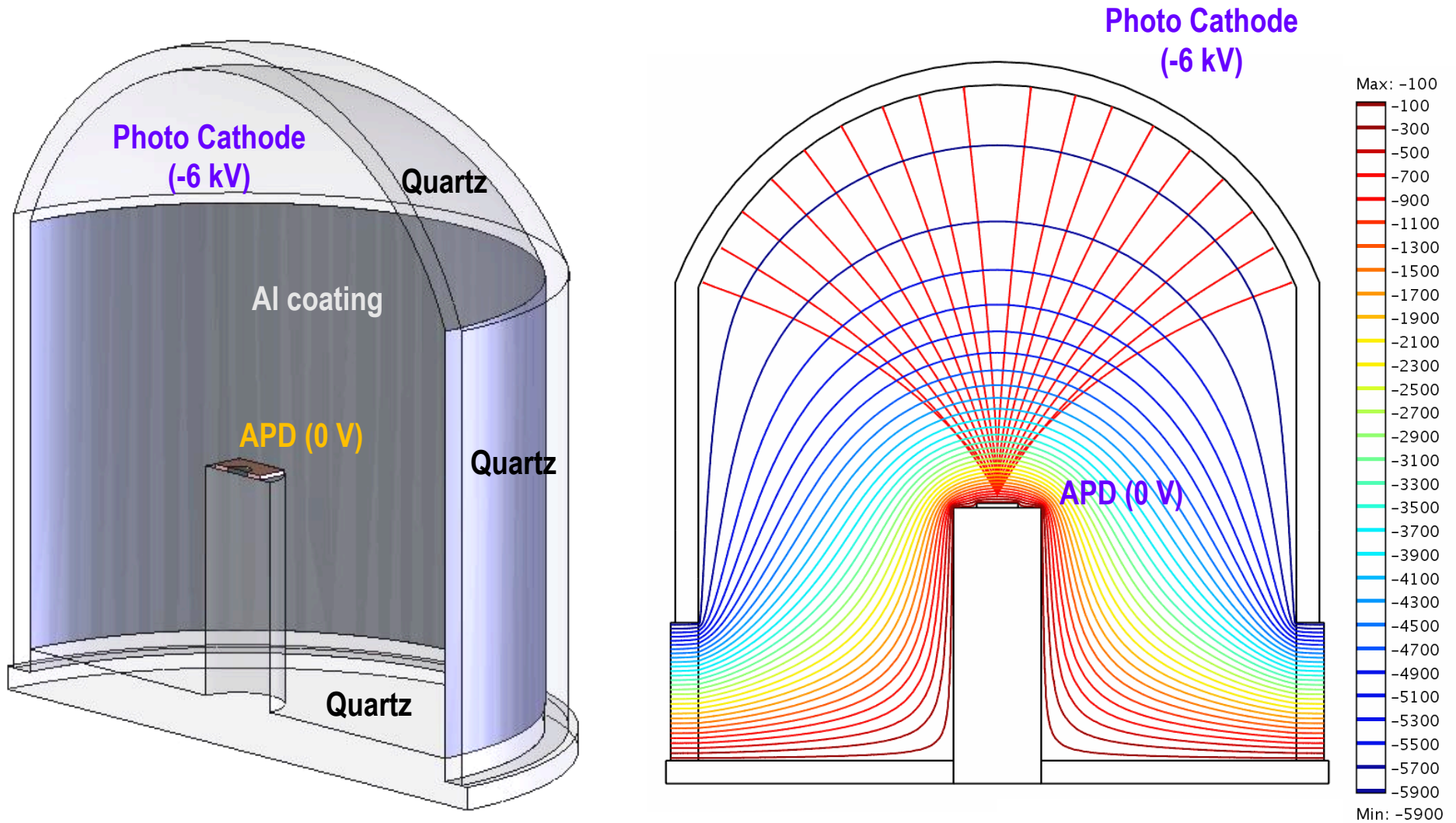

US Patent (No. 5374826) pending.

# Comparison of Low-radioactive Photon Detectors from Hamamatsu

R8520  
1 inch

R8778  
2 inch

QUPID  
3 inch

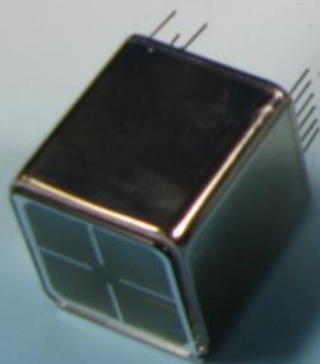

XENON10  
XENON100

LUX  
(XMASS)

XENON1Ton  
DarkSide50  
MAX

# New 3" QUPID (Production Version)



# Spectrum of QUPIDs and Background (4 QUPIDs x 1 month data)

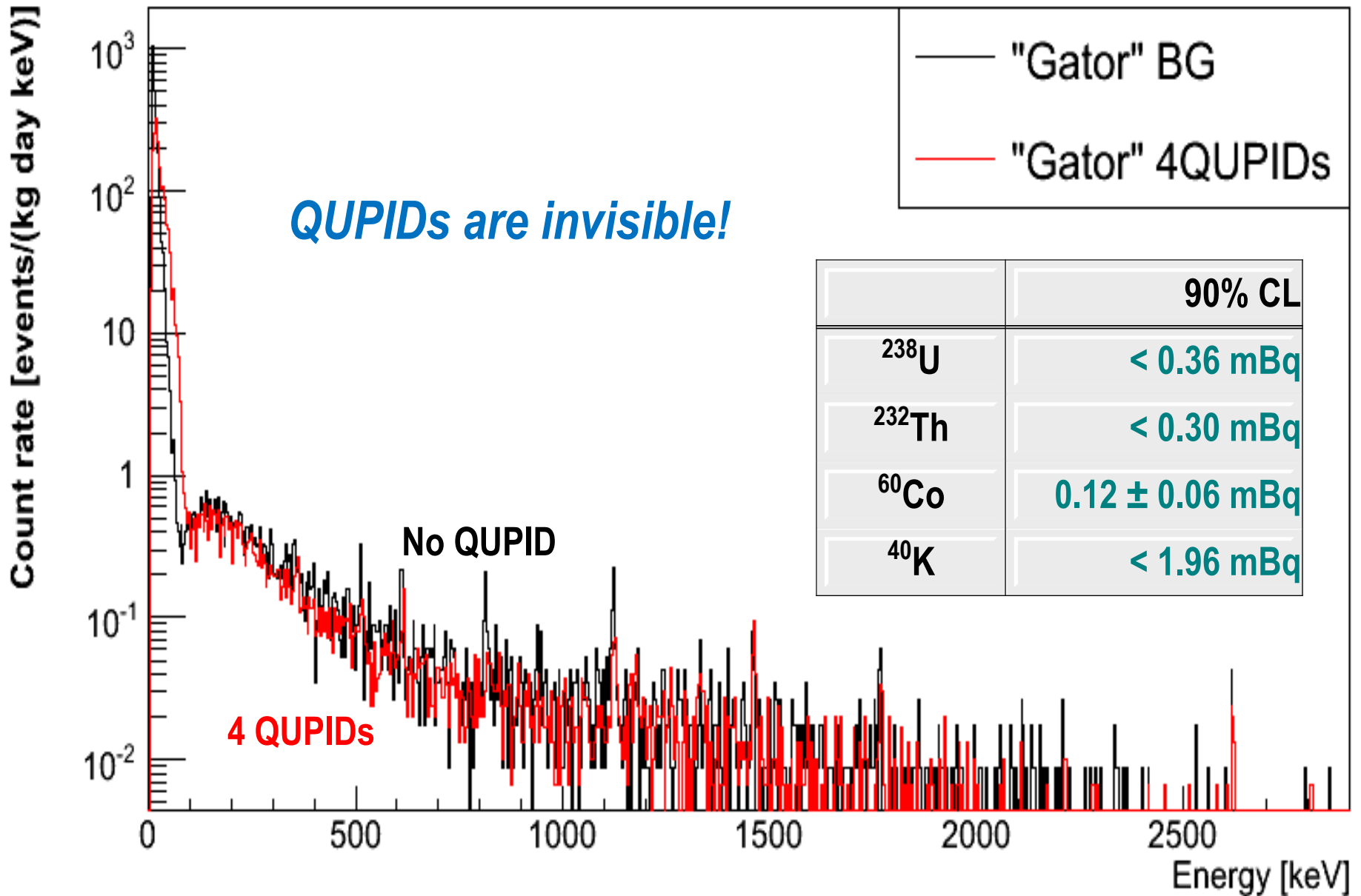



2/25/2010 **Cryogenic System at UCLA (Hanguo Wang's Lab)** *Katsushi Arisaka, UCLA*

# QUPID in the Cooling System

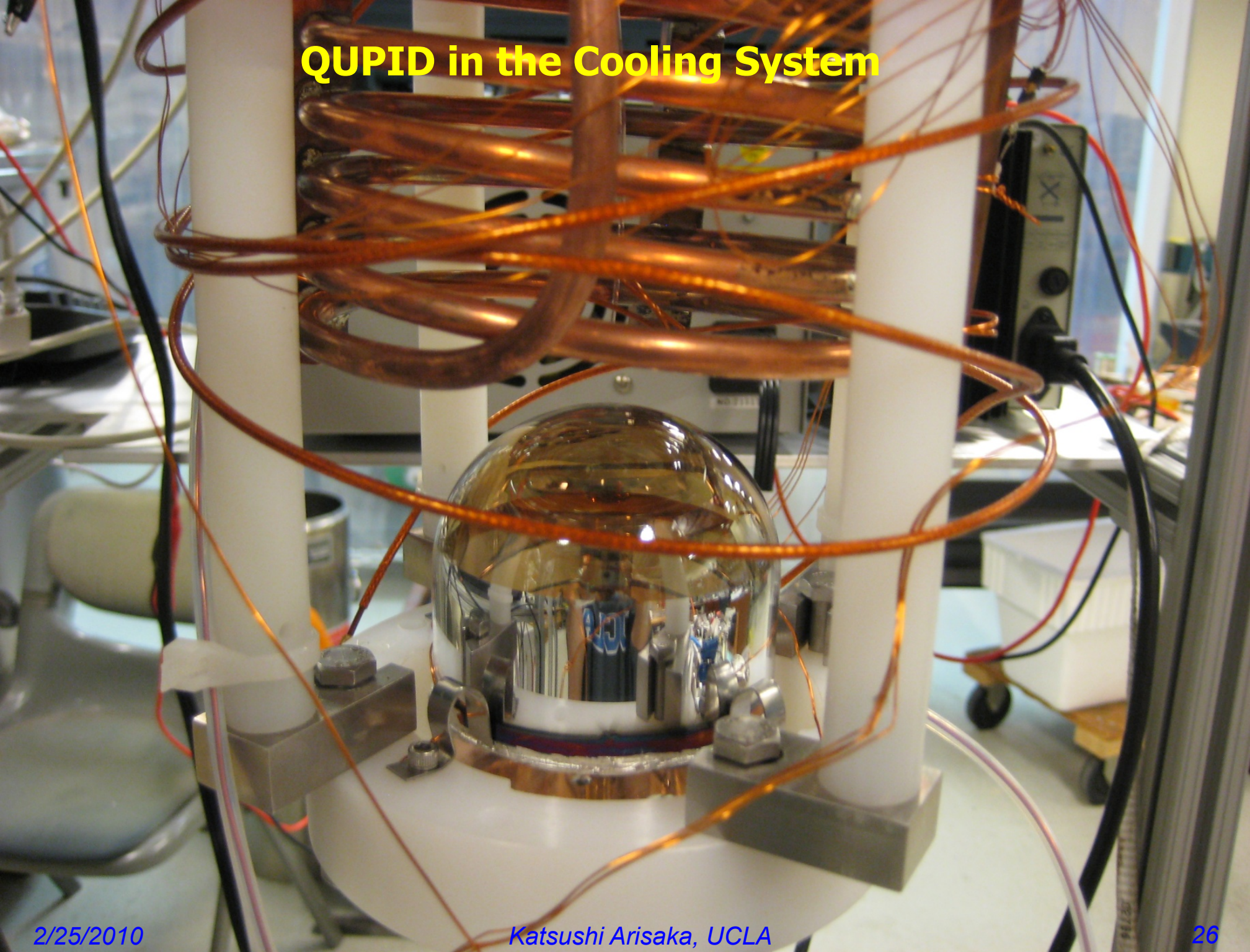

# Electron Bombardment Gain (QHA26)

QHA26 Bombardment Gain Test, Various Temperatures

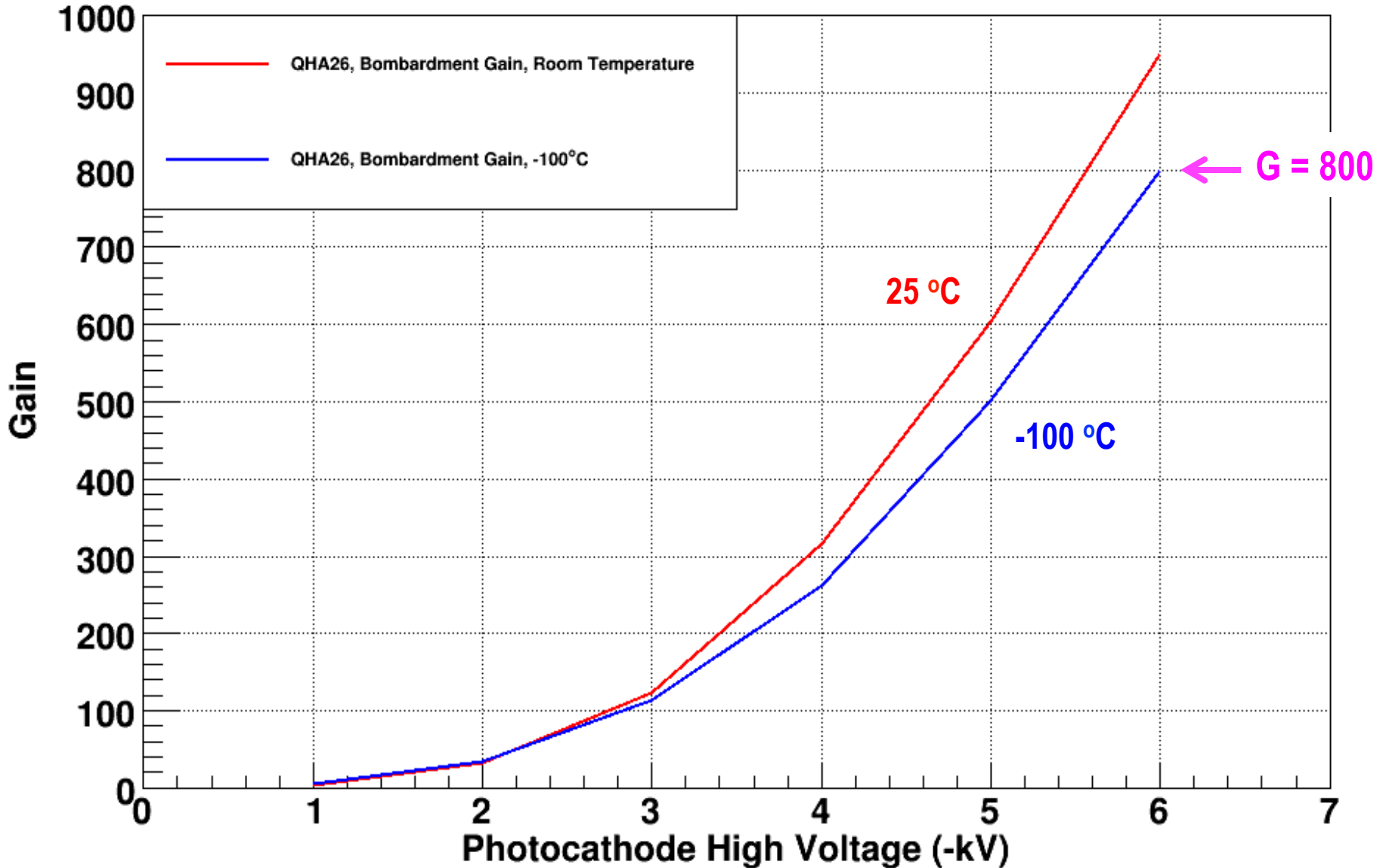

# APD Gain and Leakage (QHA26)

## QHA26 Avalanche Gain and Leakage Current

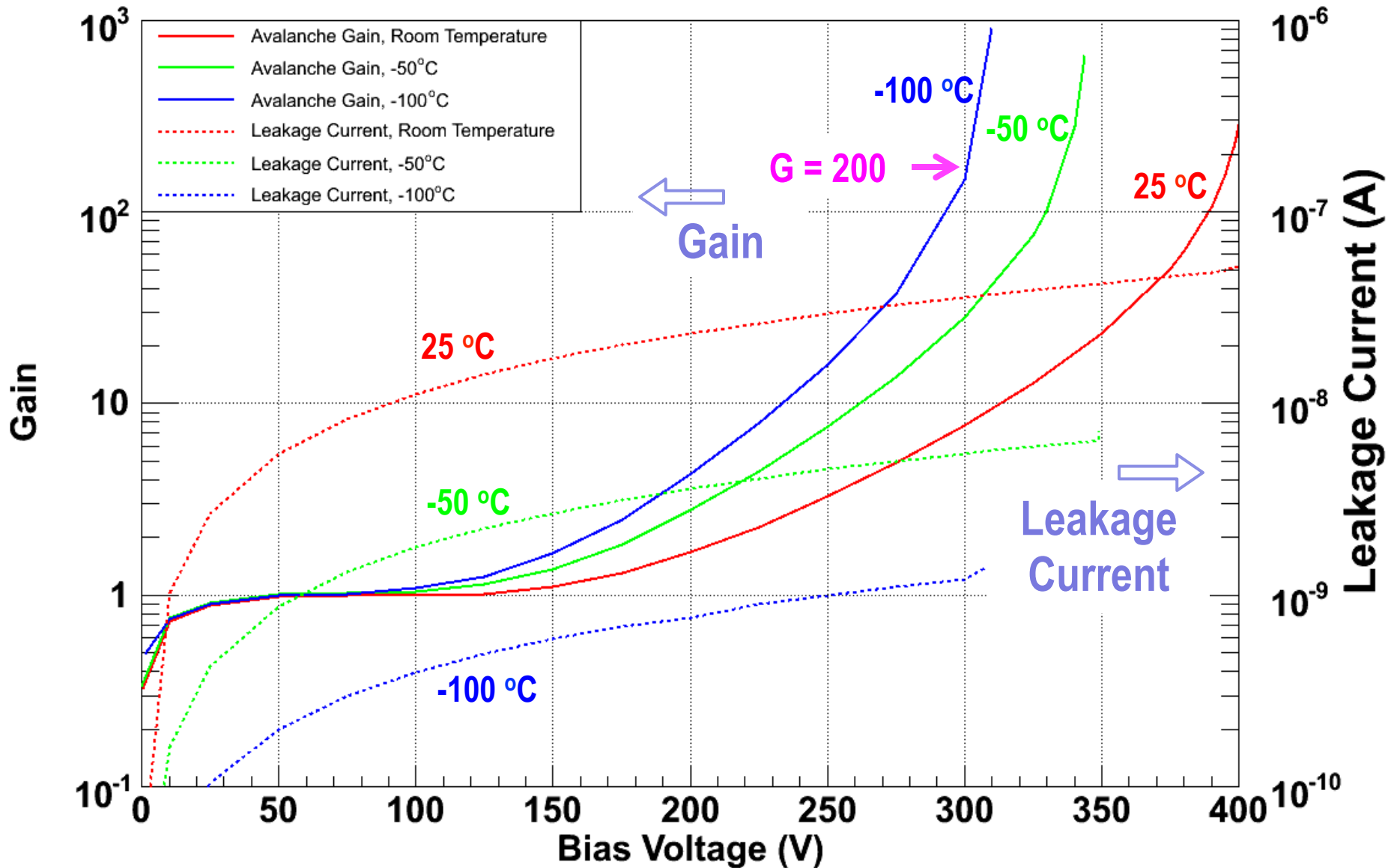

# Systematic Diagram of MAX Readout

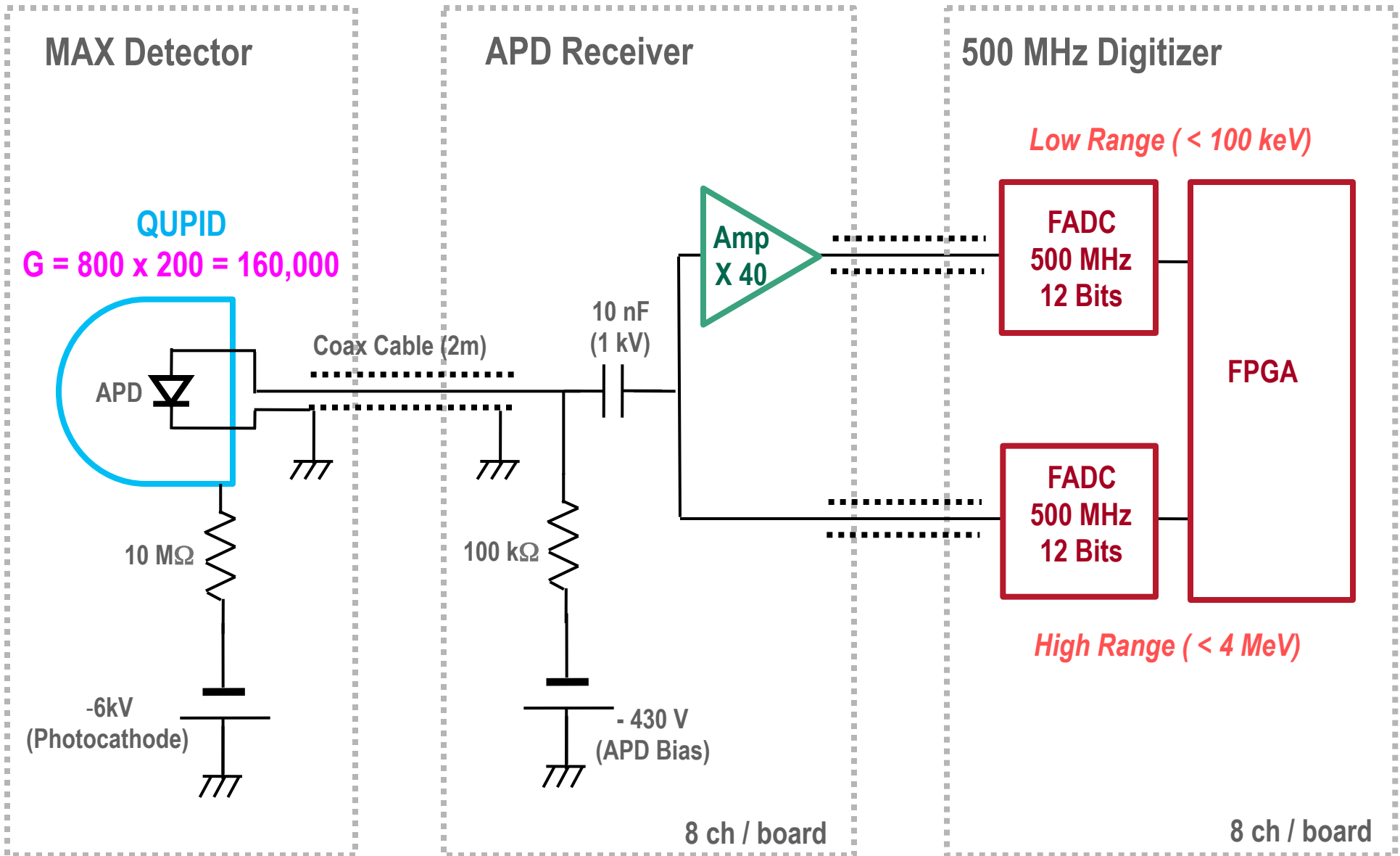

# 1, 2 and 3 PE Distribution with 2m cable

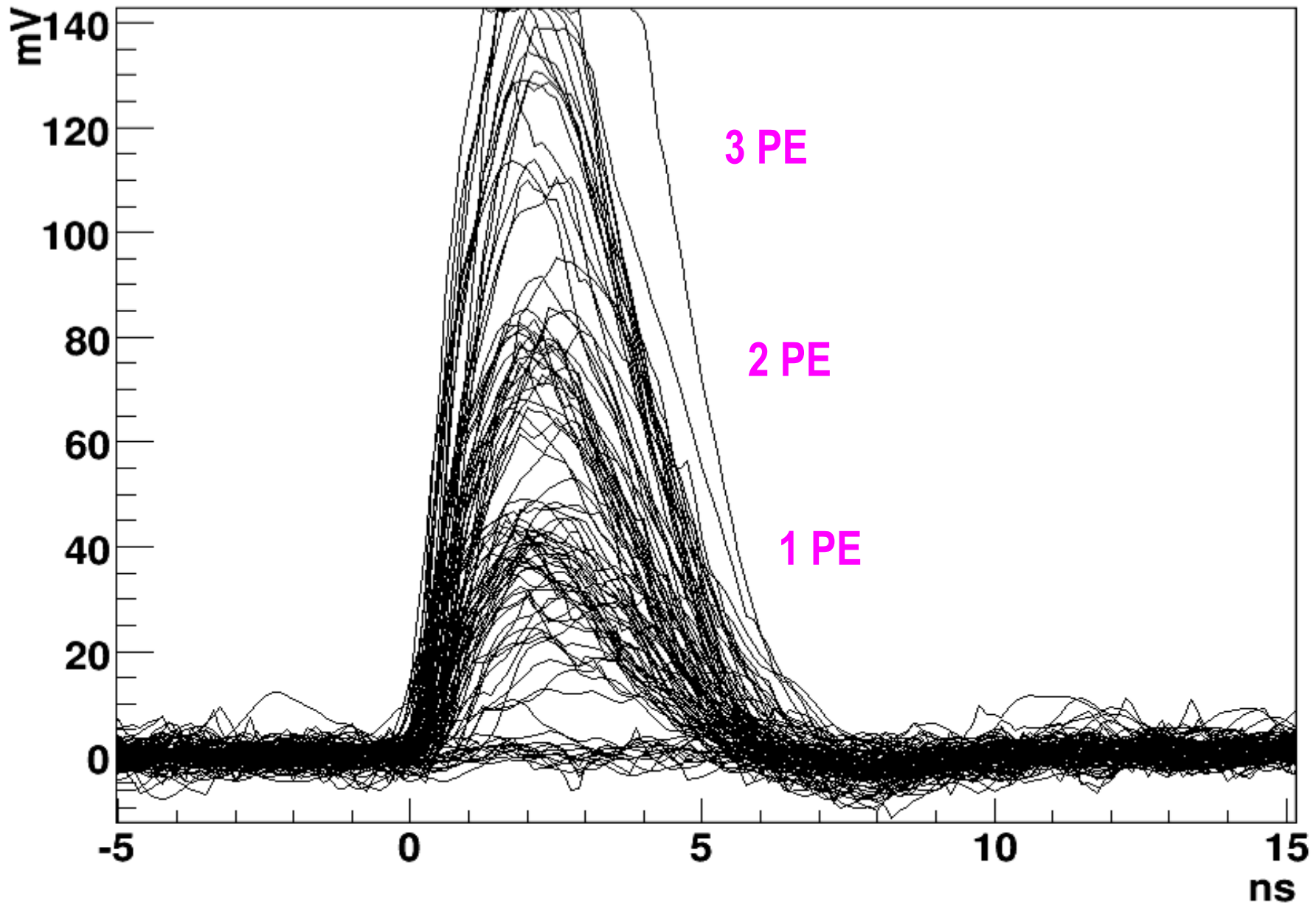

# Summary of QUPID

- **Extremely low radioactivity:** < 1 mBq
  - < 0.1 neutron / year
  - < 10 times lower than conventional low radioactive PMTs.
- **Large diameter:** 3 inch
  - 6 inch is also under investigation.
- **Special Photocathode:** Bialkali LT
  - > 30 % QE at 170 – 450 nm
  - Low resistivity even at Liquid Ar temperature (- 185 °C)
- **True photon counting.**
  - 1, 2, 3... photoelectron peaks clearly visible.
  - 100% collection efficiency.
- **Simple HV supply.**
  - Common HV (-6 kV) for all QUPIDs
  - Resister chain not necessary
- **Currently under operation in Liquid Xenon at UCLA!**

# Expected No. of Photoelectrons per keV in Xe 10 ton (Abs. Length = 10 m, Scat. Length = 50 cm, QE = 30%)

PTFE on Side Wall (Reflectivity = 98%)

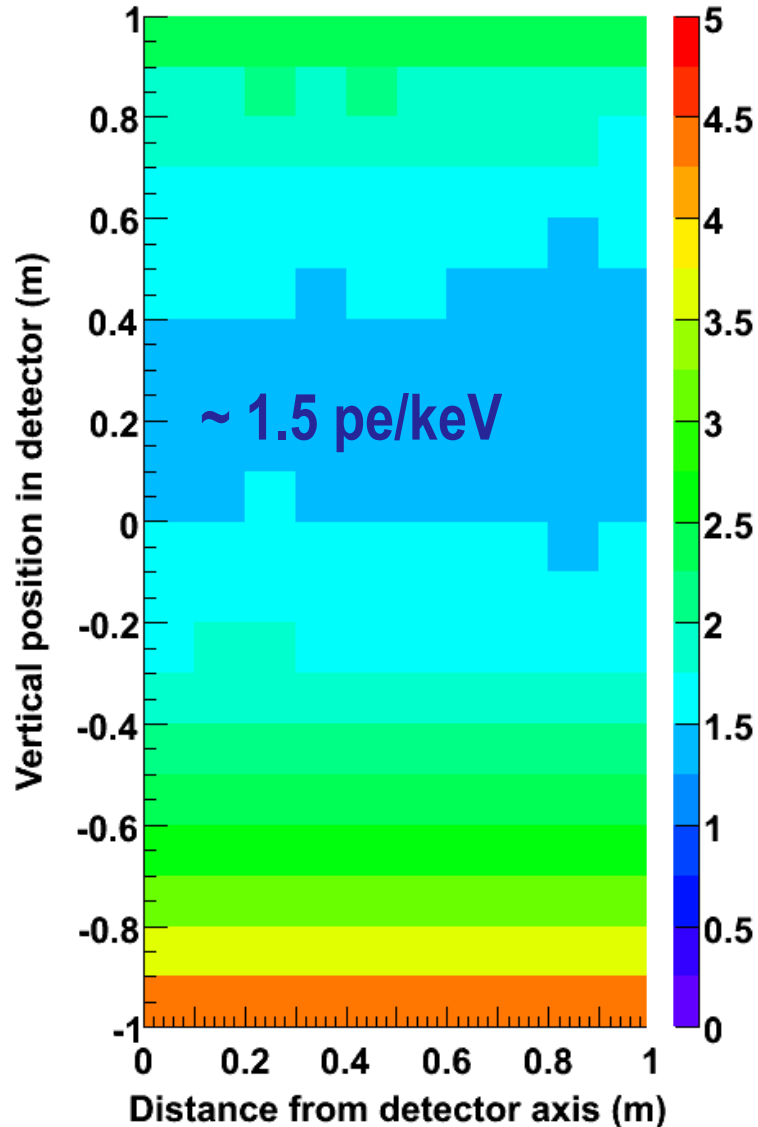

QUPIDs on Side Wall

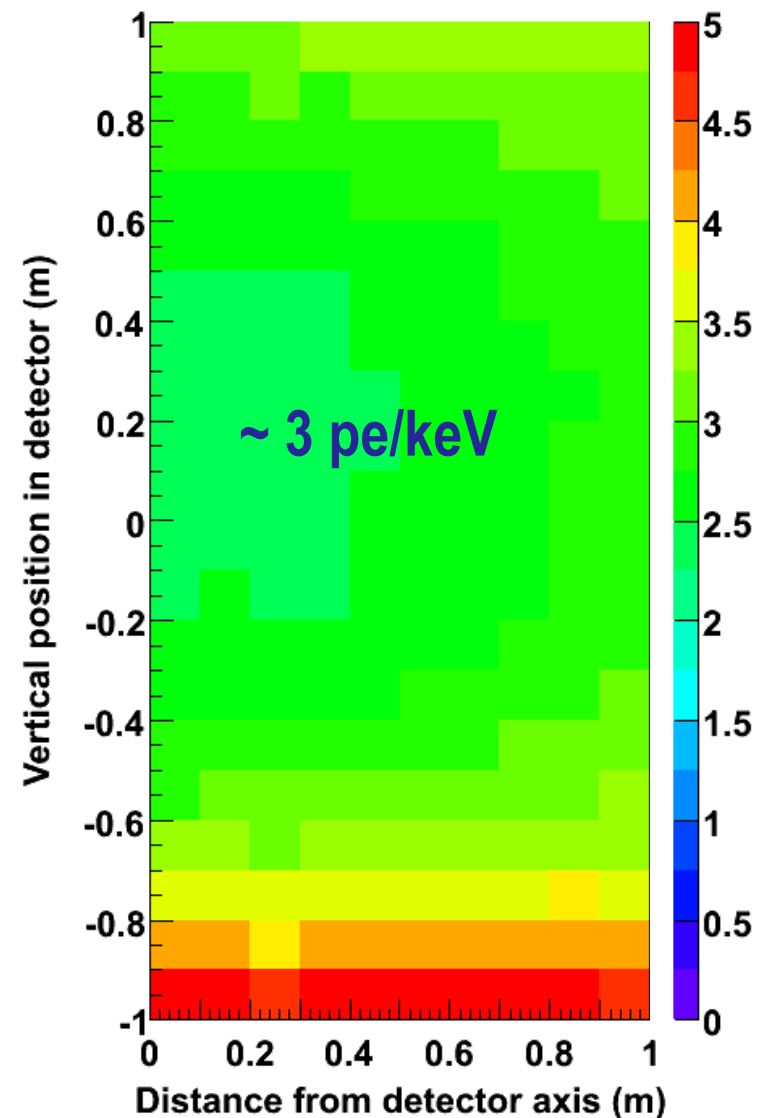

# Xe 10 ton Gamma Background (After Multi-hit Cut and S2/S1 Cut)

Gamma Background (multi-hit cut, S2/S1 cut)

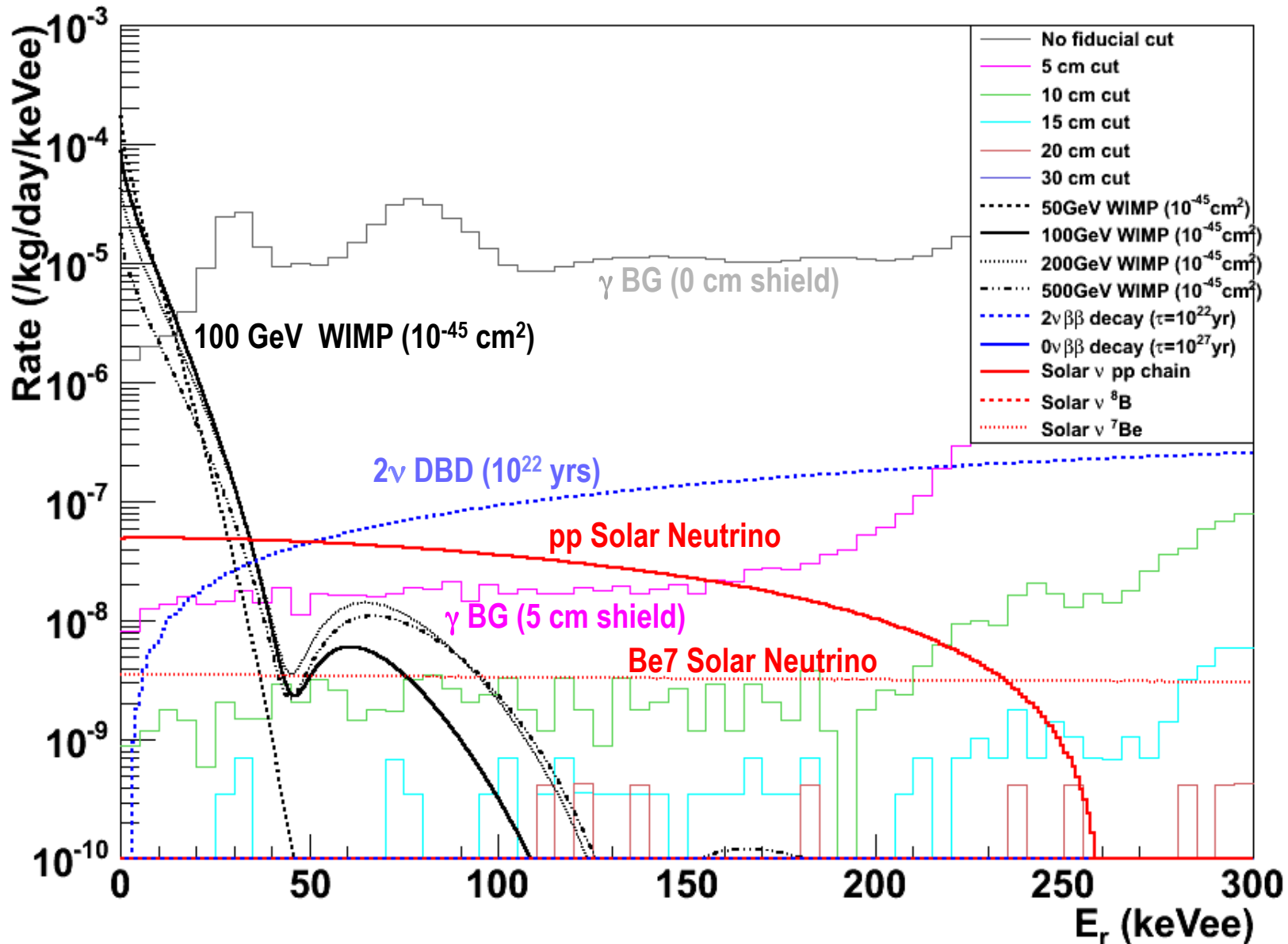

# Expected Background from Gammas and pp Solar Neutrinos (100 Year, Multi-hit Cut, S2/S1 Cut)

pp Solar Neutrino and QUPID Gamma Background (100 years, multi-hit cut, S2/S1 cut)

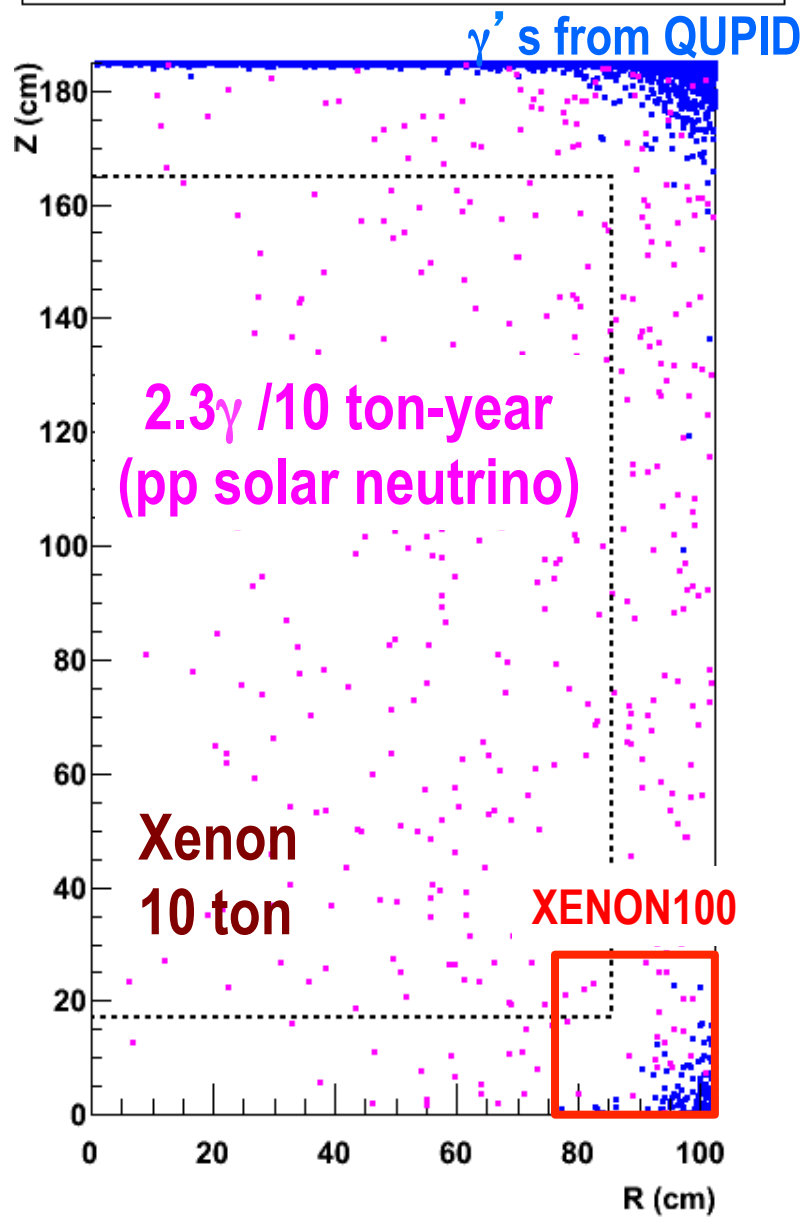

pp Solar Neutrino and QUPID Gamma Background (multi-hit cut, S2/S1 cut)

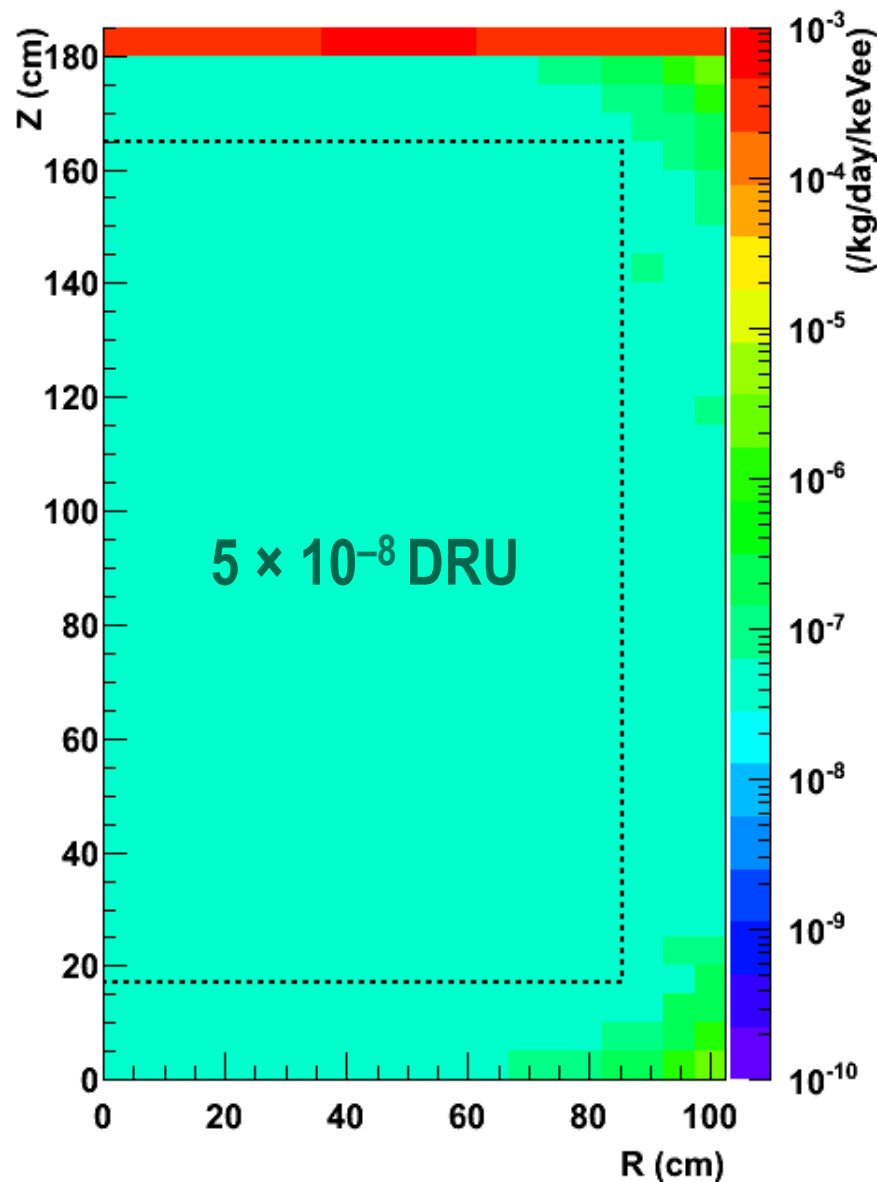

# Xe 10 ton Neutron Background (100 Years)

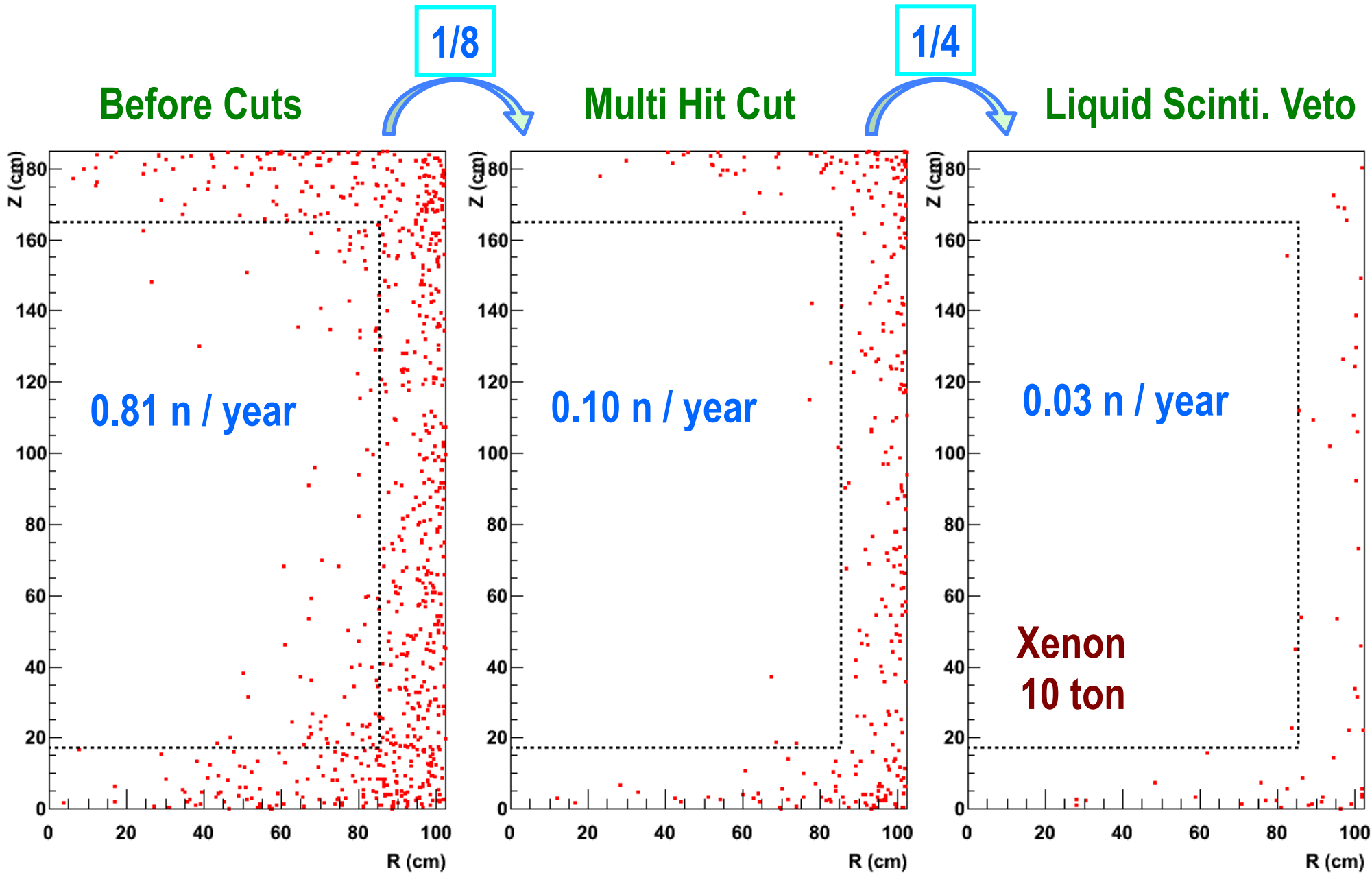

# Ar 5 ton Neutron Background (100 Years)

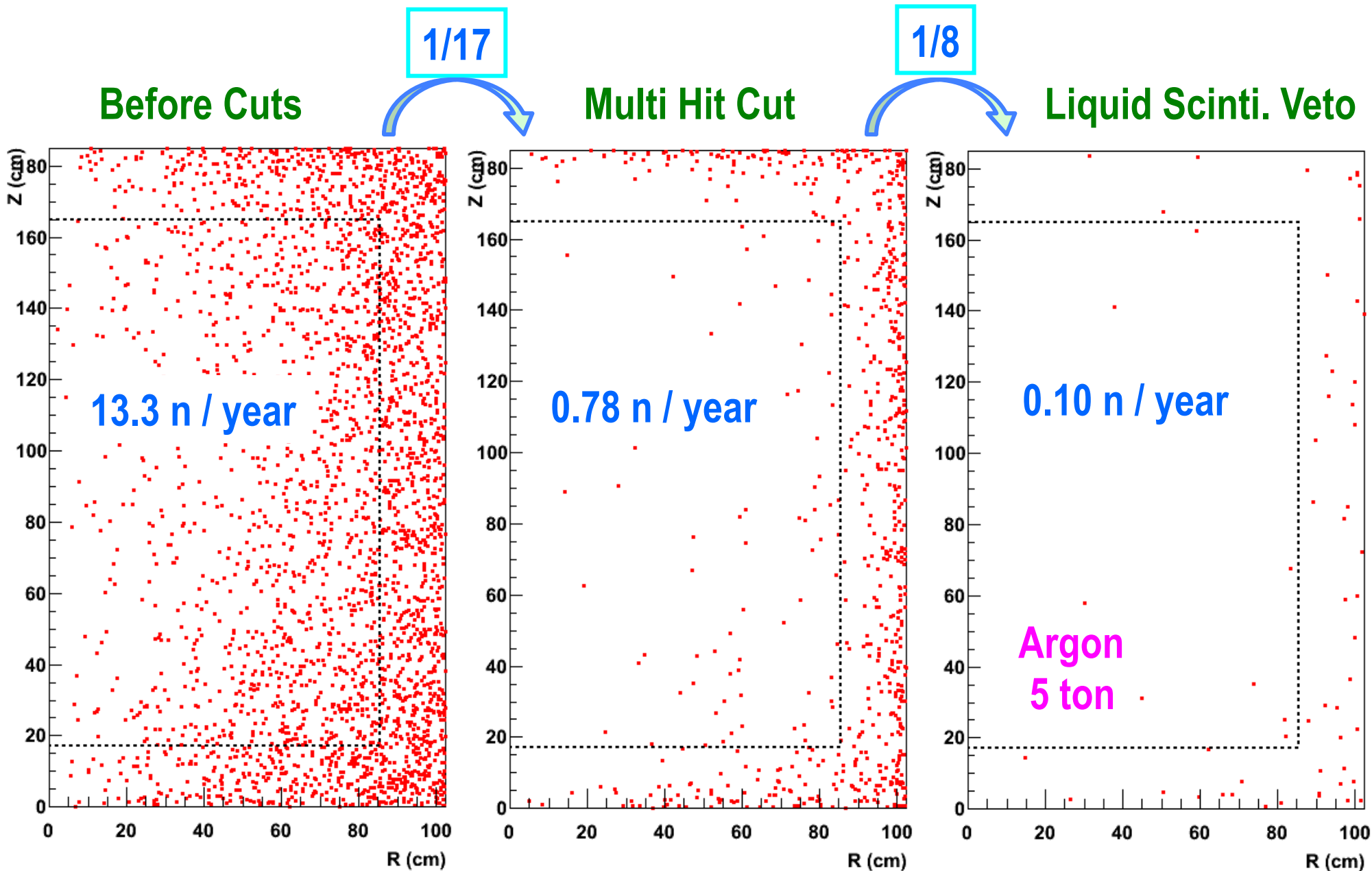

# Ar 50 ton Neutron Background (100 Years)

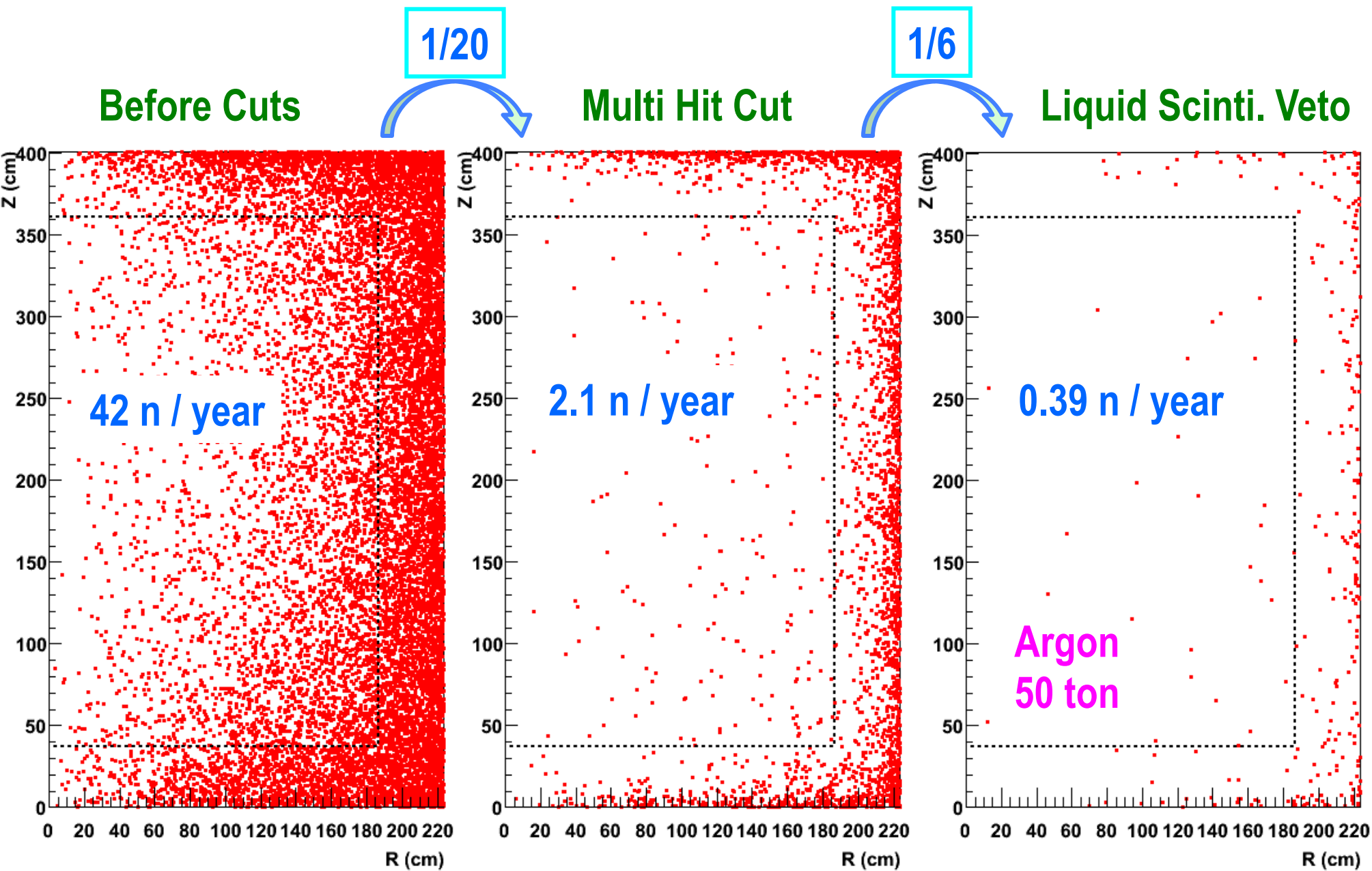

# Summary of MAX G2/G3 & XAX

	MAX G2		MAX G3		XAX	
	Xenon	Argon	Xenon	Argon	$^{129/131}\text{Xe}$	$^{136}\text{Xe}$ (80%)
<b>Dimension</b>						
<i>Detector Size</i>	1m x 1m	2m x 2m	2m x 2m	4m x 4m	2m x 2m	
<i>Total Mass</i>	2.2 ton	10 ton	20 ton	70 ton	13 ton	7 ton
<i>Fiducial Mass</i>	1.1 ton	5 ton	10 ton	50 ton	6 ton	4 ton
<b>QUPID</b>						
<i>Top</i>	121 (3")	595 (3")	595 (3")	661 (6")	595 (3")	
<i>Side</i>	0	672 (6")	672 (6")	2423 (6")	672 (6")	
<i>Bottom</i>	121 (3")	163 (6")	163 (6")	661 (6")	163 (6")	
<b>No.WIMP / year (<math>10^{-45} \text{ cm}^2</math>)</b>						
<i>Mass = 20 GeV</i>	23	–	230	–	138	92
<i>50 GeV</i>	71	25	710	250	426	284
<i>100 GeV</i>	56	42	560	420	336	224
<i>200 GeV</i>	33	36	330	360	198	132
<i>500 GeV</i>	14	19	140	190	84	56
<b>Backgrounds / year</b>						
<i>Gammas</i>	0.07	0.00	0.01	0.00	0.07	0.01
<i>Neutrons (w/o LS)</i>	0.10	0.78	0.10	2.1	0.10	0.00
<i>Neutrons (w/ LS)</i>	0.03	0.10	0.03	0.39	0.03	0.00
<b>Neutrinos / year</b>						
<i><math>0\nu</math> DBD (<math>10^{27} \text{ yr}</math>)</i>	0.4	–	3.3	–	–	30
<i>pp-solar</i>	–	–	–	–	2500	–
<i>Supernova (10 kpc)</i>	11	14	95	141	56	39

# Conclusions

- **MAX** is the ideal G3 dual detectors at DUSEL.
  - **10 Ton Xenon + 50 Ton Argon** (fiducial)
  - ~5 events each / year at  $10^{-47} \text{ cm}^2$
- If the cross sections is  $> 10^{-46} \text{ cm}^2$ , precise determination of WIMP mass and cross section is possible.
  - Two independent energy spectrums by Xenon & Argon
  - Two independent annual modulations by Xenon & Argon
- $4\pi$  coverage by QUPID ensures high photon yield with no radioactivity.
  - ~3 pe/ keV,  $< 1 \text{ mBq}$ ,  $< 0.1 \text{ neutron/year}$
  - First applications on XENON 1ton and Darkside 50kg underway
  - QUPID has been operated in Liquid Xenon successfully!