

Dark Matter Searches by Liquid Xenon and Argon TPC **XENON100, DarkSide50, XENON1Ton, MAX and XAX**

Katsushi Arisaka

***University of California, Los Angeles
Department of Physics and Astronomy***

arisaka@physics.ucla.edu

UCLA DM2010 Conference

UCLA DARK MATTER 2010

[Home](#)

[Talks](#)

[Agenda \(PDF\)](#)

[Attendees \(PDF\)](#)

[Contact](#)

NINTH UCLA SYMPOSIUM ON SOURCES AND DETECTION OF DARK MATTER AND DARK ENERGY IN THE UNIVERSE



California

February 24 - 26,
2010

Marriott Hotel
Marina del Rey,

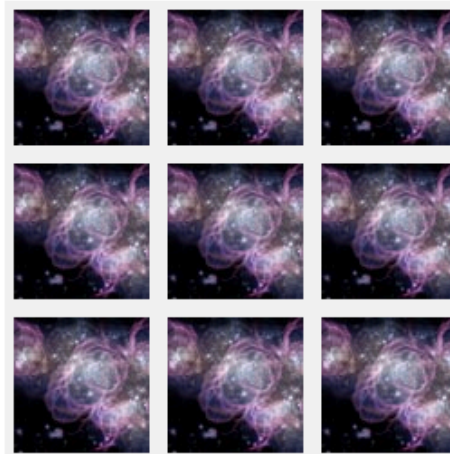

DARK MATTER 2010 SCIENTIFIC TOPICS

- Precision cosmology
- Latest results on the measurements of the equation of state of dark energy and new experiments in progress or being planned
- Models for dark matter including Kaluza, Klein, extra dimensions, SUSY, etc. theories
- Worldwide results from the direct search for dark matter

Advisory committee: Elena Aprile (Columbia), Elliott Bloom (SLAC), Blas Cabrera (Stanford), David Cline (UCLA), Ruth Daly (Penn State), John Ellis (CERN), Katherine Freese (U. Mich.), Joshua Frieman (FNAL), Rene Ong (UCLA), John Peoples (FNAL), Piergiorgio Picozza (INFN Rome), Joel Primack (UCSC), Leszek Roszkowski (Sheffield), Andre Rubbia (CERN), Max Tegmark (MIT), Ned Wright (UCLA).

NEWS & UPDATES

- ▶ [New talks added March 3, 2010.](#)

LOCAL TRANSPORTATION

- ▶ [Parking and transit](#)
- ▶ [Los Angeles Metro](#)
- ▶ [Big Blue Bus](#)

LINKS OF INTEREST

- ▶ [UCLA Physics & Astronomy](#)
- ▶ [Weather](#)

Talk Outline

➤ Introduction

- What is Dark Matter? How to detect?
- CDMS vs. XENON

➤ XENON100

- Detector System
- Current Status, Preliminary Results

➤ QUPID

- Radiation Free Photon Detectors

➤ Future Multi-ton Detectors

- XENON1T and DarkSide50
- MAX and XAX

Introduction

Seven Phases of Cosmic Evolution

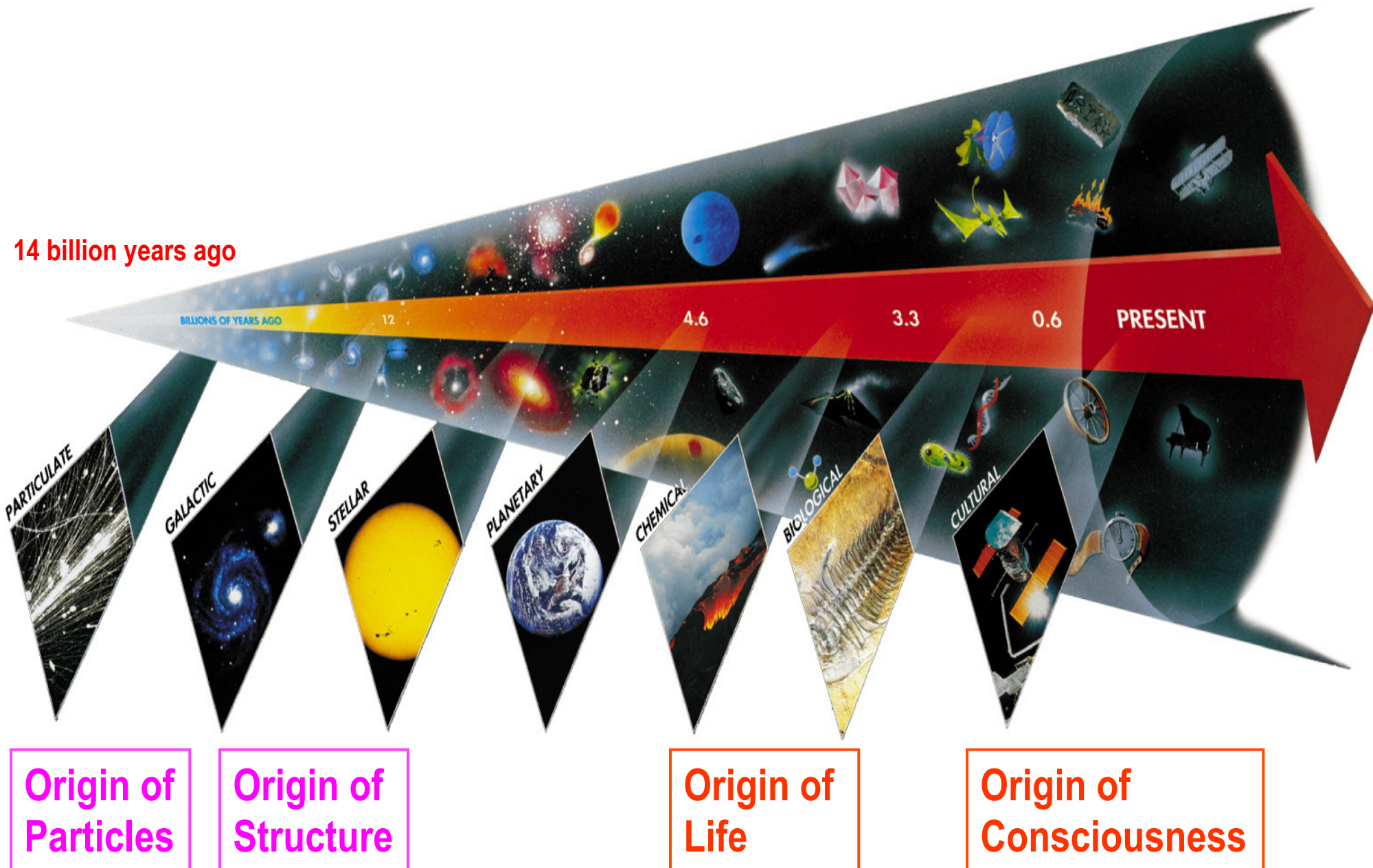

Brain

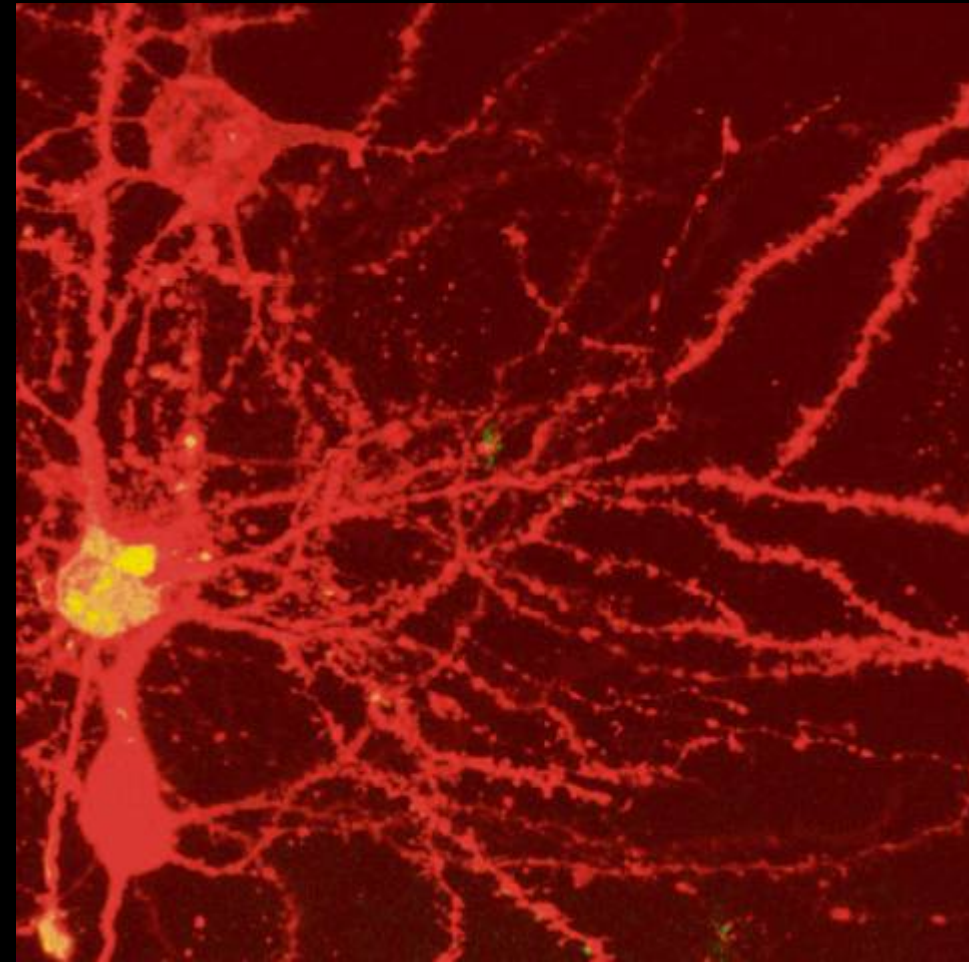

100 Billions Neurons

Universe

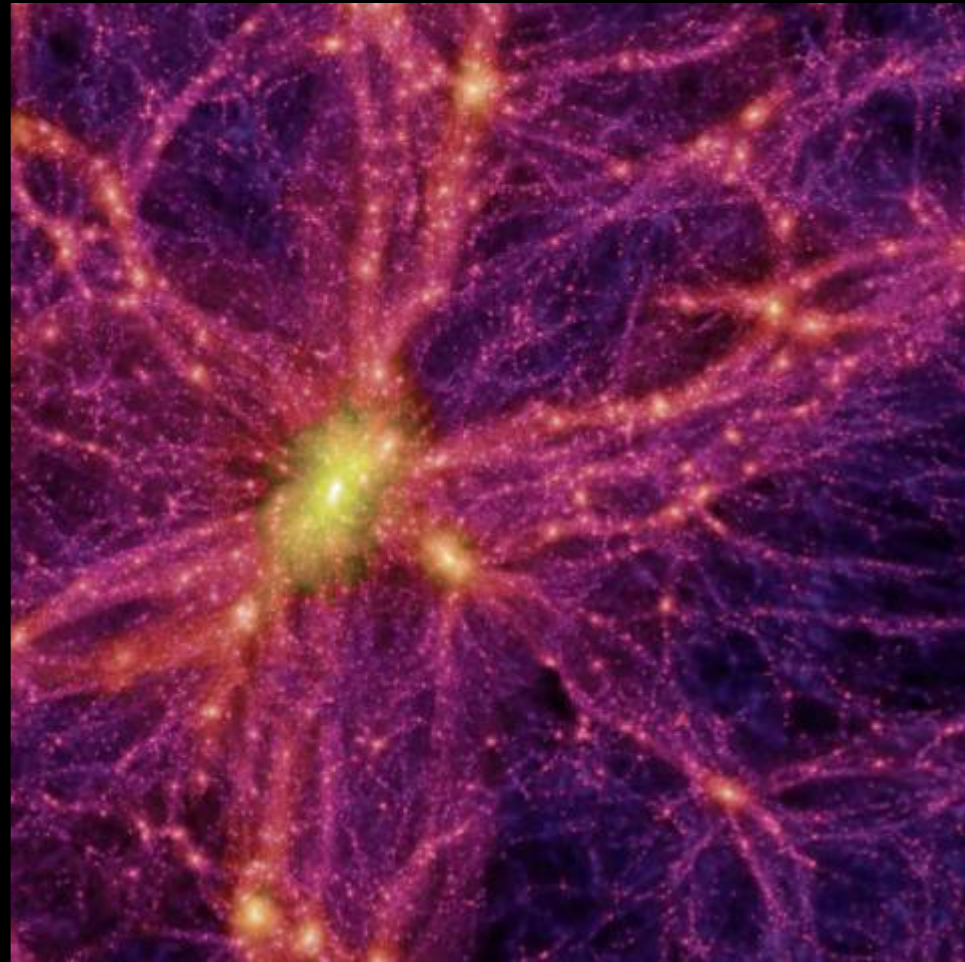

100 Billions Galaxies

Formation of Structure in the Universe

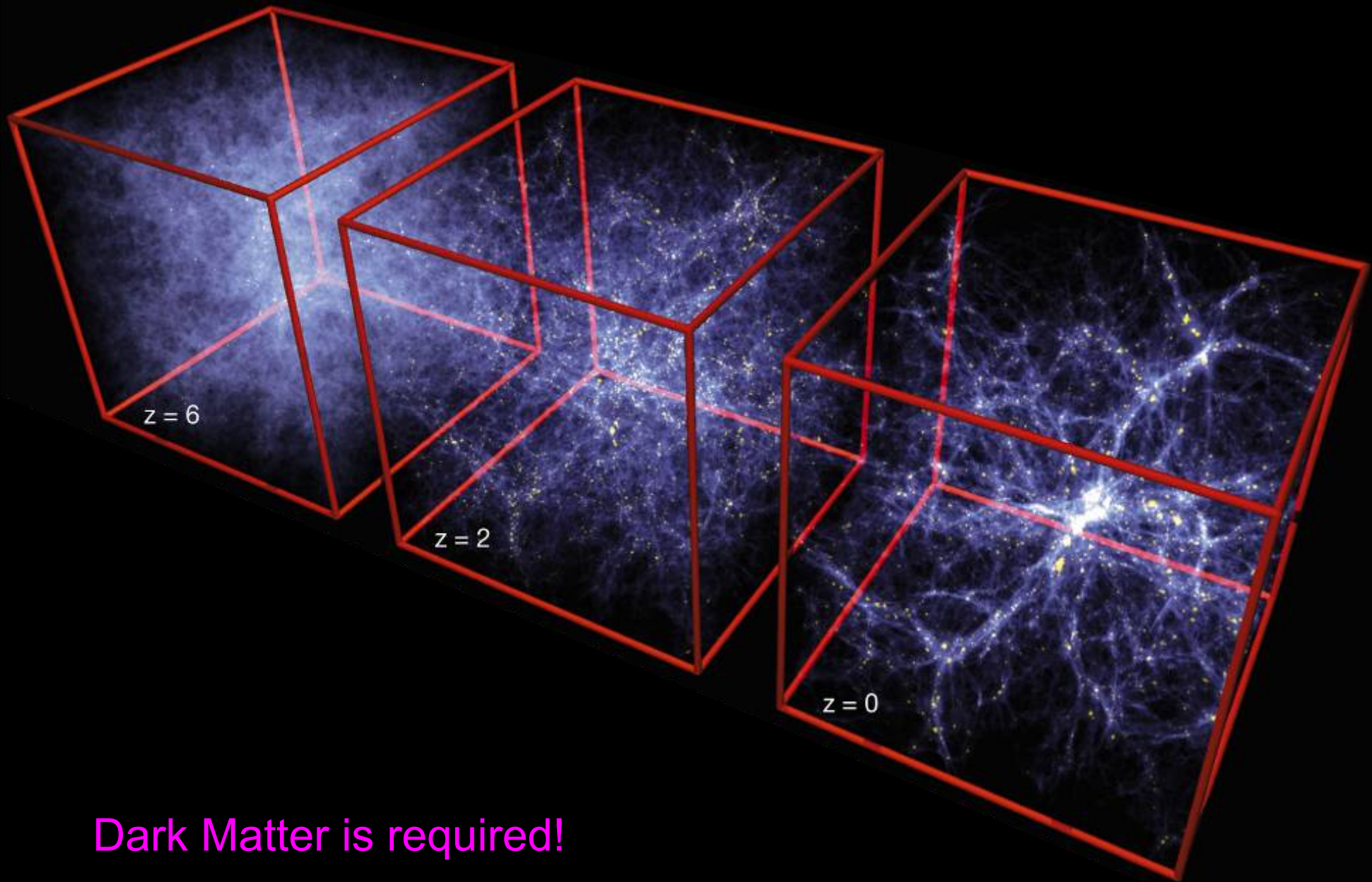

Dark Matter is required!

“Fossils” from the Earliest Universe

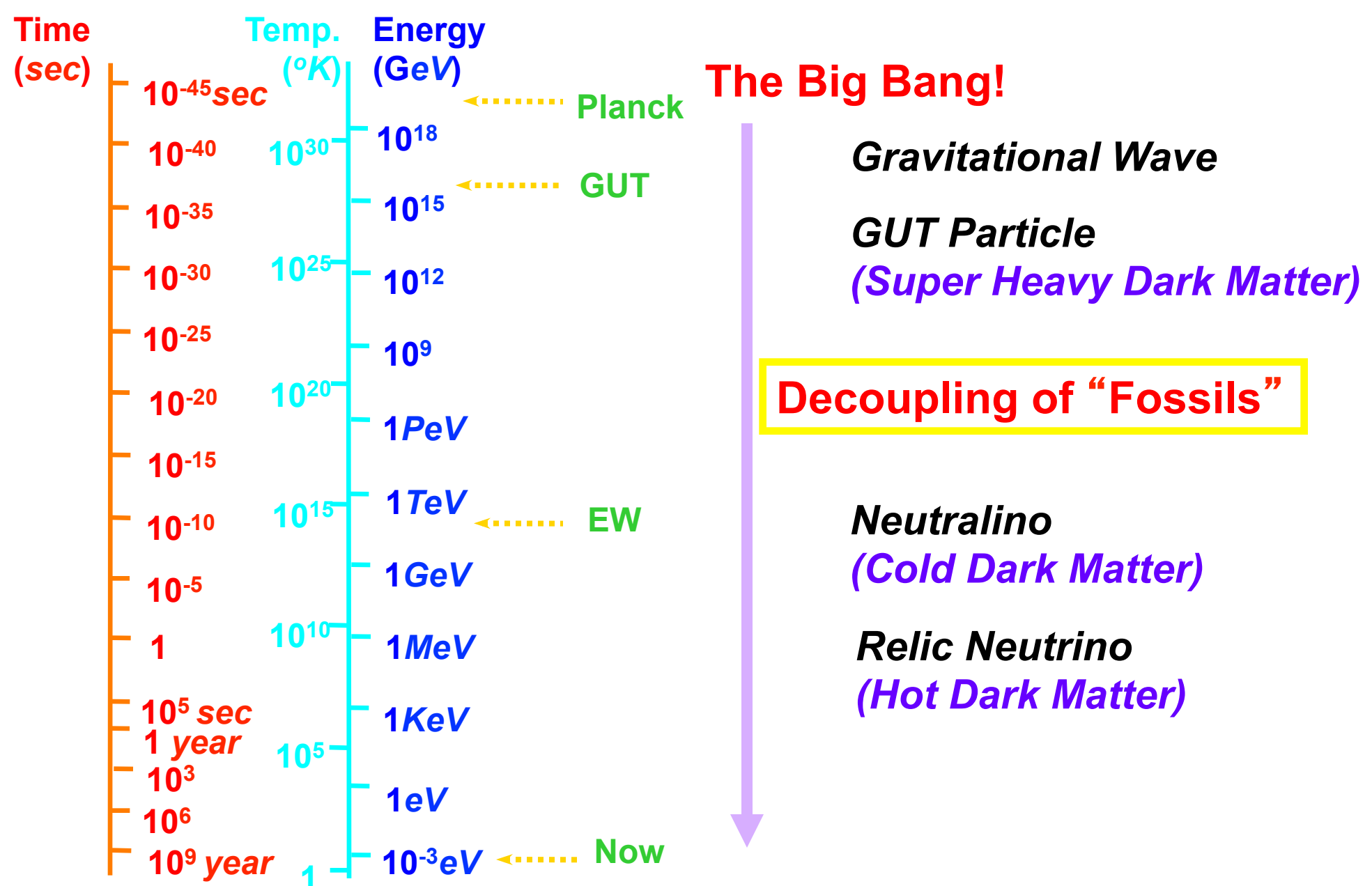

What is Dark Matter?

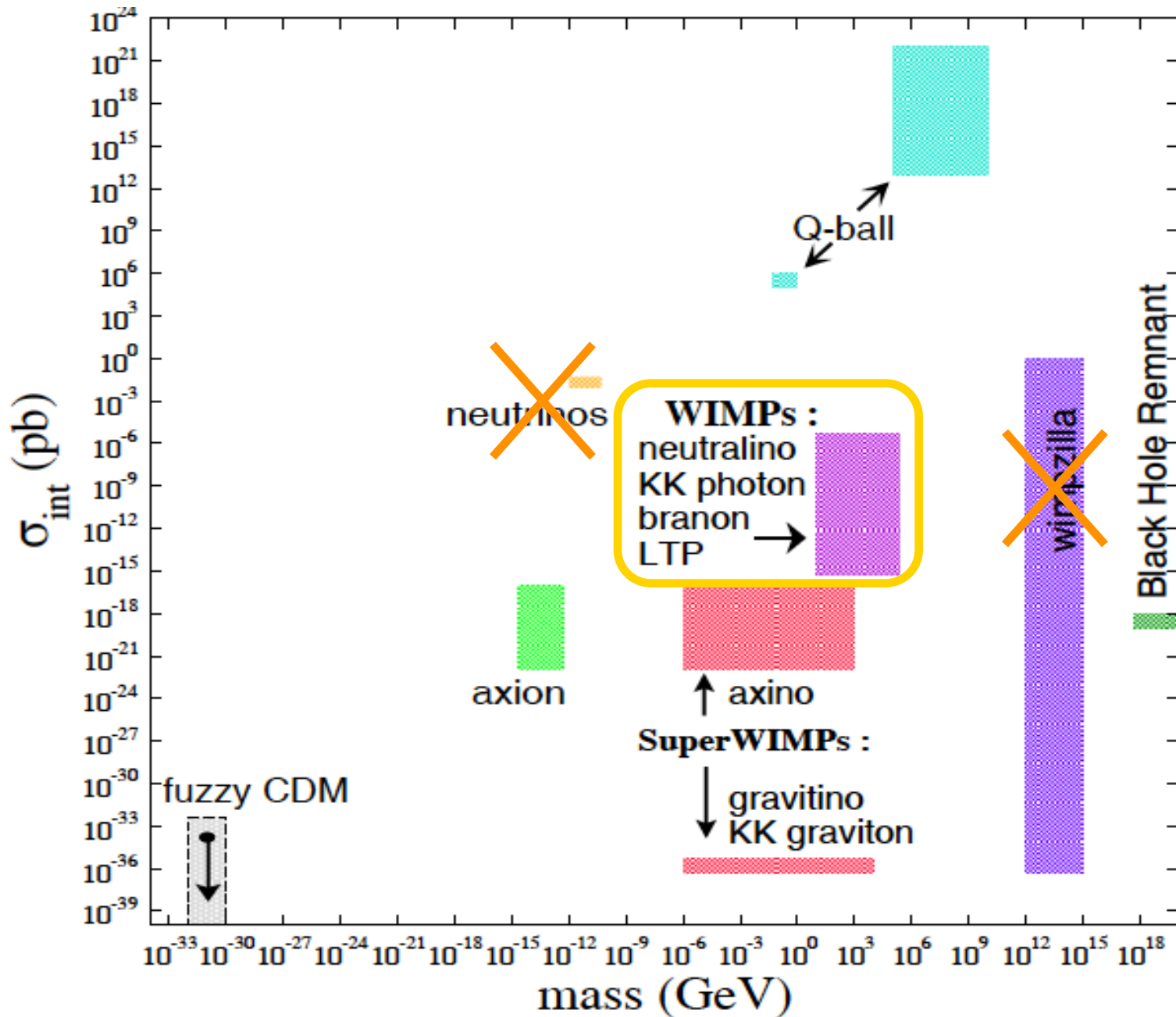

Target Mass Dependence of WIMP Cross Section

cross section 10^{-44} cm^2 , WIMP mass 100 GeV

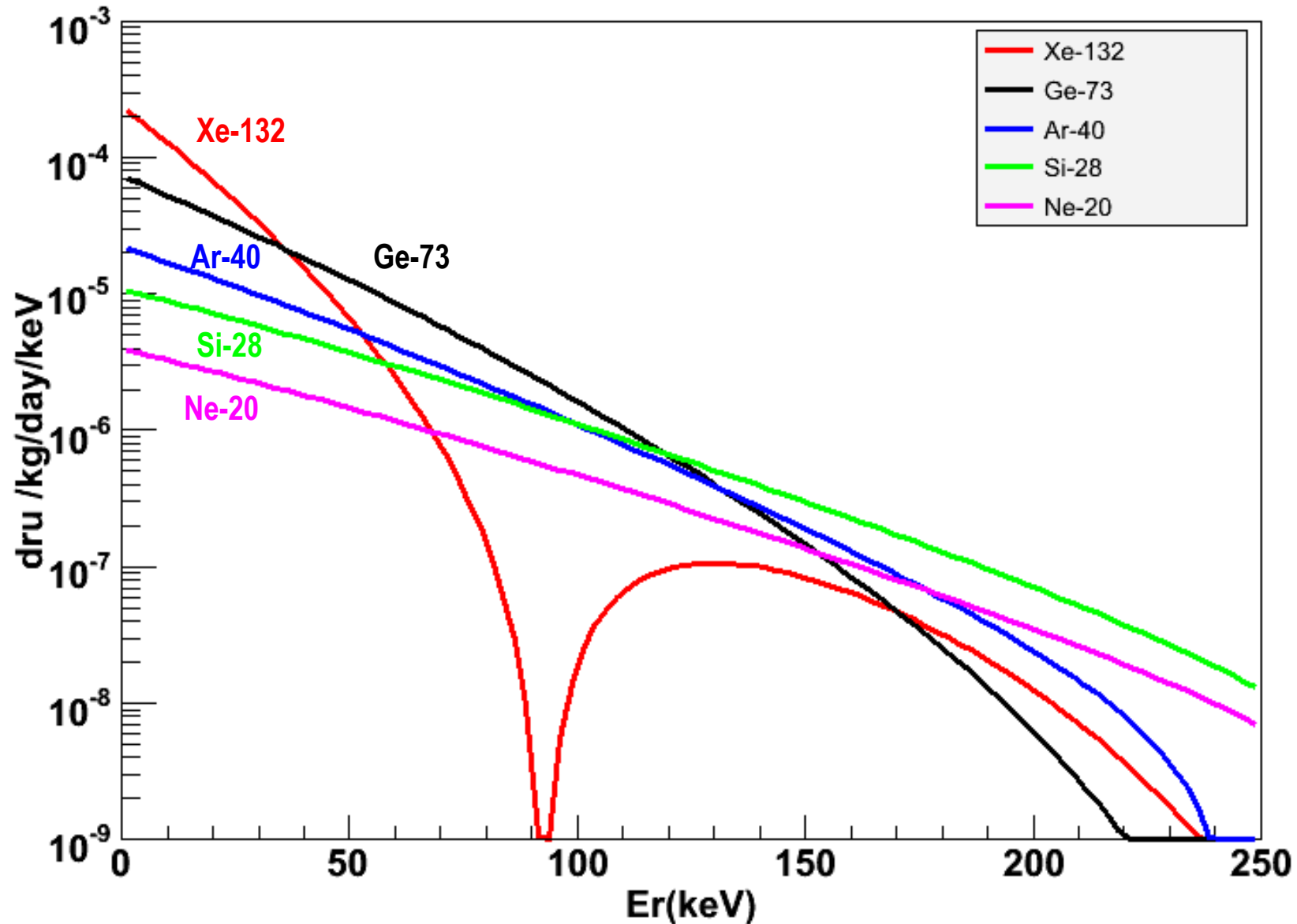

Detection Technique

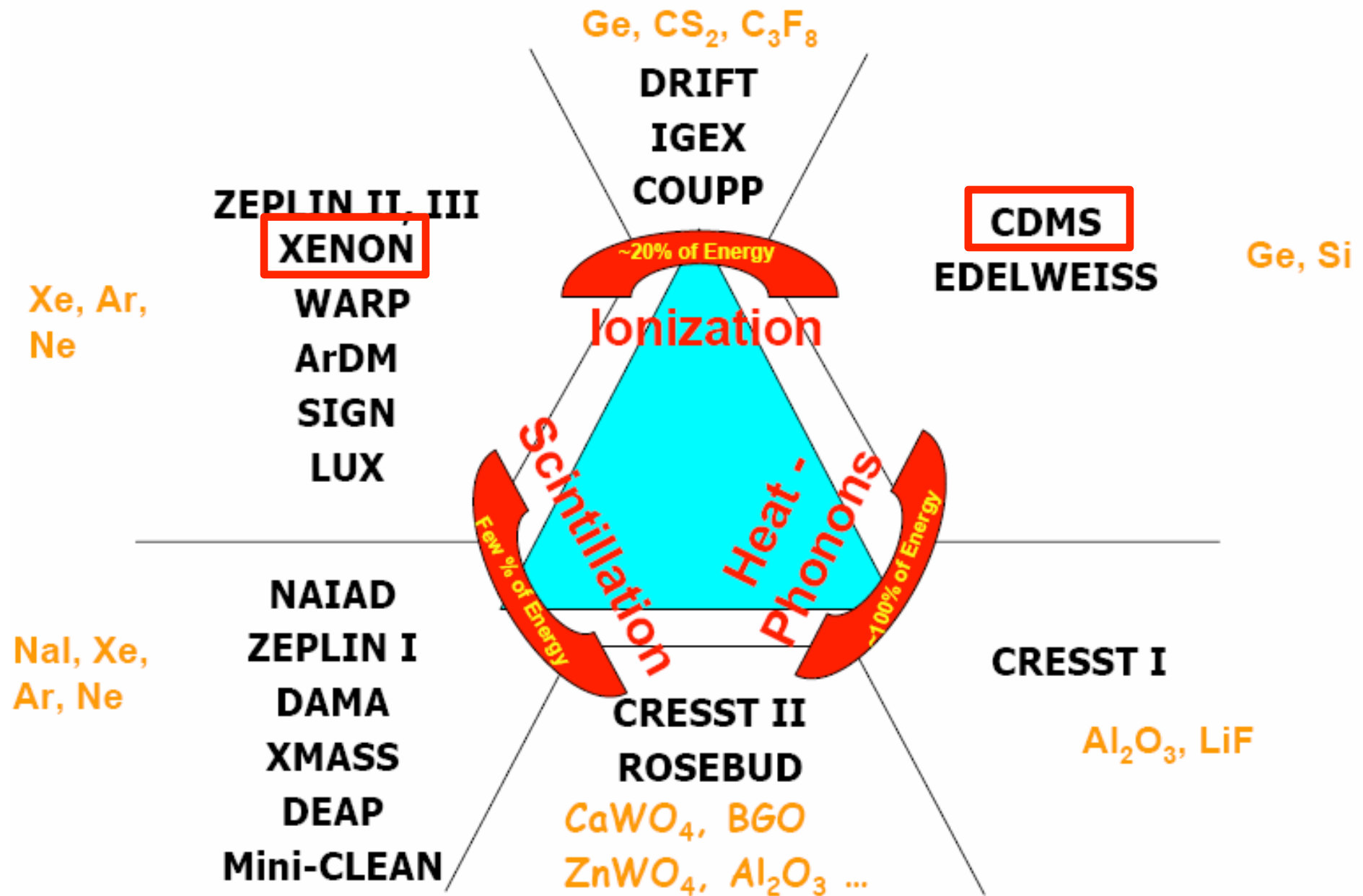

Double-Phase Noble Liquids

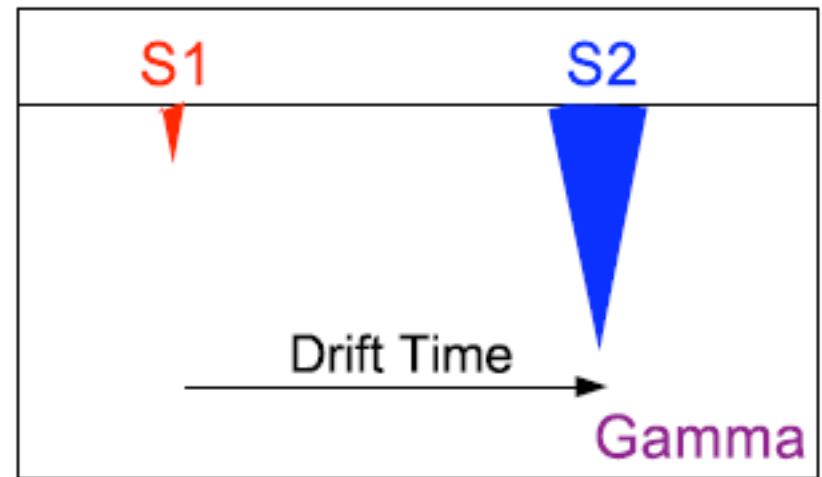
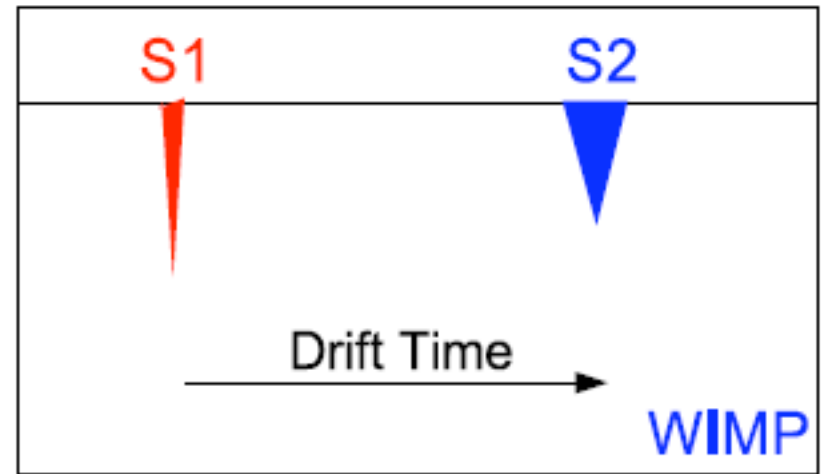
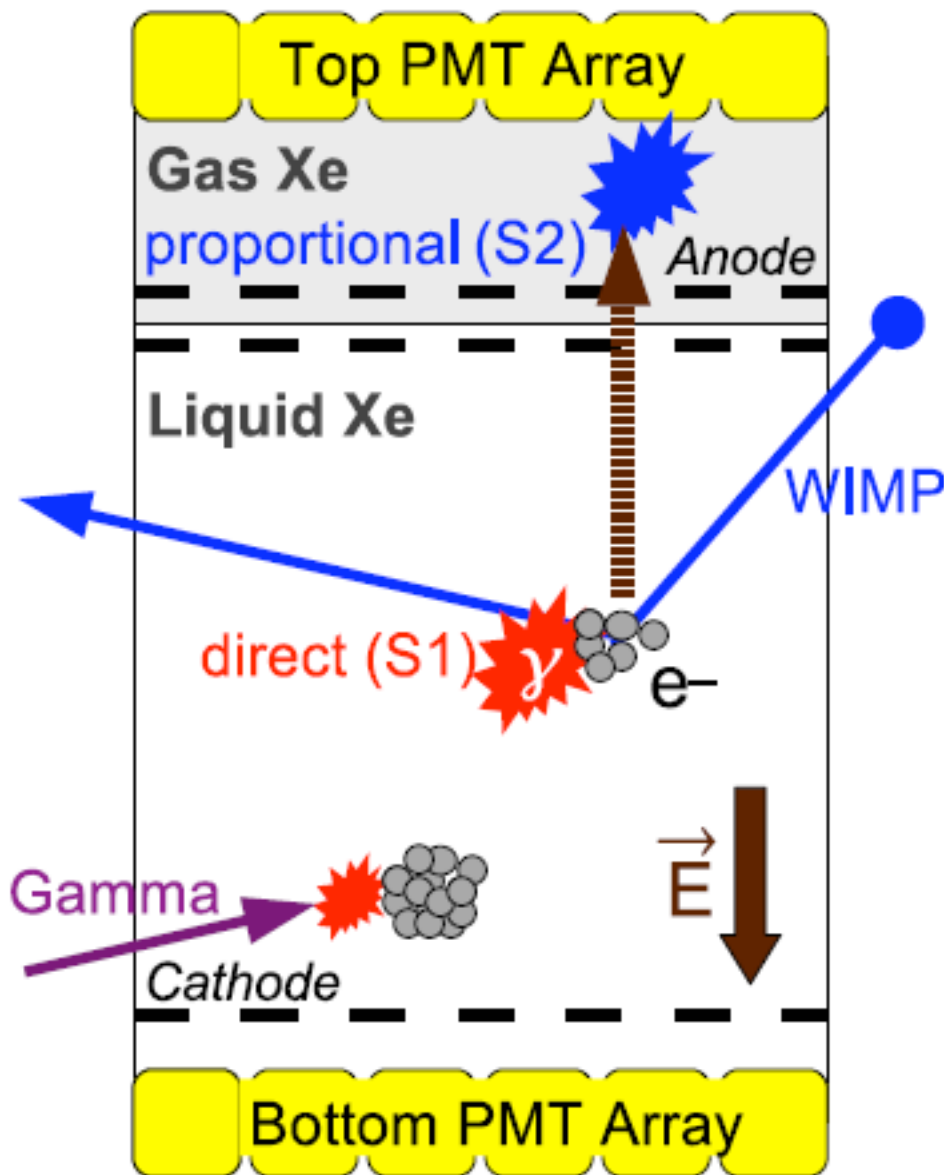

$$(S2/S1)_{WIMP} \ll (S2/S1)_{Gamma}$$

XENON Box: March 12, 2006



XENON10 Detector

3/6/2010

Katsushi Arisaka, UCLA

13

XENON10 Results (2007)

136 kg-days Exposure = 58.6 live days x 5.4 kg x 0.86 (ϵ) x 0.50 (50% NR)

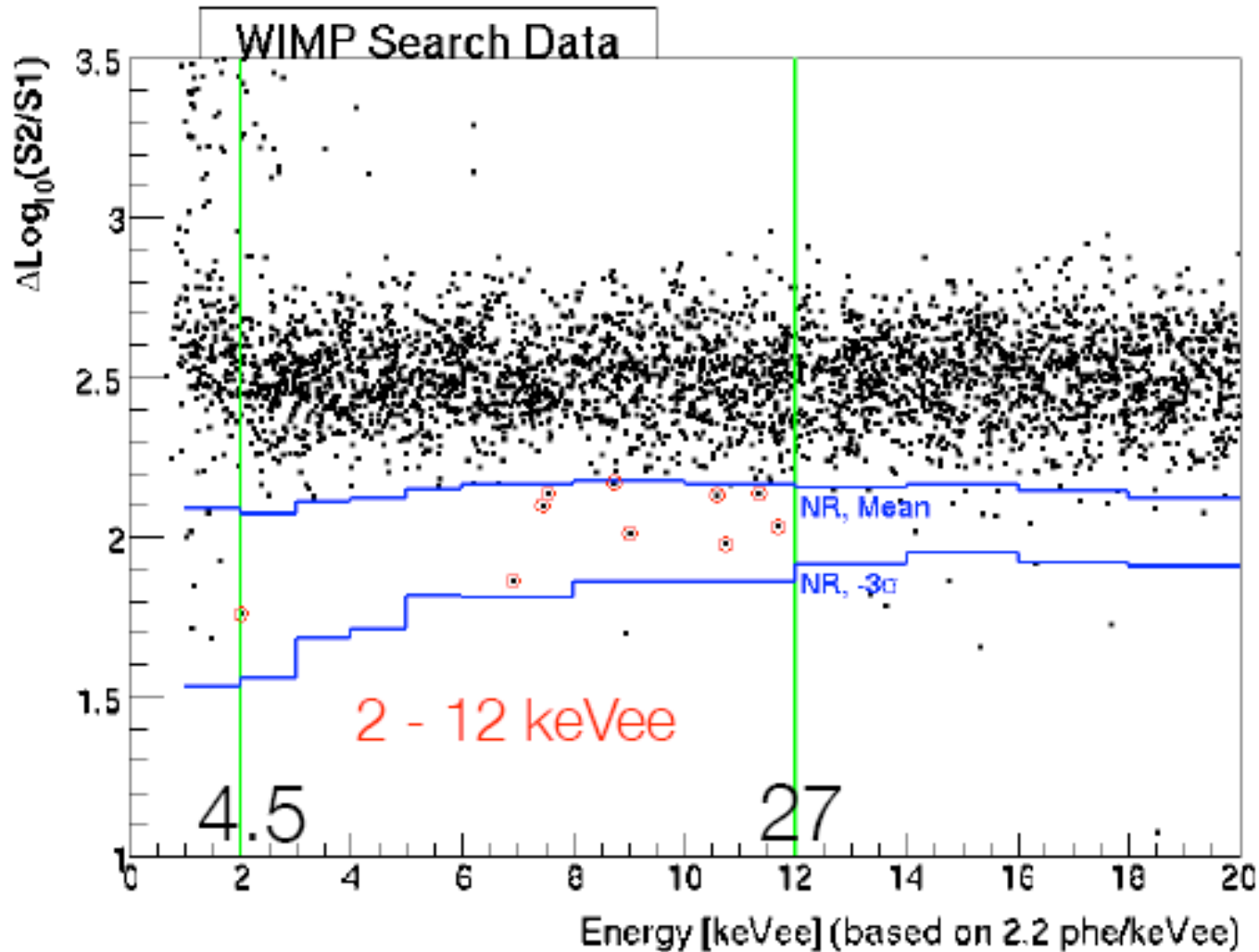

NR Energy scale: use a constant 19% Quenching Factor

$$E_r = E_e / L_{\text{eff}} \cdot S_e / S_r = S_{1\text{tot}} (\text{pe}) / 3.0 \text{ pe/keV} / 0.19 * 0.54 * 0.93$$

$$2 - 12 \text{ KeVee} \rightarrow 4.5 - 27 \text{ KeVr}$$

CDMS-II in Soudan

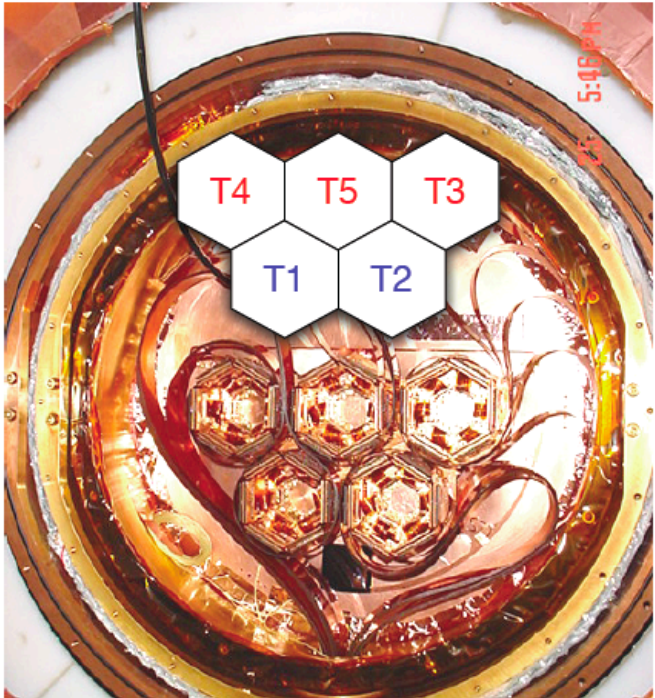

Plastic scintillator

detector cold volume ("icebox")

Oxford Instruments
400 μ W
dilution
refrigerator

RF shielded
class 10,000
clean room

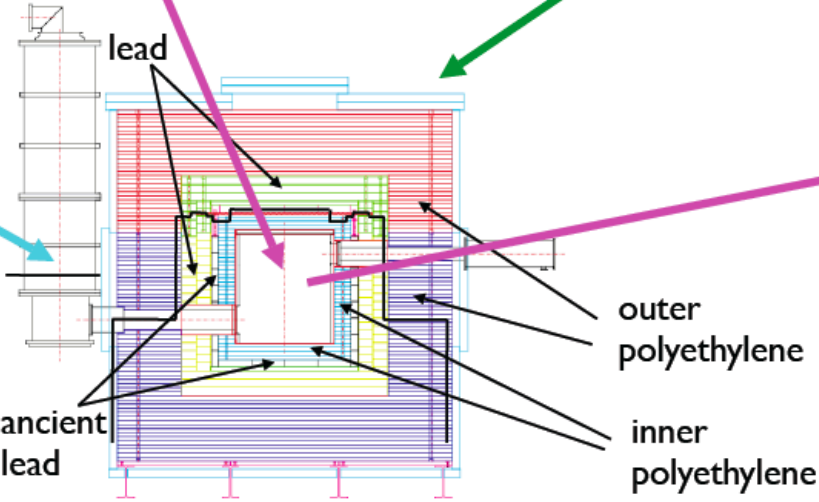

detectors operate @ 40 mK

CDMS-II New Results

194 kg-days exposure = 4.4 kg x 139 day x 0.33 (eff.)

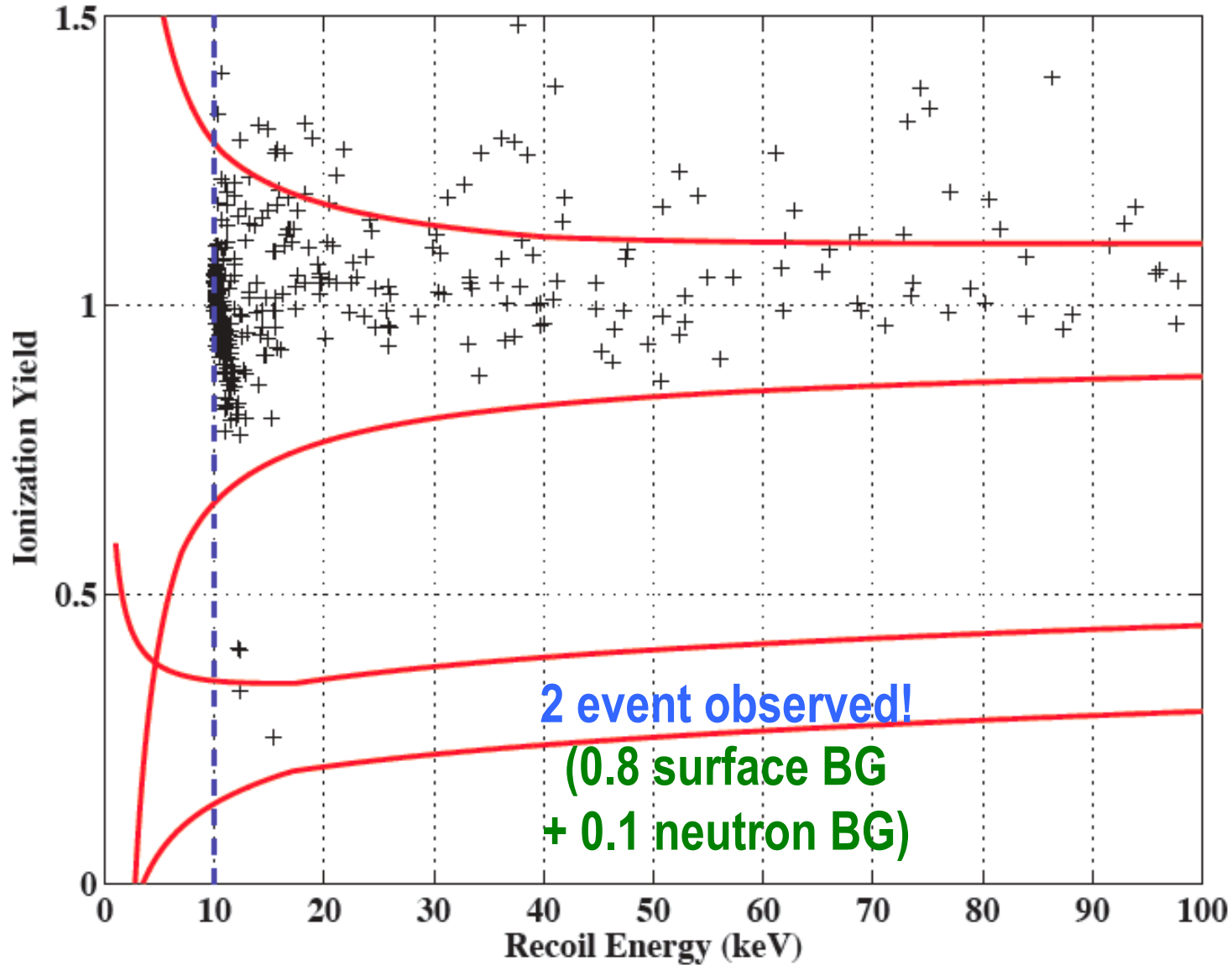

90% CL Limits of SI Cross Section

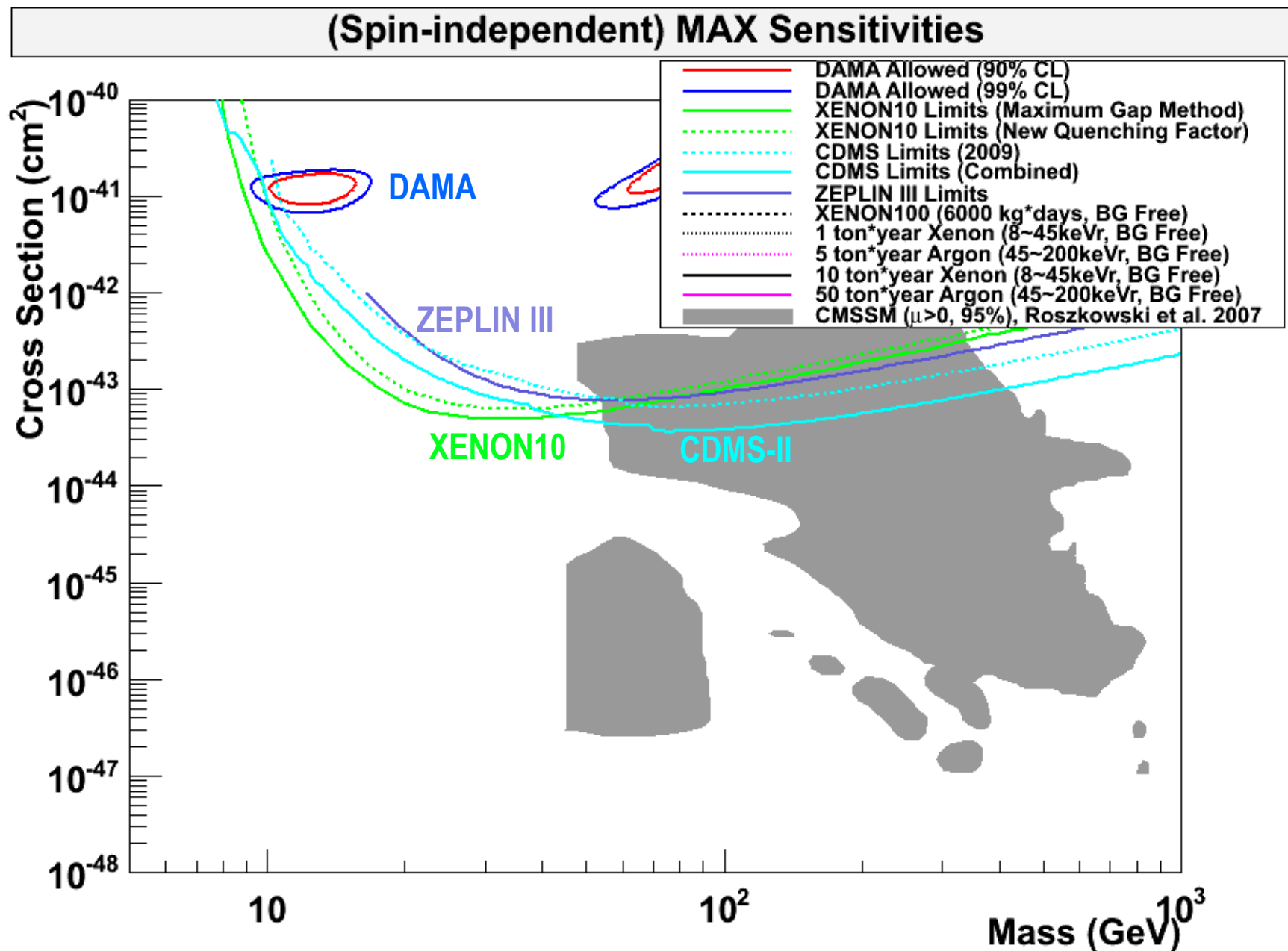

90% CL Limits of SI Cross Section

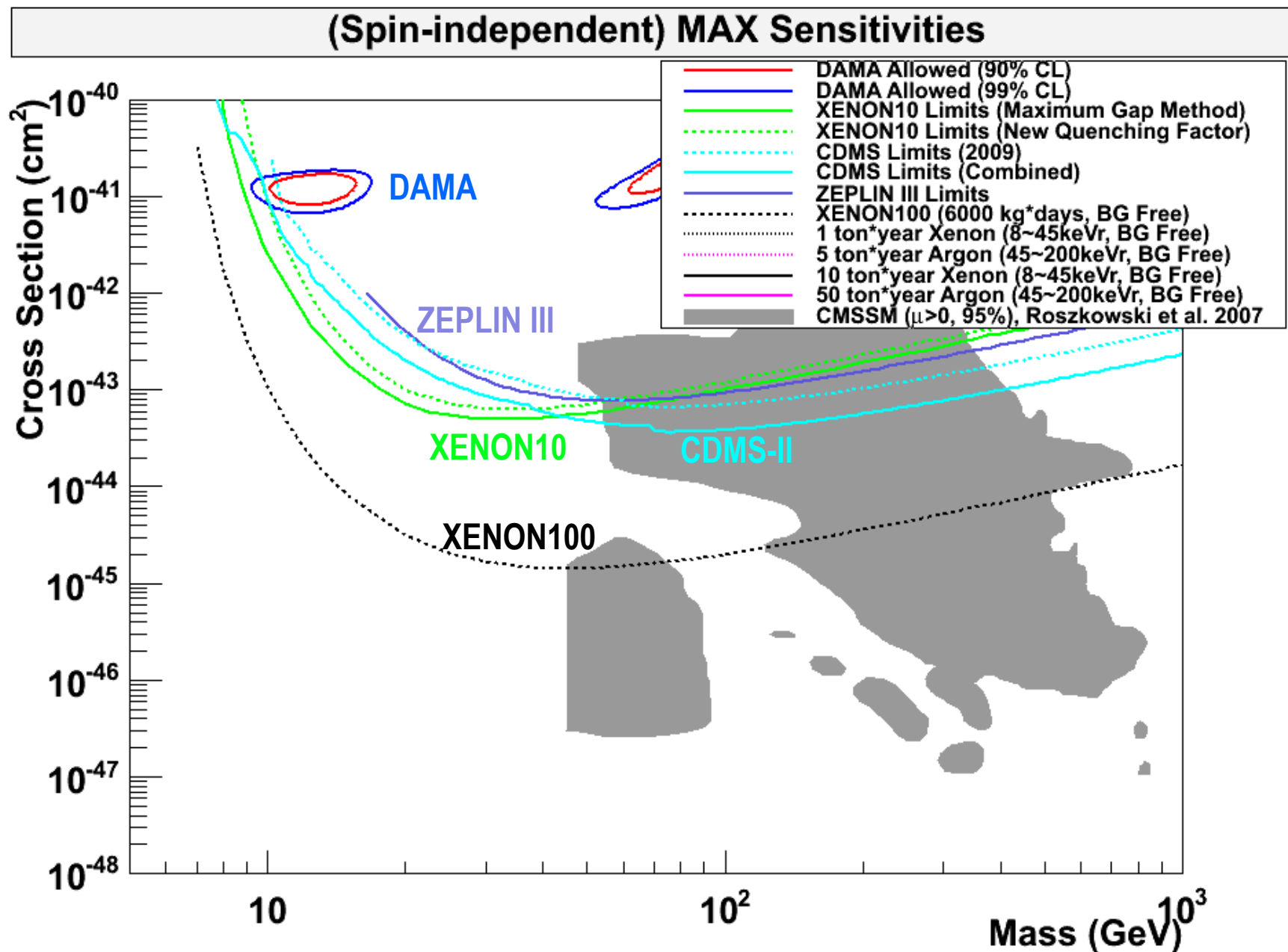

90% CL Limits of SI Cross Section

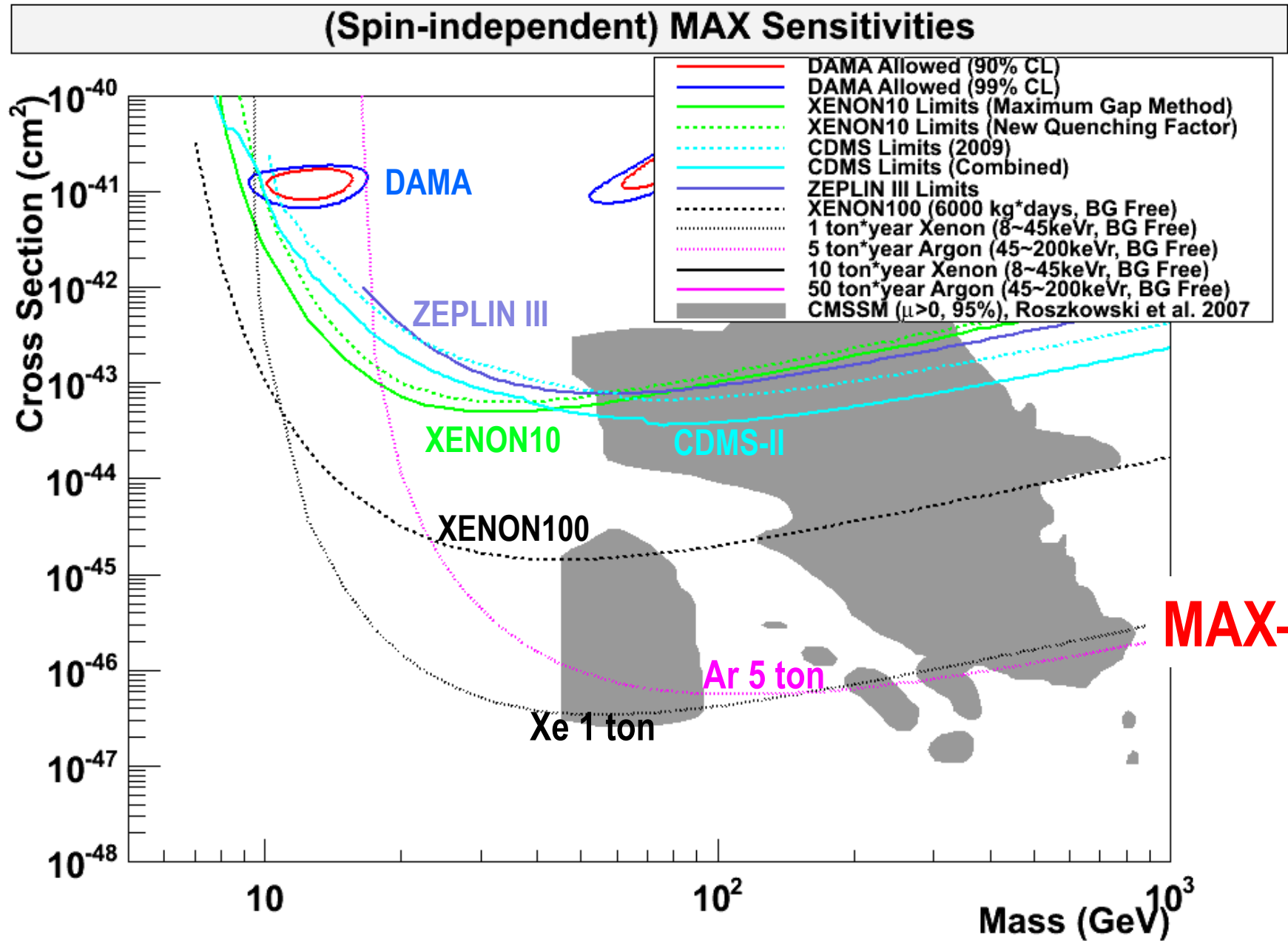

90% CL Limits of SI Cross Section

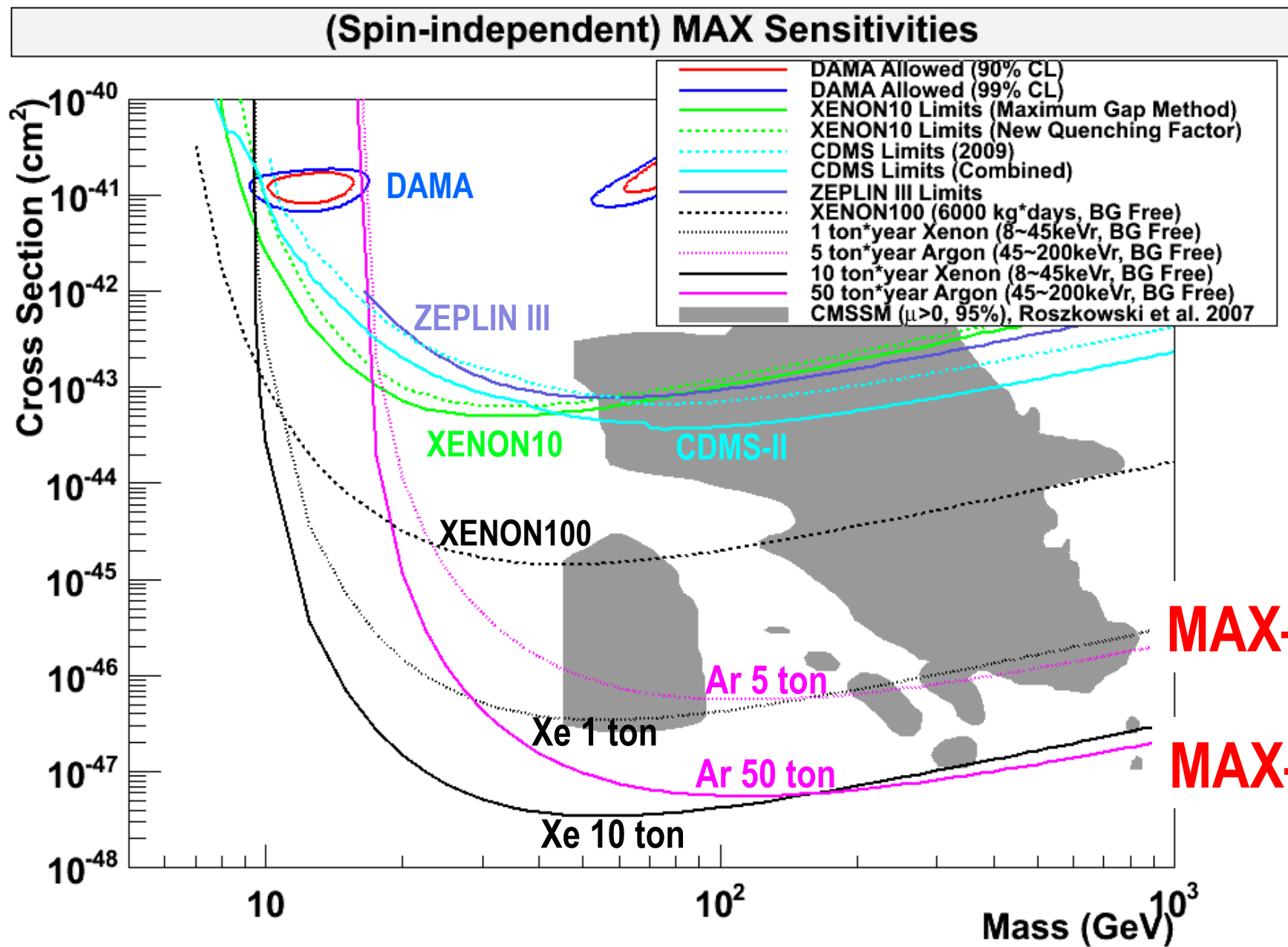

Comparison of Xenon Detector Size

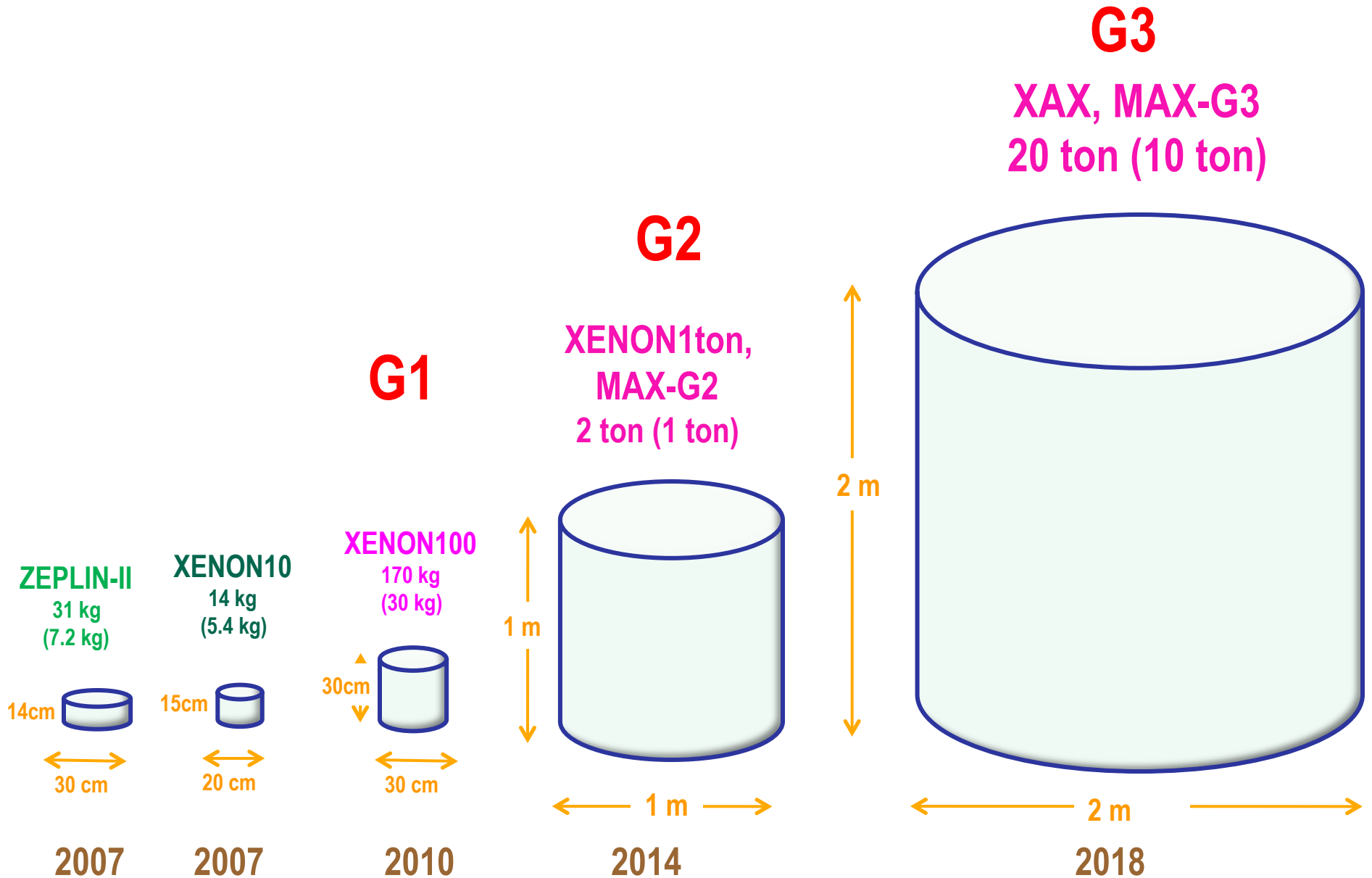

XENON100



XENON100 Collaboration

DOE + NSF



Katsushi Arisaka
David Cline
Hanguo Wang
UCLA

NSF



Elena Aprile
Columbia University

NSF



Uwe Oberlack
Rice University

Switzerland



Laura Baudis
University of Zurich

Portugal



Jose Matias Lopes
University of Coimbra

Italy



Francesco Arneodo
LNGS

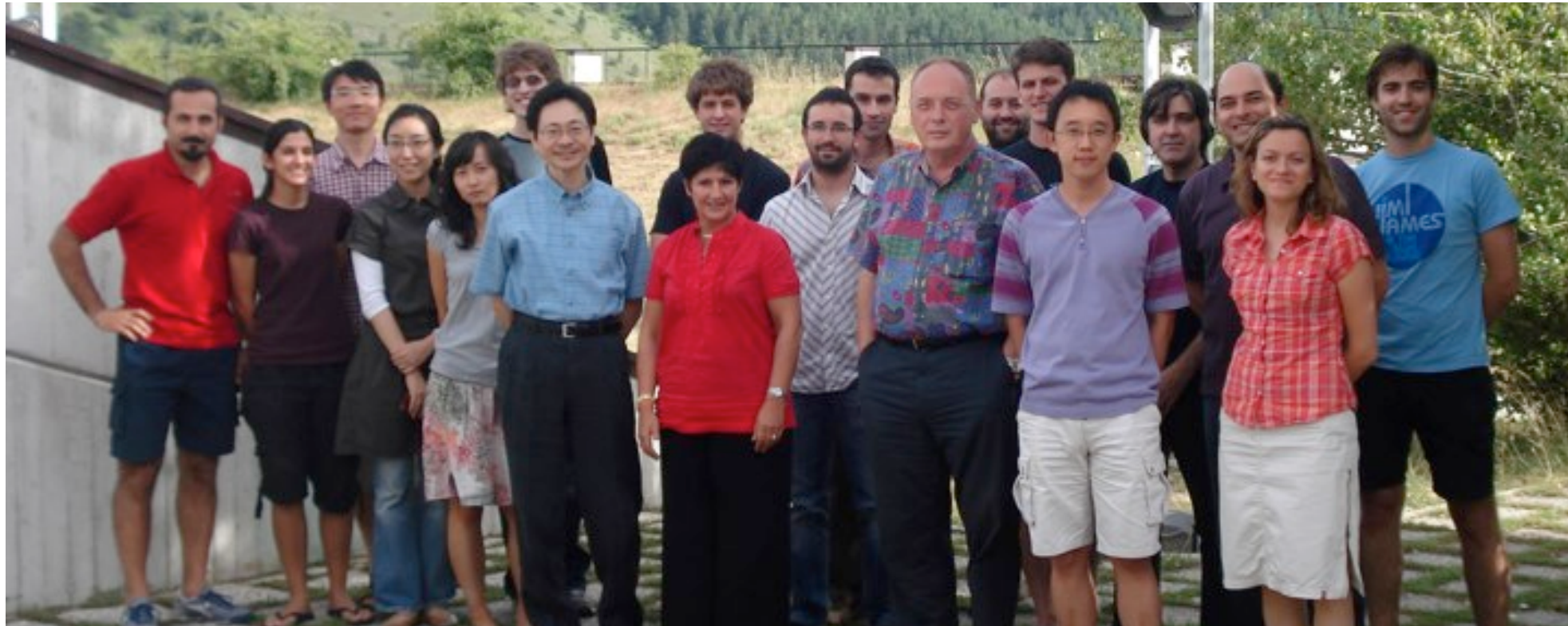

Laboratori Nazionali del Gran Sasso, Italy

LNGS 1400 m Rock (3100 w.m.e)



XENON100 Detector

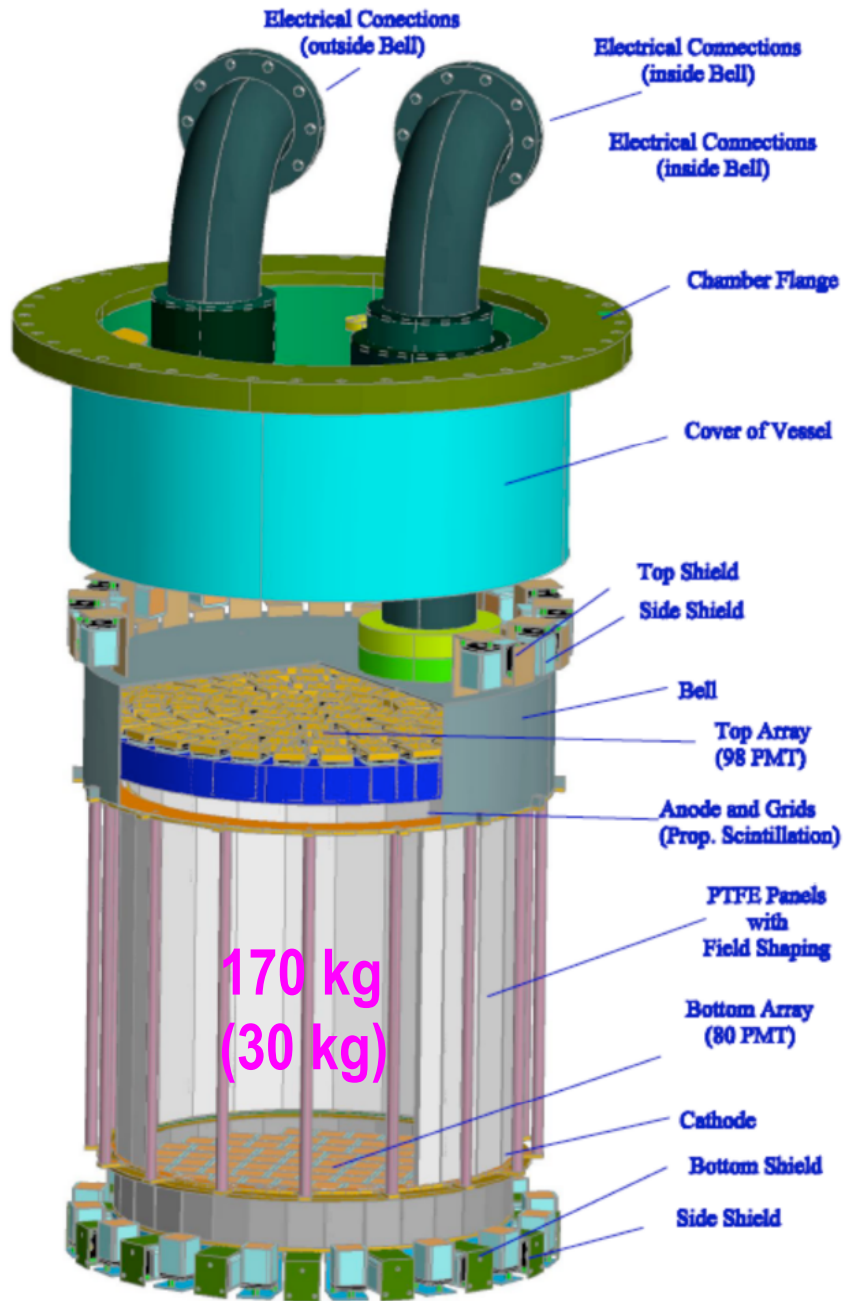

PMT Arrays

242 Hamamatsu R8520 PMTs

1"x1", optimized for response @ Xe scintillation light (175 nm)

Low radioactivity (~ <1 mBq/PMT)

Top Array

98 PMTs

~23% QE

Bottom Array

80 PMTs

~33% QE

Active Veto

64 PMTs

~23% QE

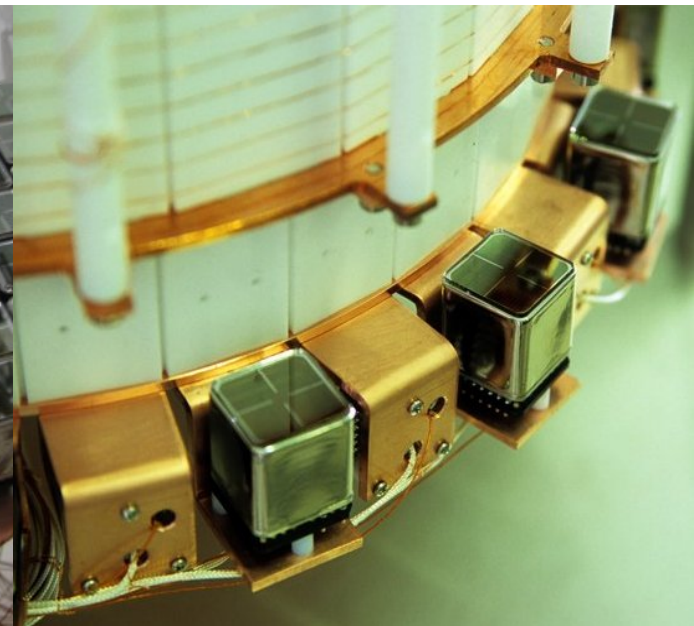
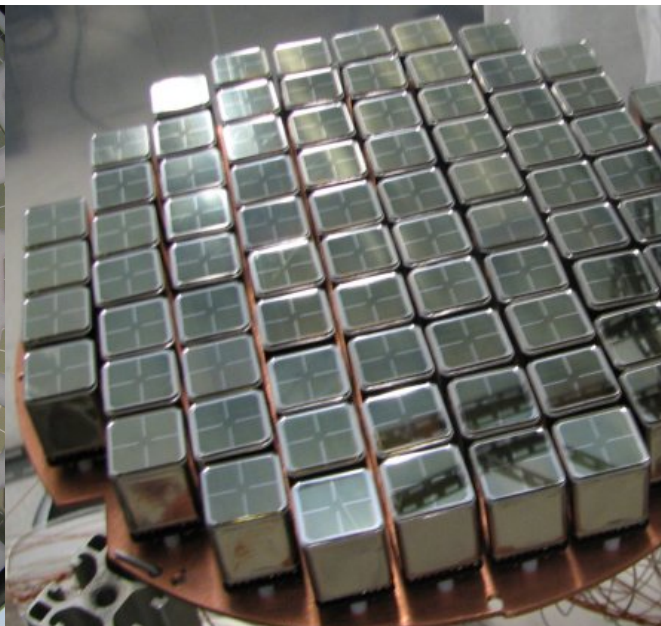
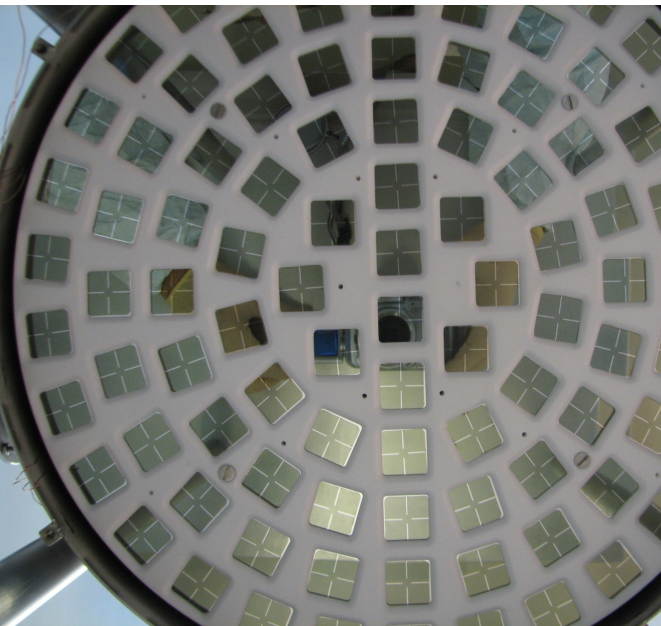

XENON100 Detector



XENON10 (2006 - 2007)



3/6/2010

Katsushi Arisaka, UCLA

XENON100 (2008 ~)



28

Pb
(20cm)

Poly
(20cm)

Cu
(5cm)

Cu
(5cm)

Poly
(20cm)

Pb
(20cm)

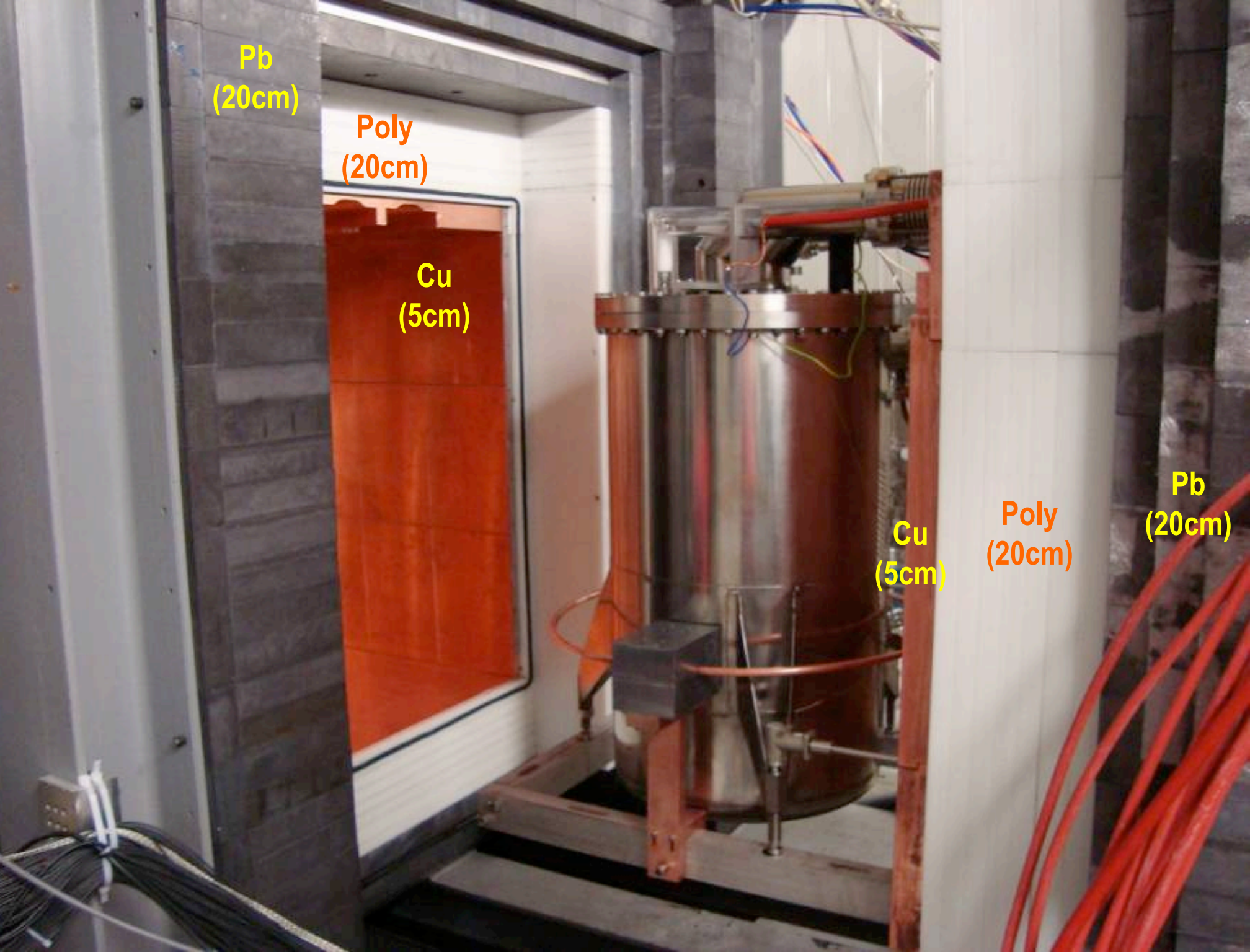

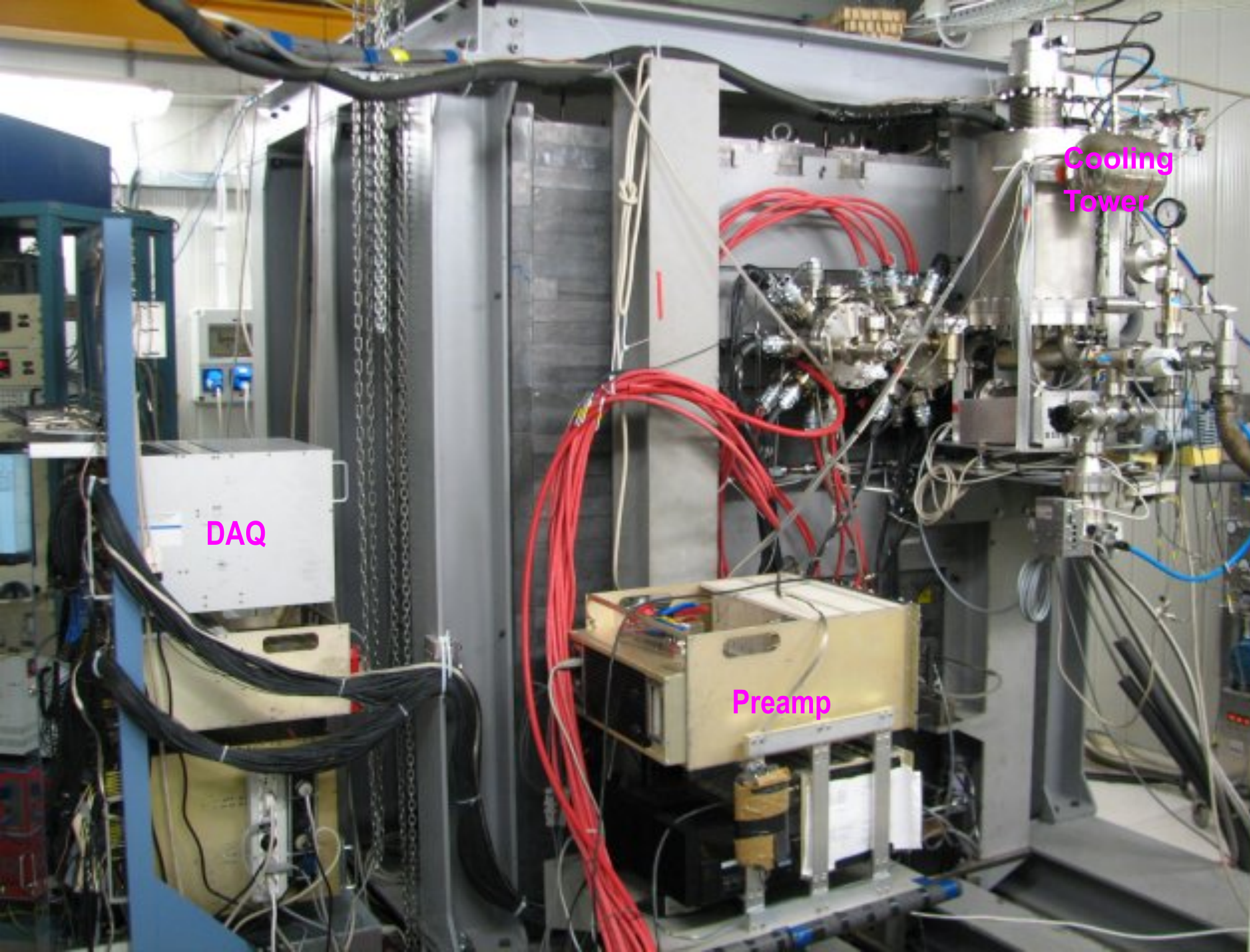

DAQ

Preamp

Cooling
Tower

A Typical Event

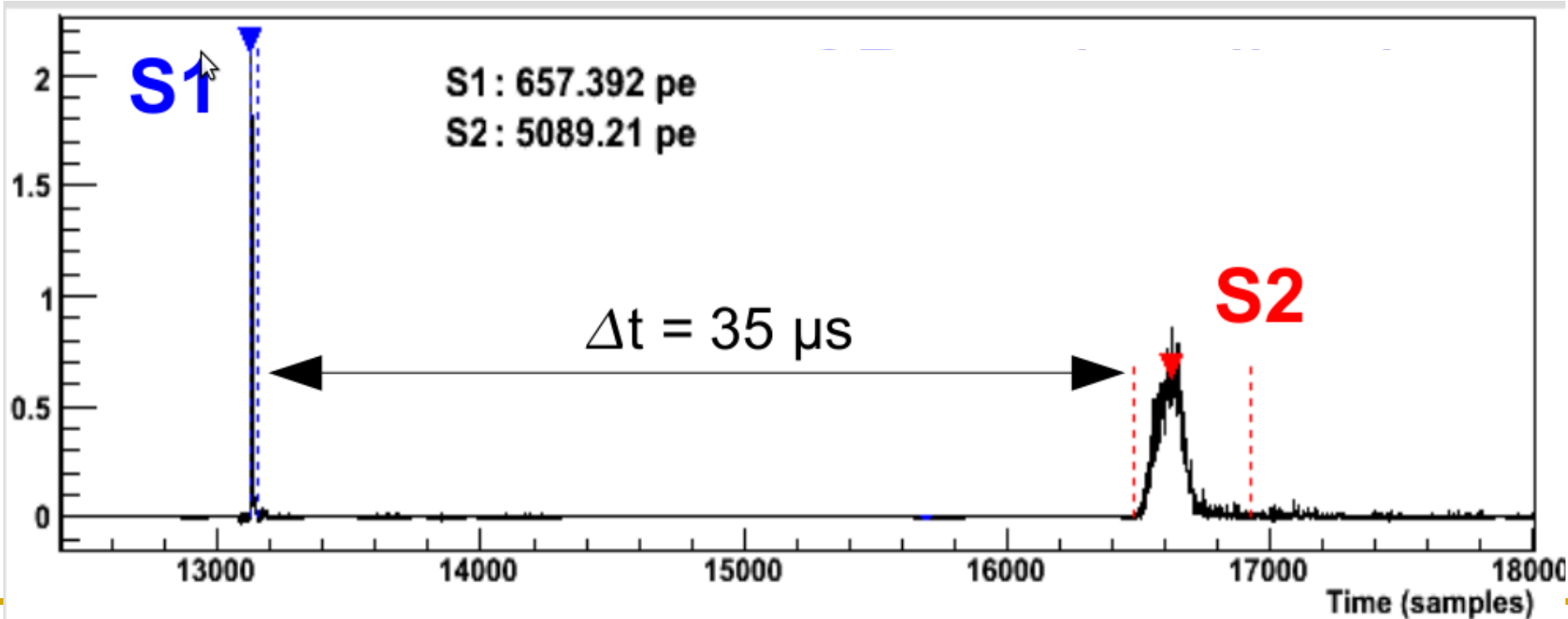
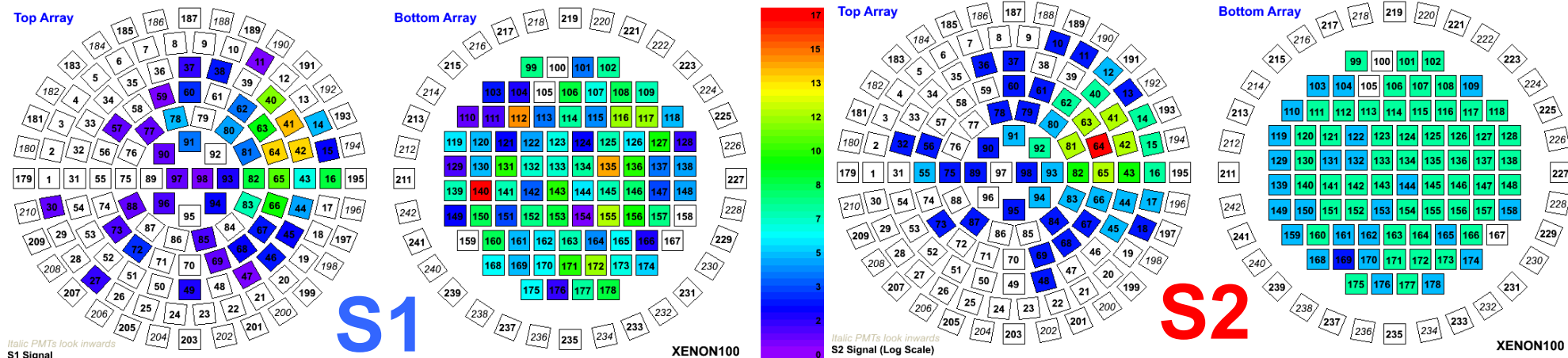

Electron Life Time

Cs137 Electron Lifetime Evolution (533 V/cm)

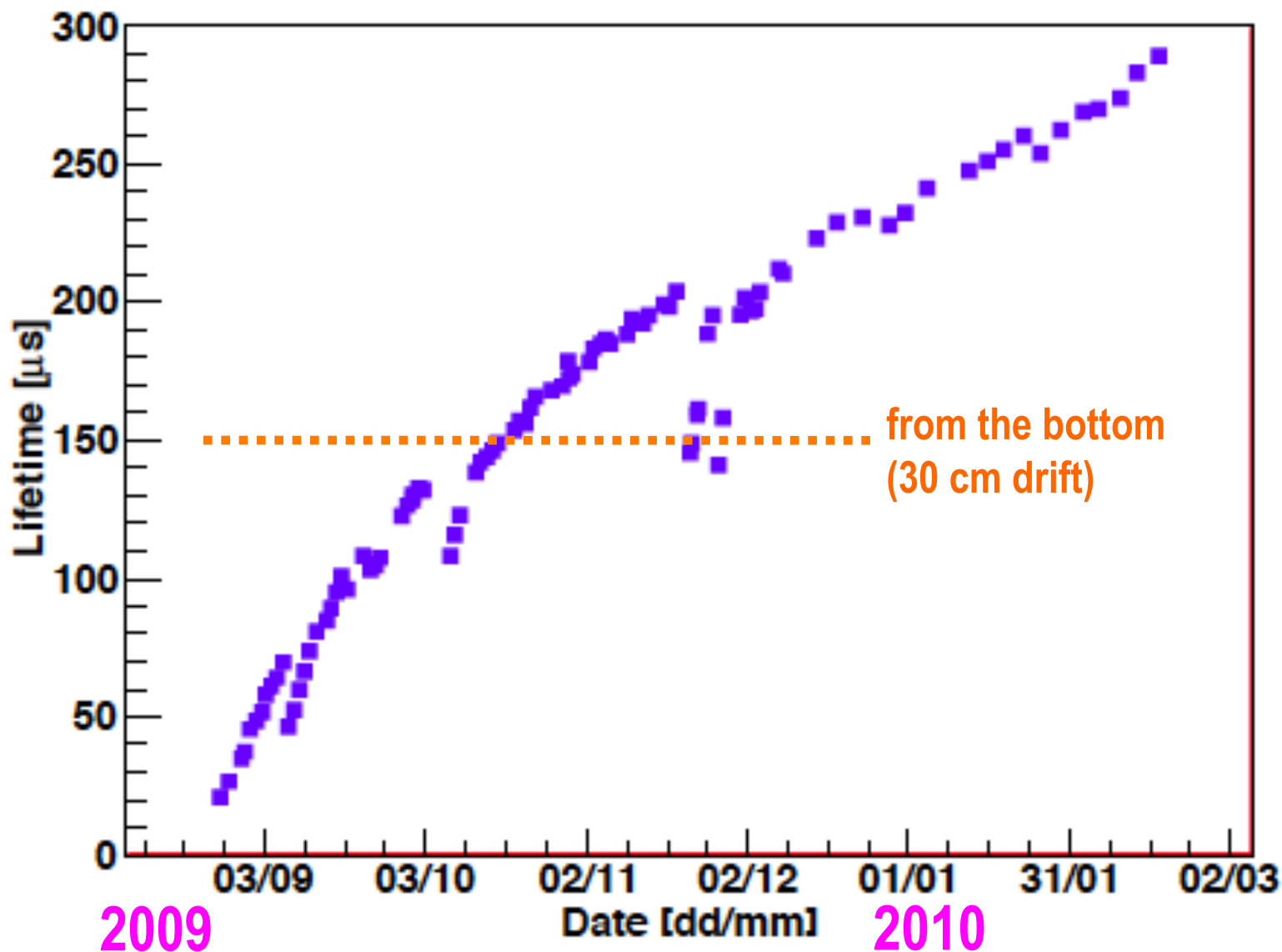

AmBe Neutron Band

AmBe Calibration of Neutron Band 30kg Fid.

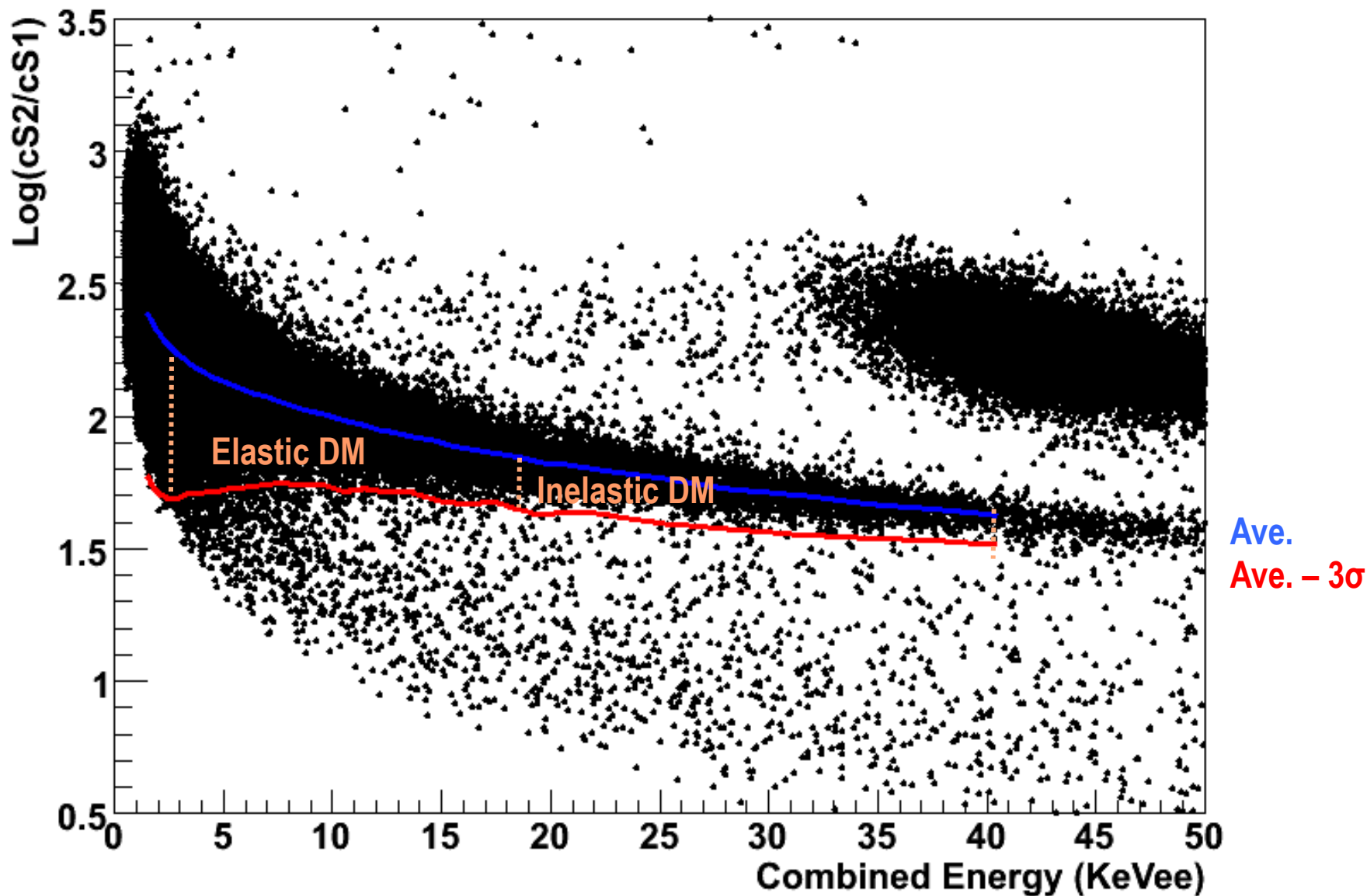

Co60 Gamma Band

Co60 Calibration of Gamma Band 30kg Fid.

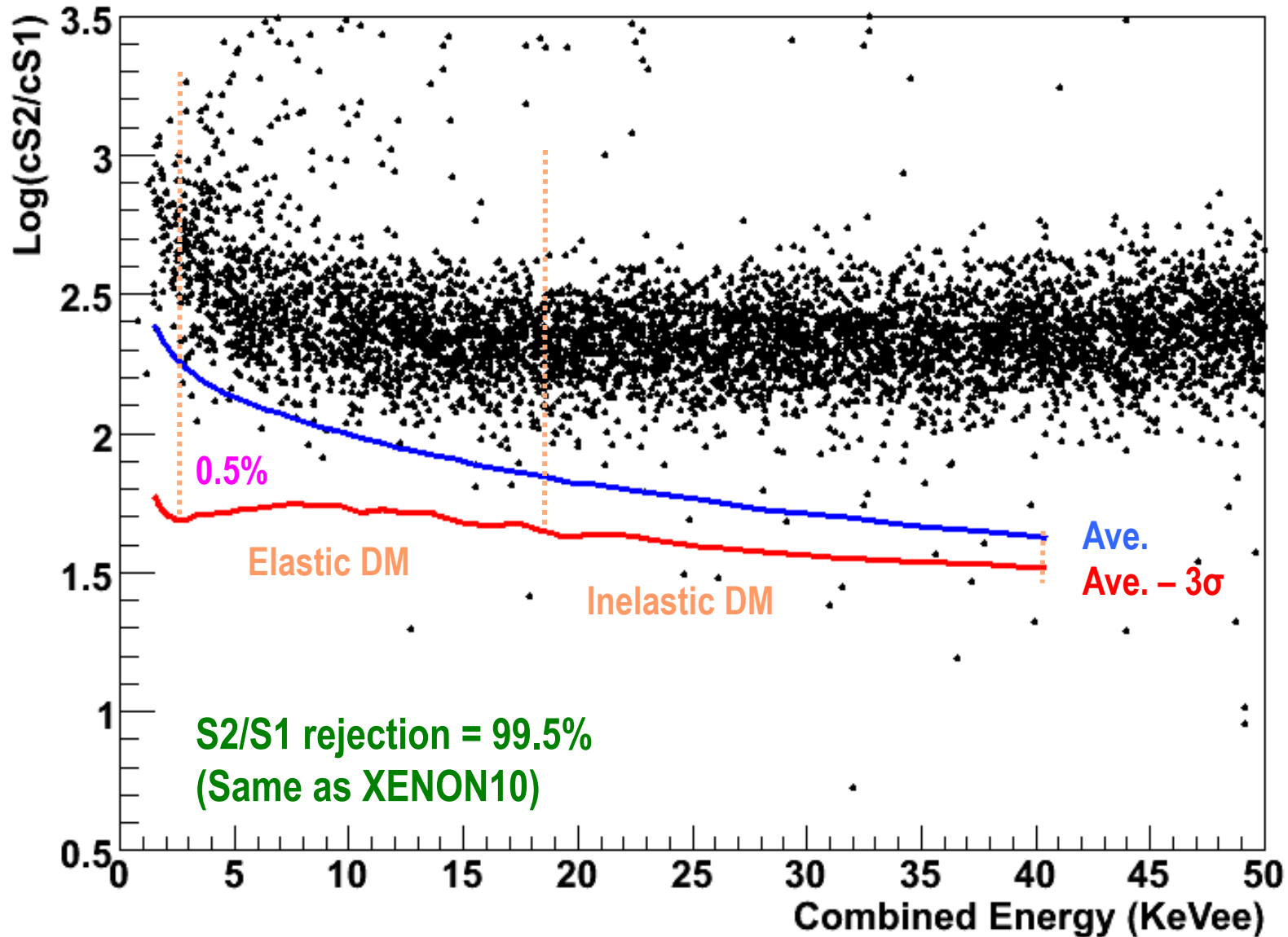

Status of XENON100

➤ Purity of Xenon has achieved the design goal.

	<u>Actual</u>	<u>Goal</u>	
▪ Light Yield:	3.2	> 3	pe/keV
▪ Electron Drift Time:	300 ↗	> 300	μs
▪ Krypton 85:	50 - 100	< 100	ppt
▪ Radon:	1.1 ± 0.4	< 2	Bq/m ³

➤ Serious calibration runs under way.

- Neutrons: AmBe
- Surface gammas: Co-60, Cs-137
- Internal gammas : Kr-83m (9 keV, 32 keV)

➤ Physics data taking started on January 15!

Energy Spectrum of Real Data vs. MC

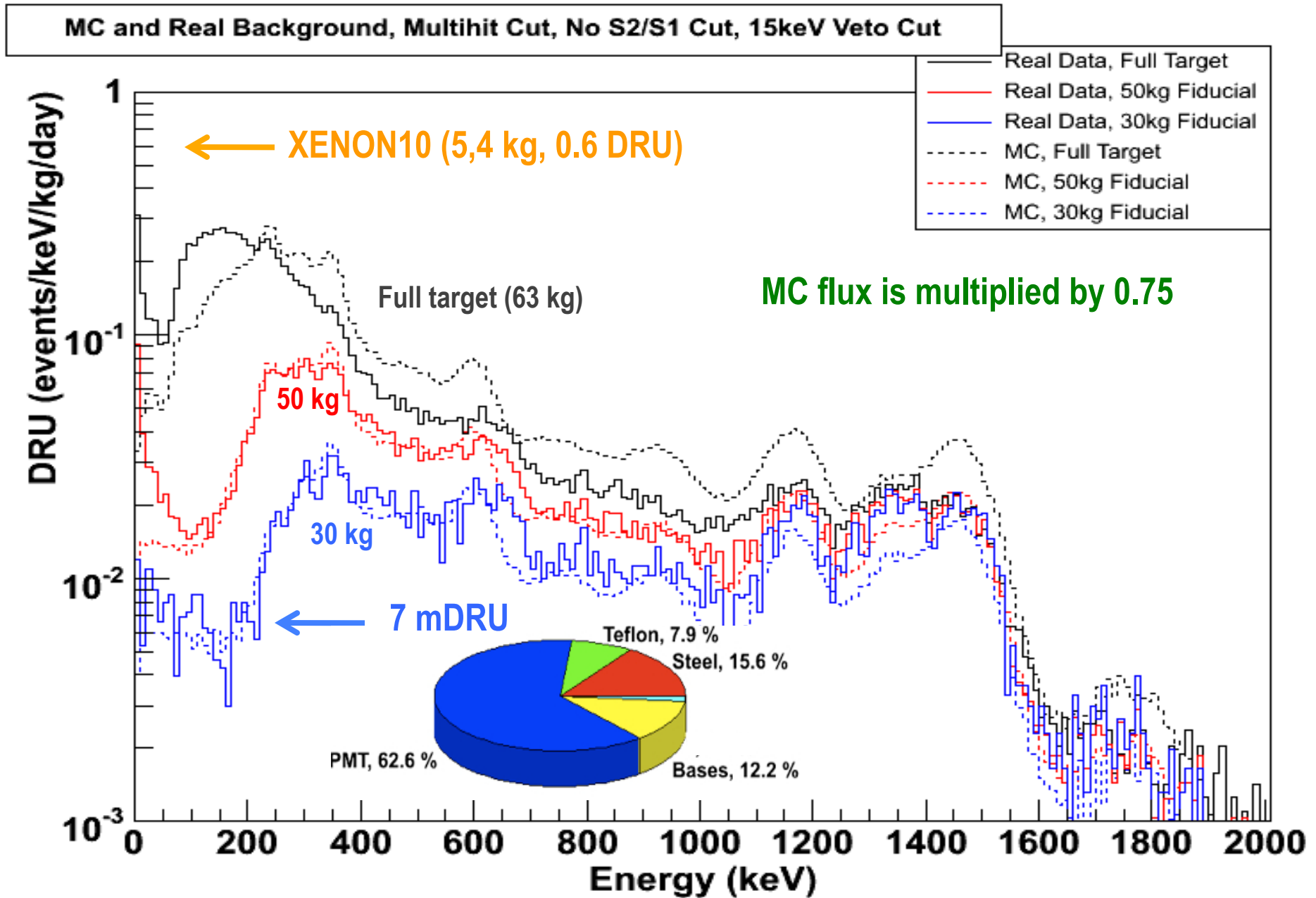

Z-R Distribution for Elastic Range before S2/S1 Cut

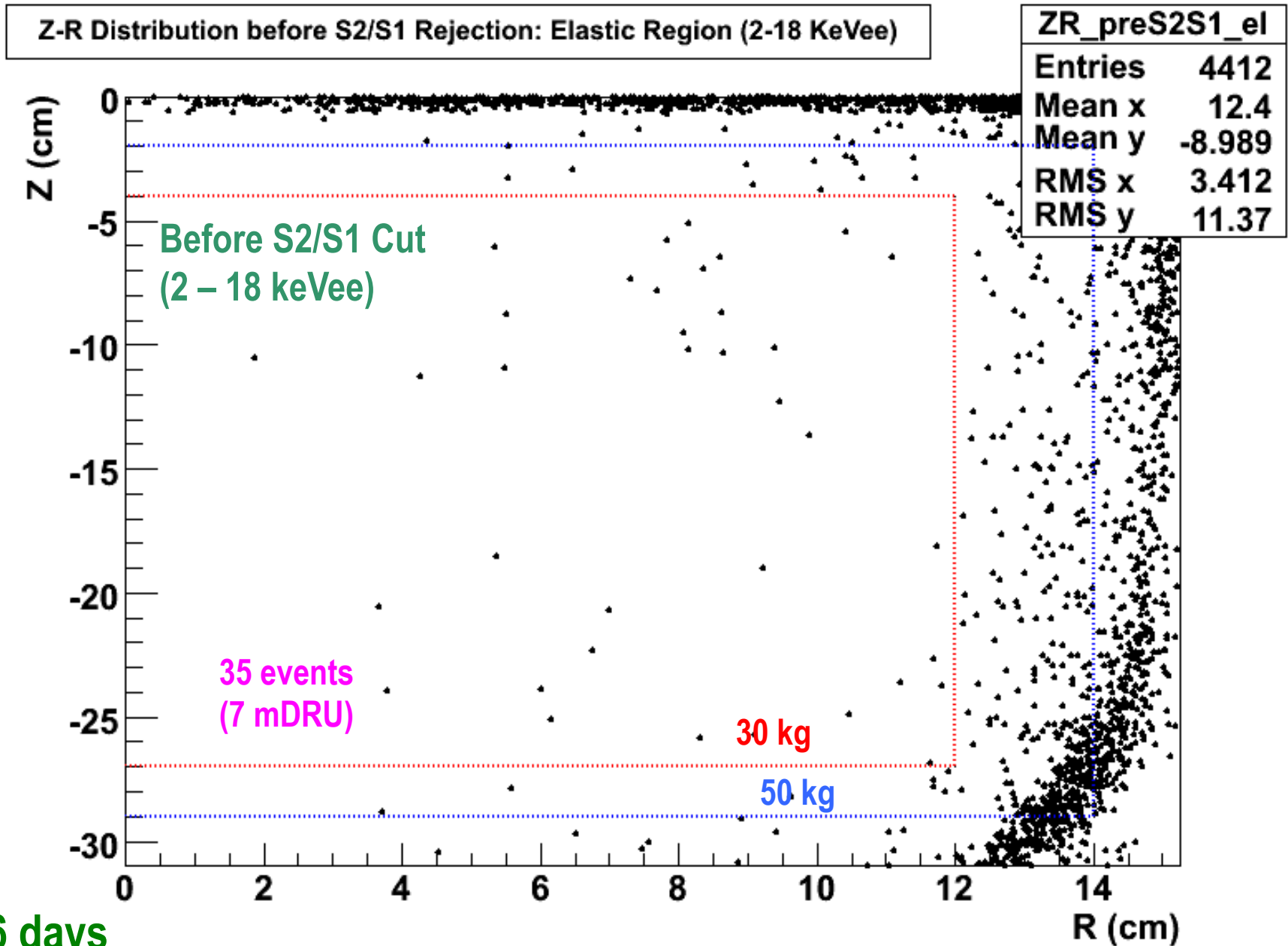

10.6 days

Z-R Distribution for Elastic Range after S2/S1 Cut

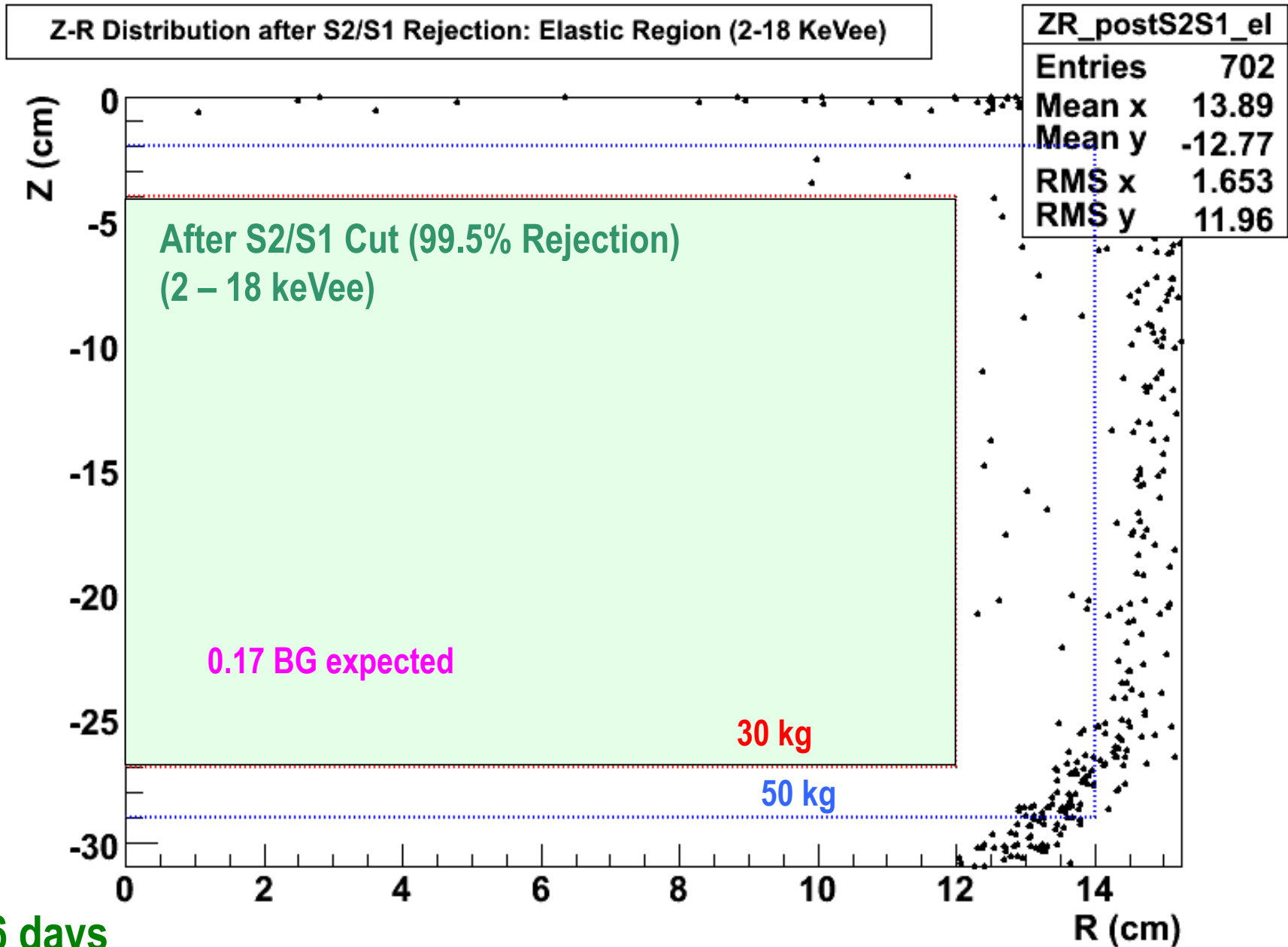

10.6 days

LogS2/S1 Real Data for 0-50 KeVee

Background Data after 30kg fid. cut, 300 kg-day

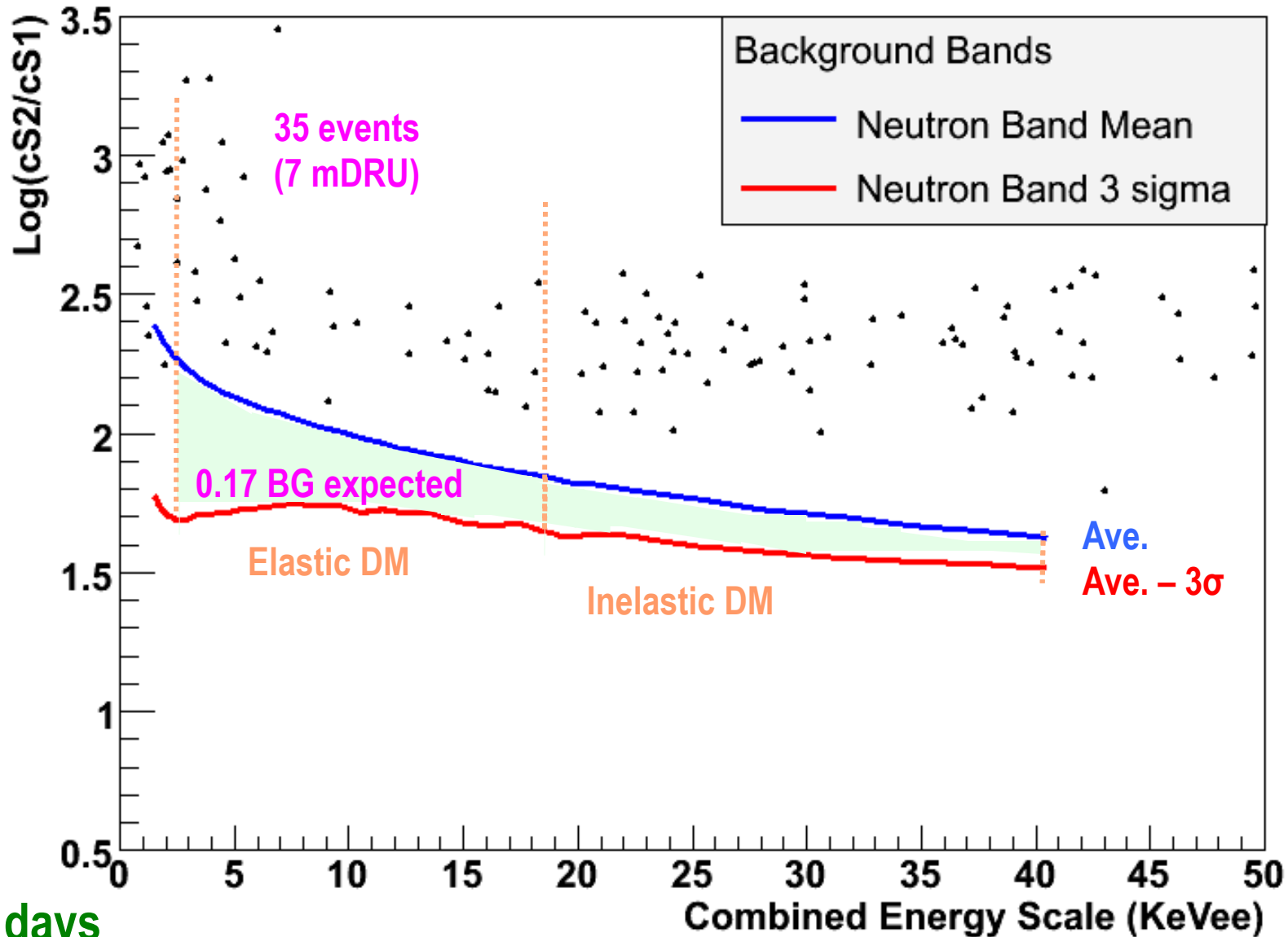

10.6 days

Comparison of CDMS, XENON10 and XENON100

	Fiducial Mass	Live days	Efficiency	Effective Exposure	Relative exposure (over CDMS-II)	No. of Observed Events	No. of Gamma BG (before S2/S1 cut)	No. of Gamma BG (before S2/S1 cut)	S2/S1 Rejection Efficiency	No. of Expected Gamma BG (after S2/S1 cut)
	kg	days		kg-days		Events	DRU	Events		Events
CDMS-II	4.4	139	0.317	194	1.00	2				0.80
XENON10	5.4	58.6	0.43	136	0.70	10	0.6	816	0.005	4.08
XENON100 (now)	30	10.6	0.4	127	0.65		0.007	35	0.005	0.17
XENON100 (Sept, 2010)	30	200	0.4	2400	12.4	?	0.007	700	0.005	3.5

90% CL Limits of SI Cross Section

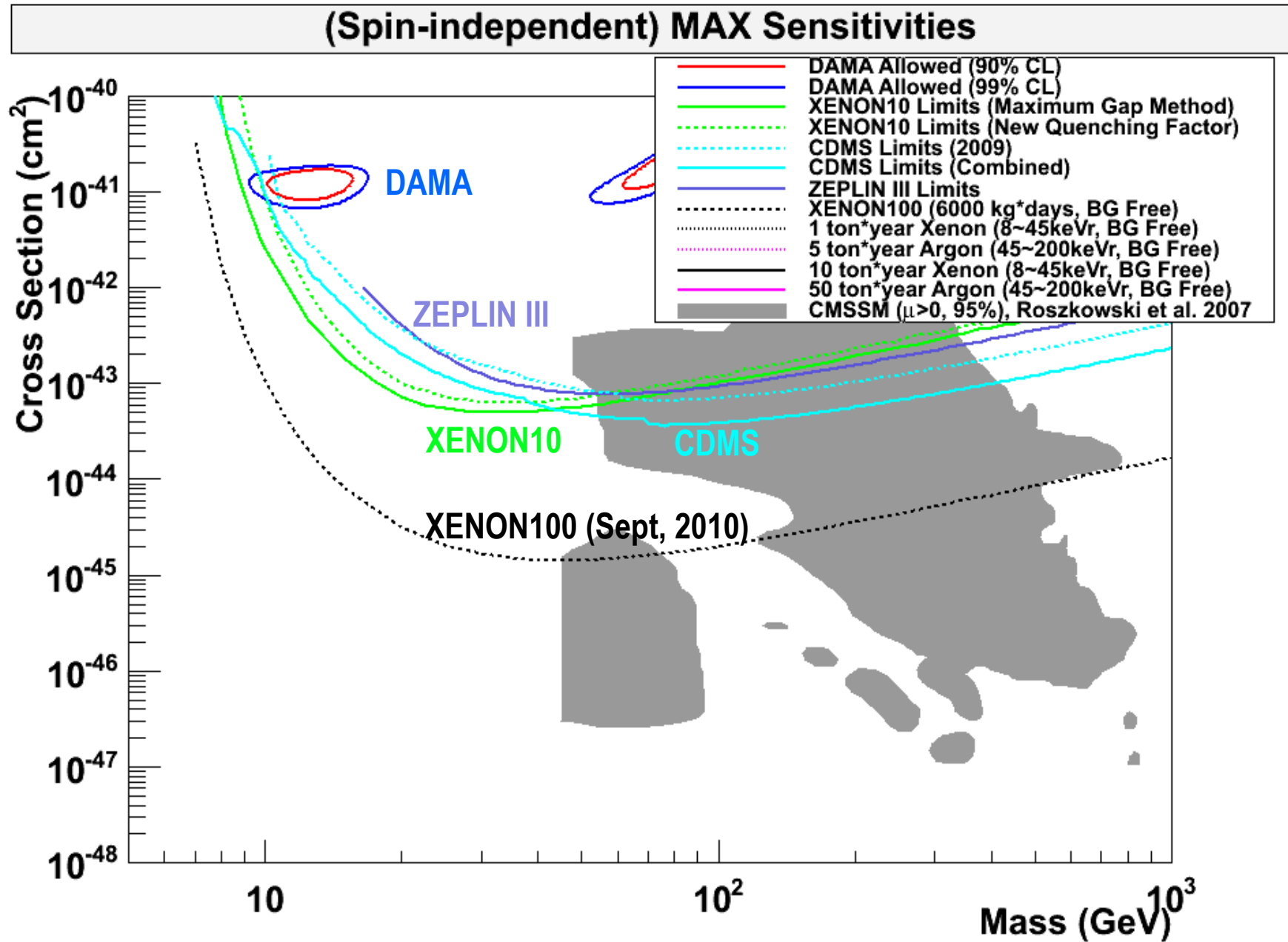

QUPID

Where backgrounds come from?

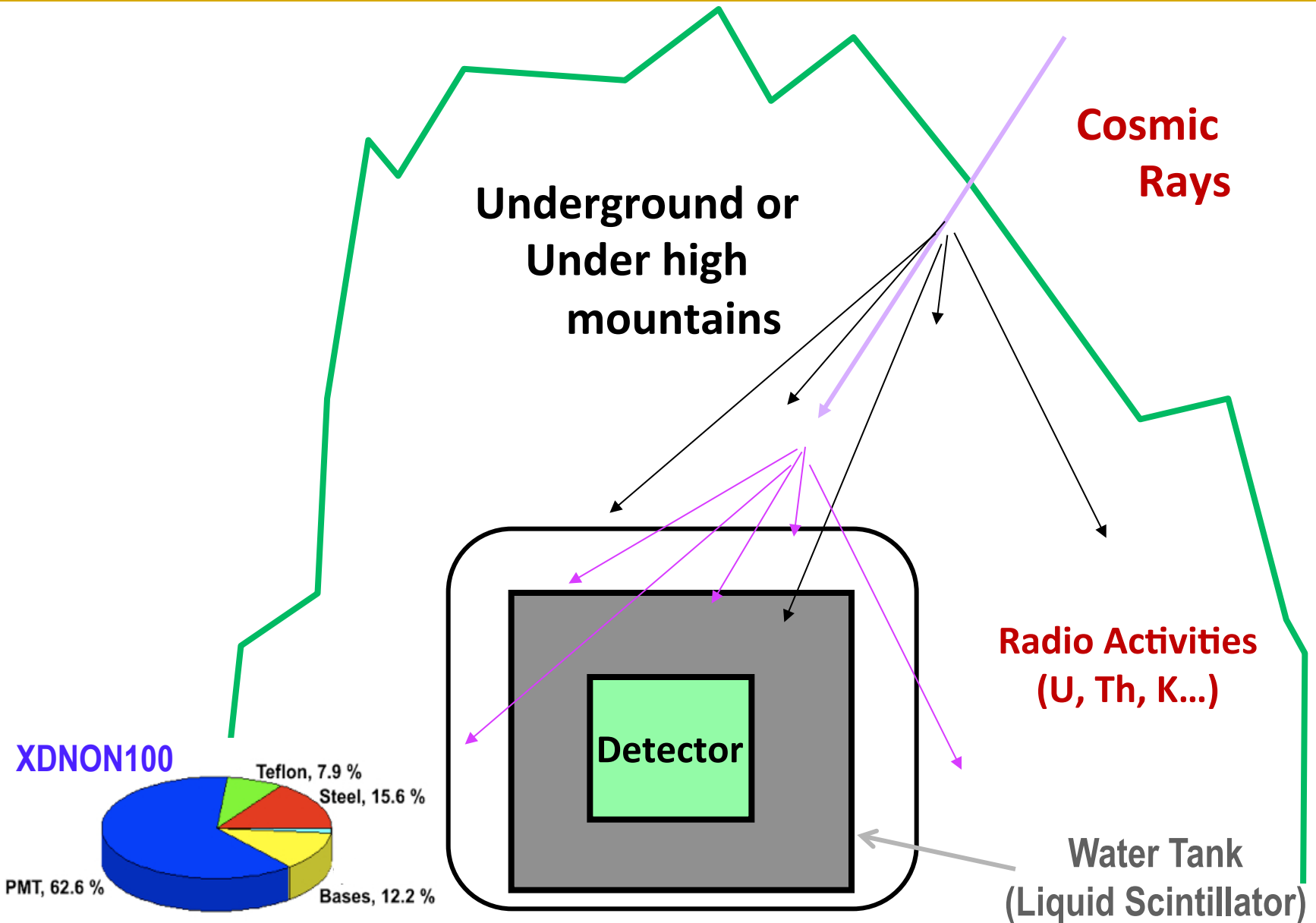

Photon detectors are the major source of backgrounds.

QUPID (QUartz Photon Intensifying Detector)

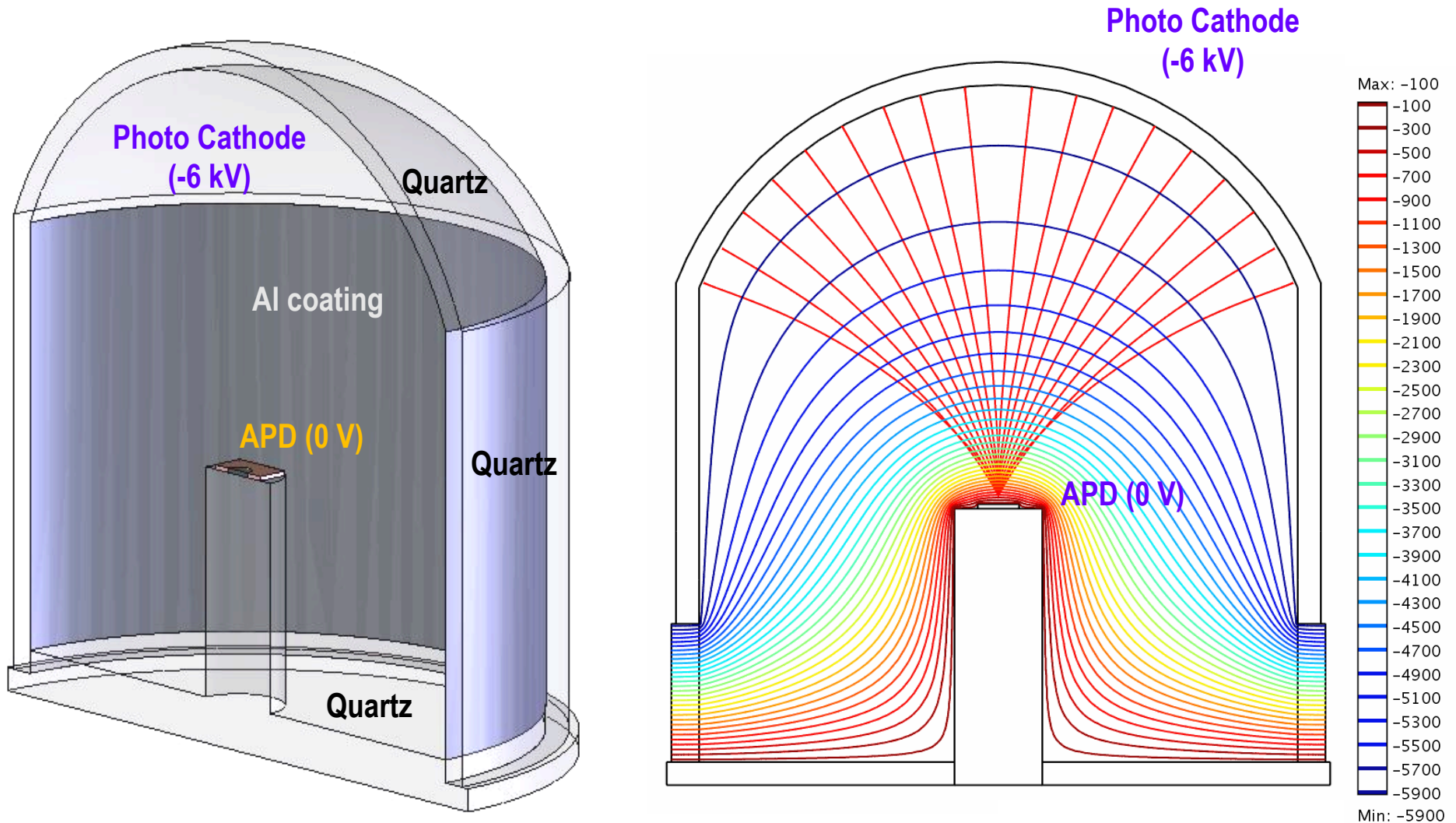

*Made by Synthetic Silica only.
US Patent (No. 5374826) pending.*

Comparison of Low-radioactive Photon Detectors from Hamamatsu

R8520
1 inch

R8778
2 inch

QUPID
3 inch

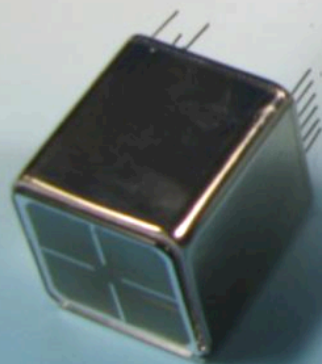

XENON10
XENON100

LUX
(XMASS)

XENON1Ton
DarkSide50
MAX 45

Spectrum of QUPIDs and Background (4 QUPIDs x 1 month data)

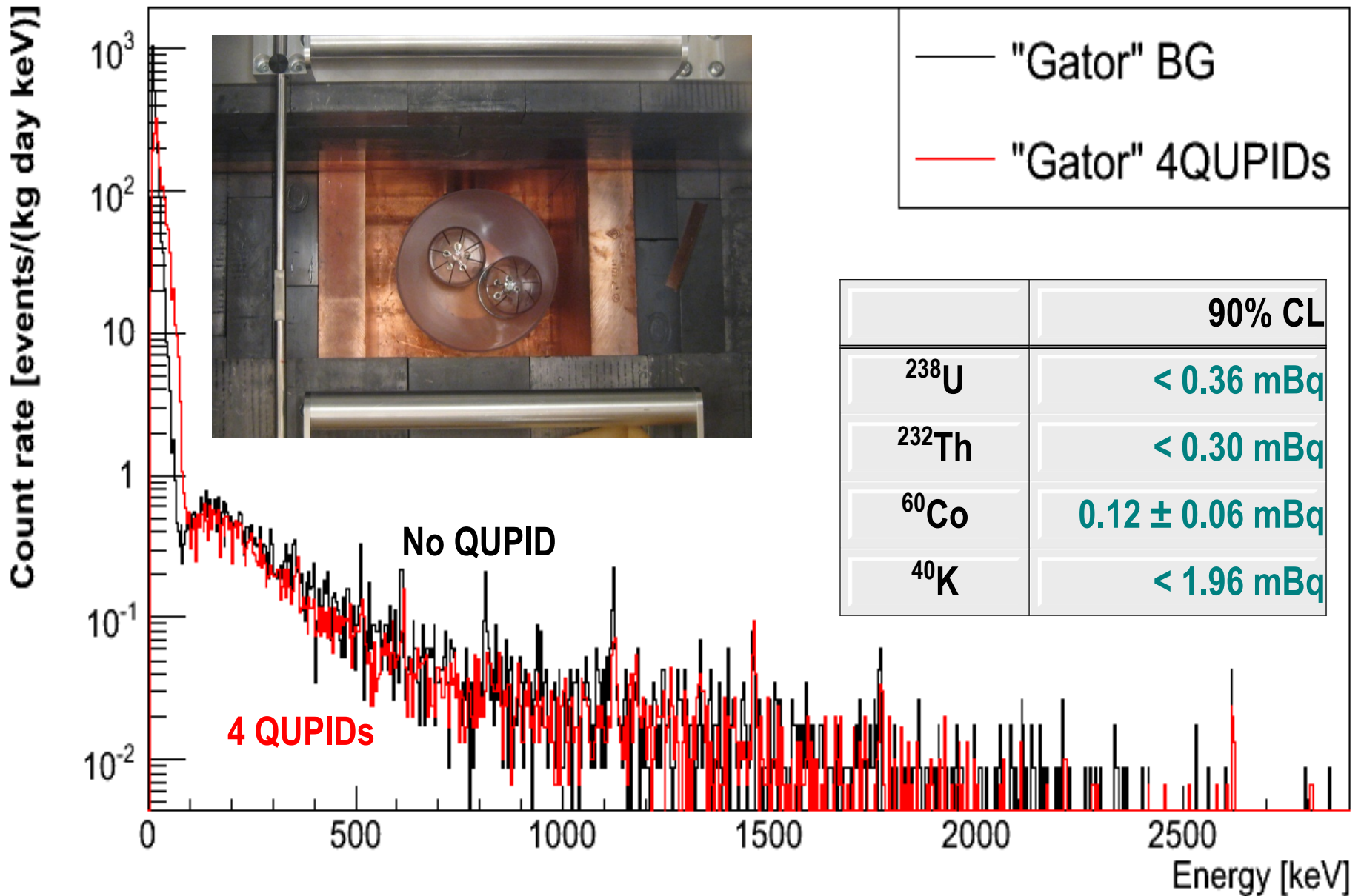

1, 2 and 3 PE Distribution with 2m cable

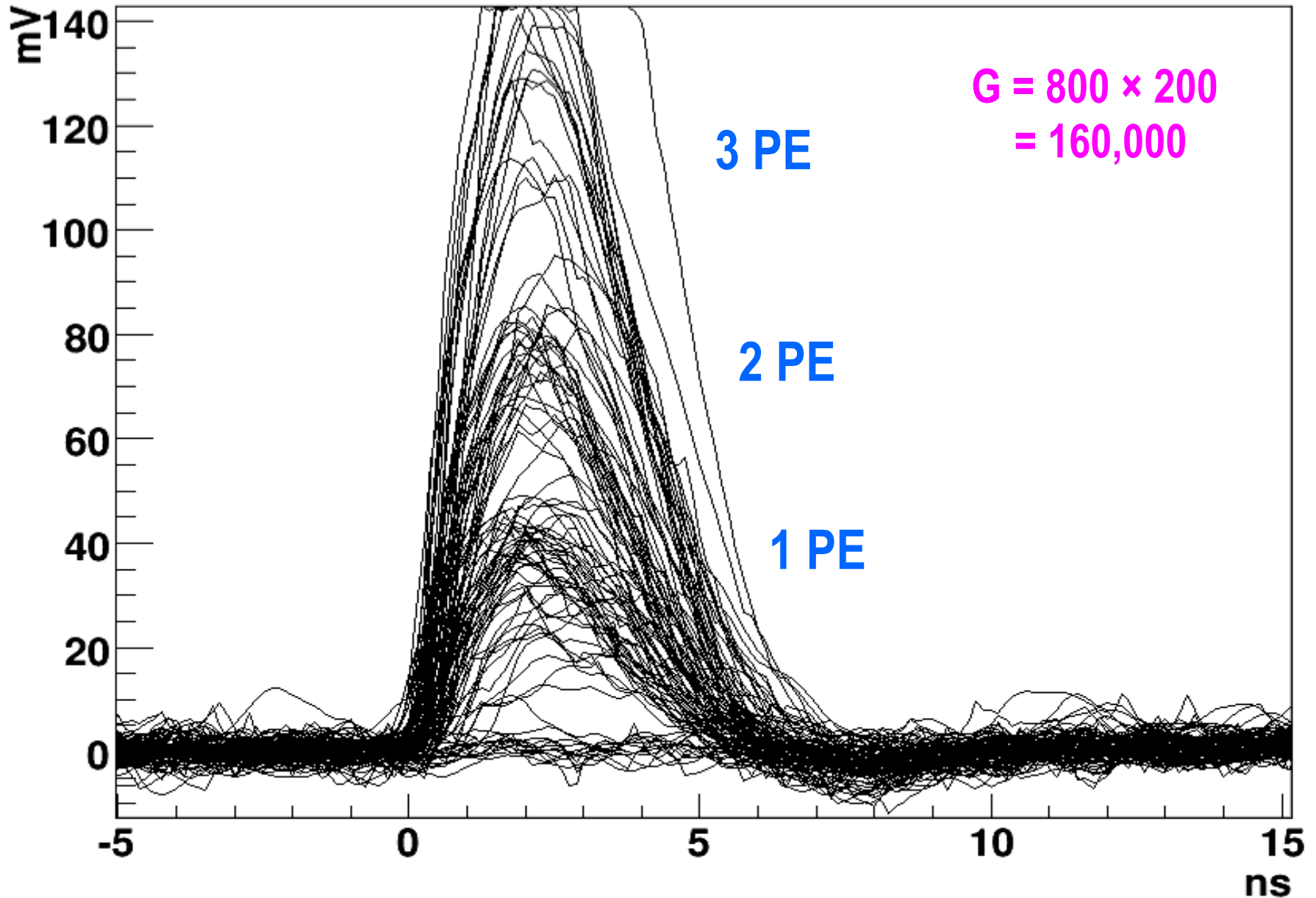

Summary of QUPID

- **Extremely low radioactivity:** < 1 mBq
 - < 0.1 neutron / year
 - << 10 times lower than conventional low radioactive PMTs.
- **Large diameter:** 3 inch
 - 6 inch is also under investigation.
- **Special Photocathode:** Bialkali LT
 - > 30 % QE at 170 – 450 nm
 - Low resistivity even at Liquid Ar temperature (- 185 °C)
- **True photon counting.**
 - 1, 2, 3... photoelectron peaks clearly visible.
 - 100% collection efficiency.
- **Simple HV supply.**
 - Common HV (-6 kV) for all QUPIDs
 - Resister chain not necessary
- **The first successful operation in Liquid Xenon at UCLA!**

New 3" QUPID (Production Version)



Cryogenic System at UCLA (Hanguo Wang's Lab)

Nitrogen

Liquid Xe

Artin Teymourian

QUPID in the Cooling System

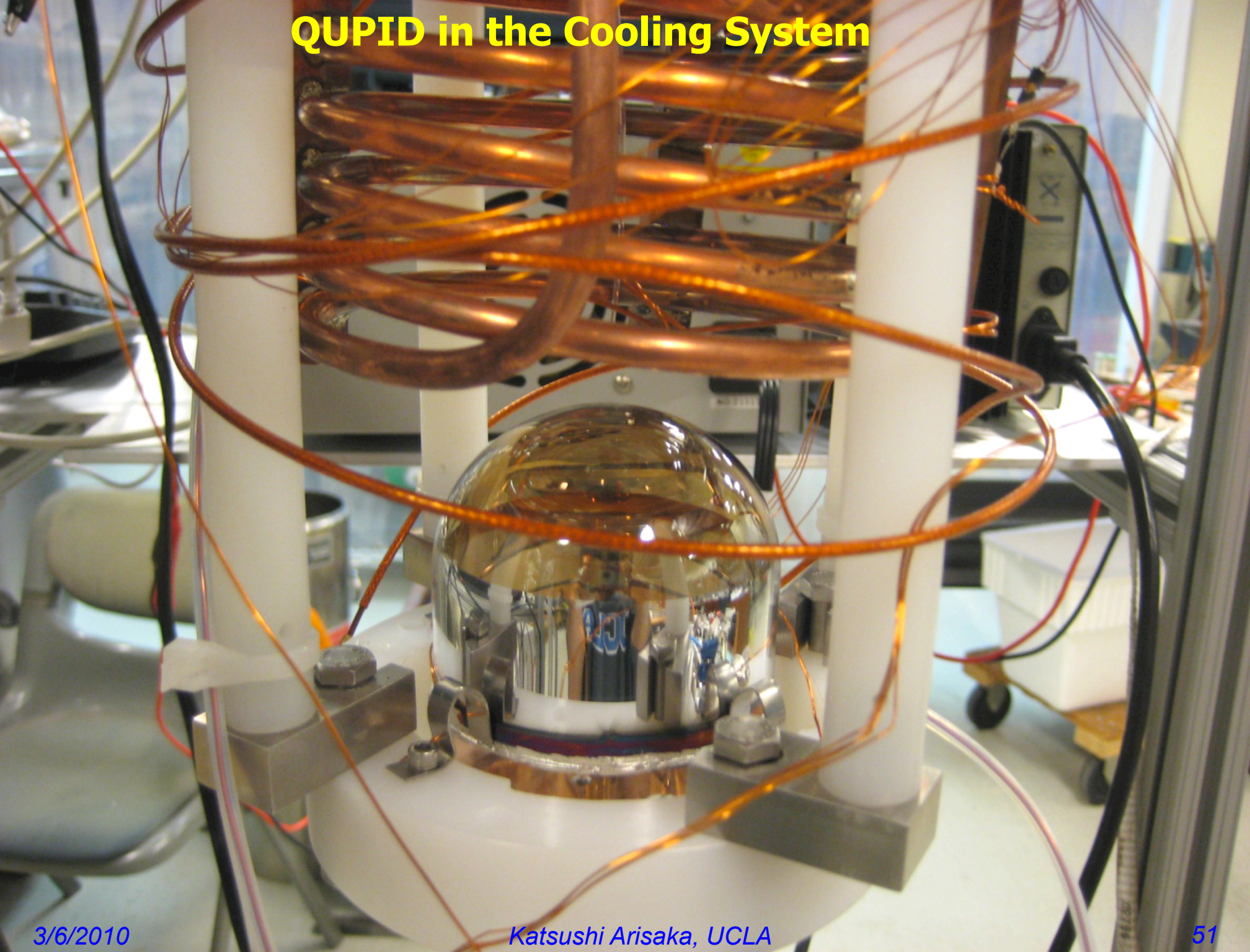

Electron Bombardment Gain (QHA26)

QHA26 Bombardment Gain Test, Various Temperatures

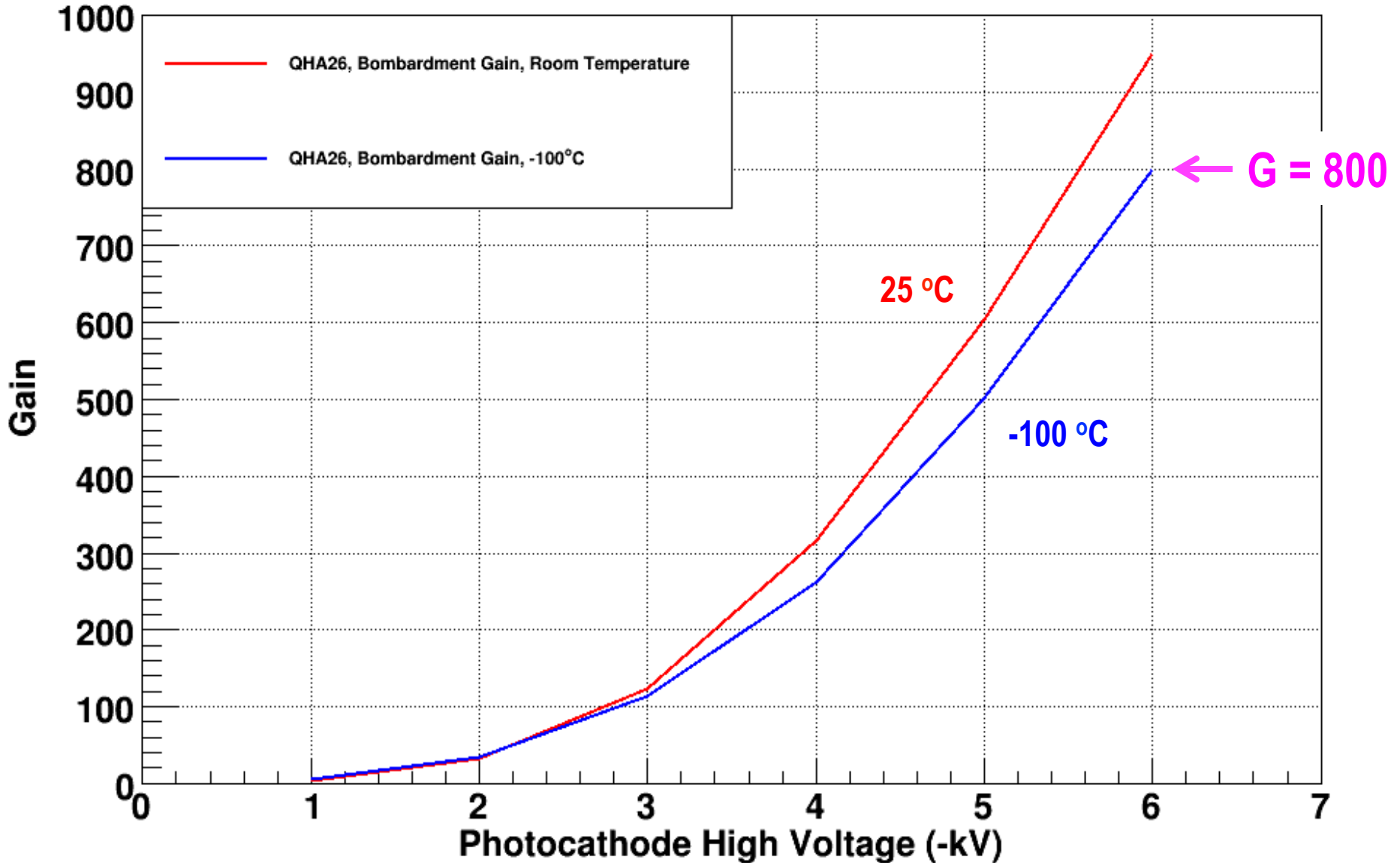

APD Gain and Leakage (QHA26)

QHA26 Avalanche Gain and Leakage Current

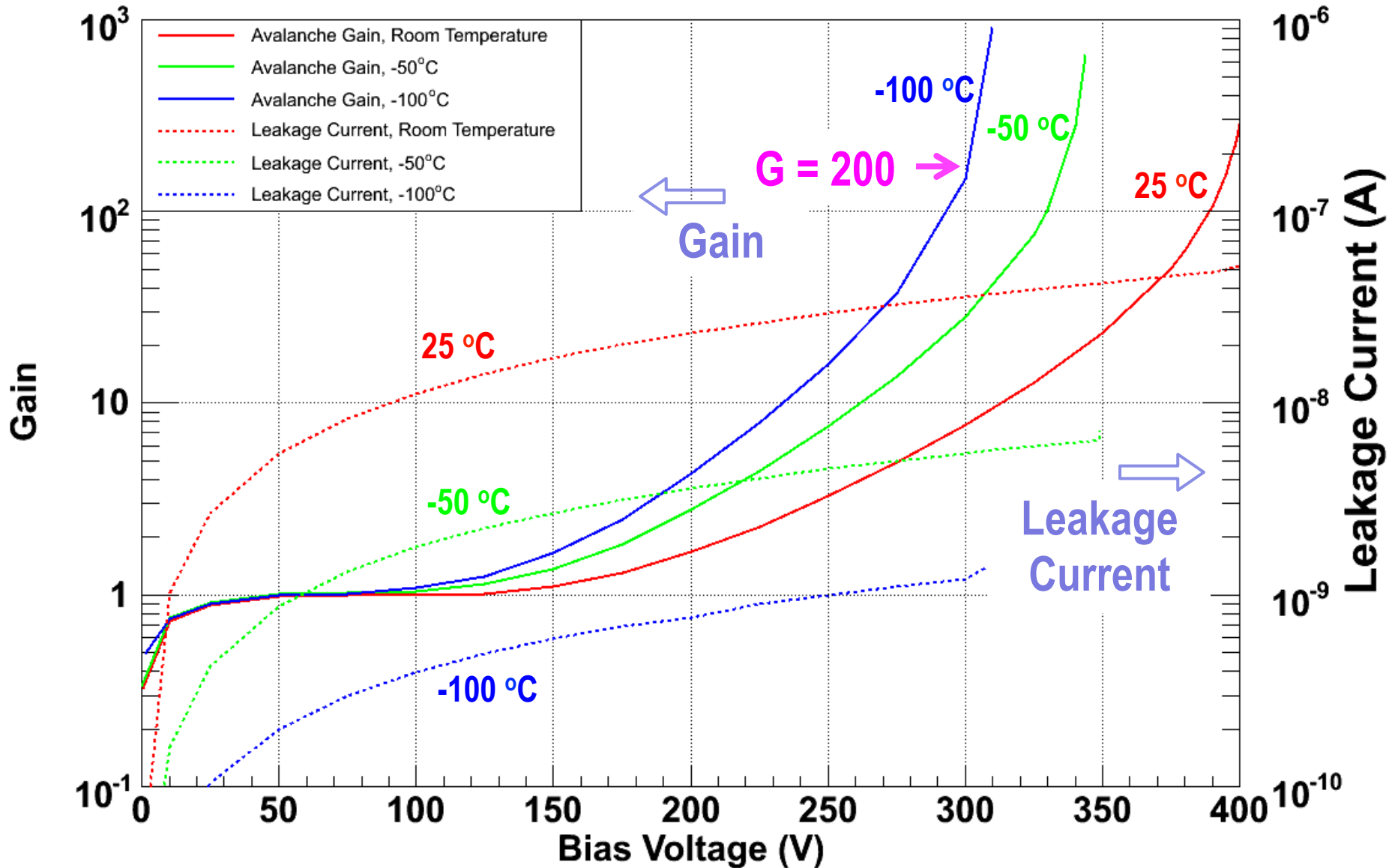

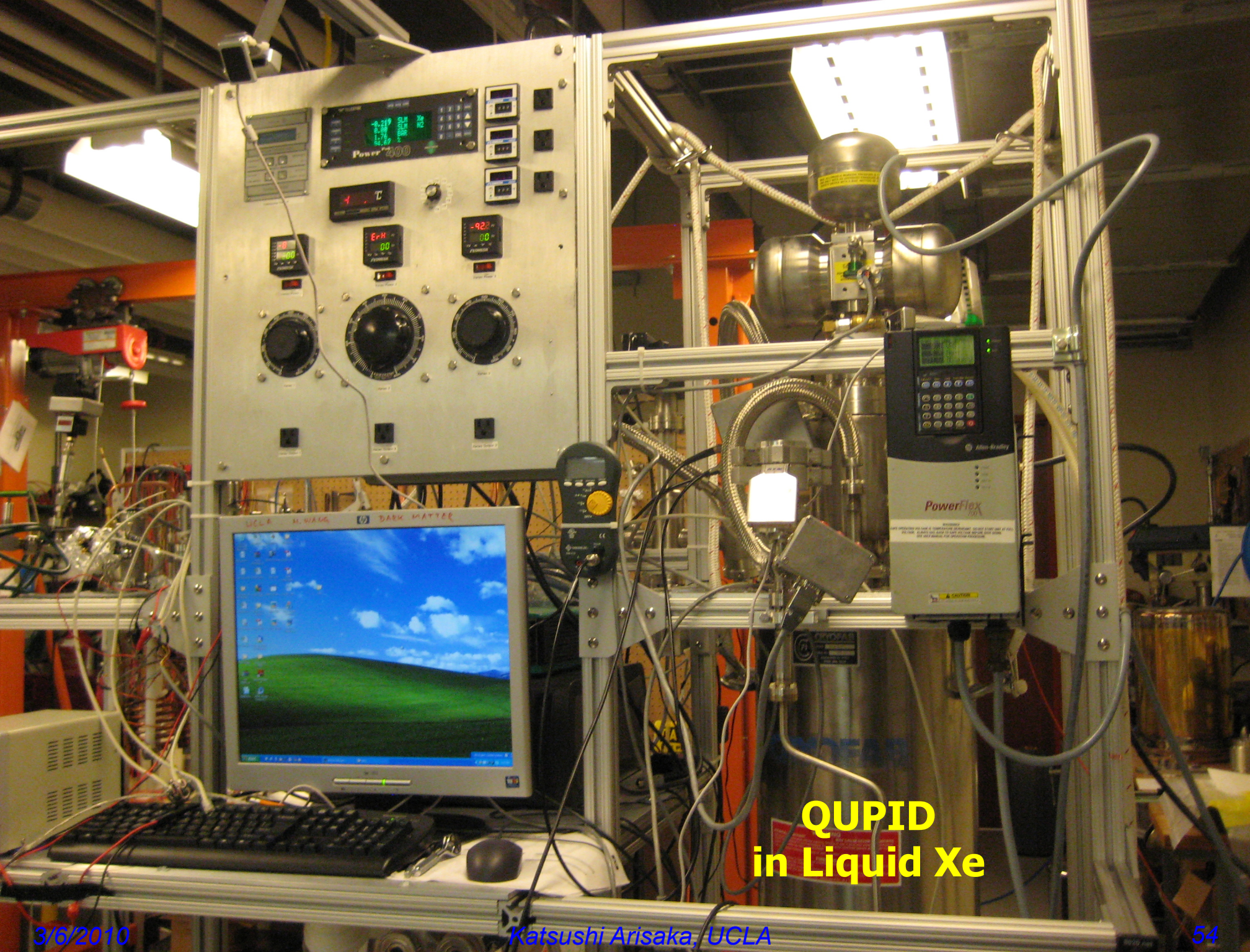

QUPID in Liquid Xe

The first Scintillating lights detected by QUPID from ^{57}Co in Liquid Xenon

1, 2, and 3 Photoelectron Peaks

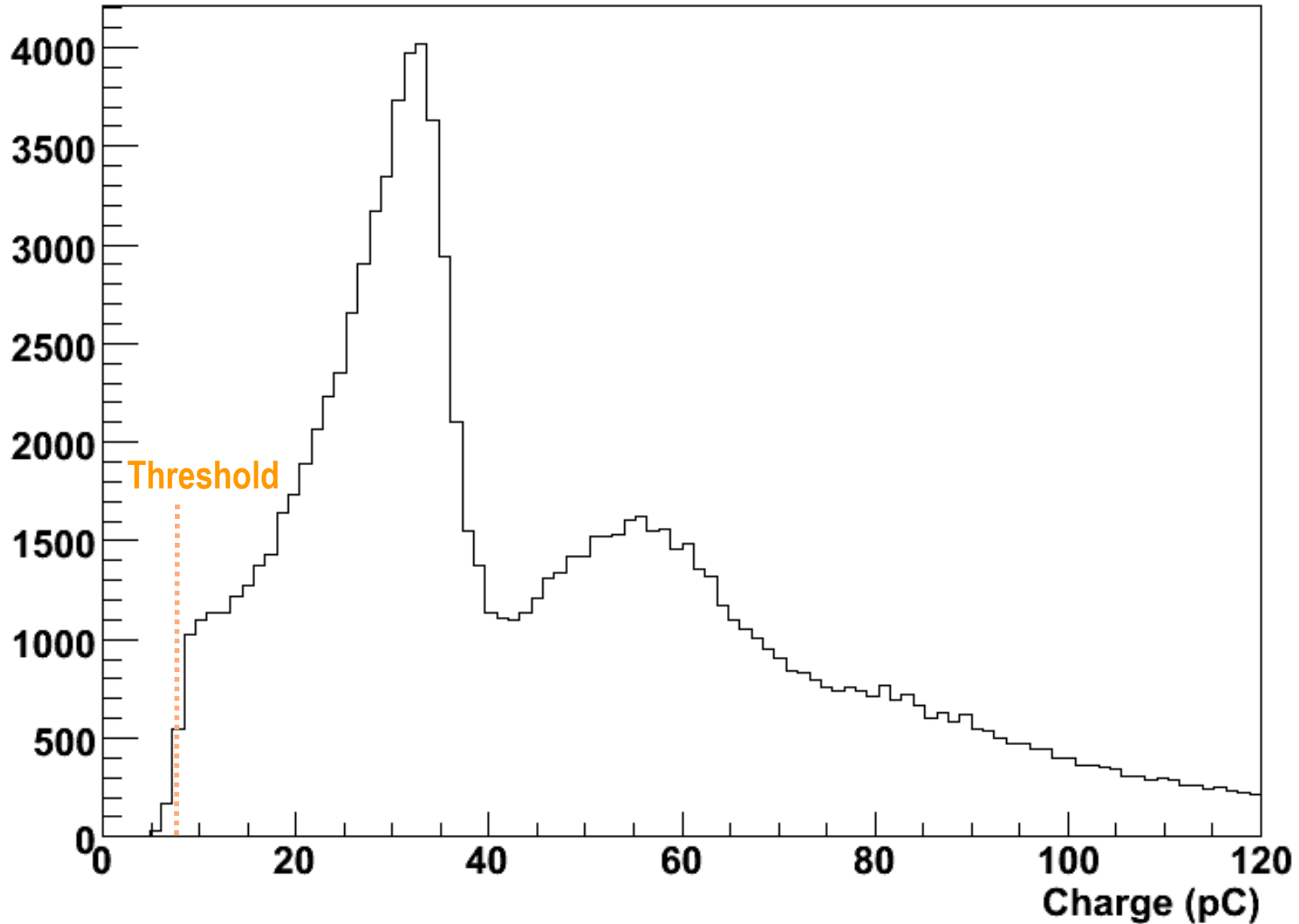

The first Scintillating lights detected by QUPID from ^{57}Co in Liquid Xenon

1, 2, and 3 Photoelectron Peaks

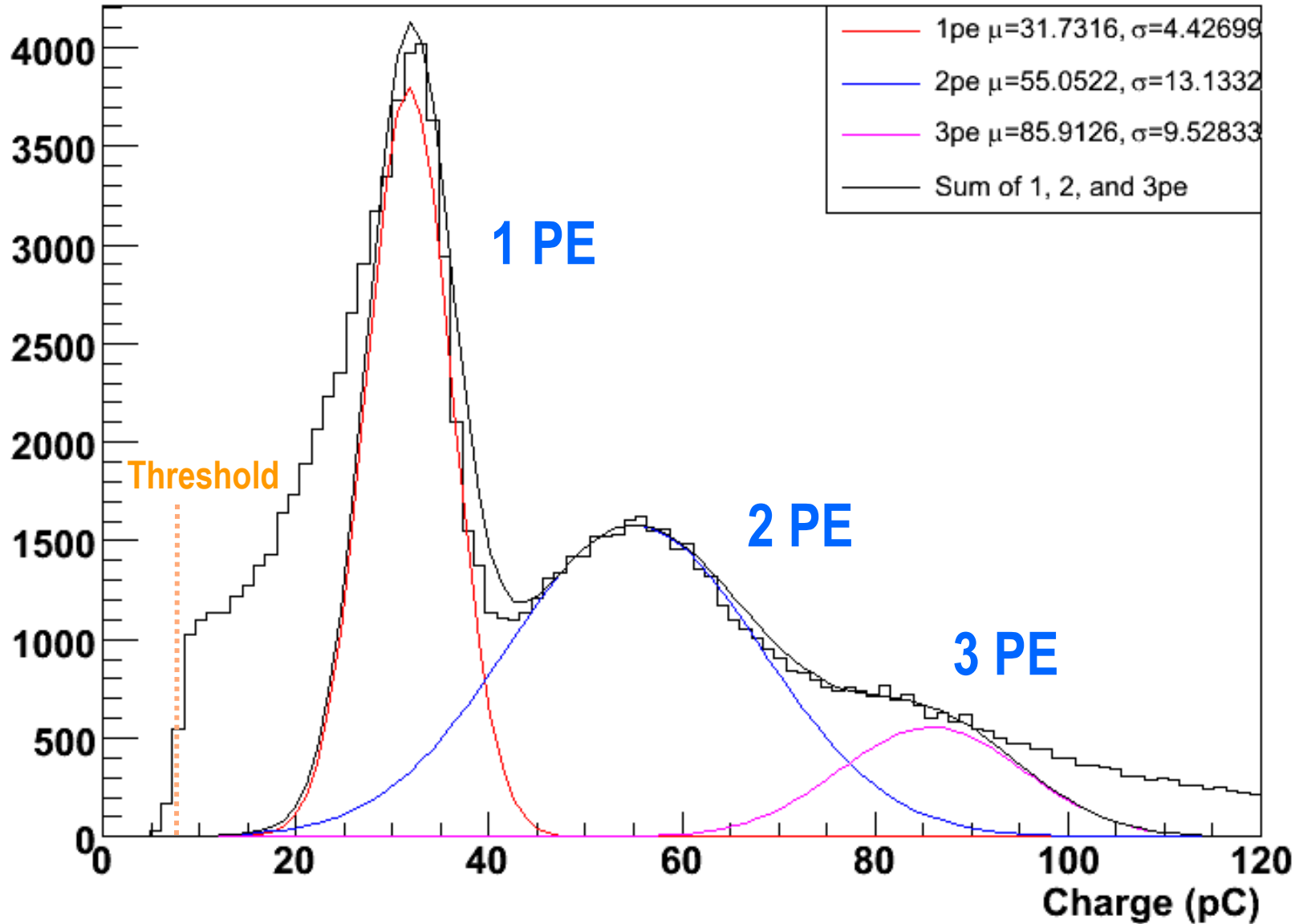

XENON1T

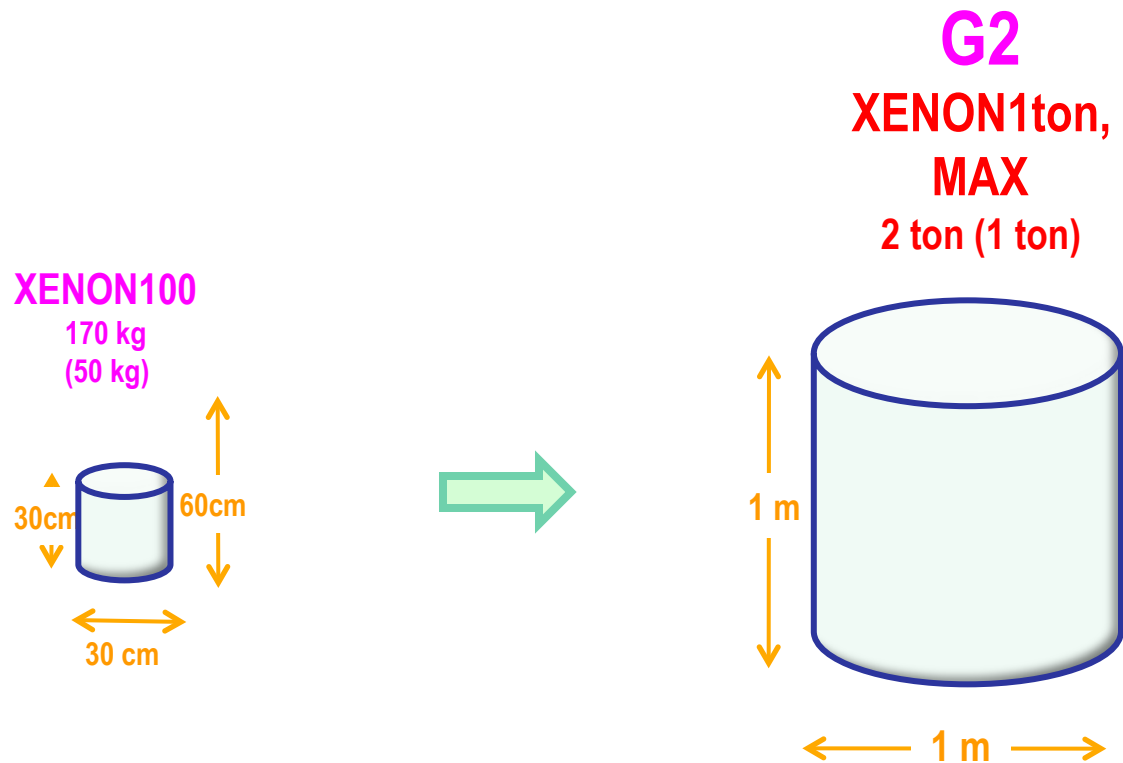

XENON 1ton Structure

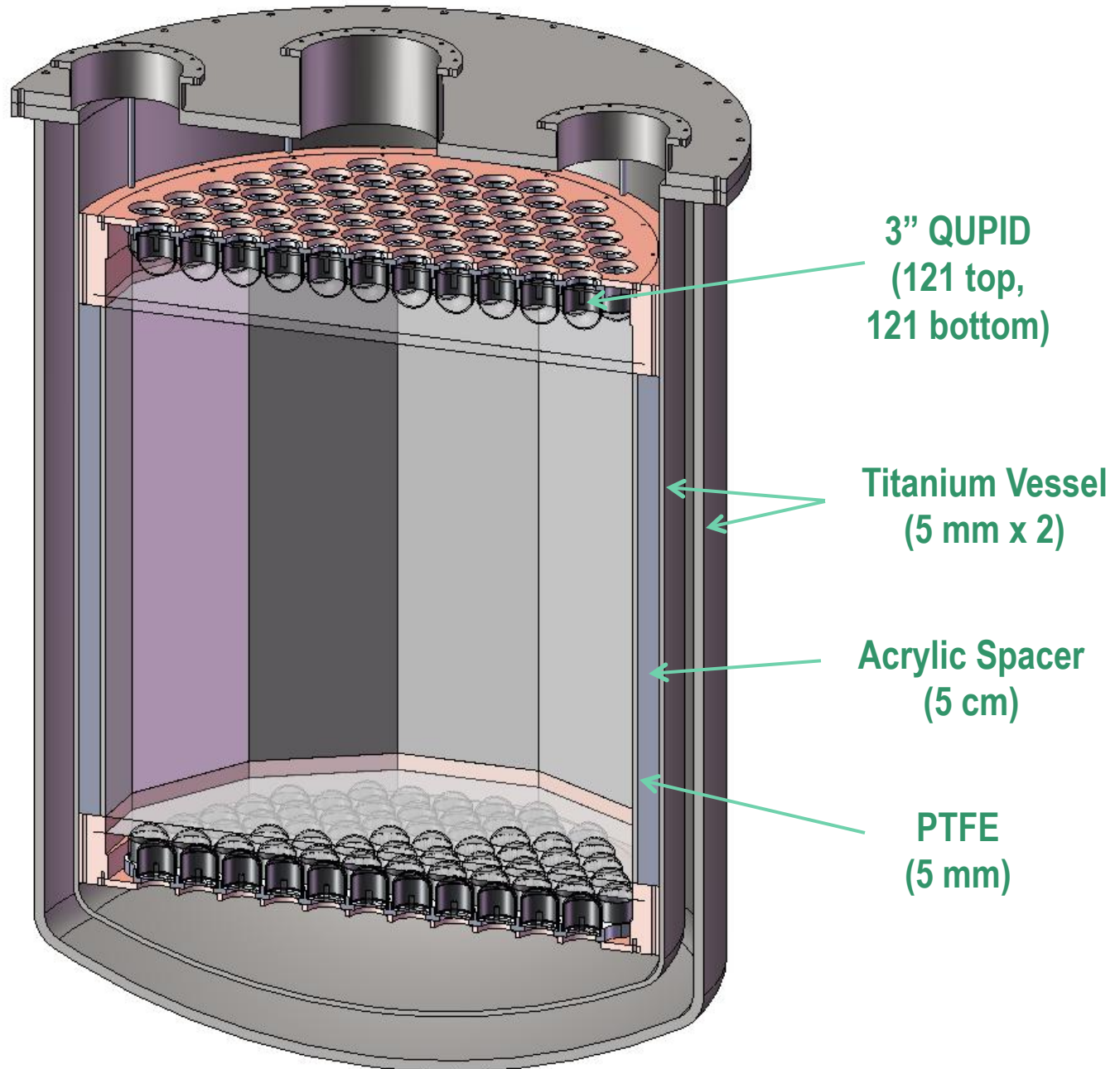

XENON 1Ton

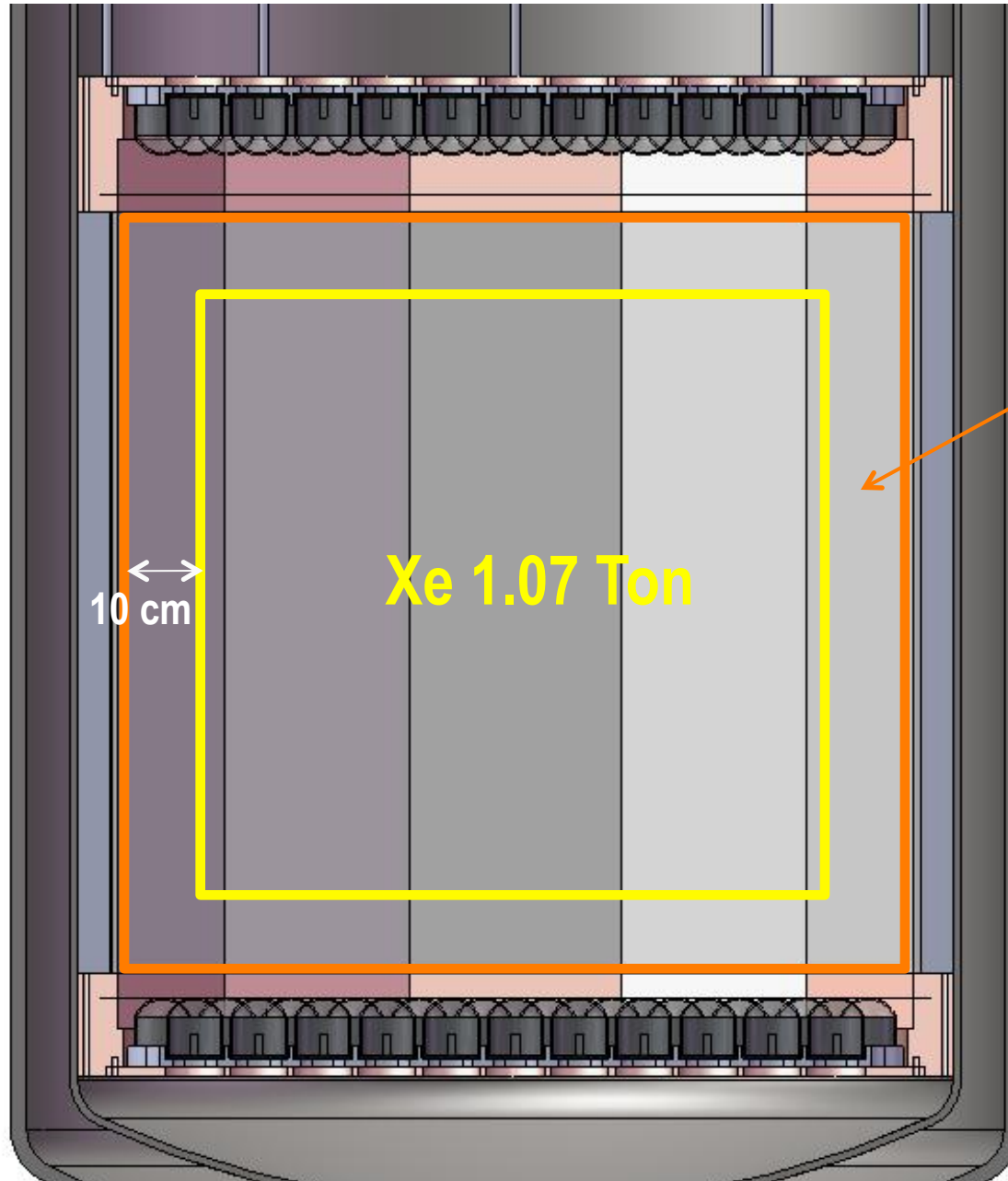

XENON 1ton Top Corner

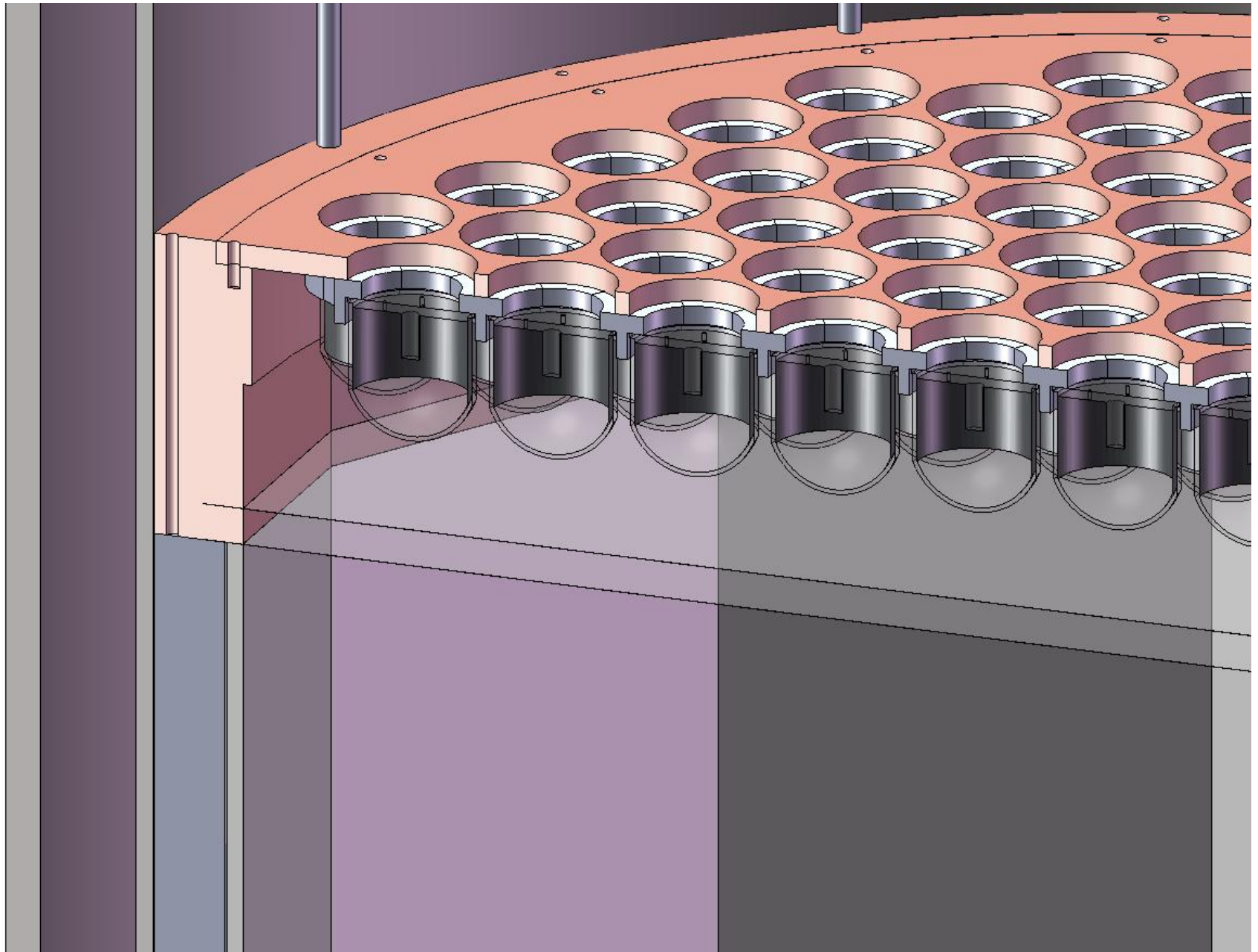

XENON 1ton with Water Tank Shielding

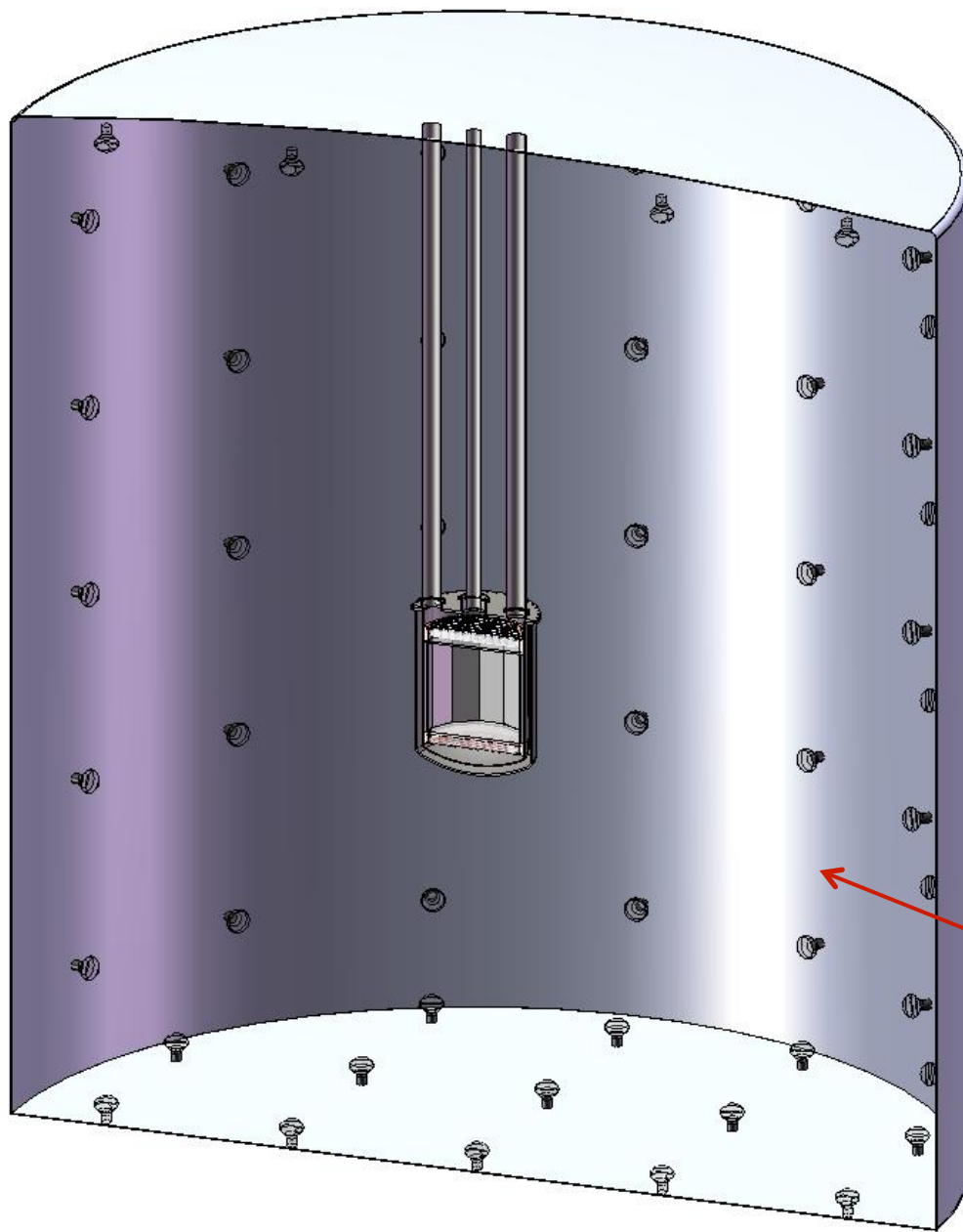

Water Tank
(11 m ϕ x 11 m H)

Gamma Background (After Multi-hit Cut and S2/S1 Cut)

Gamma Background (multi-hit cut, S2/S1 cut)

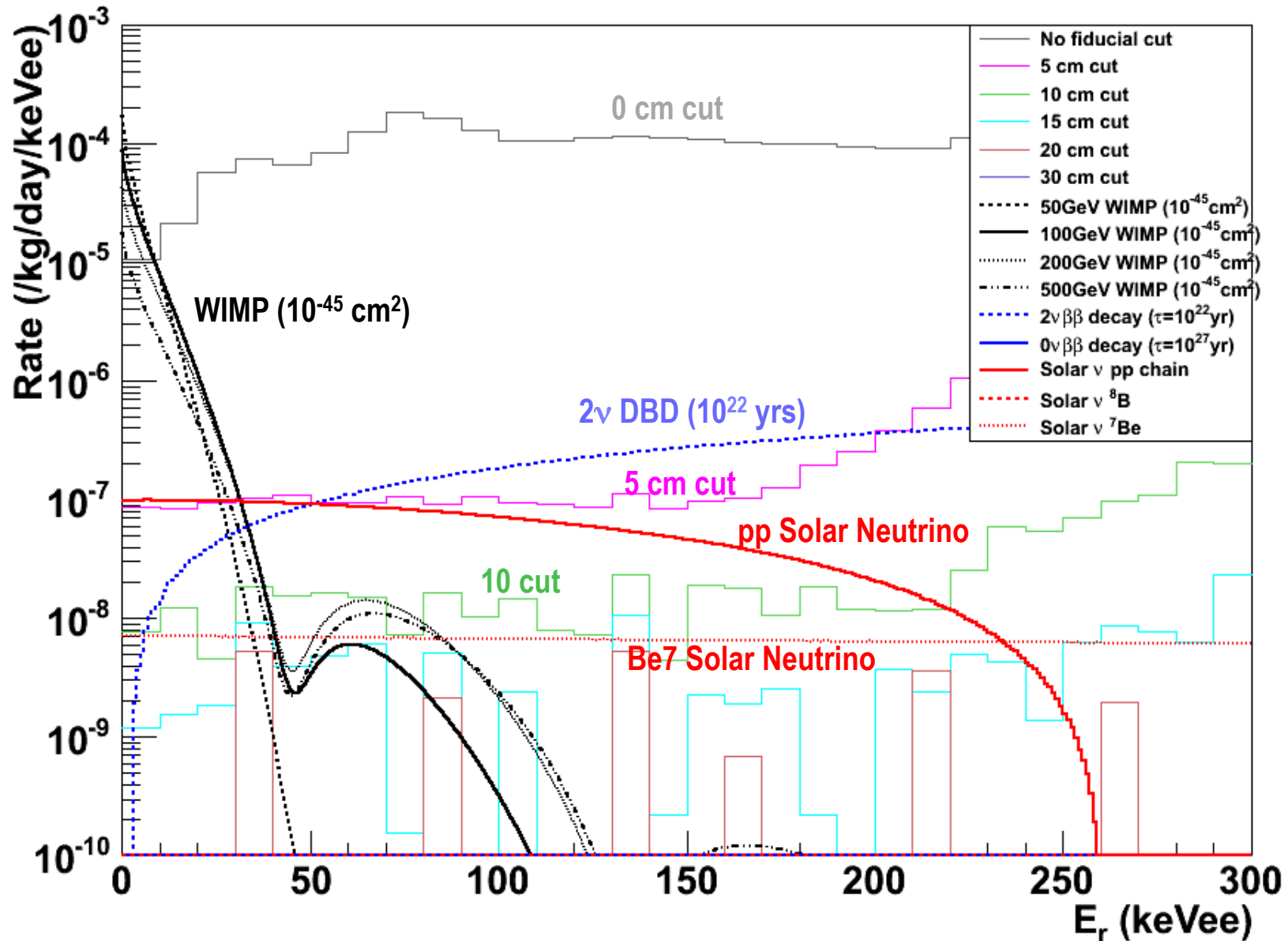

Expected Backgrounds in XENON 1Ton (100 Year, Multi-hit Cut)

Gamma Background (1 year, multi-hit cut, no S2/S1 cut, 2-18 keVee)

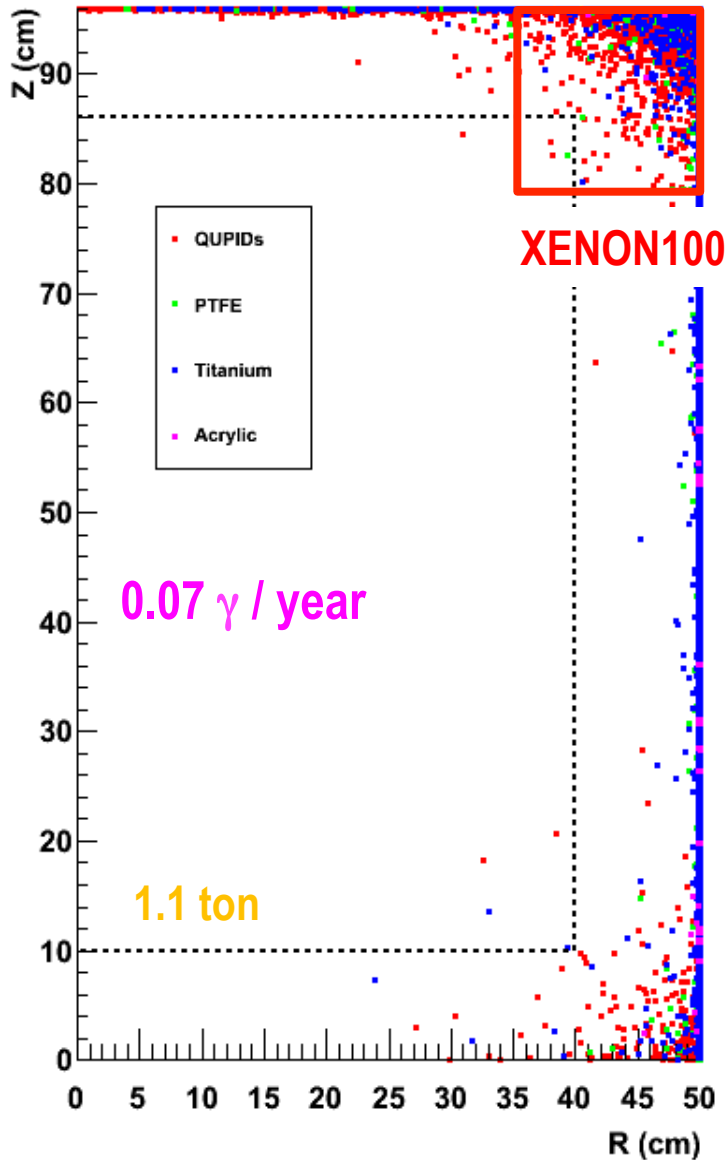

Neutron Background (100 years, multi-hit cut, 5-45 keVr)

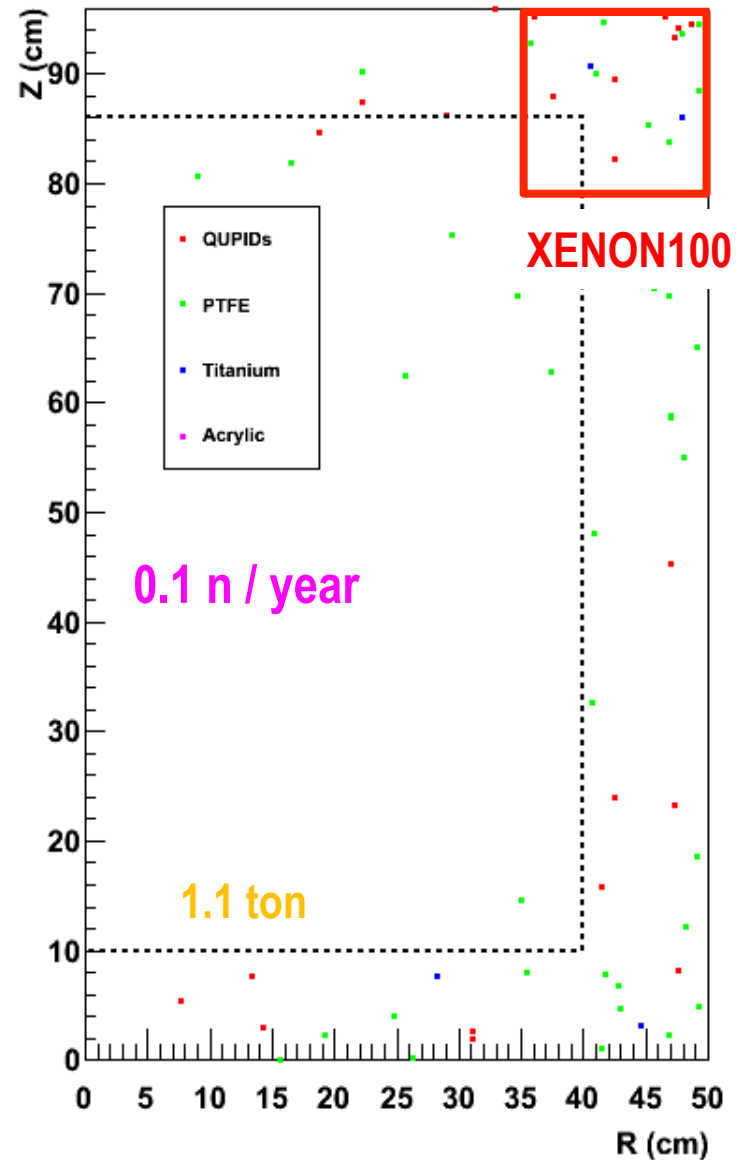

DarkSide 50

DarkSide 50 with 19 + 19 QUPIDs

- 50 kg of ^{39}Ar depleted Argon (33 kg fiducial)
- 19 + 19 = 38 QUPID
- Liquid Scintillator Active Veto

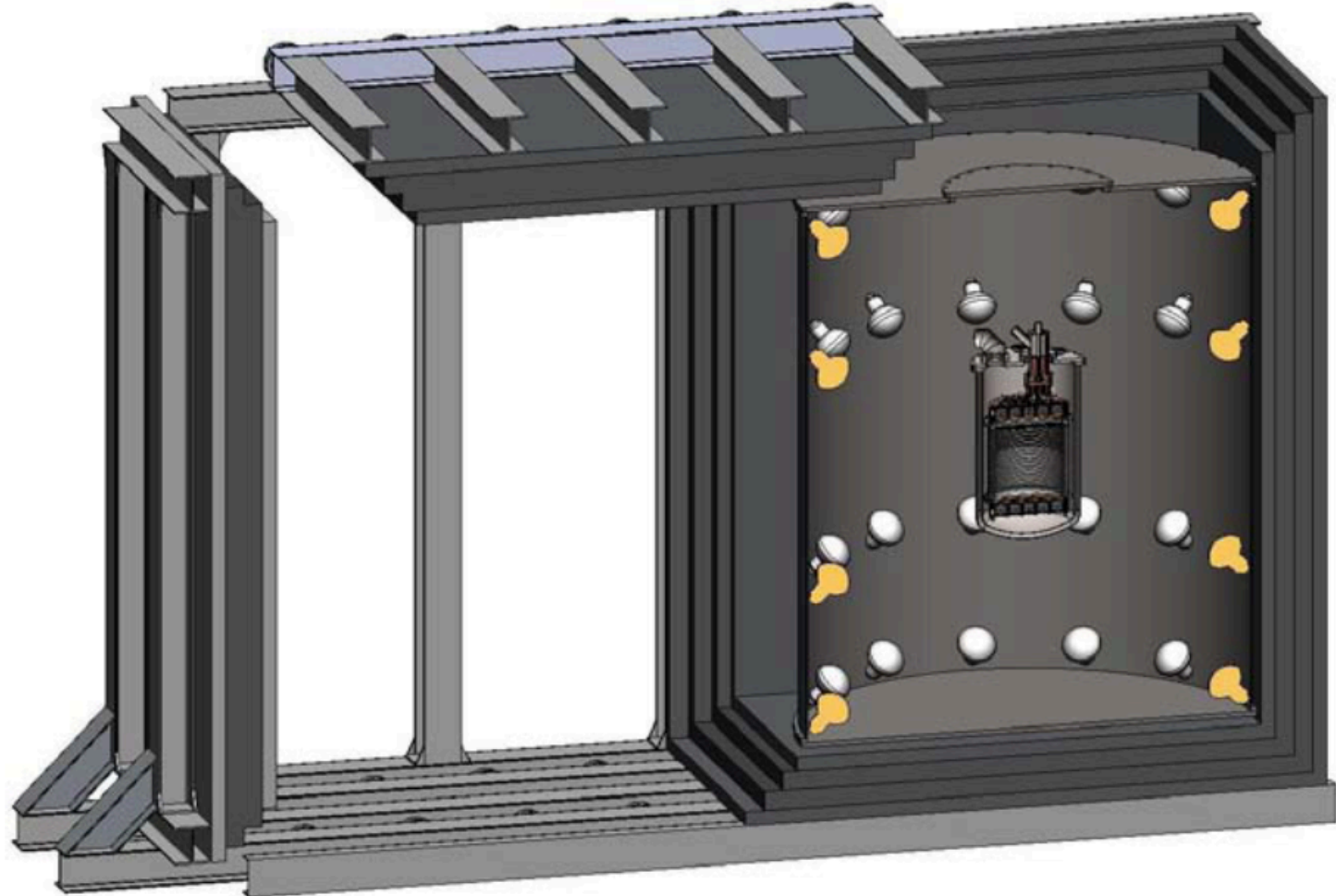
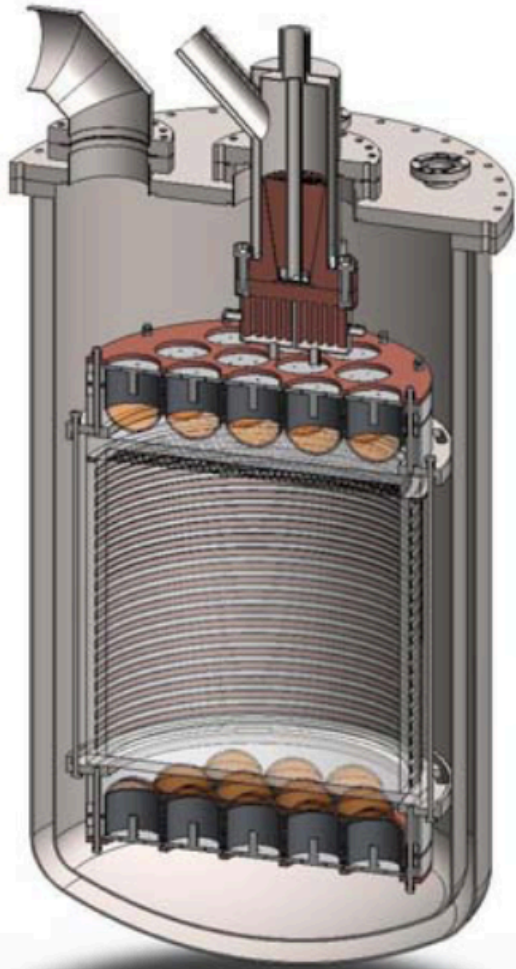

DarkSide Collaboration



Augustana College, USA Prof. Drew Alton

Black Hills State University, USA Prof. Dan Durben, Prof. Kara Keeter, Prof. Michael Zehfus

Fermi National Accelerator Laboratory, USA Dr. Steve Brice, Dr. Aaron Chou, Dr. Jeter Hall, Dr. Hans Jostlein, Dr. Stephen Pordes, Dr. Andrew Sonnenschein

Princeton University, USA Jason Brodsky, Prof. Frank Calaprice, Huajie Cao, Alvaro Chavarria, Ernst de Haas, Prof. Cristiano Galbiati, Eng. Augusto Goretti, Eng. Andrea Ianni, Tristen Hohman, Ben Loer, Pablo Mosteiro, Prof. Peter Meyers, Eng. David Montanari, Allan Nelson, Eng. Robert Parsells, Richard Saldanha, Eng. William Sands, Dr. Alex Wright, Jingke Xu

Temple University, USA Prof. Jeff Martoff, Prof. Susan Jansen-Varnum, Christy Martin, John Tatarowicz

University of California at Los Angeles, USA Prof. Katsushi Arisaka, Prof. David Cline, Chi Wai Lam, Kevin Lung, Prof. Peter F. Smith, Artin Teymourian, Dr. Hanguo Wang

University of Houston, USA Prof. Ed Hungerford and Prof. Lawrence Pinsky

University of Massachusetts at Amherst, USA Prof. Laura Cadonati and Prof. Andrea Pocar

University of Notre Dame, USA Prof. Philippe Collon, Daniel Robertson, Christopher Schmitt

University of Virginia, USA Prof. Kevin Lehmann

Properties of Noble Liquid

	Unit	Neon	Argon	Xenon
Z		10	18	54
A		20	40	~132
Liquid Density	g/cc	1.21	1.4	3.06
Energy Loss (dE/dX)	MeV/cm	1.4	2.1	3.8
Radiation Length	cm	24	14	2.8
Collision Length	cm	80	80	34
Boiling Temperature	°K	27.1	87.3	165
Scintillation Wavelength	nm	85	125	175
Scintillation	photon/keV	30	40	46
Ionization	e-/keV	46	42	64
Decay time (Fast Component)	nsec	19	7	4
Decay time (Slow Component)	nsec	1500	1600	27
Isotope		No	³⁹ Ar (1 Bq/kg)	¹³⁶ Xe
Price	\$/ton	\$90k	\$2k	~\$1M
Single Phase Experiments		CLEAN	DEAP, CLEAN	XMASS
Double Phase Experiments			WARP, ArDM, DarkSide, MAX, XAX	ZEPLIN, LUX, XMASS, XENON, MAX, XAX

Pulse Shaping Discrimination by Ar

(a) Neutron induced ion recoils

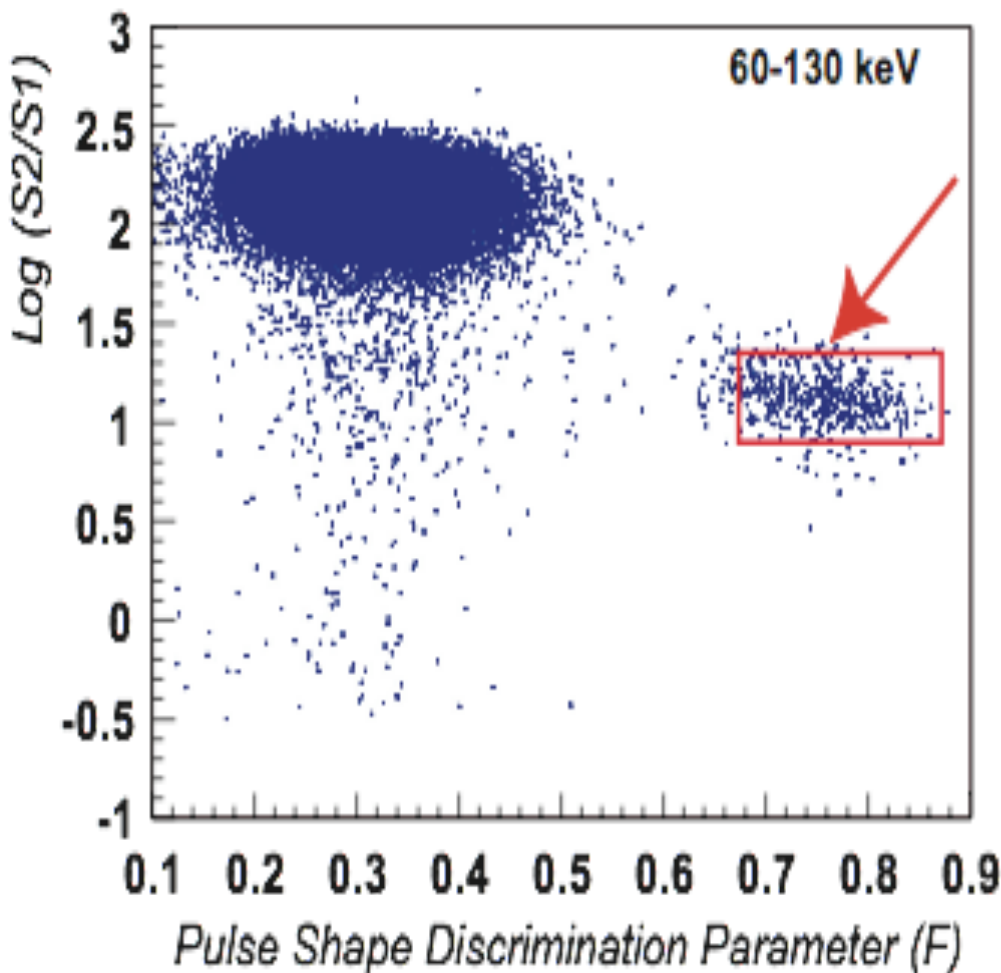

(b) WIMP Exposure of 96.5 kg · day

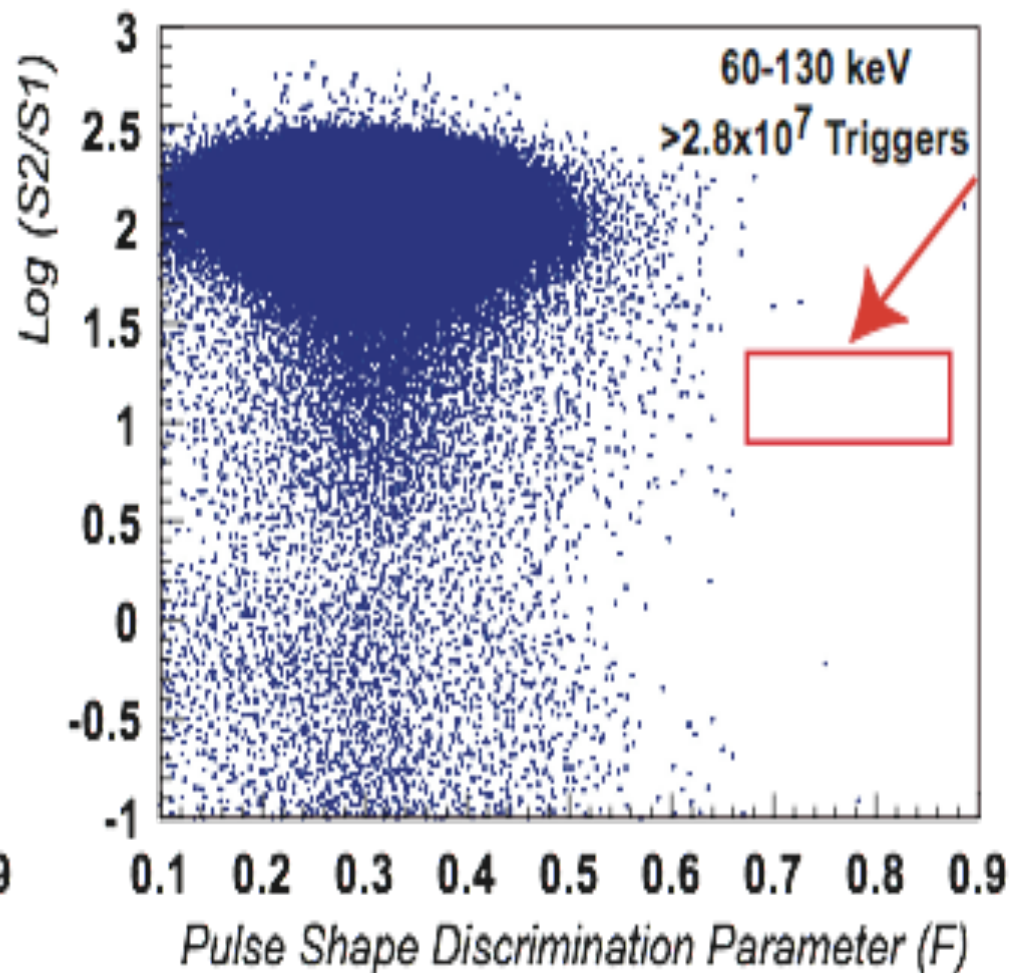



**Princeton Prototype Plant for Depleted Argon:
Achieved 0.5 kg/day (depletion >25), 15 kg accumulated**

MAX and XAX

DUSEL (\$750M project by NSF)

DUSEL Deep Underground Science and Engineering Laboratory at Homestake, SD



Six and a half Empire State Buildings for scale

Shallow Lab

Mid-level

Deep Campus

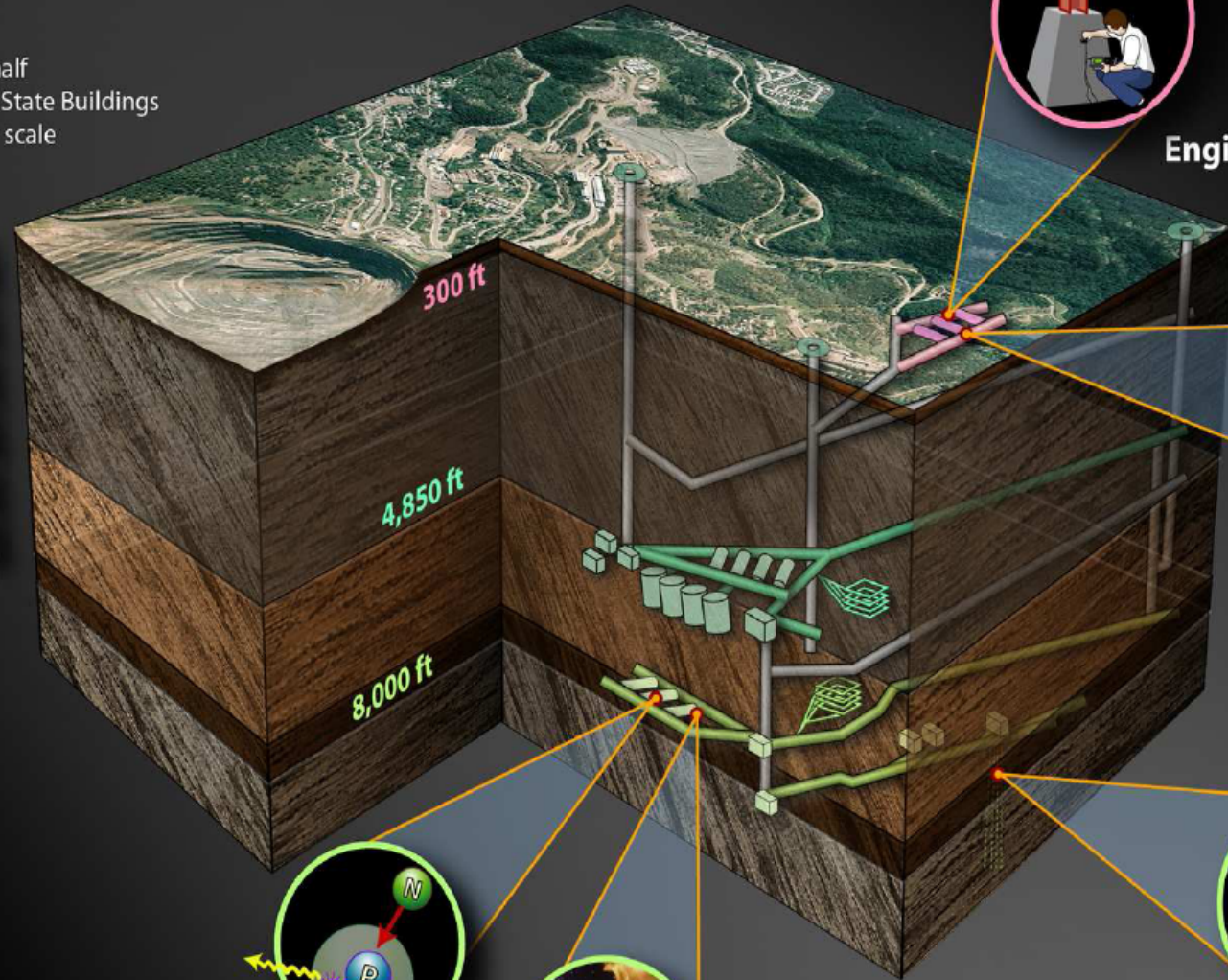

Engineering

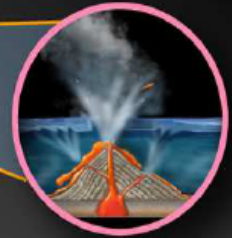

Geoscience

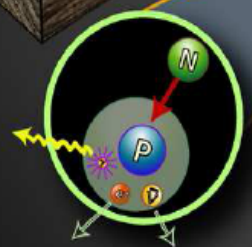

Physics



Astrophysics

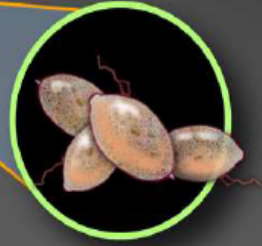

Biology



XAX by UCLA Group (Aug, 2008)

Astroparticle Physics 31 (2009) 63–74



ELSEVIER

Contents lists available at ScienceDirect

Astroparticle Physics

journal homepage: www.elsevier.com/locate/astropart



XAX: A multi-ton, multi-target detection system for dark matter, double beta decay and pp solar neutrinos

K. Arisaka *, H. Wang, P.F. Smith, D. Cline, A. Teymourian, E. Brown, W. Ooi, D. Aharoni, C.W. Lam, K. Lung, S. Davies, M. Price

Department of Physics and Astronomy, University of California, Los Angeles, CA 90024, USA

ARTICLE INFO

Article history:

Received 28 August 2008

Received in revised form 17 November 2008

Accepted 17 November 2008

Available online 10 December 2008

Keywords:

Dark matter

WIMPs

Double beta decay

Solar neutrino

ABSTRACT

A multi-target detection system XAX, comprising concentric 10 ton targets of ^{136}Xe and $^{129/131}\text{Xe}$, together with a geometrically similar or larger target of liquid Ar, is described. Each is configured as a two-phase scintillation/ionization TPC detector, enhanced by a full 4π array of ultra-low radioactivity quartz photon intensifying detectors (QUPIDs) replacing the conventional photomultipliers for detection of scintillation light. It is shown that background levels in XAX can be reduced to the level required for dark matter particle (WIMP) mass measurement at a 10^{-10} pb WIMP-nucleon cross-section, with single-event sensitivity below 10^{-11} pb. The use of multiple target elements allows for confirmation of the A^2 dependence of a coherent cross-section, and the different Xe isotopes provide information on the spin-dependence of the dark matter interaction. The event rates observed by Xe and Ar would modulate annually with opposite phases from each other for WIMP mass $>\sim 100$ GeV/ c^2 . The large target mass of ^{136}Xe and high degree of background reduction allow neutrinoless double beta decay to be observed with lifetimes of 10^{27} – 10^{28} years, corresponding to the Majorana neutrino mass range 0.01–0.1 eV, the most likely range from observed neutrino mass differences. The use of a ^{136}Xe -depleted $^{129/131}\text{Xe}$ target will also allow measurement of the pp solar neutrino spectrum to a precision of 1–2%.

© 2008 Elsevier B.V. All rights reserved.

Original Concept of XAX

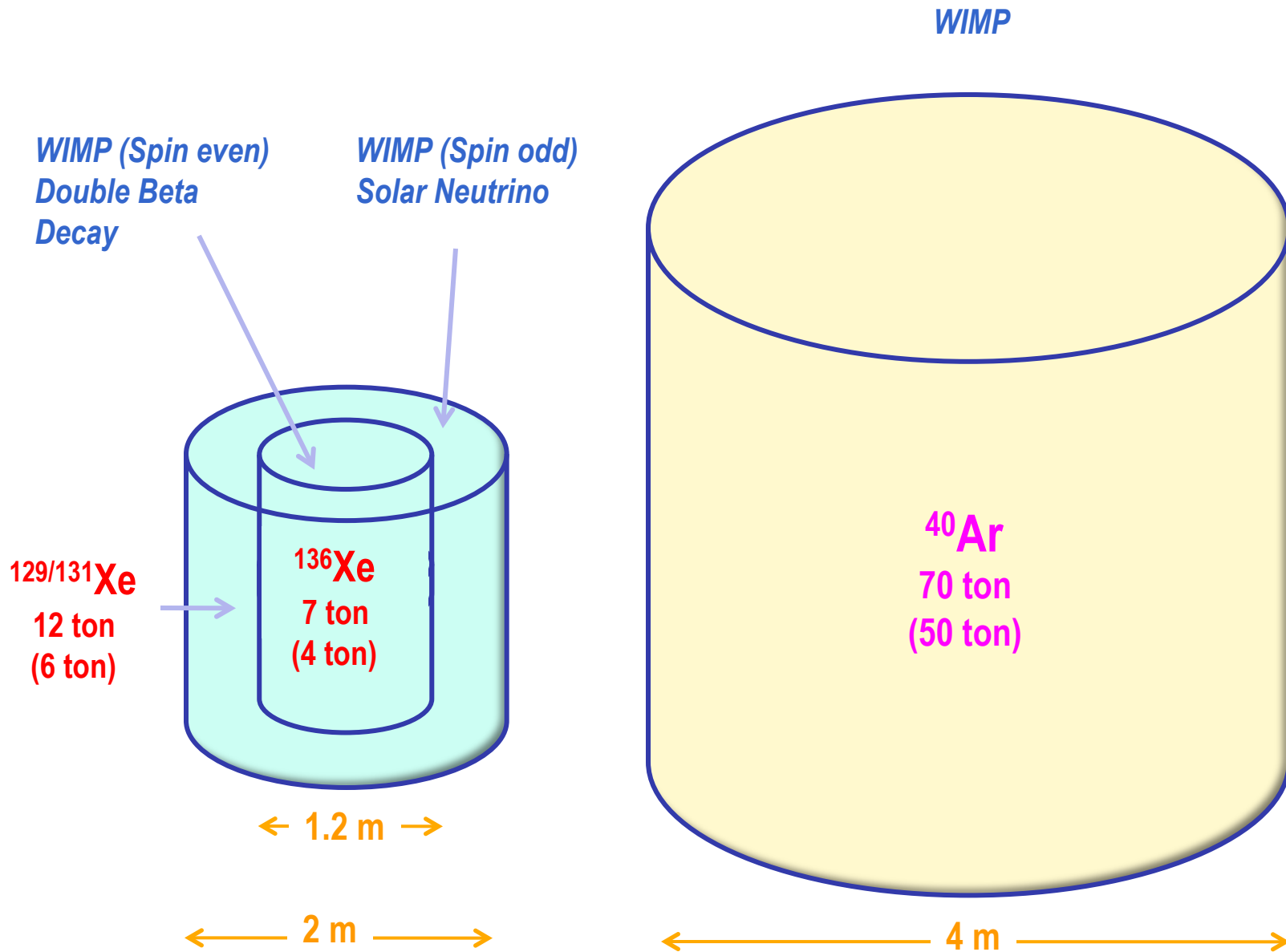

G2 and G3 facilities at DUSEL

defined by PASAG (Oct, 2009)

	G2	G3
Sensitivity	$< 10^{-46} \text{ cm}^2$	$< 10^{-47} \text{ cm}^2$
Target Mass	$\sim 1 \text{ Ton}$	$\sim 10 \text{ Ton}$
Cost	$\$15\text{M} - \20M	$\sim \$50\text{M}$

Supports on both Xe and Ar

To advance the CDMS technology, **PASAG** recommends a technical review of **SuperCDMS** in **FY2010** to evaluate the performance of the new detectors currently in operation at **Soudan**. Funding for the **100-kg SuperCDMS-SNOLAB** experiment should begin as soon as the detectors meet the design requirements.

A future xenon program that avoids duplicate efforts and meets the technical requirements for low background should be supported in any of the funding scenarios.

The liquid argon technique may be especially promising with the use of depleted argon and should also be explored in any of the funding scenarios.

MAX - Multi-ton Argon & Xenon

MAX Collaboration = XENON + DarkSide

Elena Aprile

Christiano Galbiati

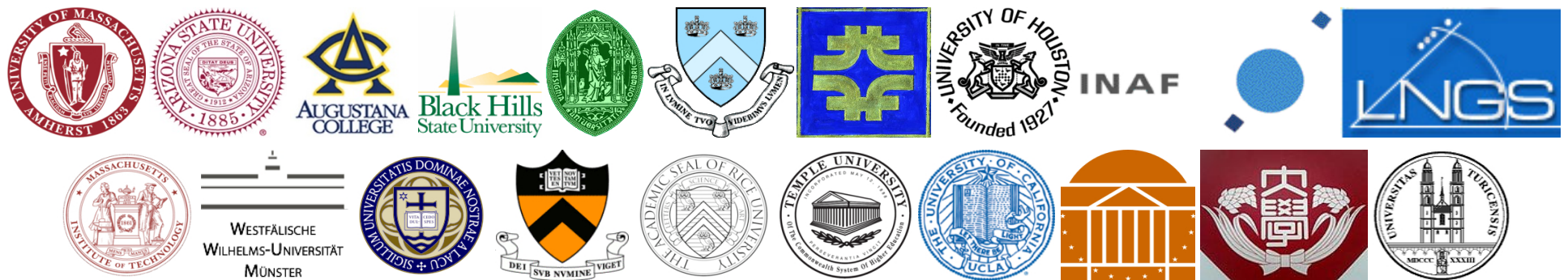

UMass Amherst, Arizona State University
Augustana College, Black Hills State University
Coimbra University, Columbia University
Fermilab, University of Houston, INAF, LNGS
MIT, University of Münster, University of Notre Dame
Princeton University, Rice University, Temple University
UCLA, University of Virginia, Waseda University
University of Zürich

90% CL Limits of SI Cross Section

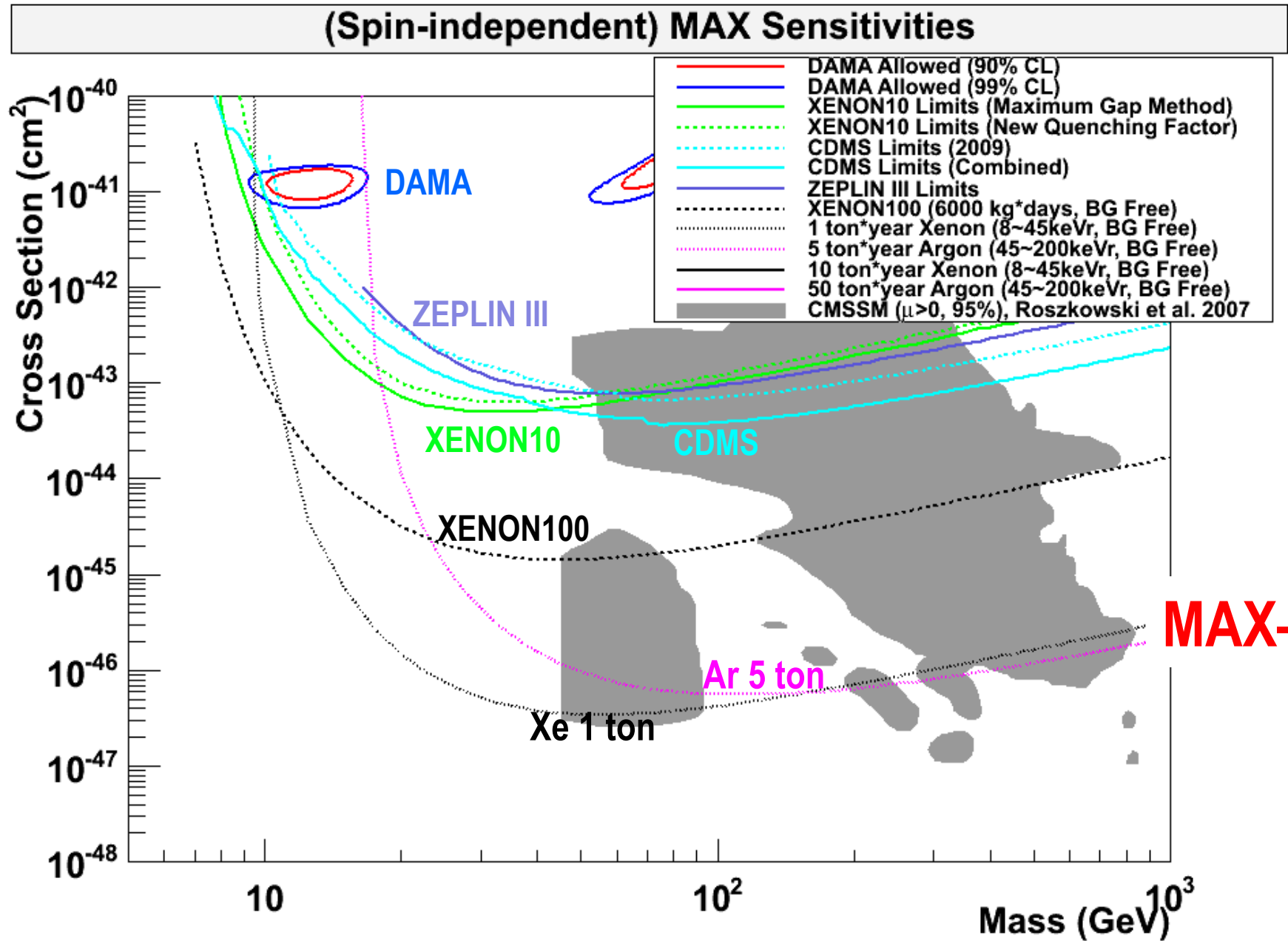

90% CL Limits of SI Cross Section

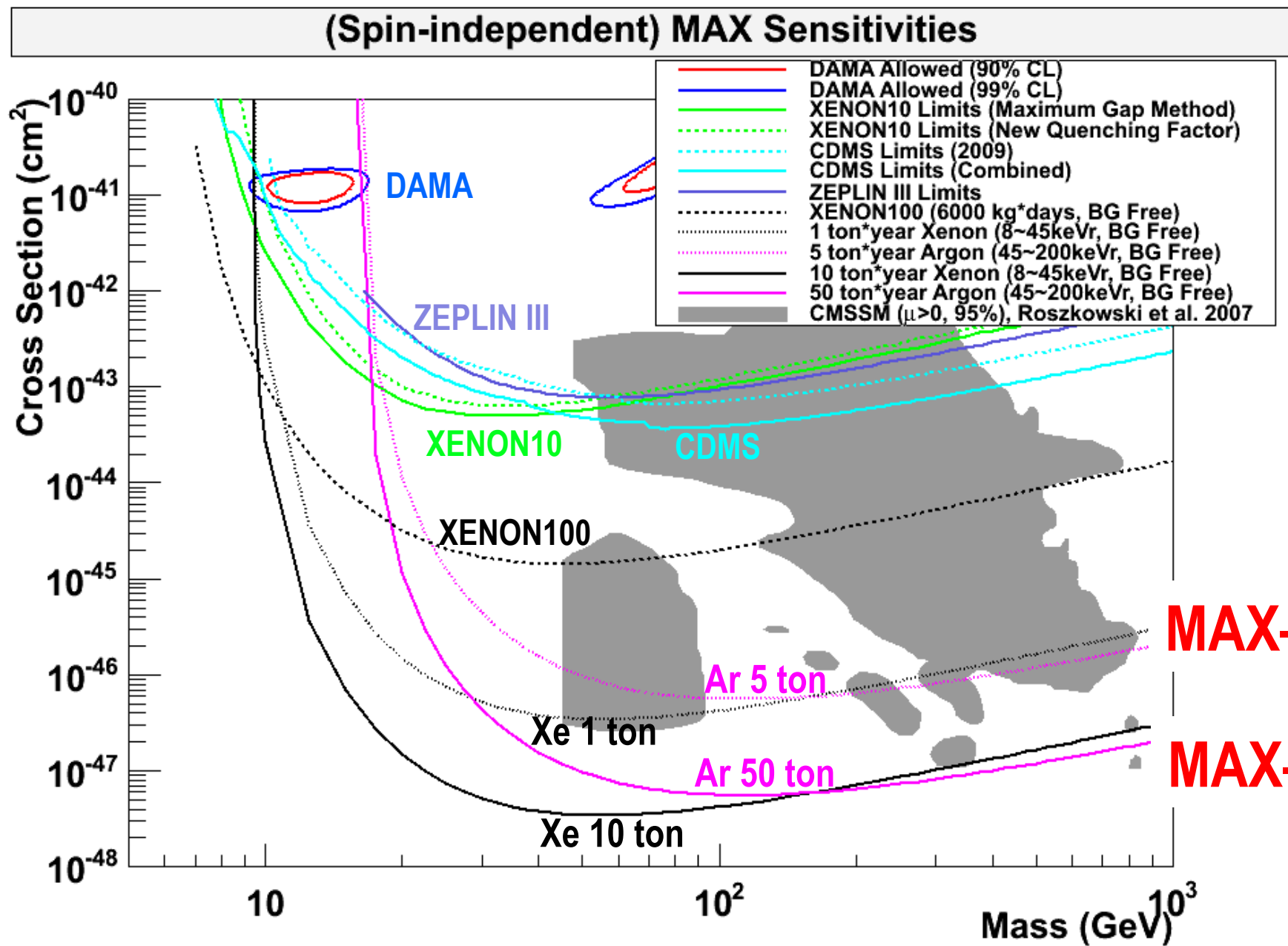

MAX – G3 Detector

Xe

**20 ton
(10 ton)**

^{40}Ar

**70 ton
(50 ton)**

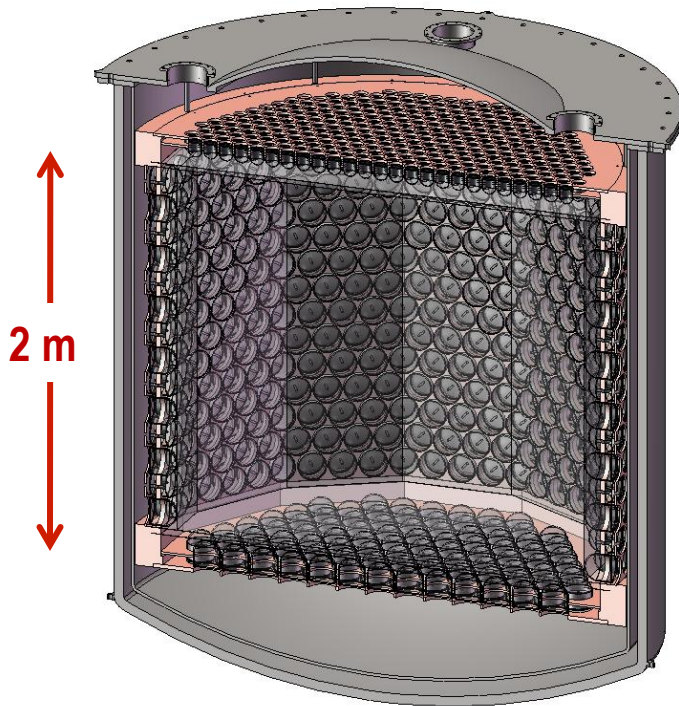

3" QUPID x 595 (Top)
6" QUPID x 825 (Side/Bottom)

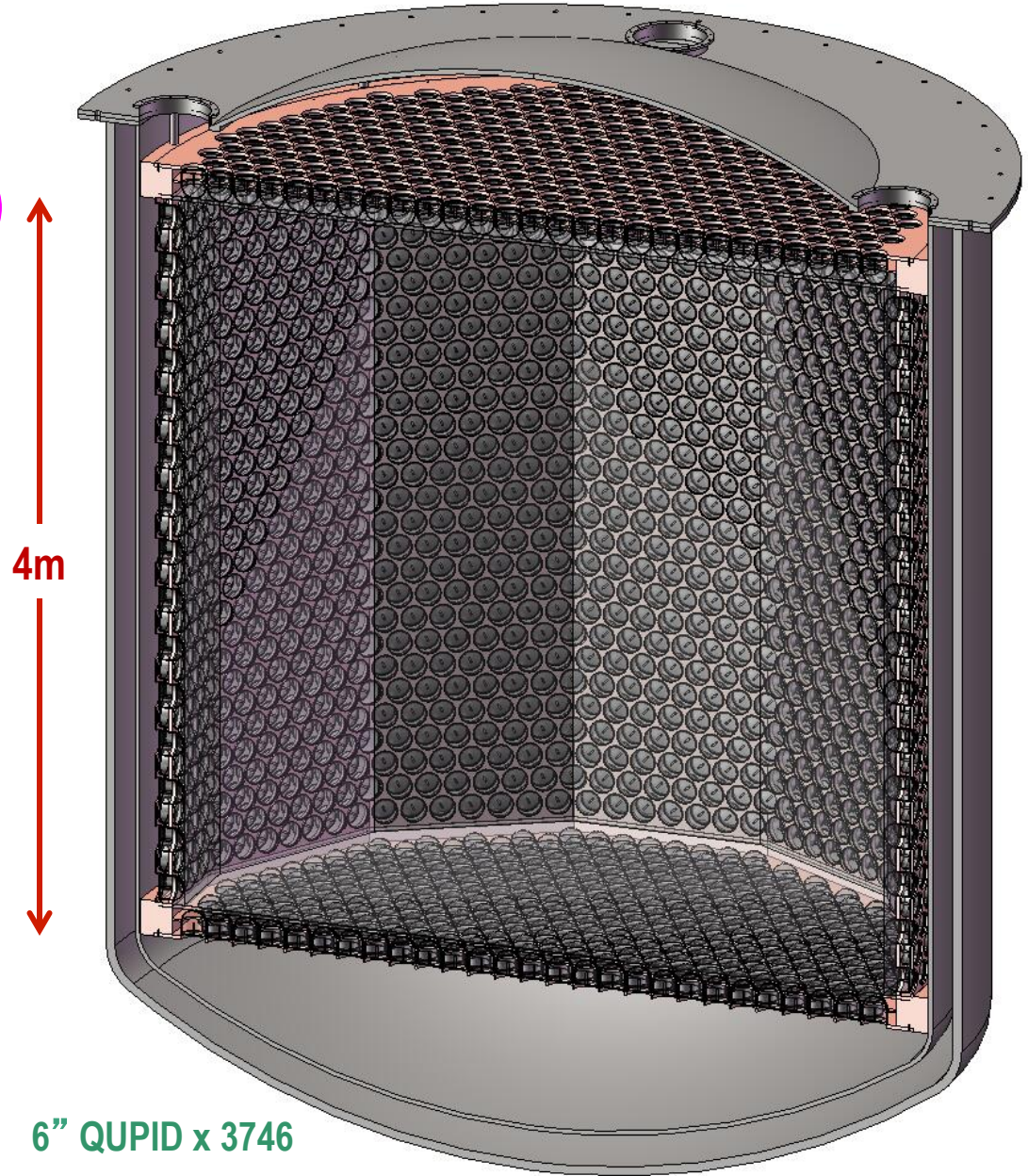

6" QUPID x 3746

Xe 10 ton Detector Structure

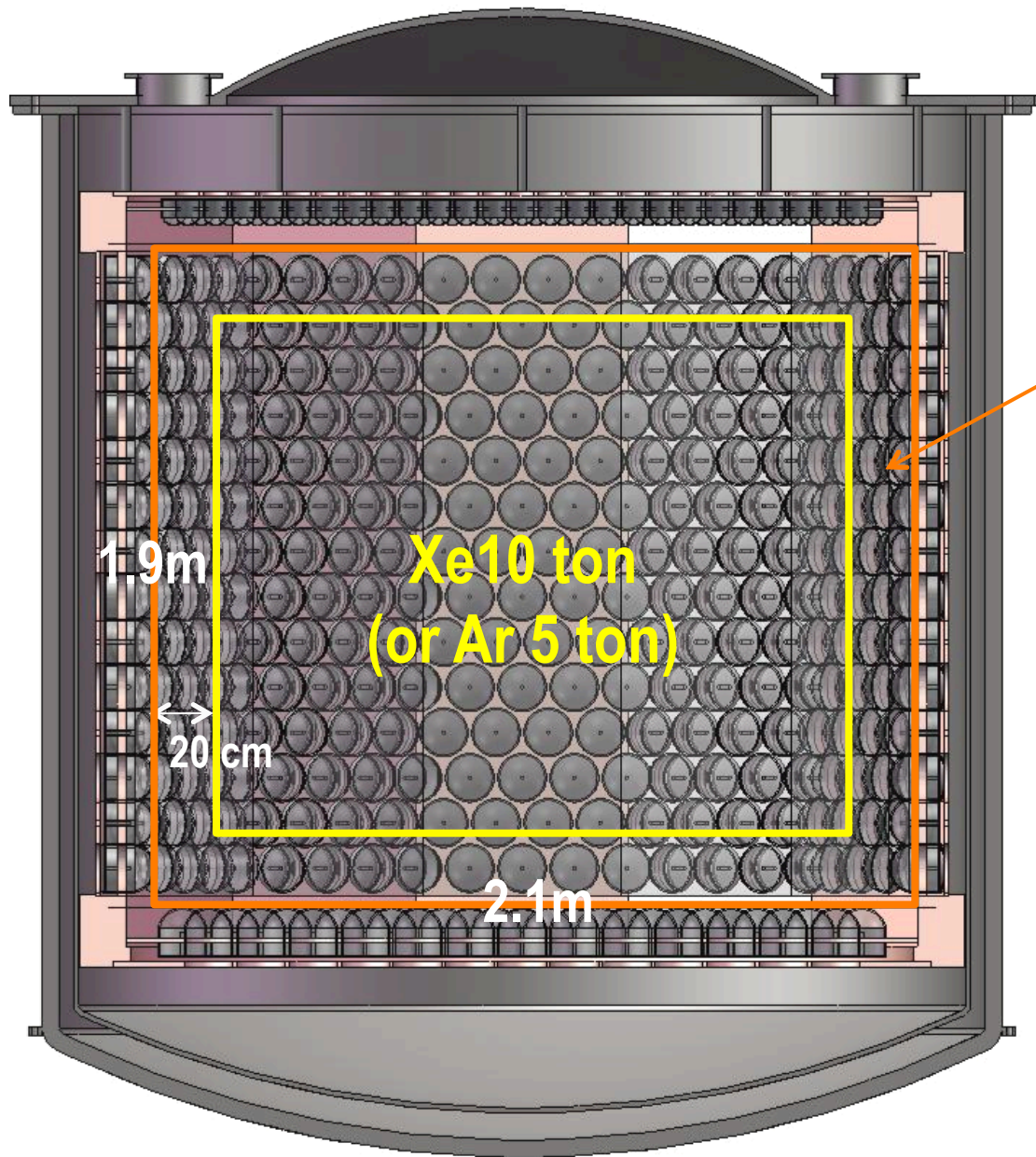

Xe 20 ton
(or Ar 10 ton)

Top: 3" QUPID x 595
Side: 6" QUPID x 672
Bottom: 6" QUPID x 163

Xe 10 ton Top-Corner

3" QUPID

Mesh Wire

Gas Xe (Ar)

Liquid Xe (Ar)

6" QUPID

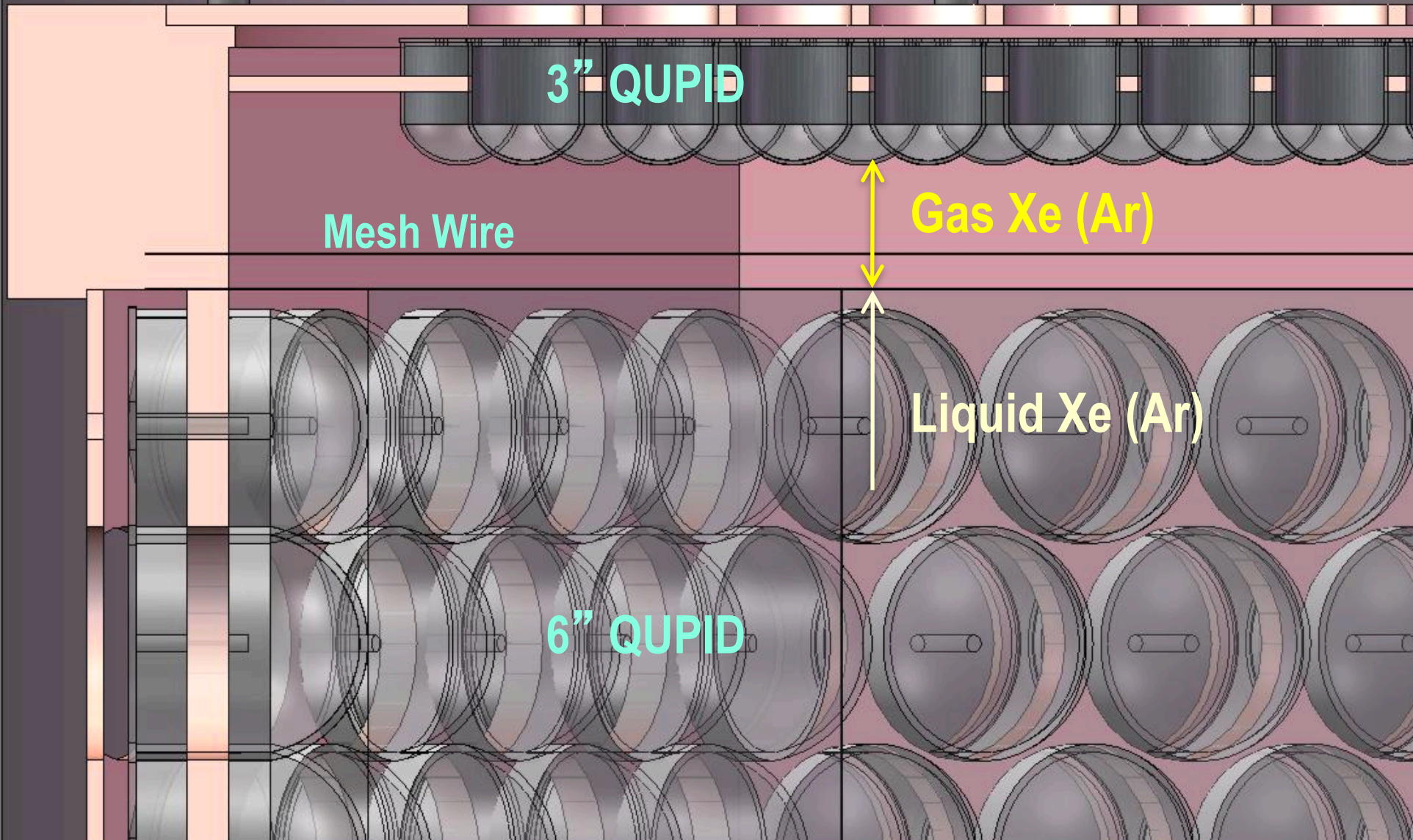

MAX Shielding Structure

Xe 20 ton (10 ton)

^{40}Ar 70 ton (50 ton)

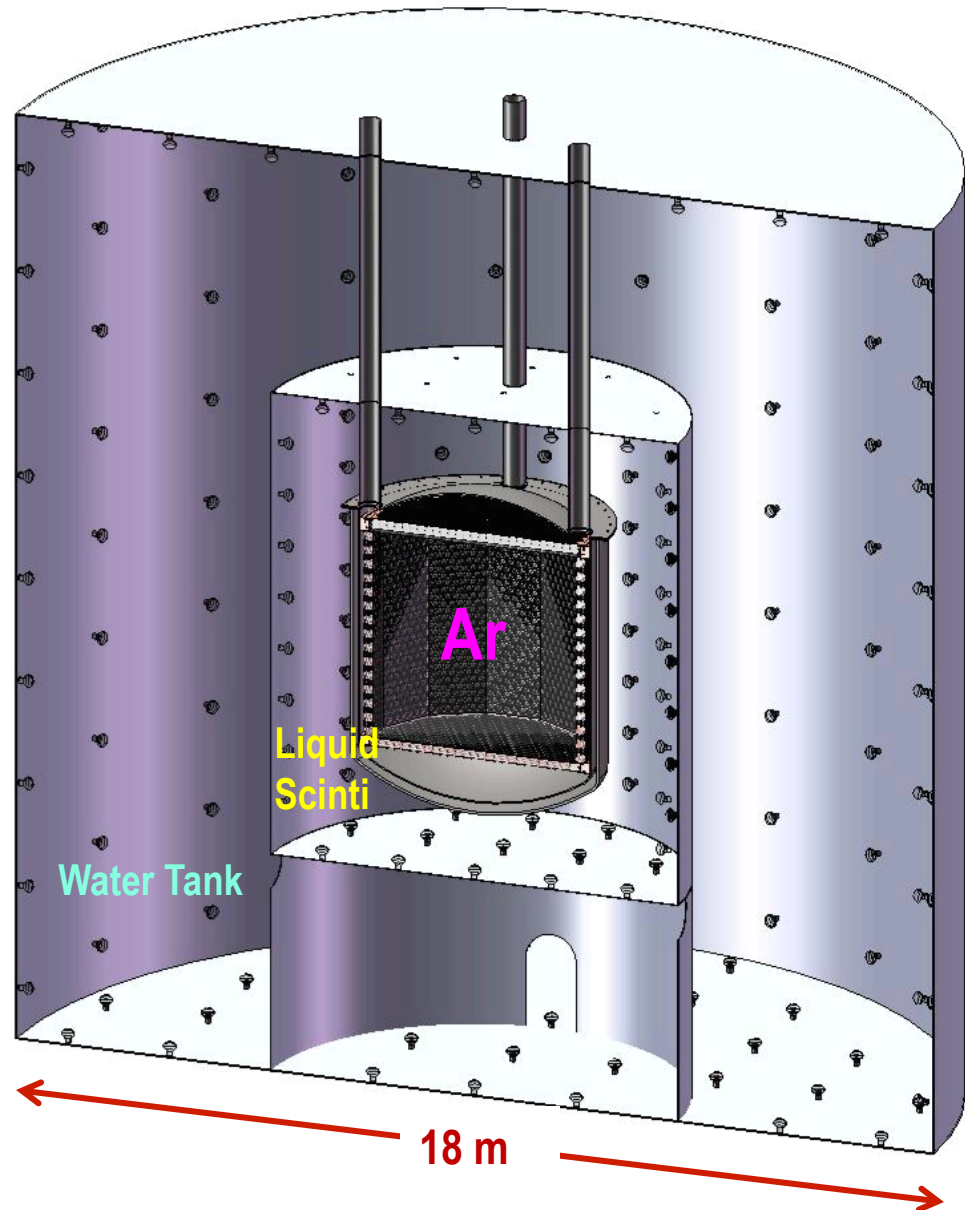
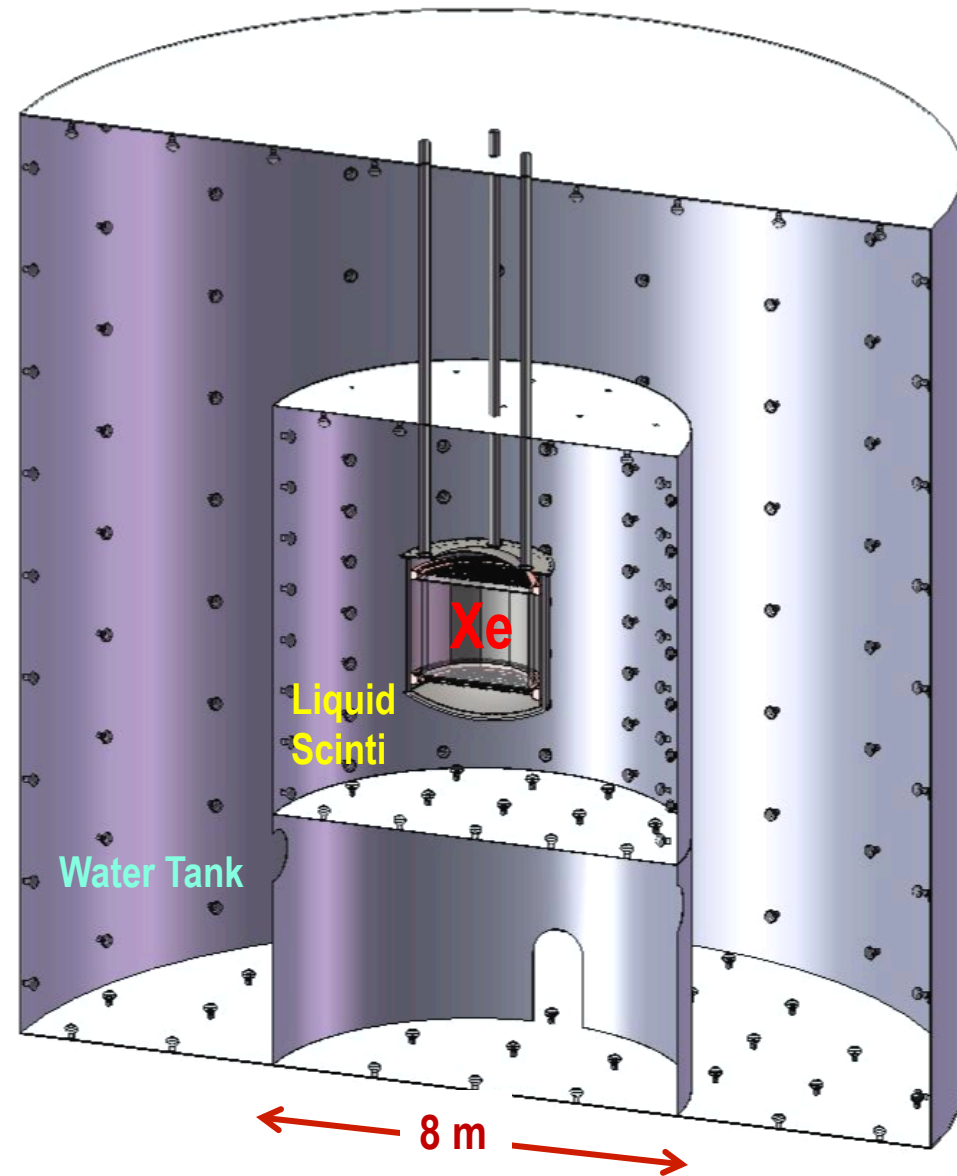

MAX Facility at DUSEL

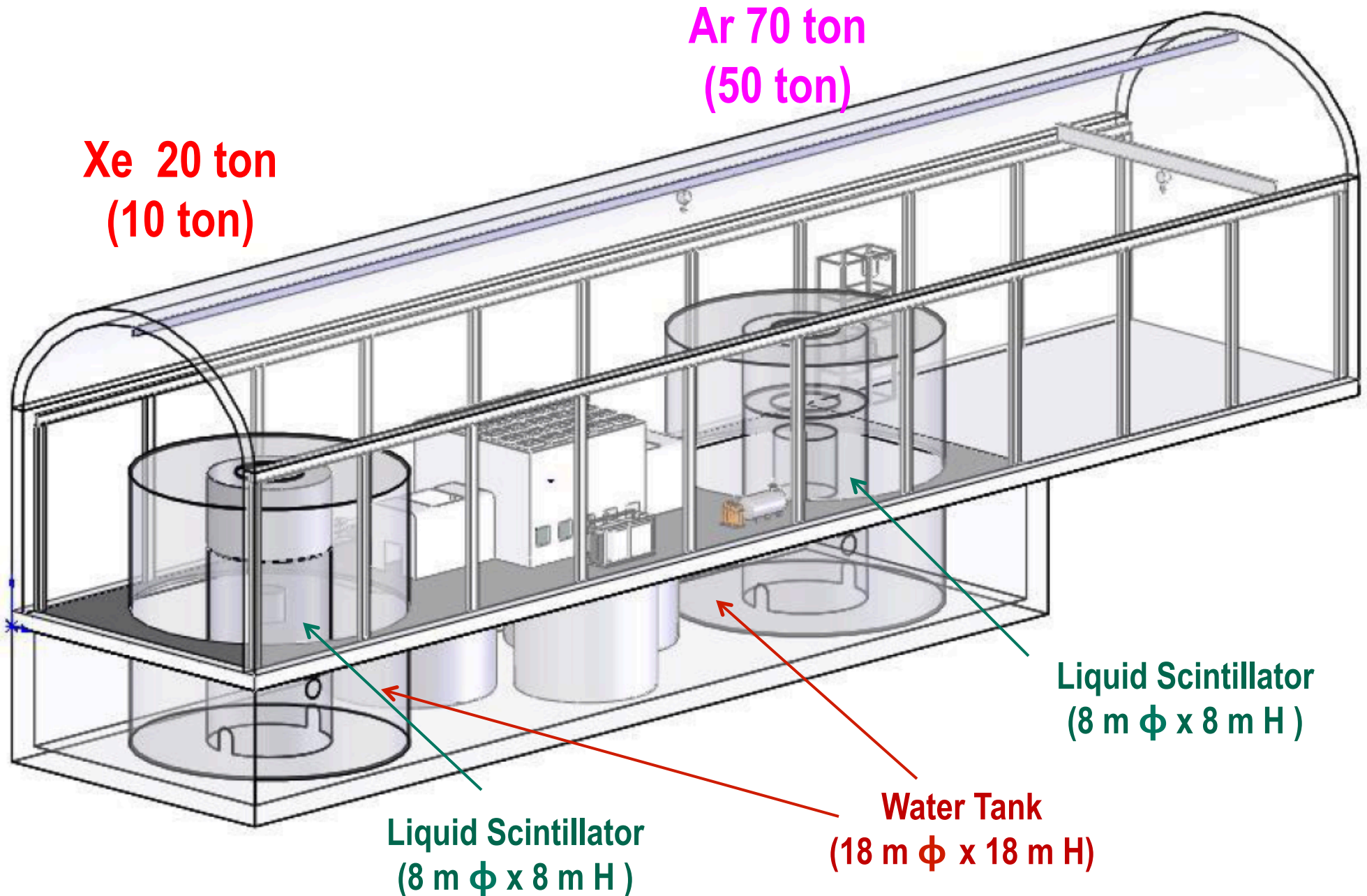

(SI) WIMP Energy Spectrum for Various Targets (Cross Section = 10^{-45}cm^2)

(SI) WIMP Recoil Energy Spectrum ($M = 100\text{GeV}$, $\sigma = 10^{-45}\text{cm}^2$)

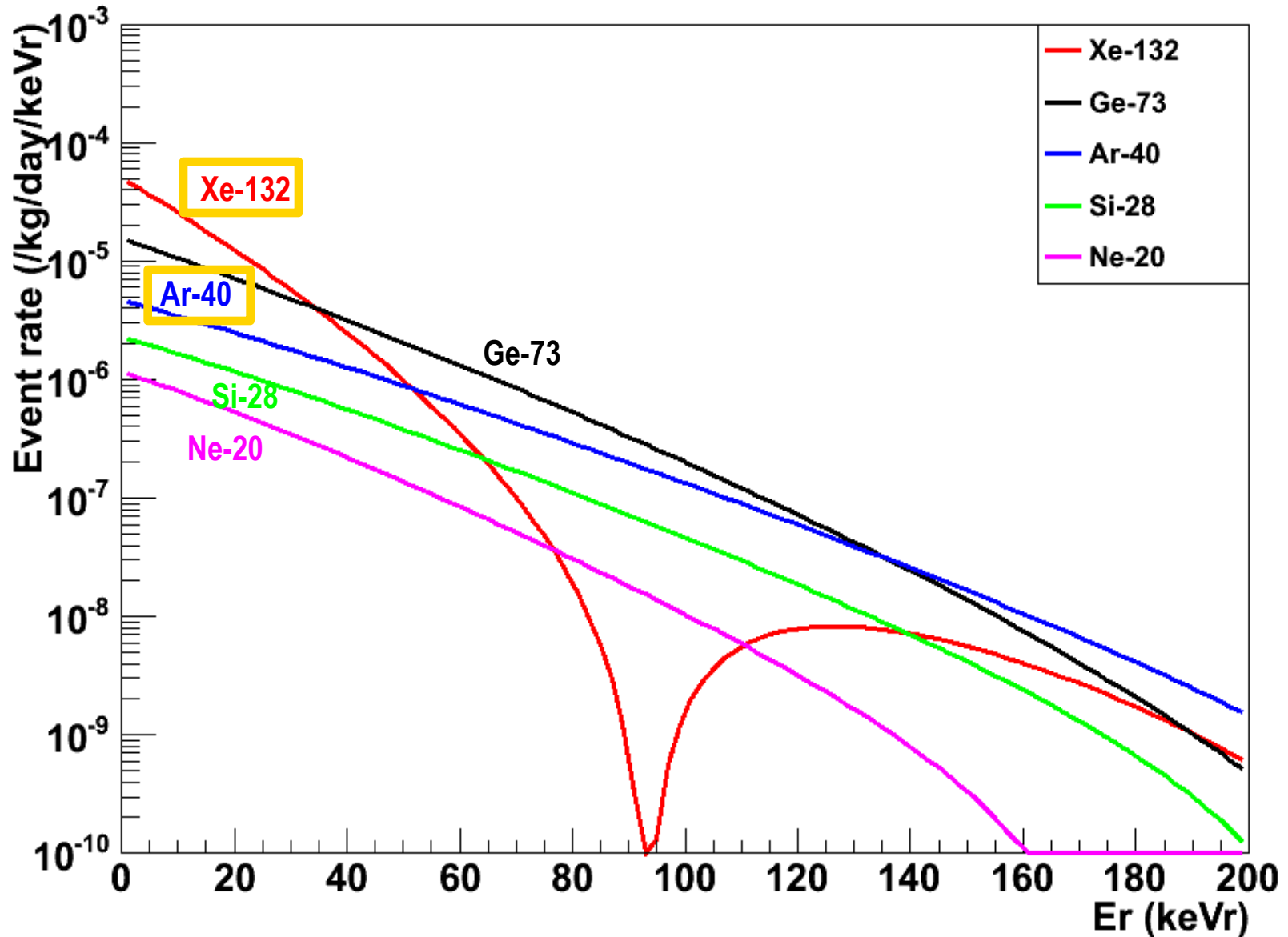

(SI) WIMP Energy Spectrum for LXe (Cross Section = 10^{-45}cm^2)

(SI) WIMP Recoil Energy Spectrum for LXe ($\sigma = 10^{-45} \text{cm}^2$)

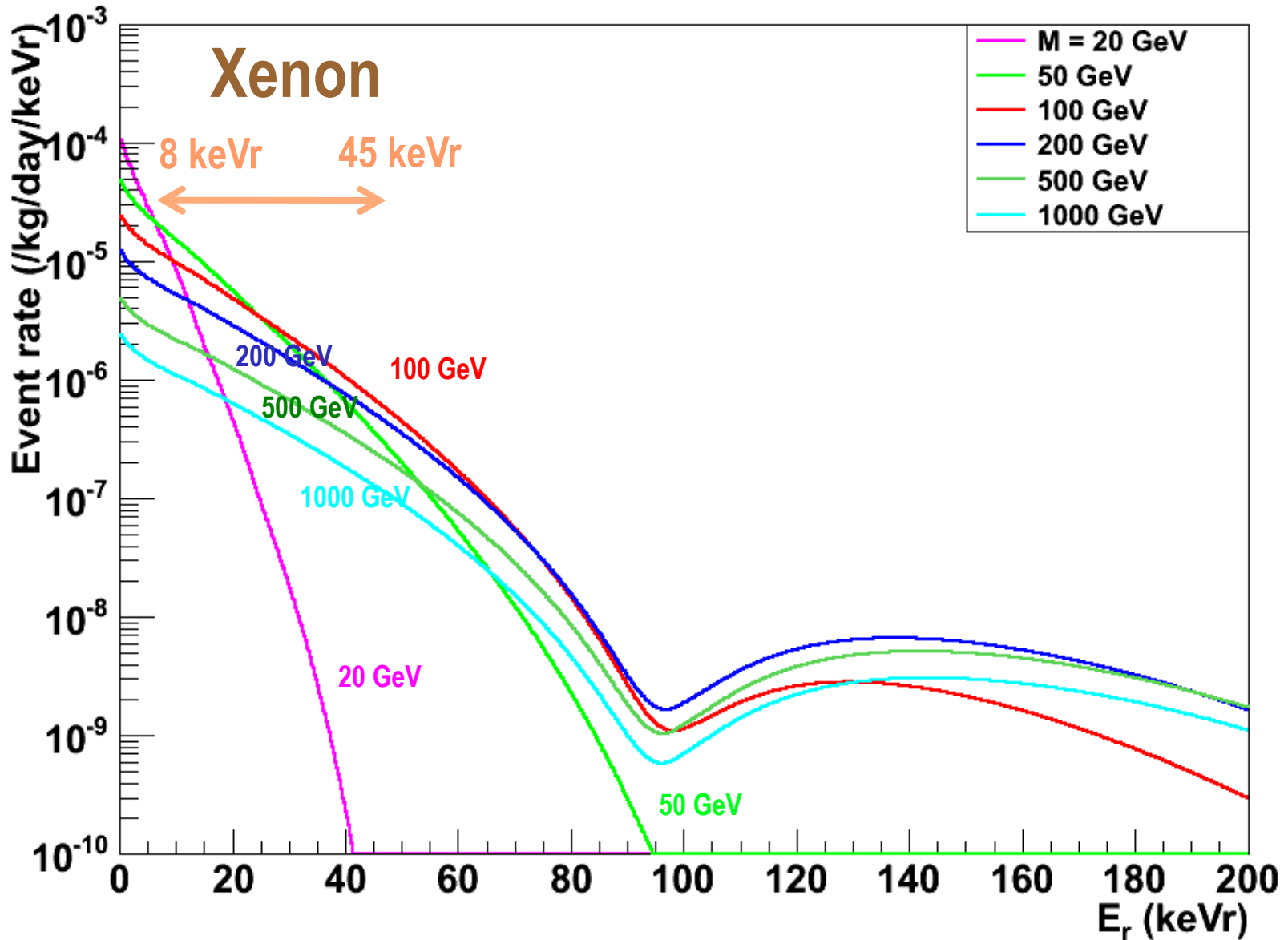

(SI) WIMP Energy Spectrum for LAr (Cross Section = 10^{-45}cm^2)

(SI) WIMP Recoil Energy Spectrum for LAr ($\sigma = 10^{-45} \text{cm}^2$)

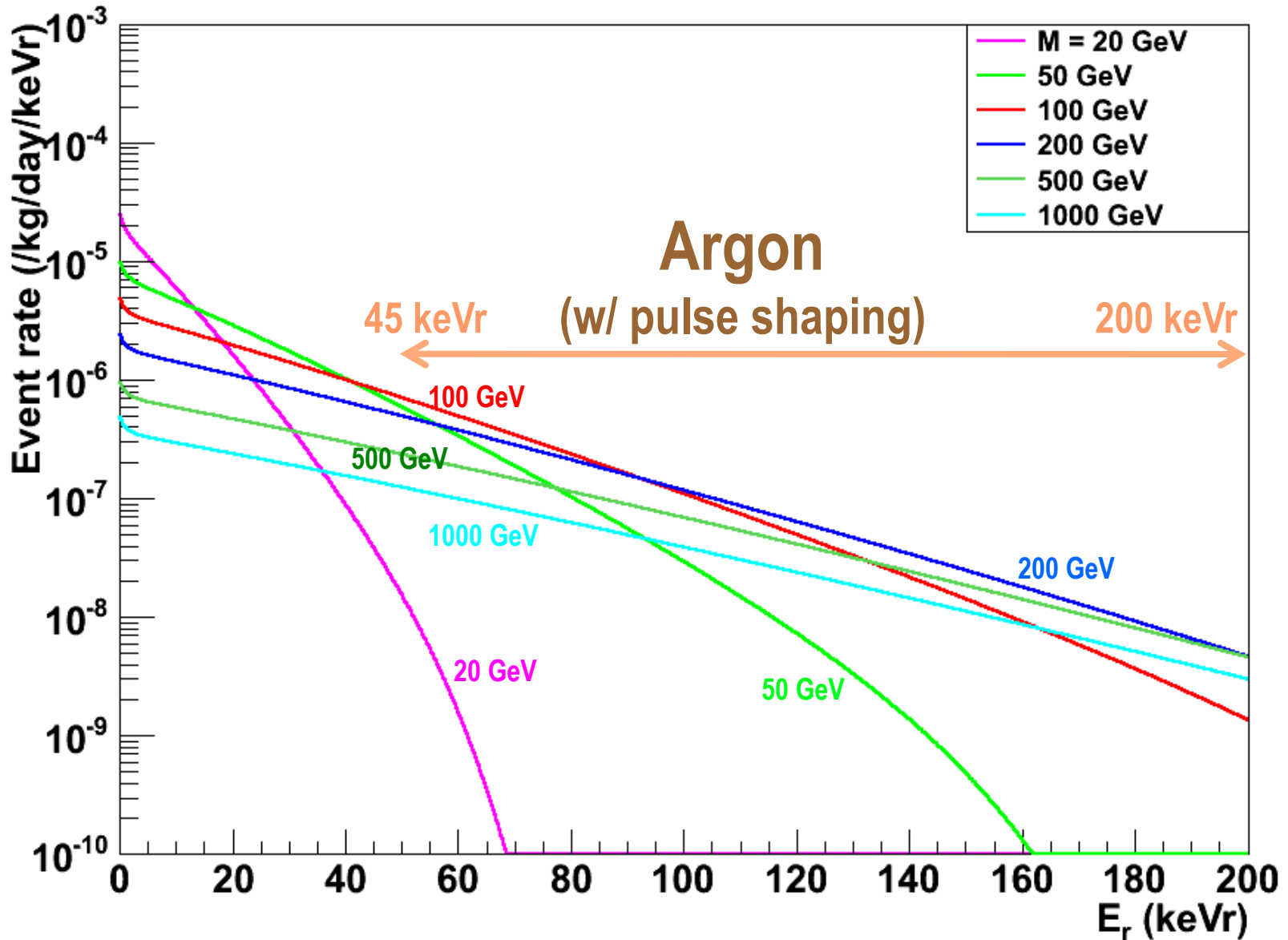

1- σ Error of WIMP Mass vs SI Cross Section (10 ton*year Xe and 50 ton*year Ar)

1- σ Error of WIMP Mass and SI Cross Section

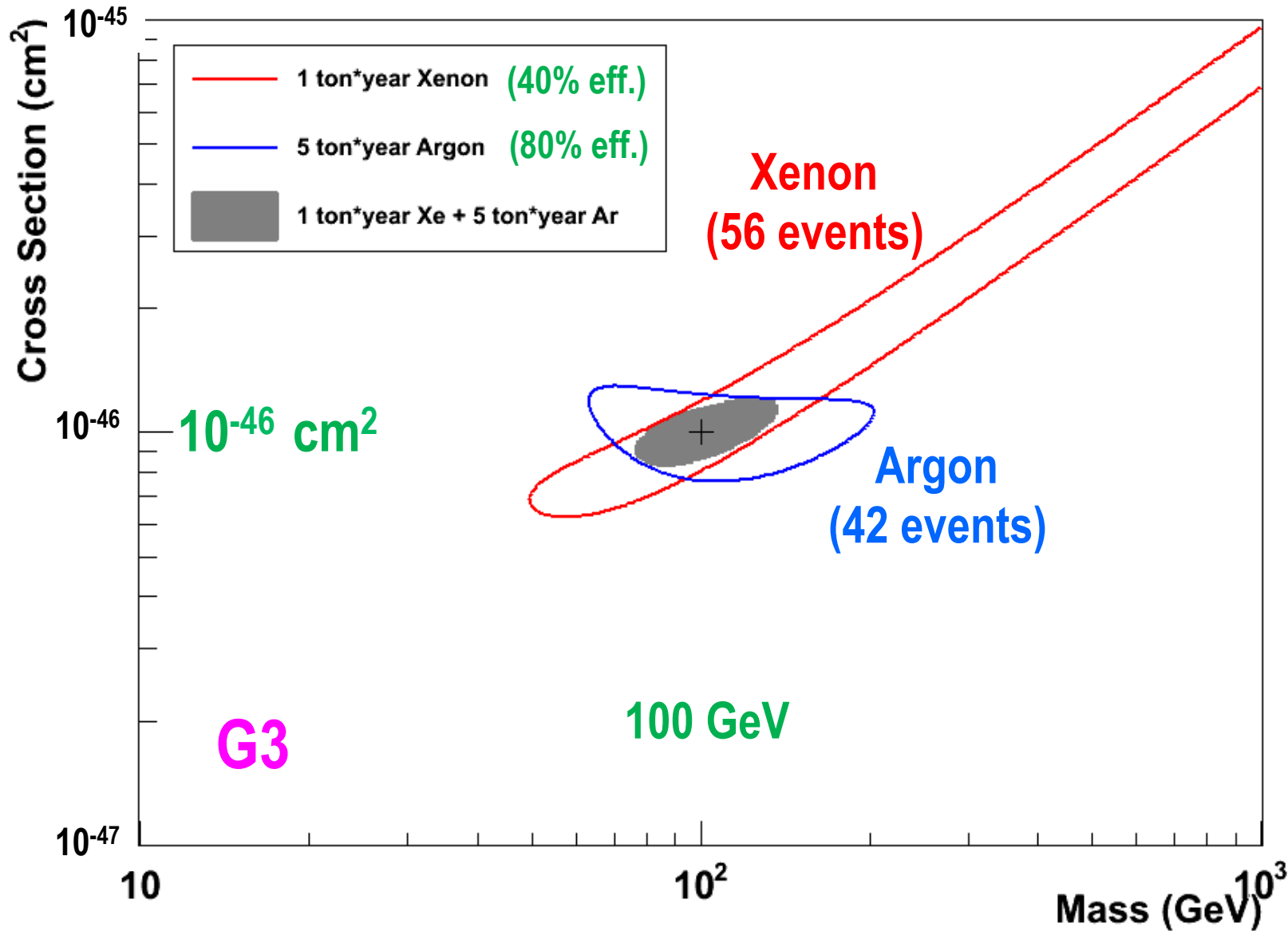

1- σ Error of WIMP Mass vs SI Cross Section (10 ton*year Xe and 50 ton*year Ar)

1- σ Error of WIMP Mass and SI Cross Section

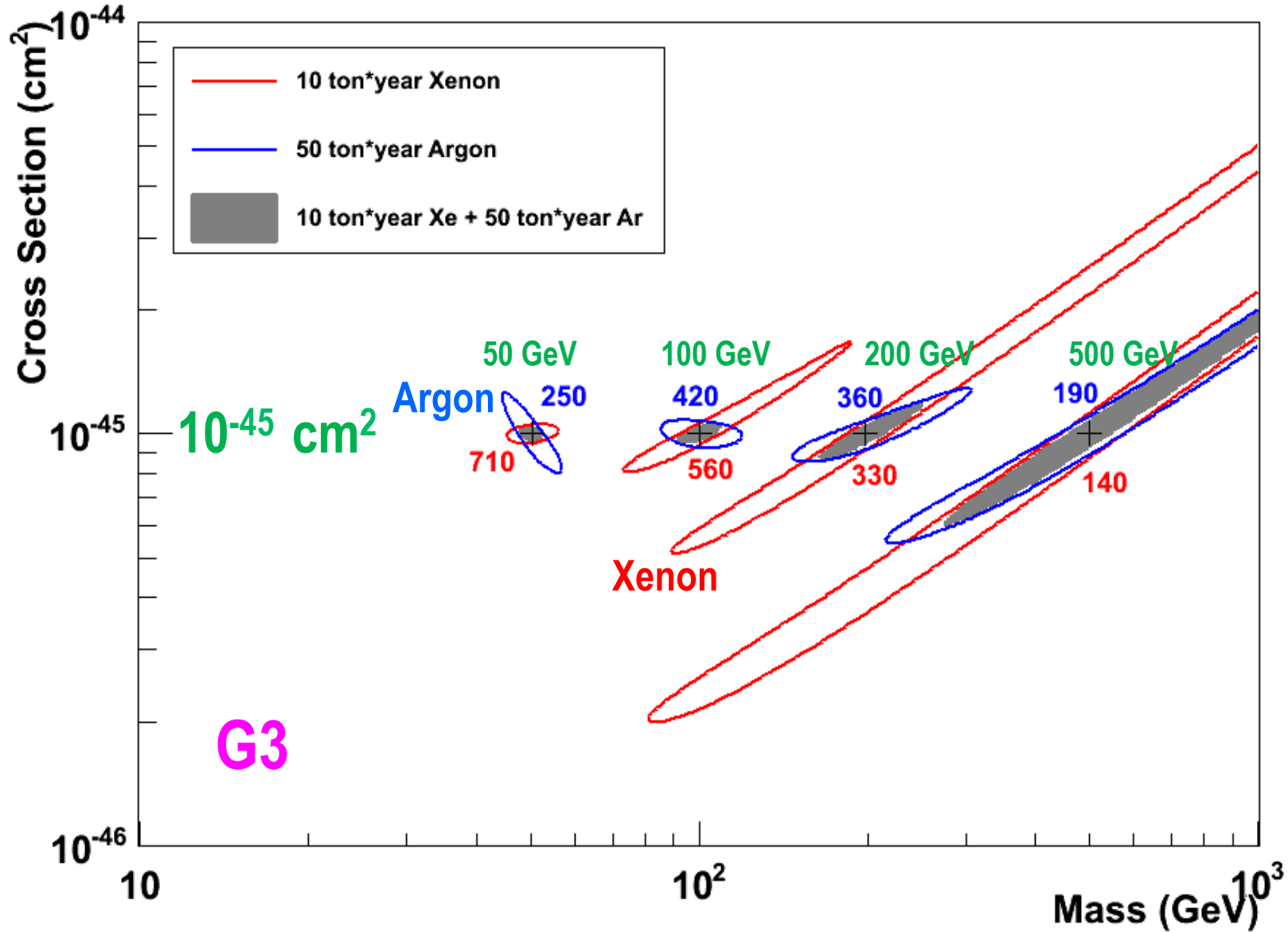

(SI) WIMP Energy Spectrum for LXe (Cross Section = 10^{-45}cm^2)

(SI) WIMP Recoil Energy Spectrum for LXe ($\sigma = 10^{-45} \text{cm}^2$)

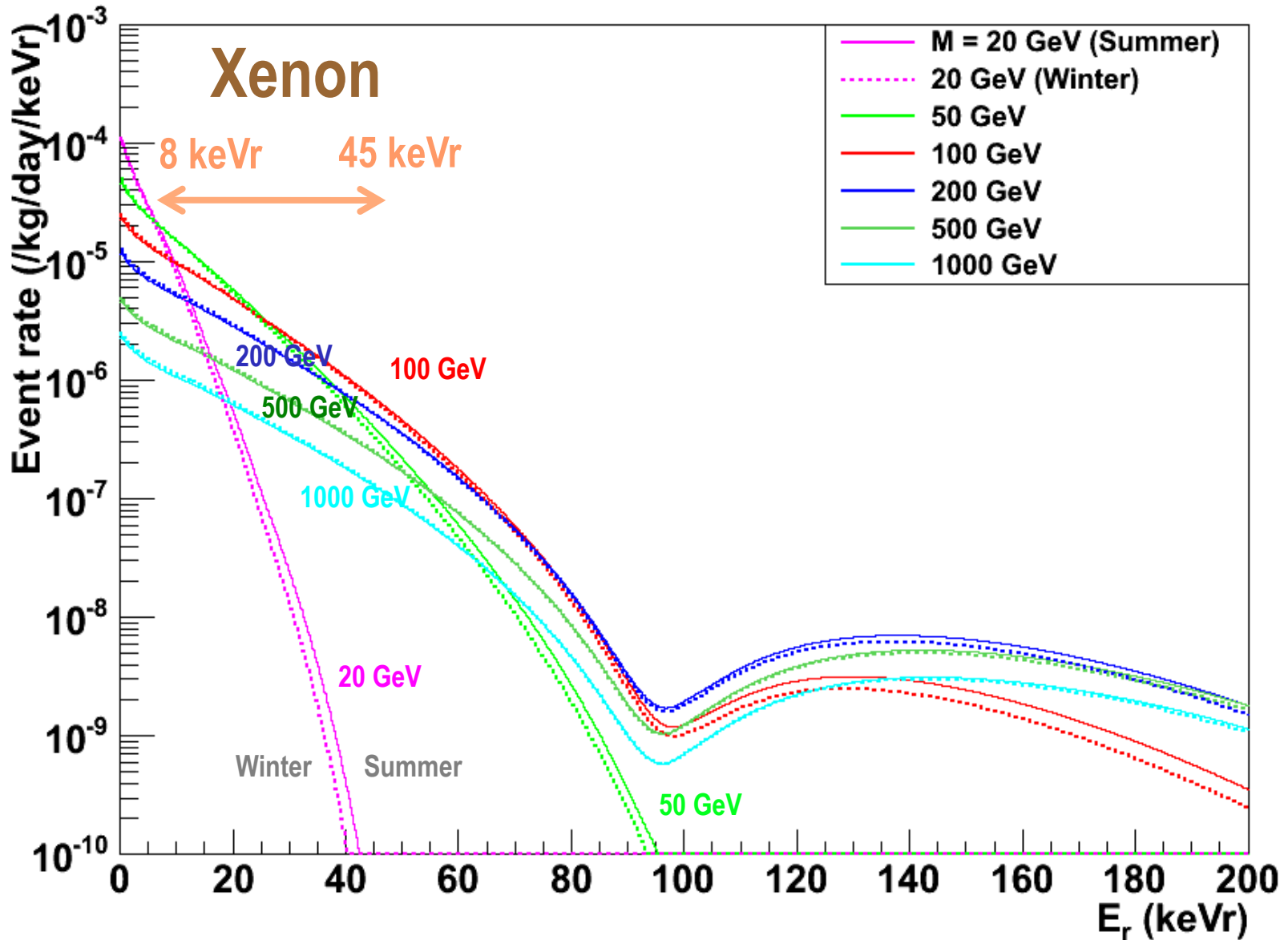

(SI) WIMP Energy Spectrum for LAr (Cross Section = 10^{-45}cm^2)

(SI) WIMP Recoil Energy Spectrum for LAr ($\sigma = 10^{-45} \text{cm}^2$)

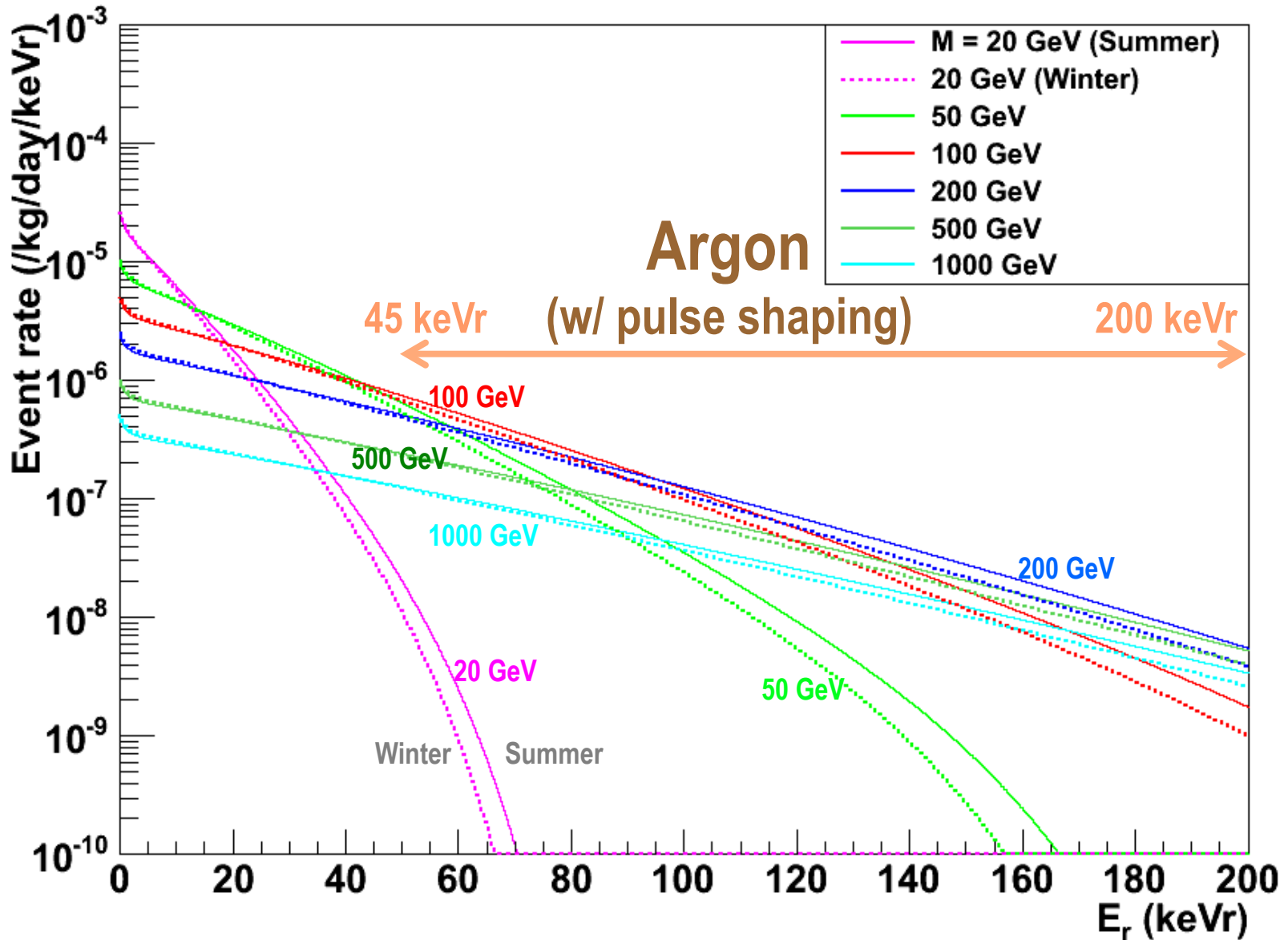

$\pm 1 \sigma$ Error of Annual Modulation Amplitude vs WIMP Mass (10 ton*year Xe and 50 ton*year Ar, Cross Section = 10^{-45}cm^2)

1-Sigma Error of Annual Modulation Amplitude vs WIMP Mass ($\sigma = 1\text{E-}45\text{cm}^2$)

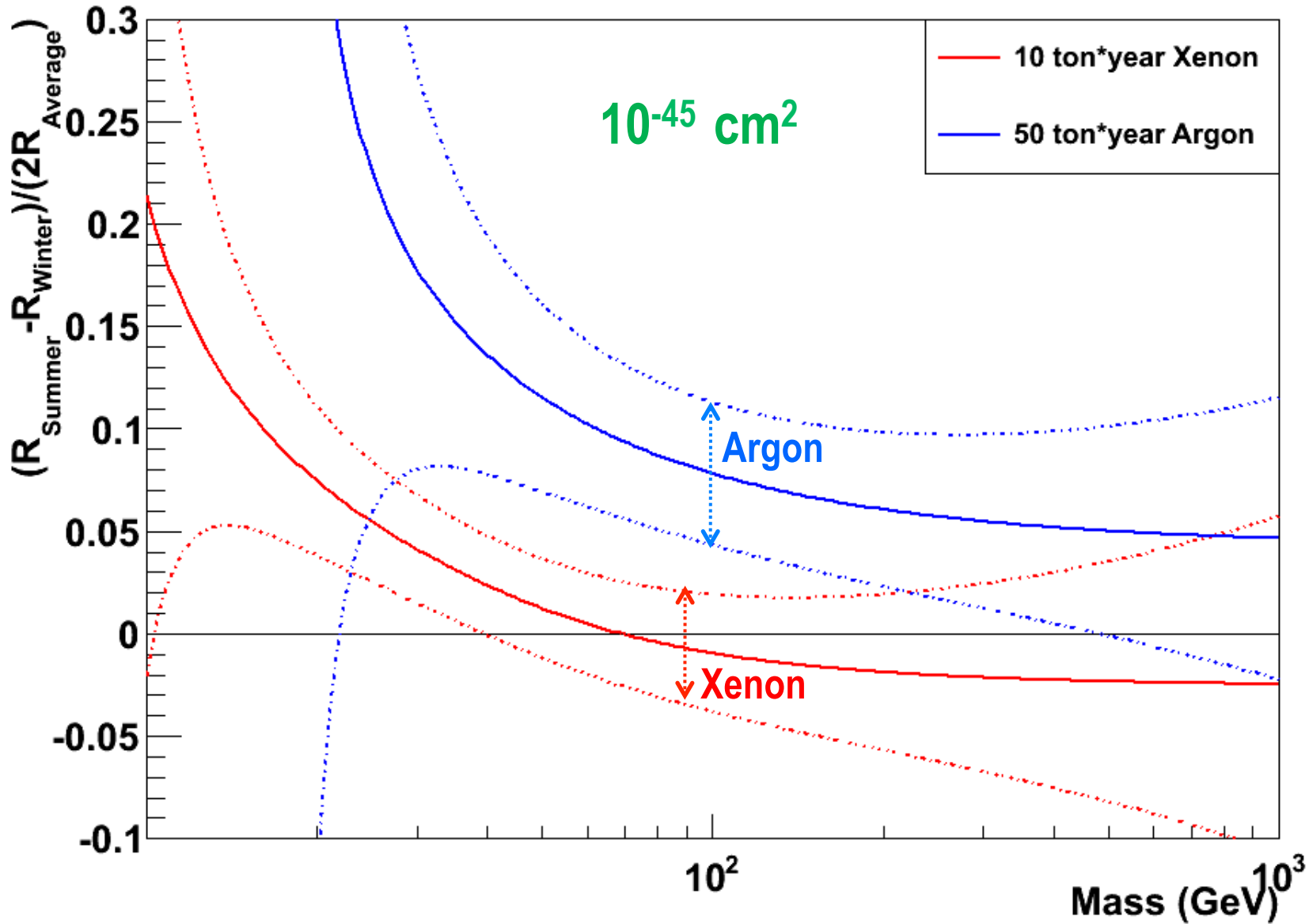

$\pm 1 \sigma$ Error of Annual Modulation Amplitude vs WIMP Mass (10 ton*year Xe and 50 ton*year Ar, Cross Section = 10^{-44}cm^2)

1-Sigma Error of Annual Modulation Amplitude vs WIMP Mass ($\sigma = 1\text{E-}44\text{cm}^2$)

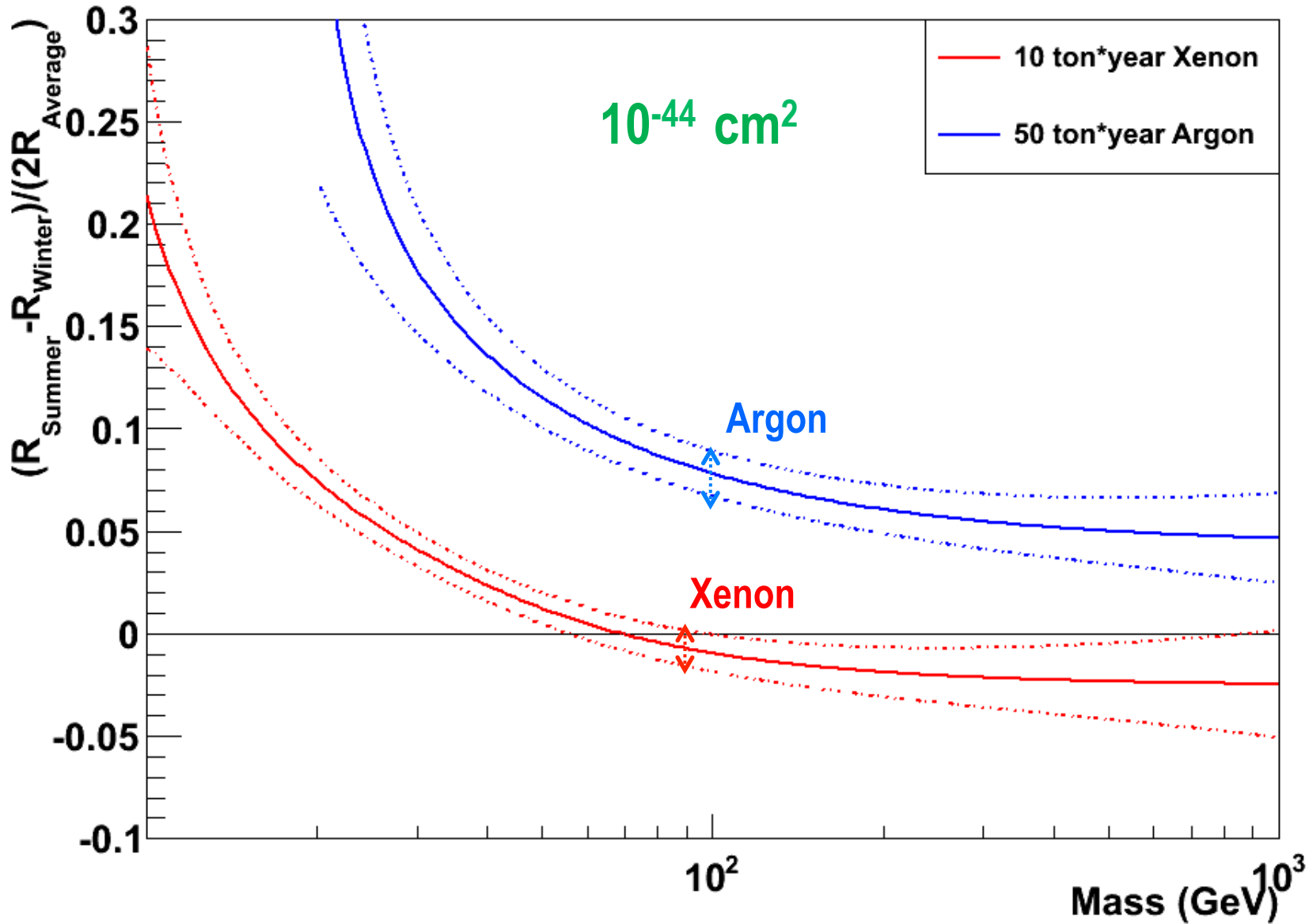

$\pm 1 \sigma$ Error of Annual Modulation Amplitude for various WIMP velocities (50 ton*year Ar, Cross Section = 10^{-44}cm^2)

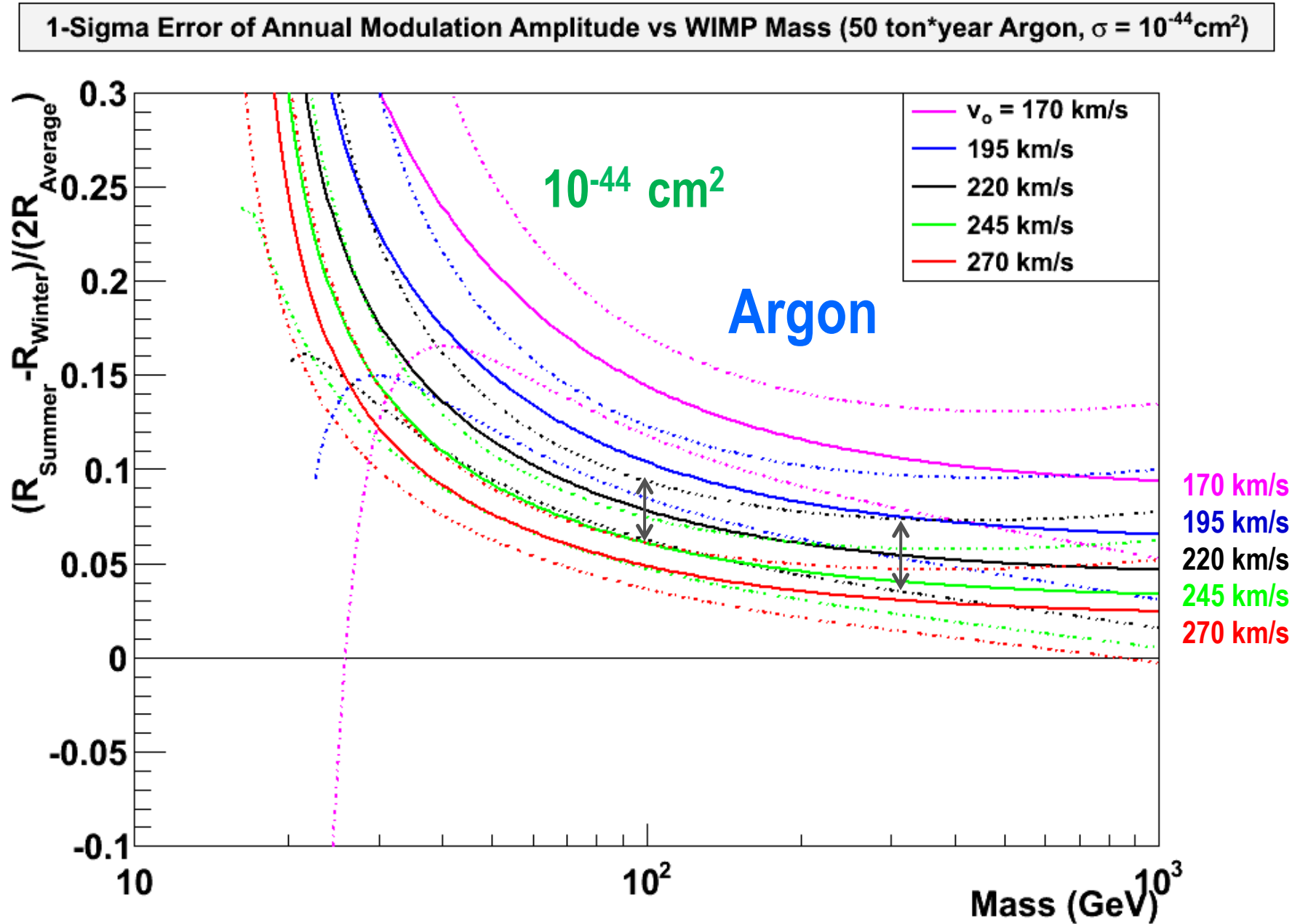

Expected Background from Gammas and pp Solar Neutrinos (100 Year, Multi-hit Cut, S2/S1 Cut)

pp Solar Neutrino and QUPID Gamma Background (100 years, multi-hit cut, S2/S1 cut)

pp Solar Neutrino and QUPID Gamma Background (multi-hit cut, S2/S1 cut)

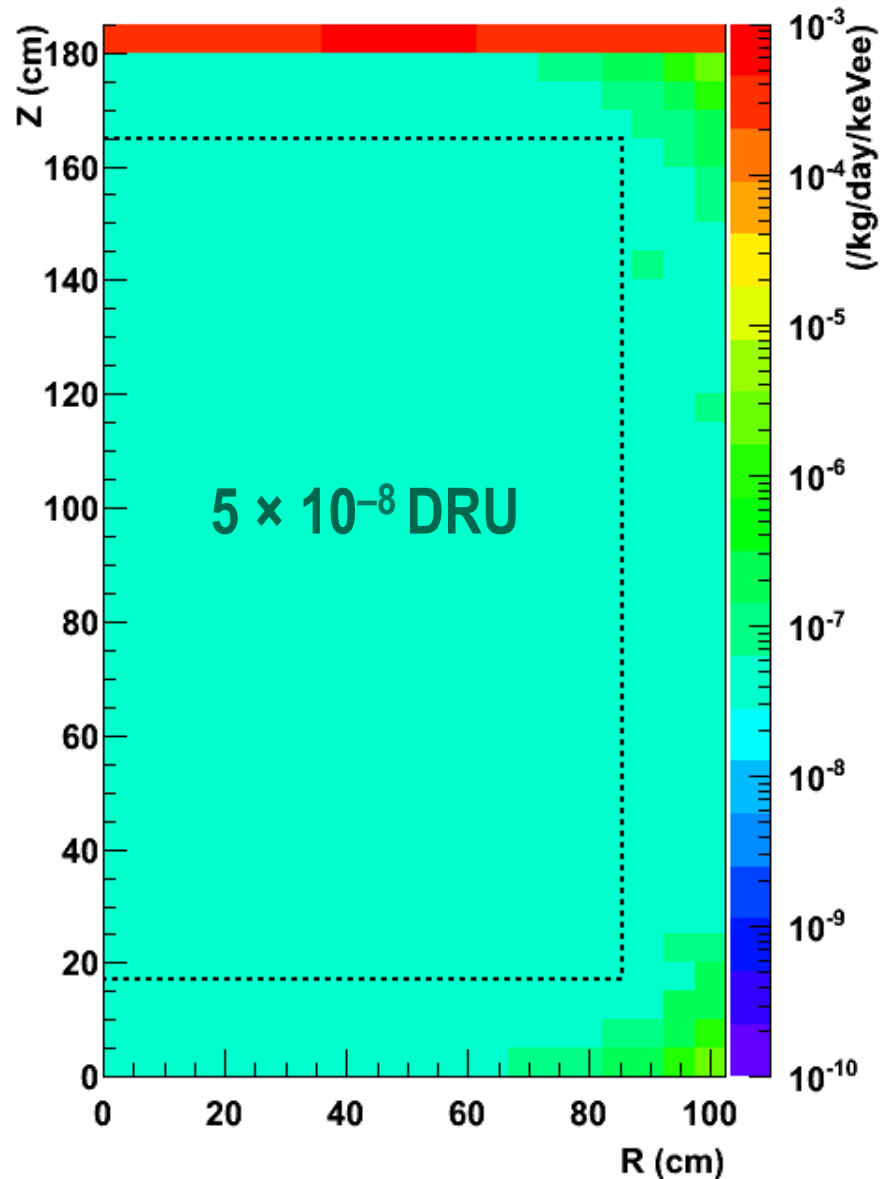
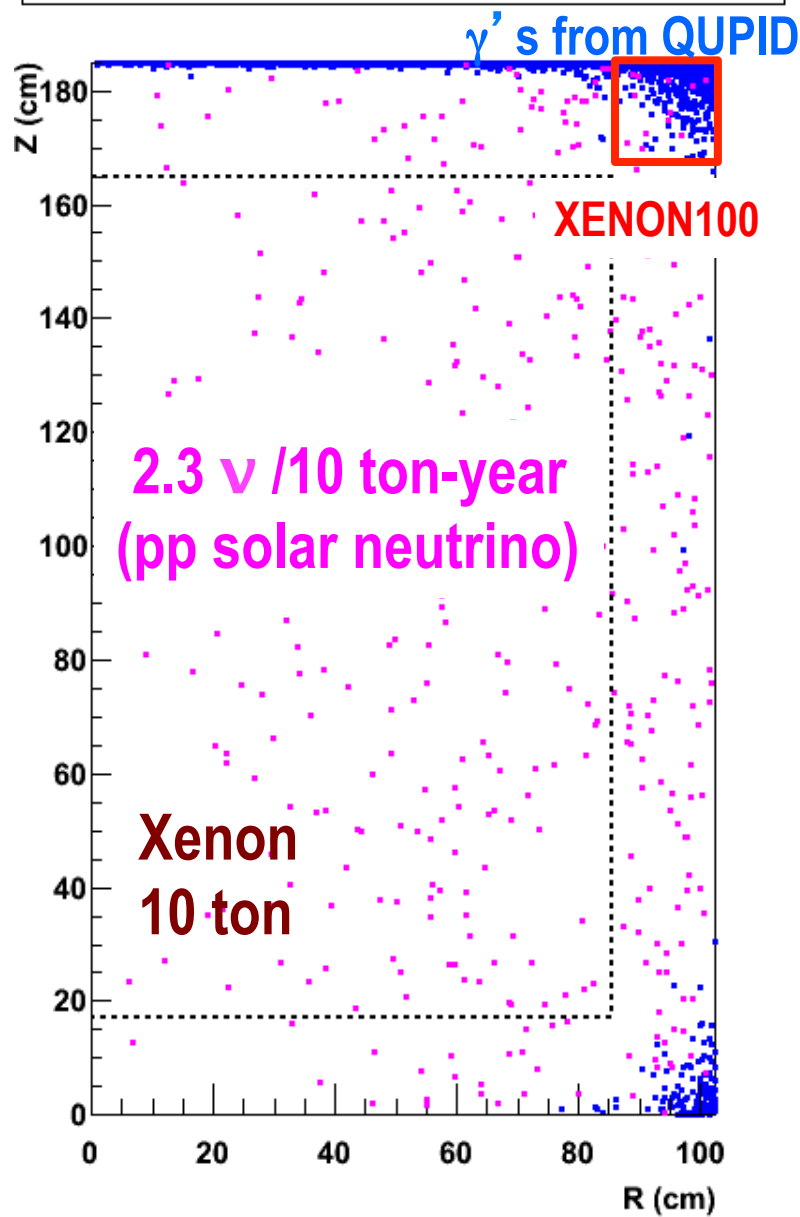

Xe 10 ton Neutron Background (100 Years)

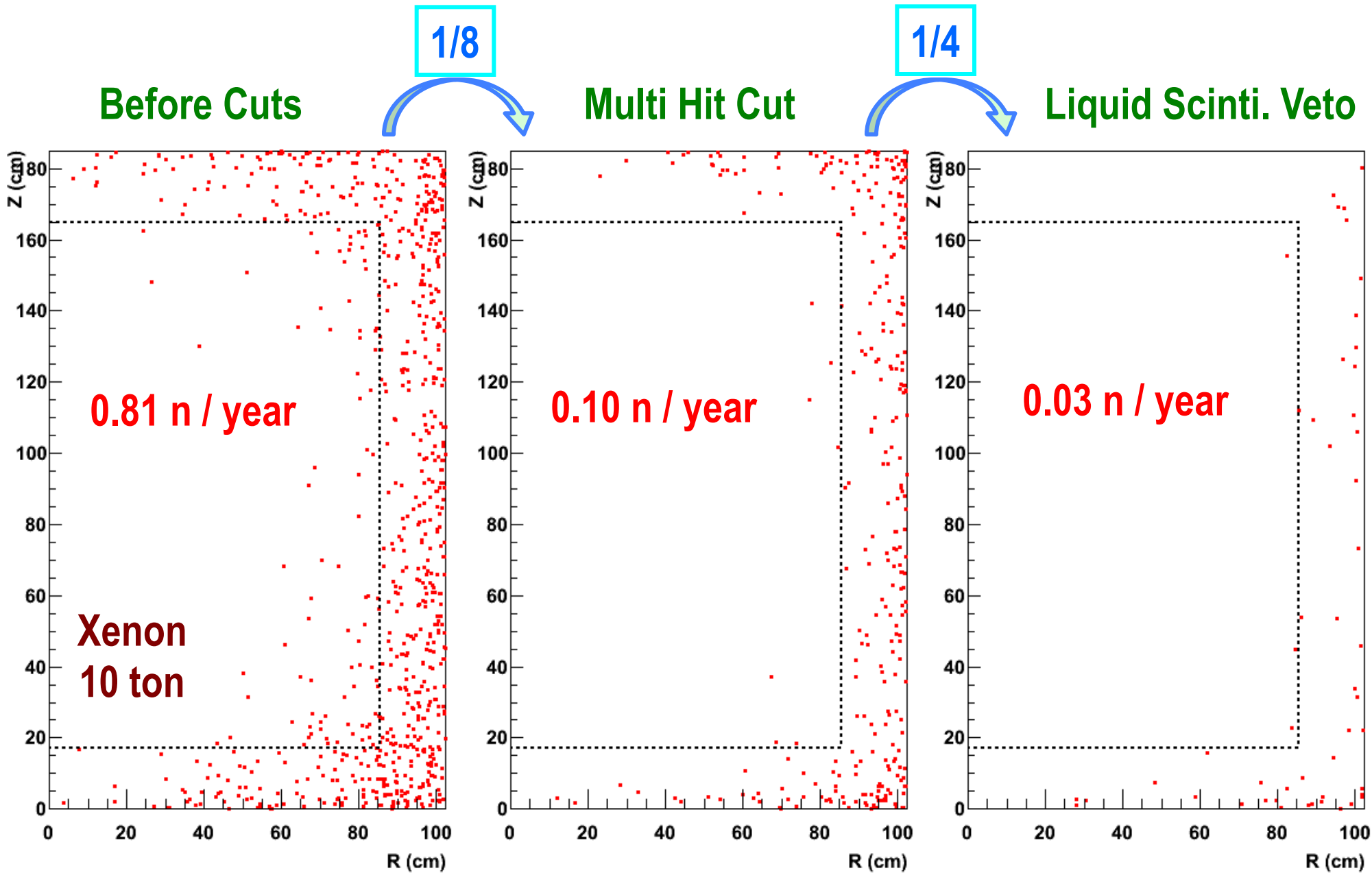

Ar 50 ton Neutron Background (100 Years)

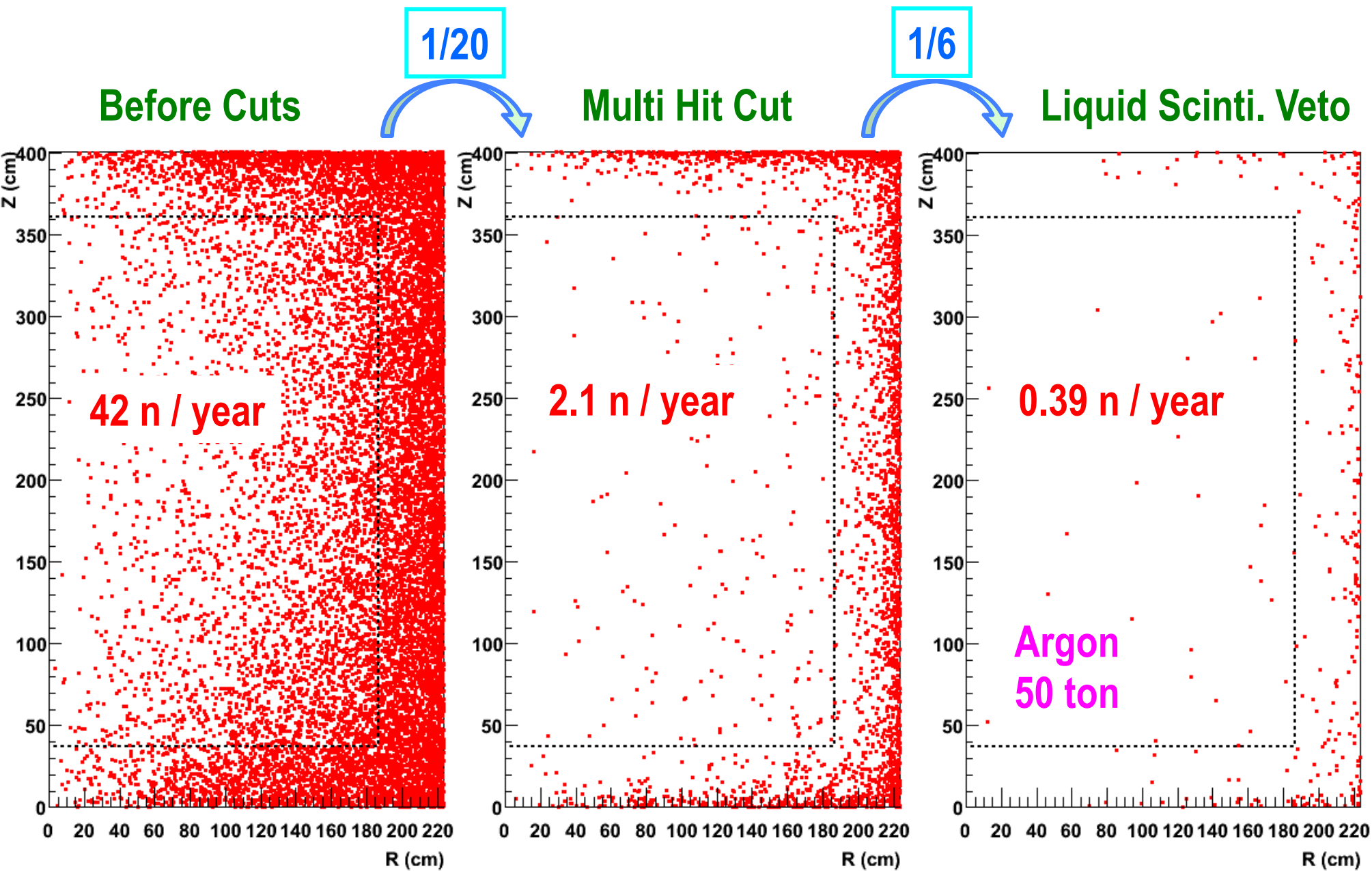

Summary of MAX G2/G3 & XAX

	MAX G2		MAX G3		XAX	
	Xenon	Argon	Xenon	Argon	$^{129/131}\text{Xe}$	^{136}Xe (80%)
Dimension						
<i>Detector Size</i>	1m x 1m	2m x 2m	2m x 2m	4m x 4m	2m x 2m	
<i>Total Mass</i>	2.2 ton	10 ton	20 ton	70 ton	13 ton	7 ton
<i>Fiducial Mass</i>	1.1 ton	5 ton	10 ton	50 ton	6 ton	4 ton
QUPID						
<i>Top</i>	121 (3")	595 (3")	595 (3")	661 (6")	595 (3")	
<i>Side</i>	0	672 (6")	672 (6")	2423 (6")	672 (6")	
<i>Bottom</i>	121 (3")	163 (6")	163 (6")	661 (6")	163 (6")	
No.WIMP / year (10^{-45} cm^2)						
<i>Mass = 20 GeV</i>	23	–	230	–	138	92
<i>50 GeV</i>	71	25	710	250	426	284
<i>100 GeV</i>	56	42	560	420	336	224
<i>200 GeV</i>	33	36	330	360	198	132
<i>500 GeV</i>	14	19	140	190	84	56
Backgrounds / year						
<i>Gammas</i>	0.07	0.00	0.01	0.00	0.07	0.01
<i>Neutrons (w/o LS)</i>	0.10	0.78	0.10	2.1	0.10	0.00
<i>Neutrons (w/ LS)</i>	0.03	0.10	0.03	0.39	0.03	0.00
Neutrinos / year						
<i>0ν DBD (10^{27} yr)</i>	0.4	–	3.3	–	–	30
<i>pp-solar</i>	–	–	–	–	2500	–
<i>Supernova (10 kpc)</i>	11	14	95	141	56	39

Conclusions

- **XENON100 running extremely well.**
 - Already comparable sensitivity as XENON10 and CDMS-II in 10 days (30 kg fiducial).
 - Background is 100 times lower than XENON10.
 - By September, > 10 times larger exposure than CDMS-II.
- **QUPID successfully developed.**
 - The first signals in Liquid Xenon.
 - Mass production (6 QUPID/day) almost ready.
- **Based on QUPID, the future multi-ton Xe/Ar detectors designed and proposed.**
 - XENON 1ton and DarkSide 50 at Gran Sasso.
 - MAX G3 (Xe 10 ton + Ar 50 ton) at DUSEL.

90% CL Limits of SI Cross Section

