

Exploring the Origin of Life and Consciousness by Ultra high-speed Microscopes

Katsushi Arisaka

***University of California, Los Angeles
Department of Physics and Astronomy***



Why are we here?

The Origin of Universe

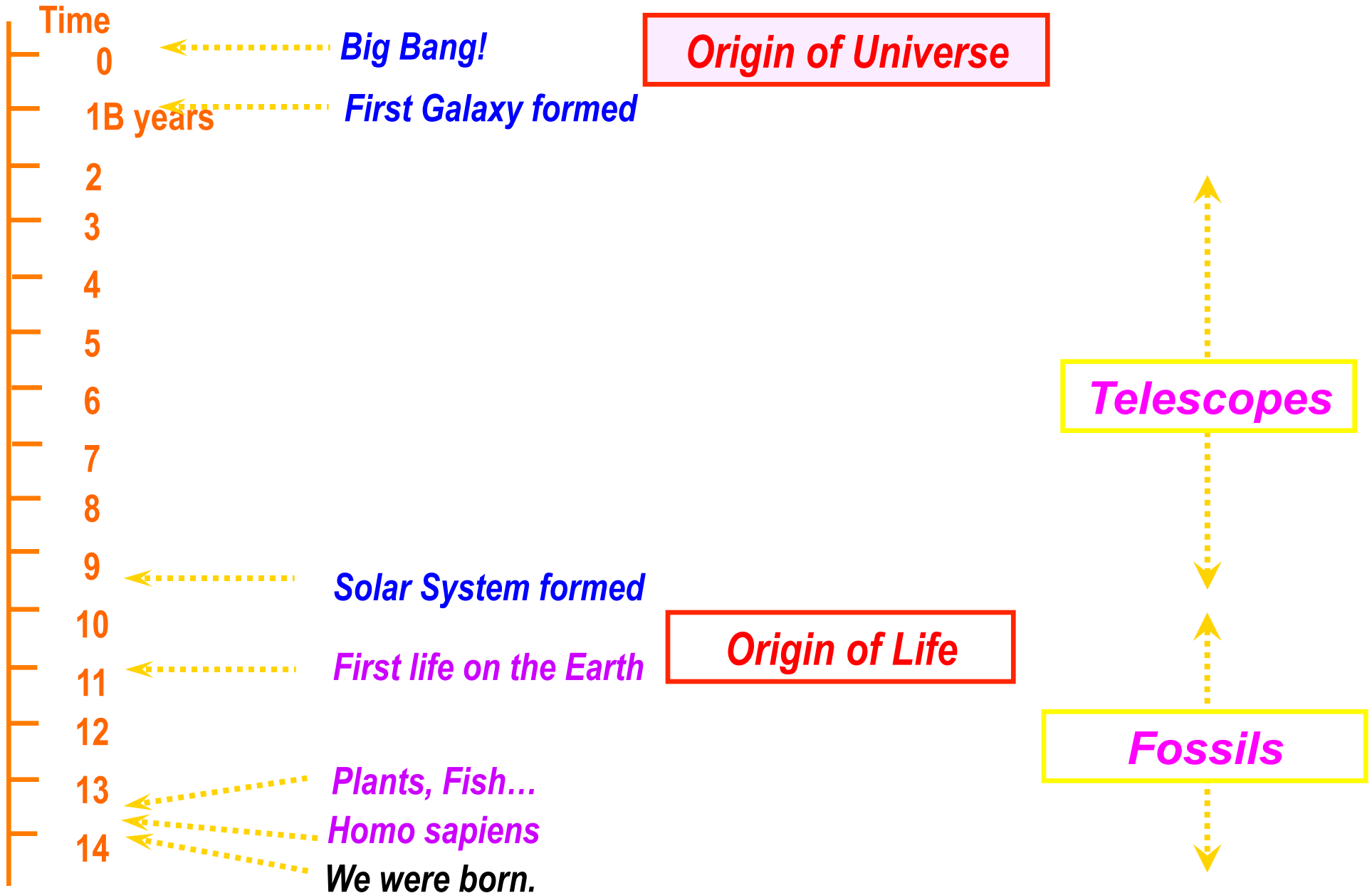

Brief History of Universe and Life

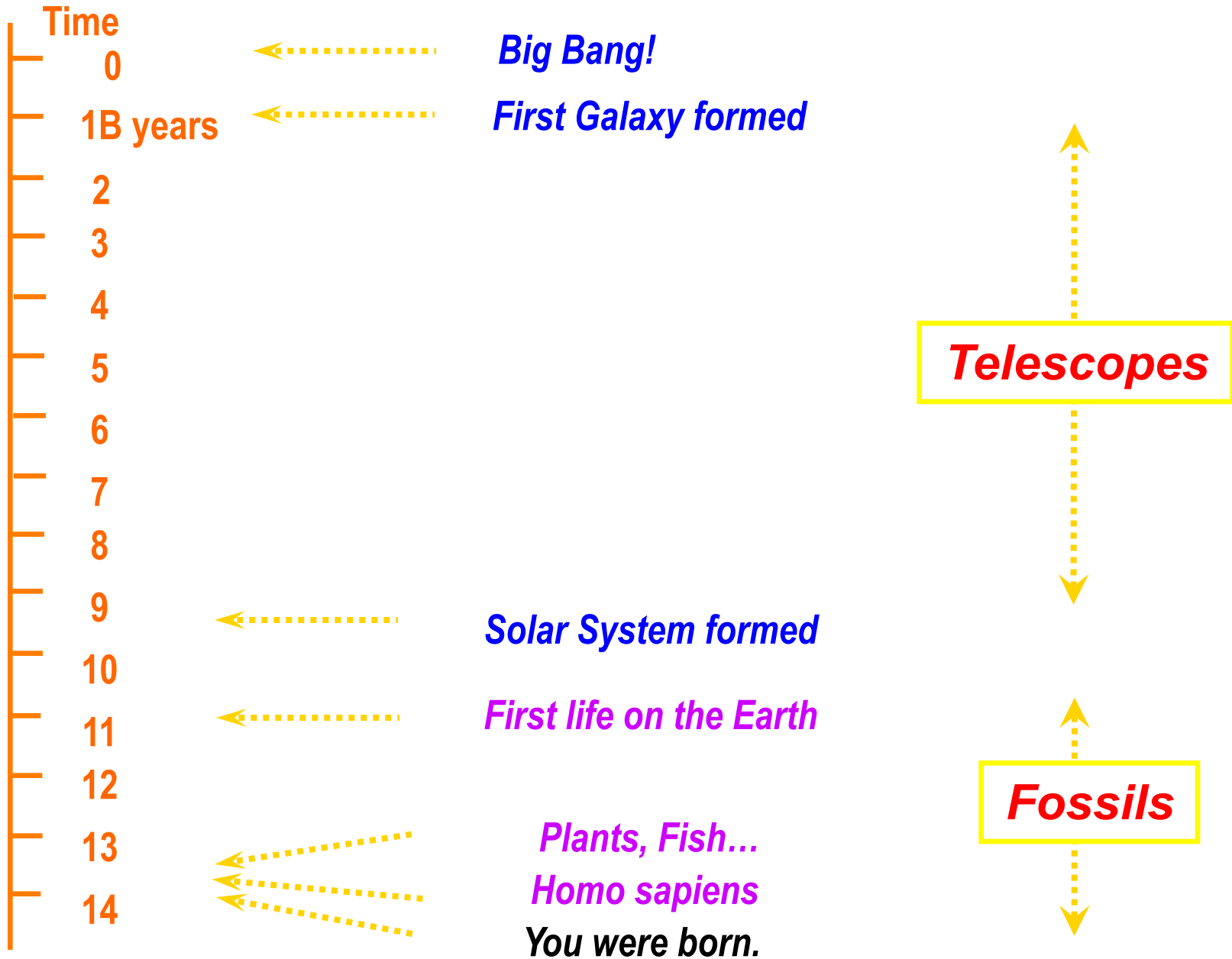



~100 Billions Stars in a Galaxy

**ANDROMEDA
GALAXY.**

Hubble Deep Field

The image displays a dense field of galaxies, including various types such as spirals, ellipticals, and irregular shapes, scattered across a dark background. The galaxies are concentrated in the central and lower-left regions, with some appearing as bright, distinct points of light and others as faint, diffuse structures. The overall appearance is that of a rich, multi-colored stellar population.

~100 Billion Galaxies

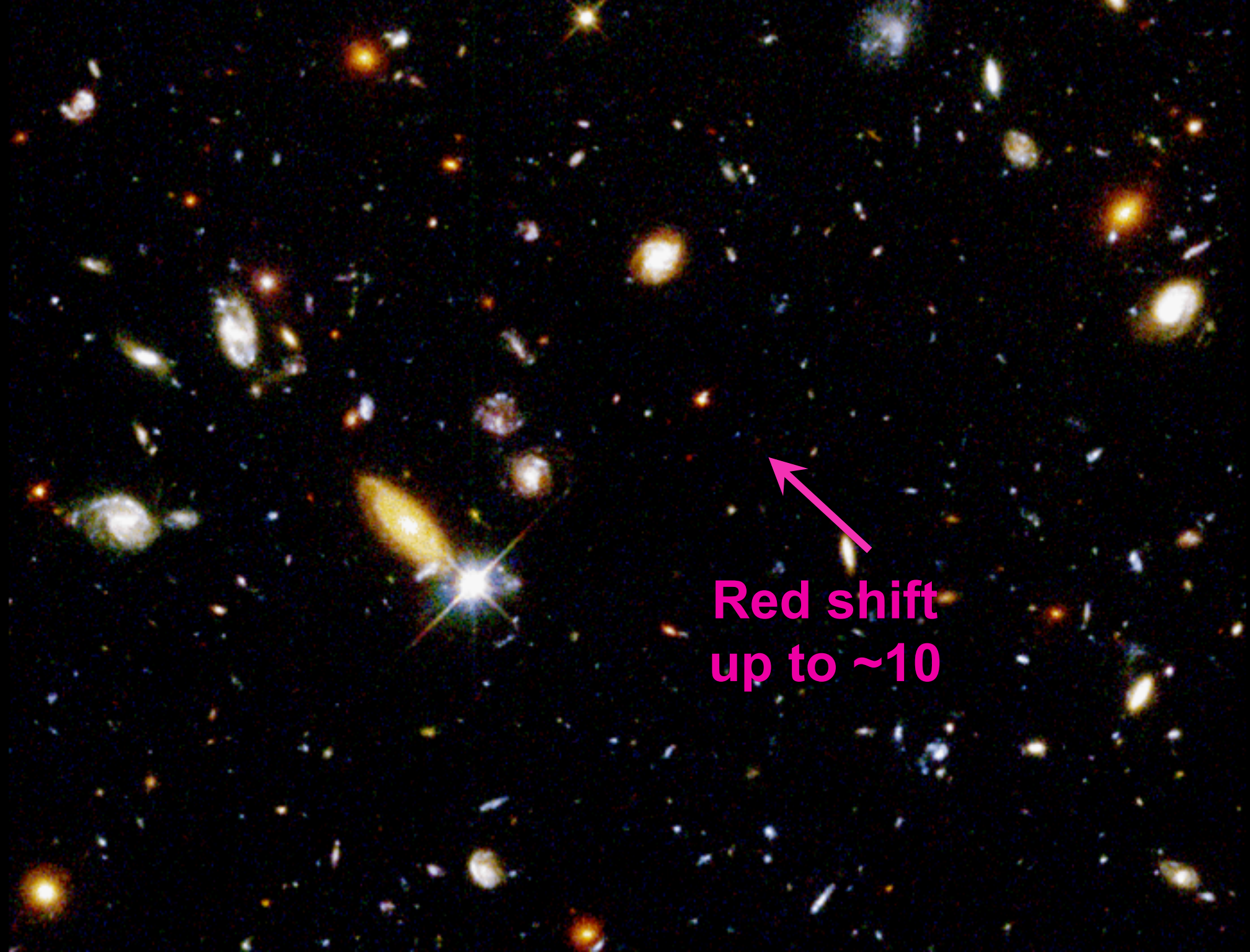

**Red shift
up to ~10**

Hubble's Law: Expansion of the Universe

Big Bang!

Horizon
of Universe

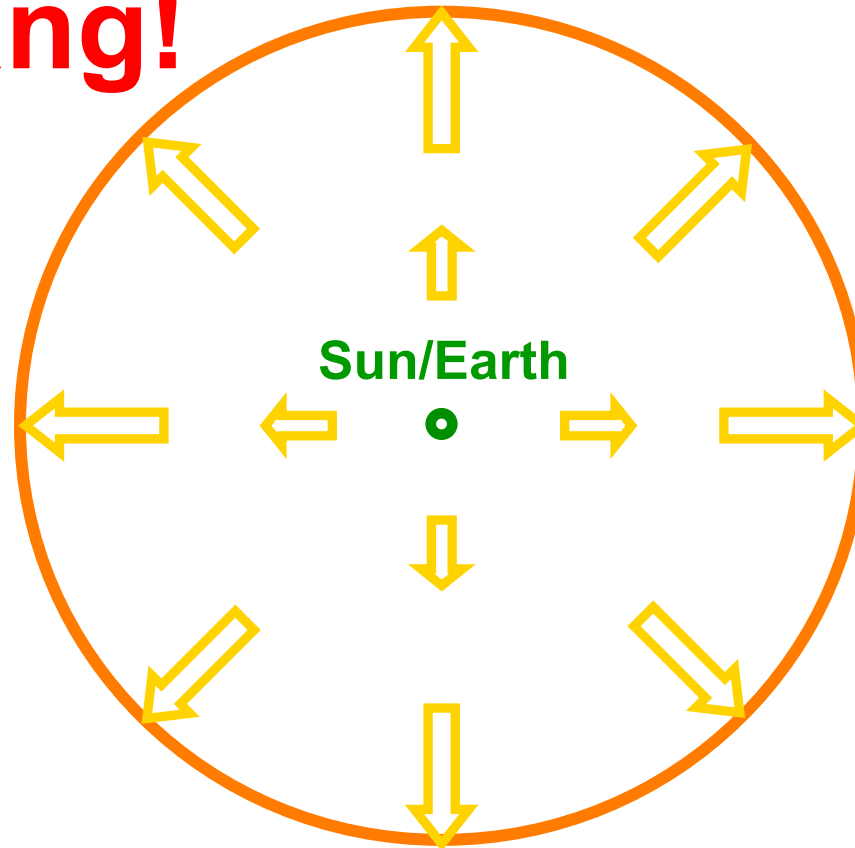

14 Billion
Light Years

Moving Away
at Speed of Light

The Origin of Universe and Particles

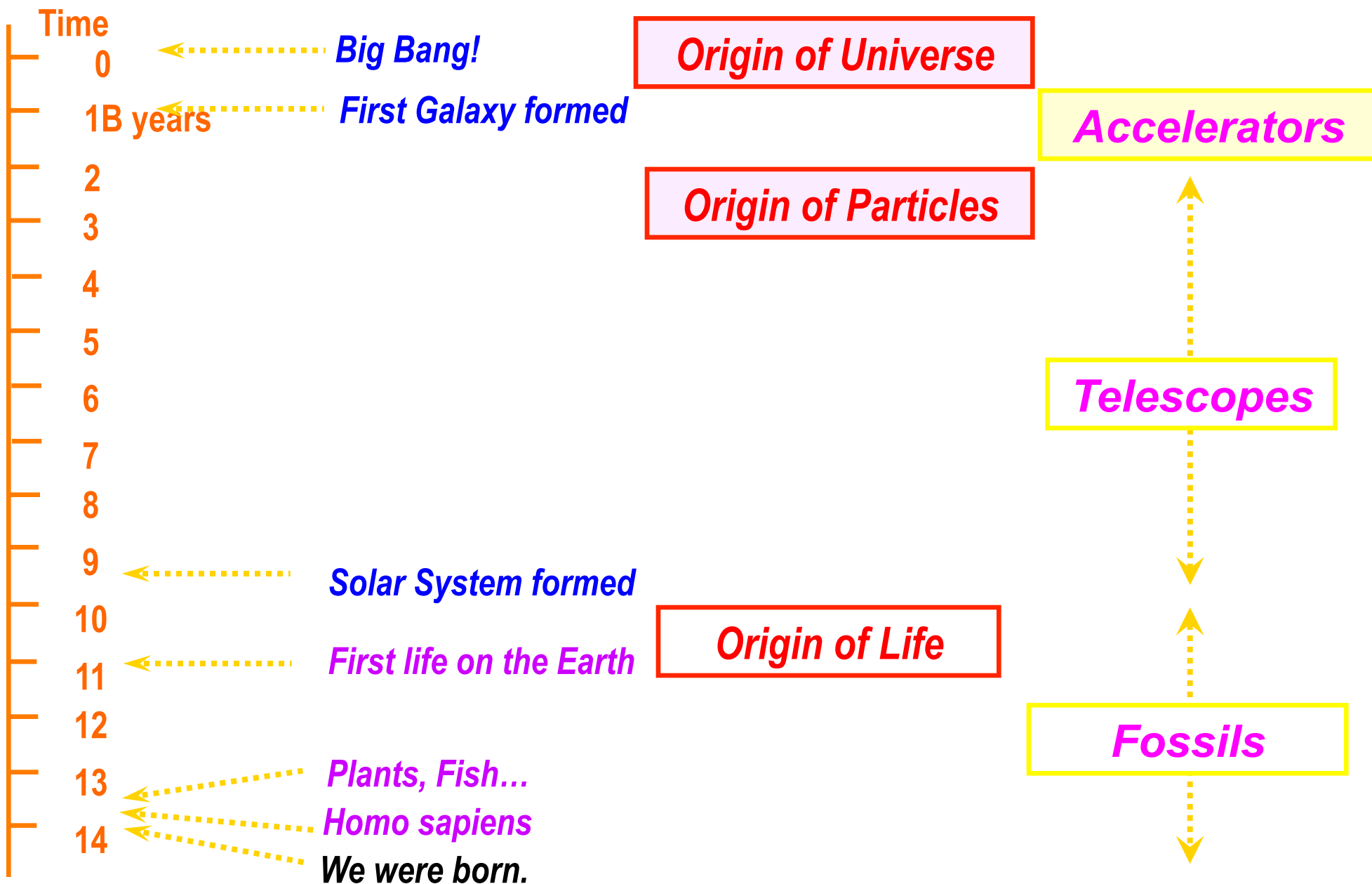

Fermi Lab near Chicago



6km Circumference
1+1=2 TeV

Elementary Particles

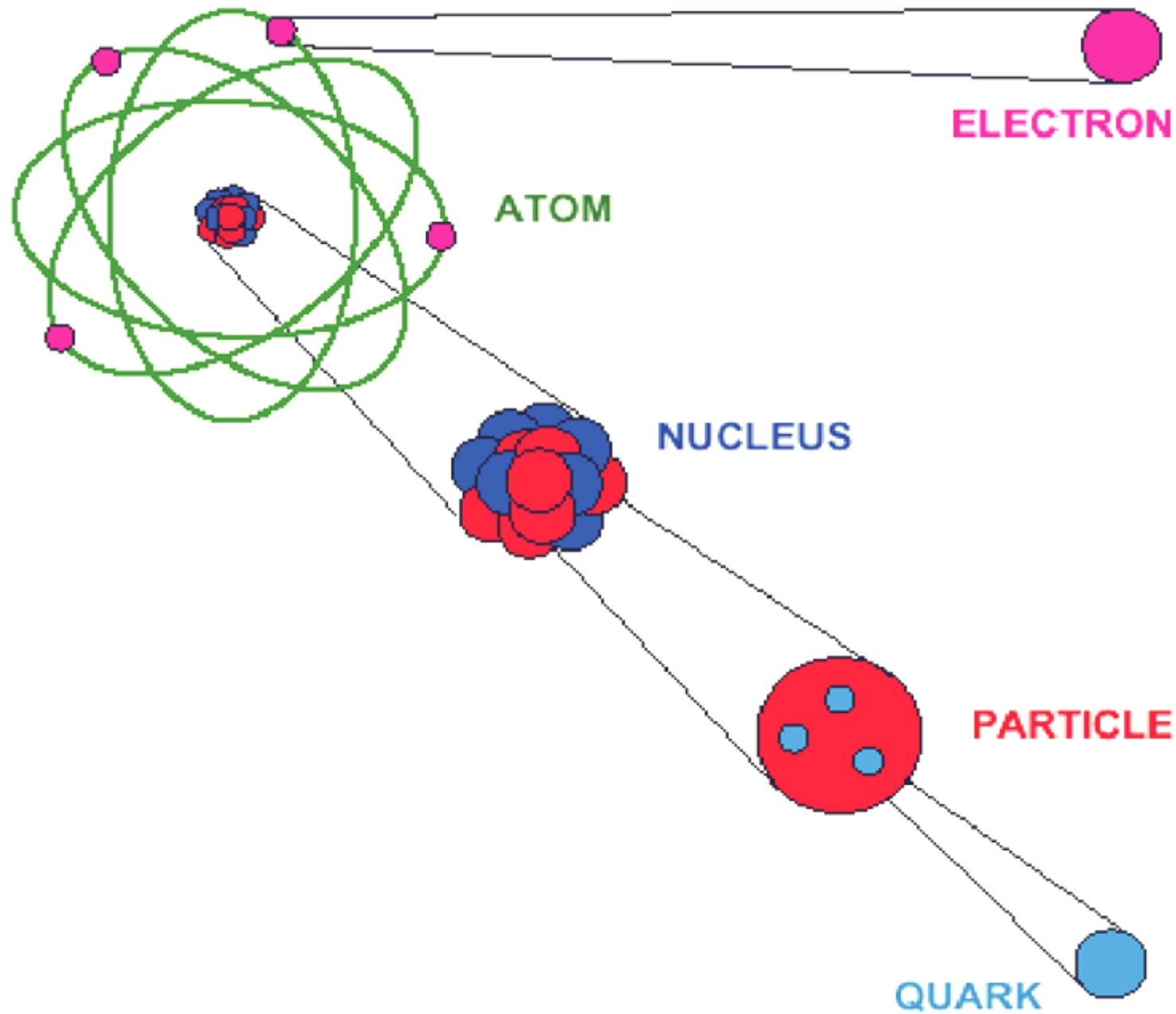

Unification of Forces

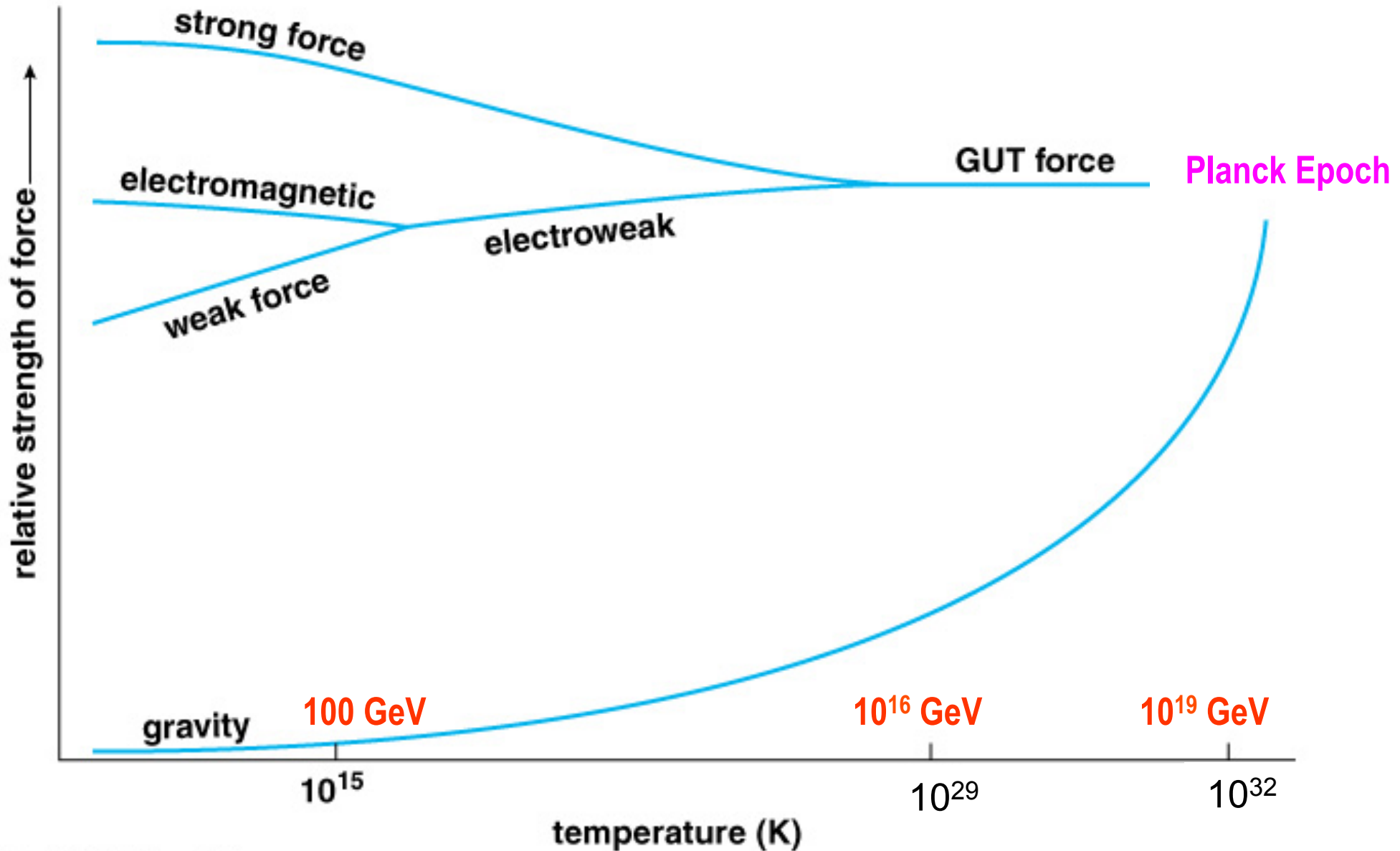

Copyright © Addison Wesley.

Physicists' View of Early Universe

Lorentz Invariance
Local Gauge Invariance

Structure of DNA

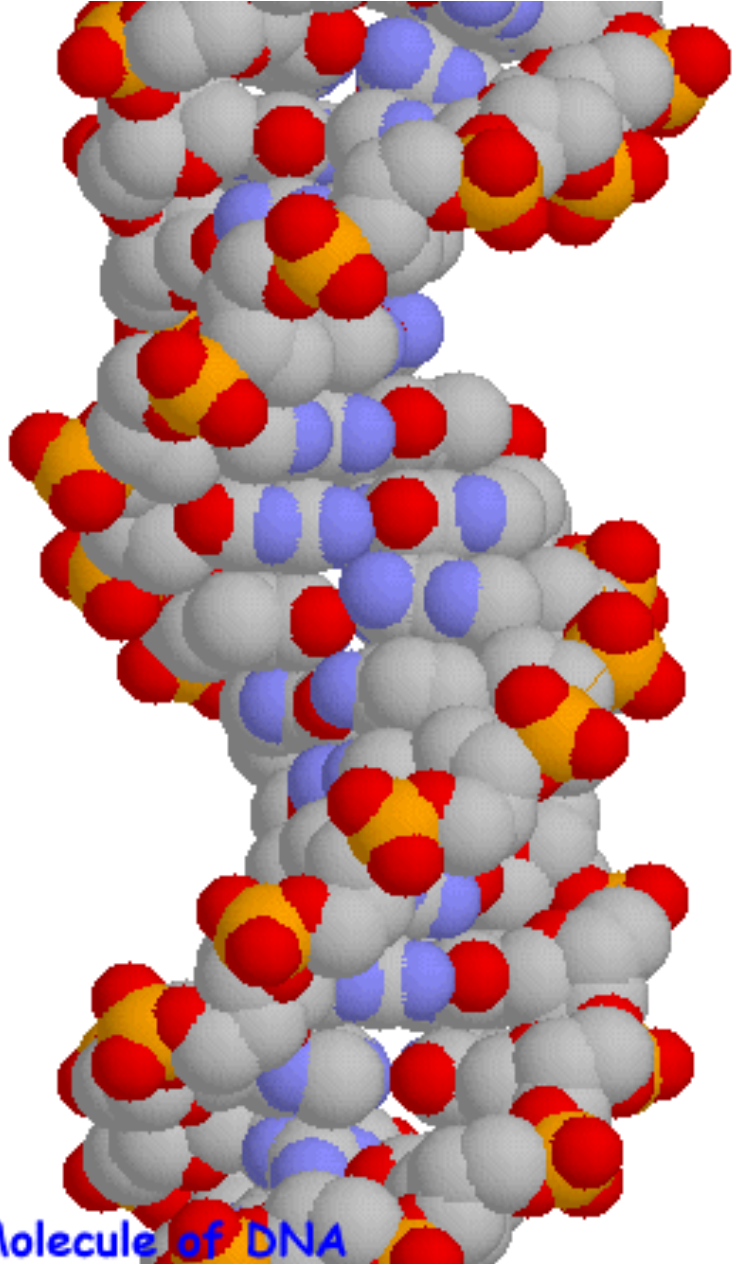

©Rothamsted Experimental Station, 1997, 1998

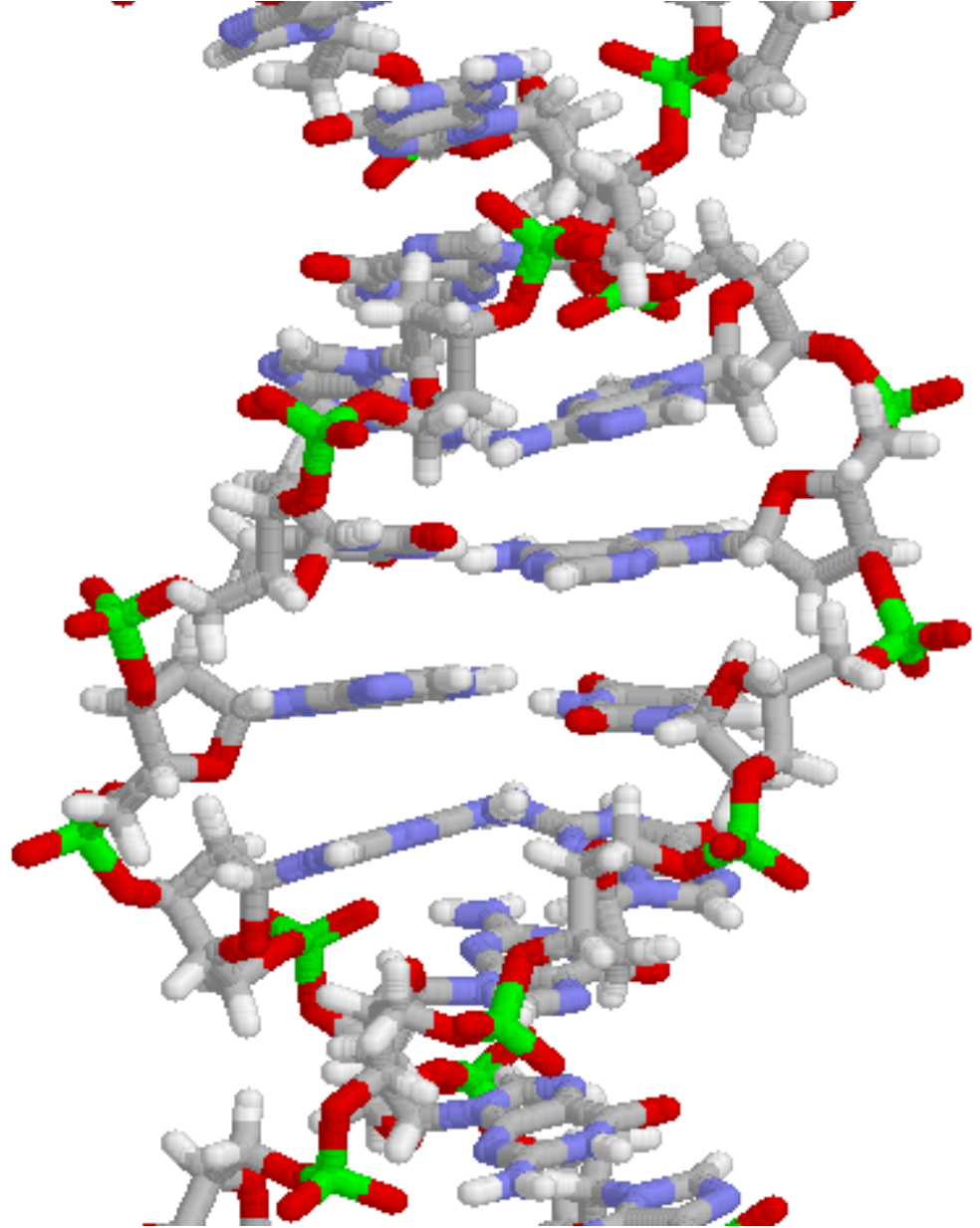

Molecule of DNA

Symmetry Breaking



Simple

*Symmetry
Break Down*

Complex

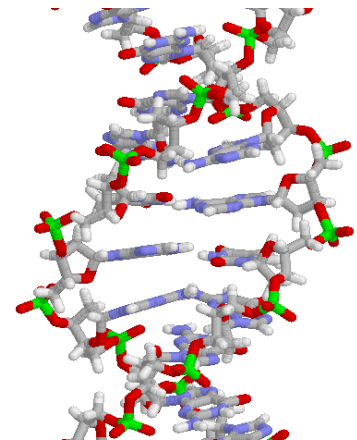
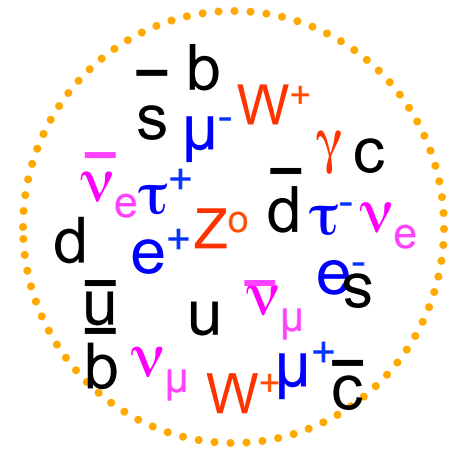

The Beginning

- Everything was the same \leftrightarrow Perfect symmetry.
 - All the particles are the same as photons.
 - All four forces are the same.
- The Universe was 10 dimension.

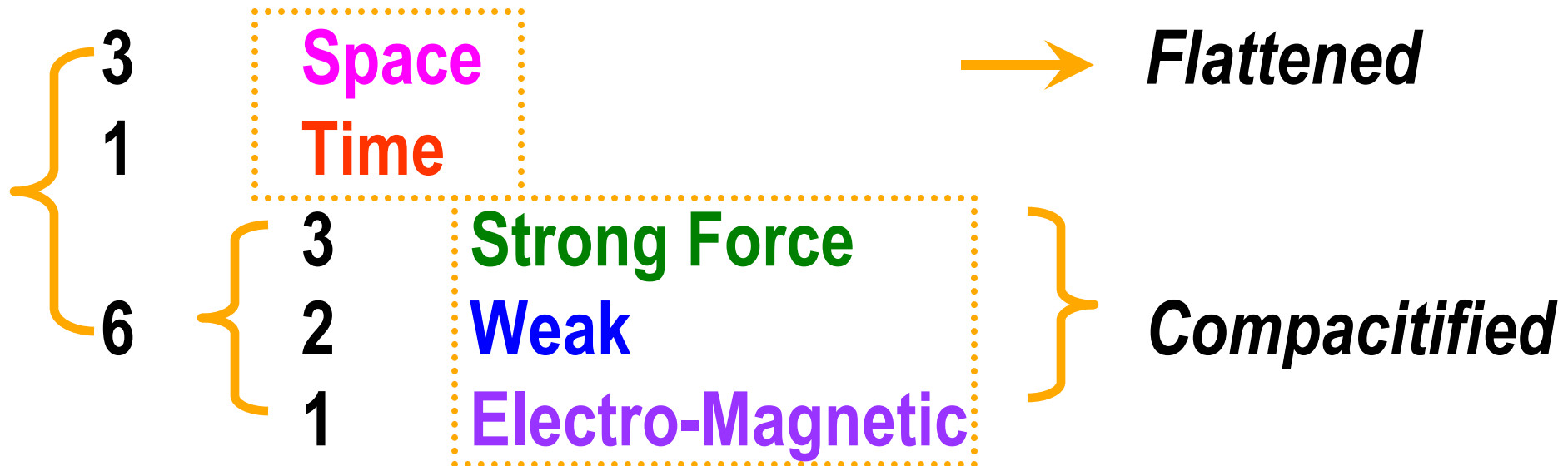

Spontaneous Symmetry Breakdown at a Dinner Table

Dinner Table

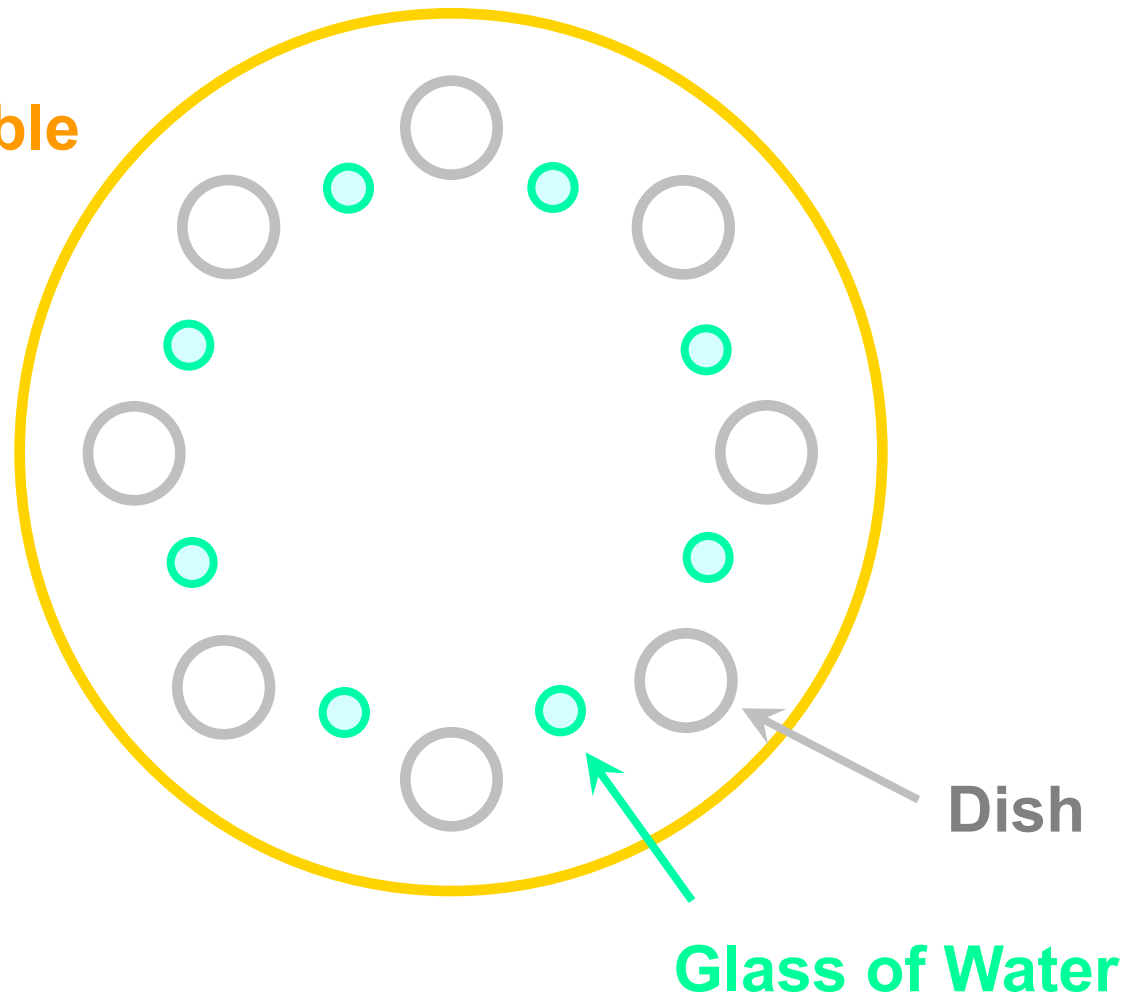

by Nambu Yoichiro

CERN and LHC in Geneva

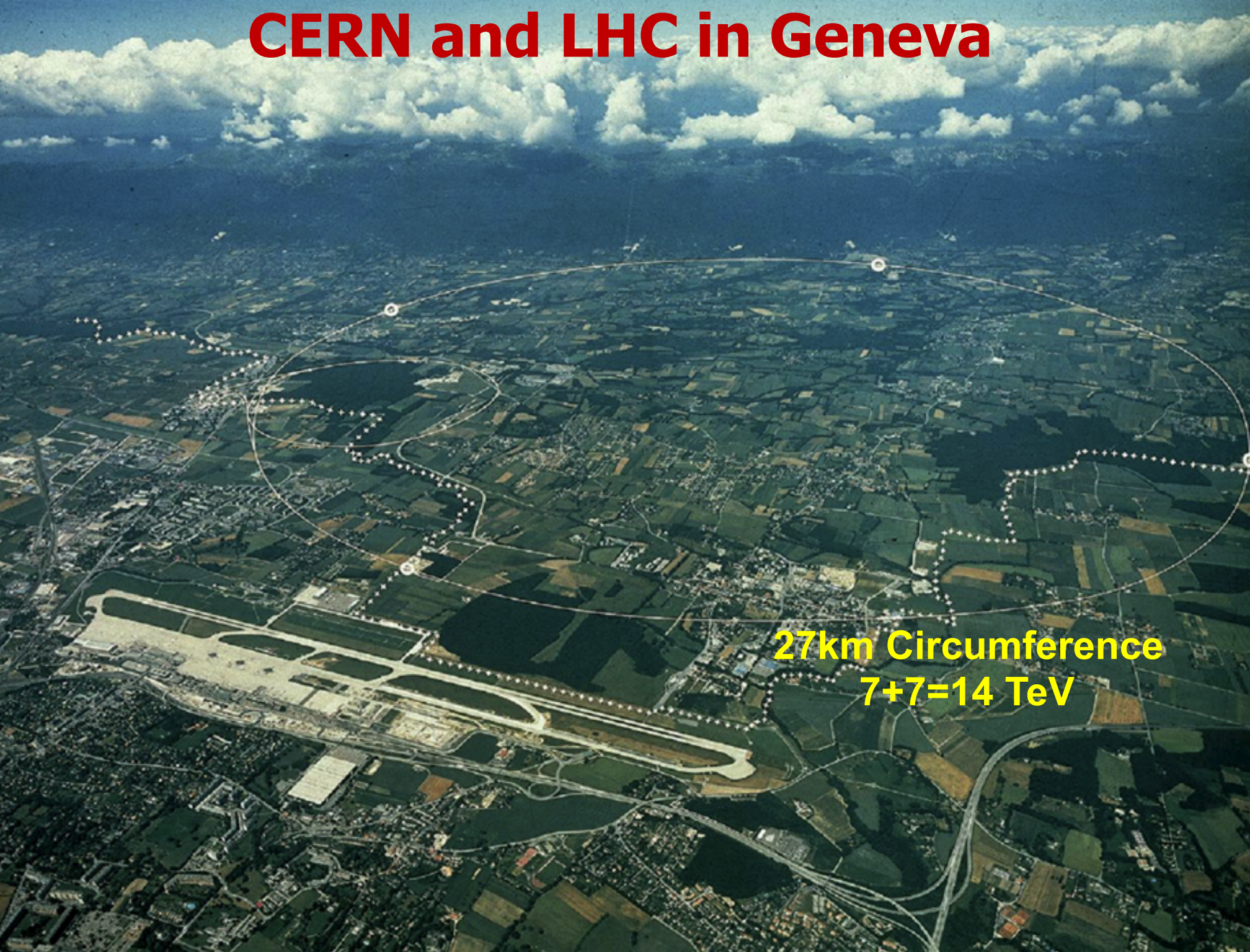

27km Circumference
7+7=14 TeV

LHC Tunnel with Magnets



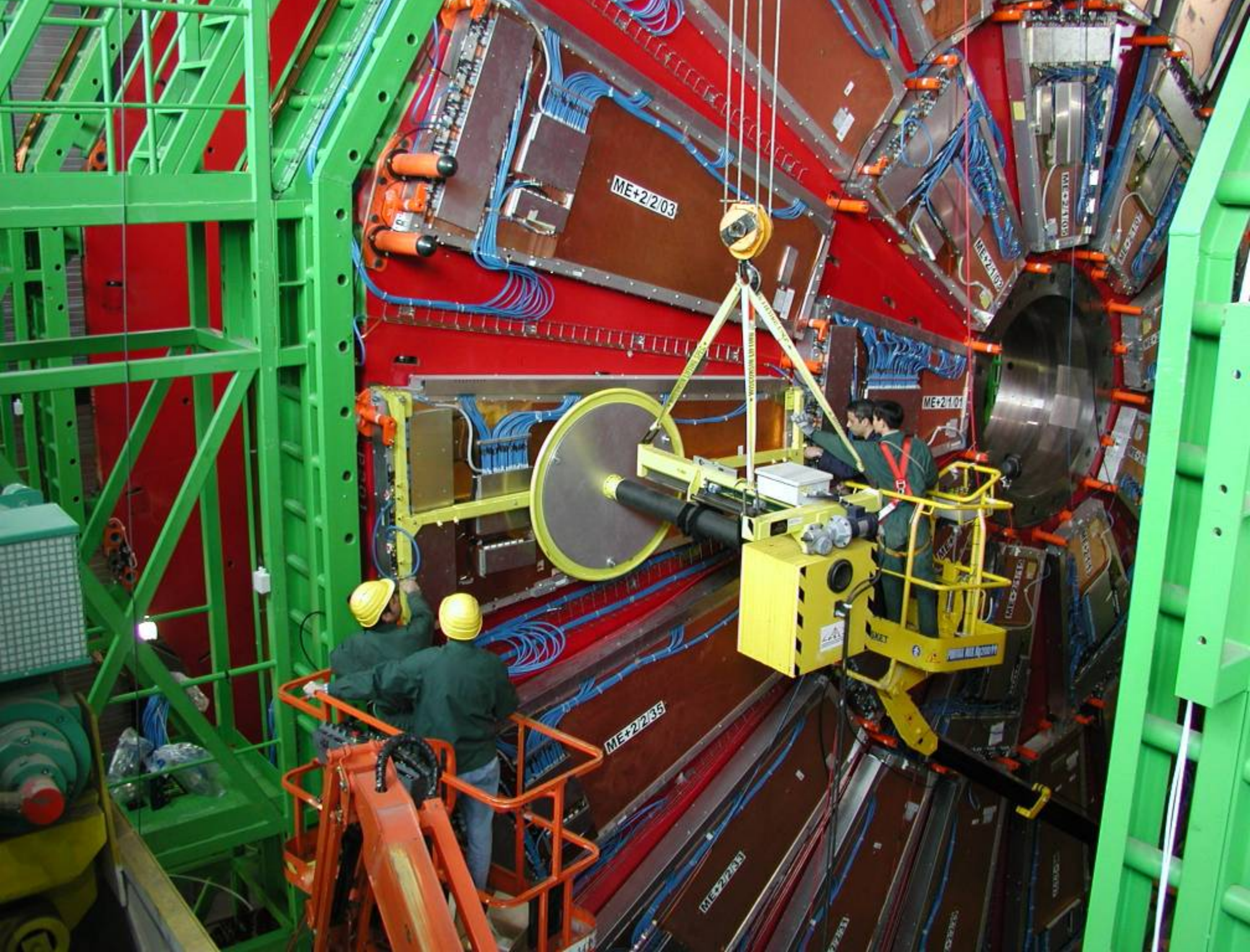

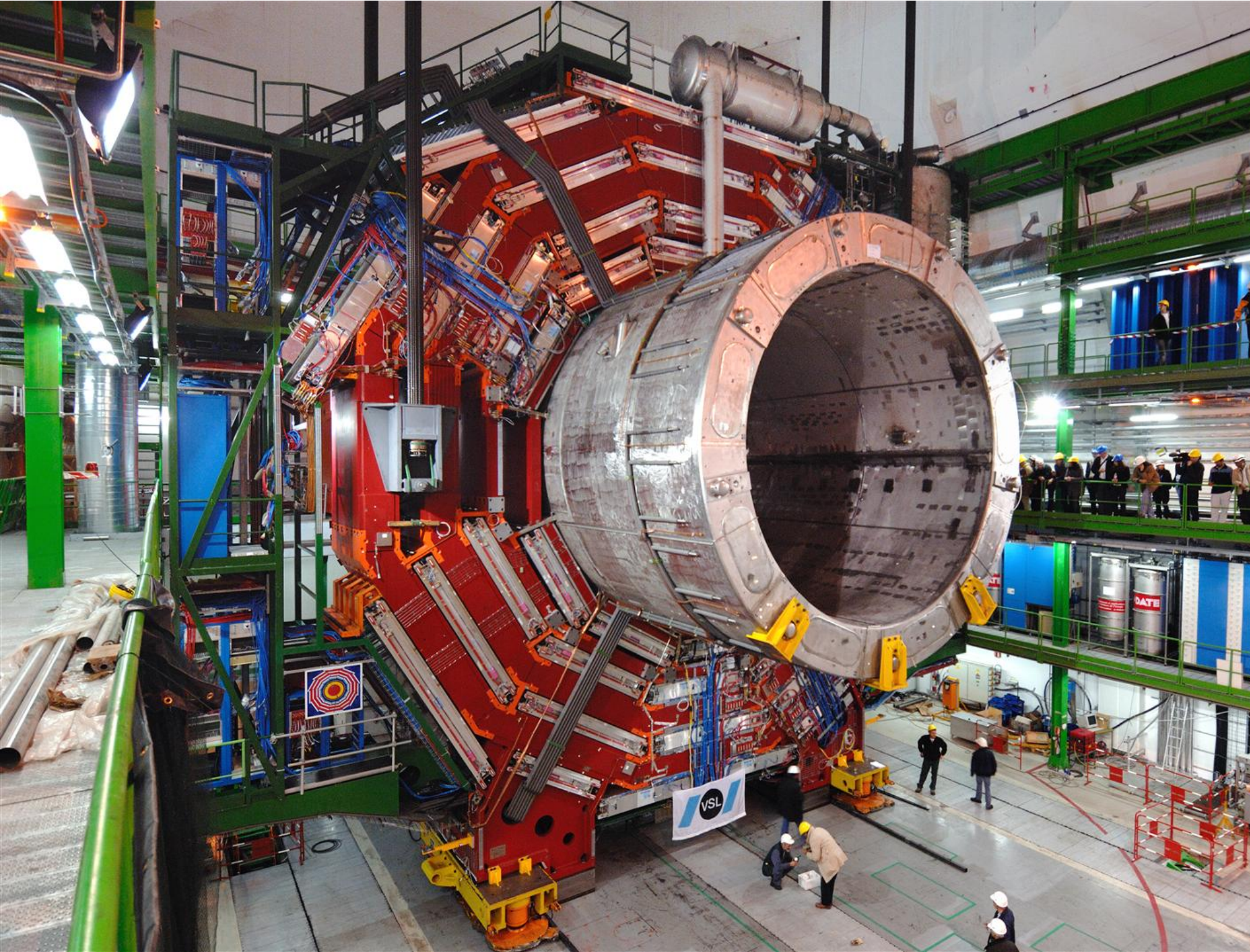

Sept 15, 2008

Newsweek

The Biggest Experiment Ever (And It's European)



PHOTOGRAPH BY MARTIAL TREZZINI—AP

SEPTEMBER 15, 2008

The new CERN collider in Geneva

Albania	Lek 600	Finland	€4.40	Israel	NIS 20.00	Netherlands	€4.40	Slovenia	€3.40
Austria	€4.40	France	€4.40	Italy	€4.40	Norway	Kr 41.00	Spain	€4.40
Belgium	€4.40	Germany	€4.40	Kazakhstan	\$4.40	Poland (incl tax)	PLN 12.30	Sweden	SKr 34.00
Bulgaria	BGL 4.50	Gibraltar	€2.90	Latvia	\$4.40	Portugal Cont	€4.40	Switzerland	SF 7.70
Croatia	KN 22.00	Greece	€4.40	Lithuania	\$4.40	Romania	Lei 11.00	Turkey	YTL 4.00
Cyprus	€2.58/€4.40	Hungary	Ft. 700.00	Luxembourg	€4.40	Russia	€4.40	Ukraine	€4.40
Czech Republic	CZK 115.00	Iceland	IKR 390.00	Malta	Lm 1.70/€3.98	Serbia	DIN 240	United Kingdom	£2.80
Denmark	Kr 38.00	Ireland (incl tax)	€4.40	Montenegro	DIN 240	Slovakia	SK 120.00/€3.98	U.S. Forces	\$3.25

newsweek.com



7/1/2010

23

CMS Detector

Data_taken 2009-Nov-07 19:12:36.880368 GMT

Run_no 120015

Event_no 8

Lumi_sec 1

Orbit 584946

Crossing 2603

<http://iguana.cern.ch/isy/>

L1 Triggers:

-
- L1_DoubleHfBitCountsRing1_P1N1
- L1_DoubleHfBitCountsRing2_P1N1
- L1_ETM20
- L1_ETM30
- L1_MinBias_HTT10
- L1_Mu3QE8_Jet6
- L1_SingleEG1
- L1_SingleEG10
- L1_SingleEG12
- L1_SingleEG15
- L1_SingleEG20
- L1_SingleEG25
- L1_SingleEG30
- L1_SingleEG35
- L1_SingleEG40
- L1_SingleEG45
- L1_SingleEG50
- L1_SingleEG55
- L1_SingleEG60
- L1_SingleEG65
- L1_SingleEG70
- L1_SingleEG75
- L1_SingleEG80
- L1_SingleEG85
- L1_SingleEG90
- L1_SingleEG95
- L1_SingleEG100
- L1_SingleEG105
- L1_SingleEG110
- L1_SingleEG115
- L1_SingleEG120
- L1_SingleEG125
- L1_SingleEG130
- L1_SingleEG135
- L1_SingleEG140
- L1_SingleEG145
- L1_SingleEG150
- L1_SingleEG155
- L1_SingleEG160
- L1_SingleEG165
- L1_SingleEG170
- L1_SingleEG175
- L1_SingleEG180
- L1_SingleEG185
- L1_SingleEG190
- L1_SingleEG195
- L1_SingleEG200
- L1_SingleEG205
- L1_SingleEG210
- L1_SingleEG215
- L1_SingleEG220
- L1_SingleEG225
- L1_SingleEG230
- L1_SingleEG235
- L1_SingleEG240
- L1_SingleEG245
- L1_SingleEG250
- L1_SingleEG255
- L1_SingleEG260
- L1_SingleEG265
- L1_SingleEG270
- L1_SingleEG275
- L1_SingleEG280
- L1_SingleEG285
- L1_SingleEG290
- L1_SingleEG295
- L1_SingleEG300
- L1_SingleEG305
- L1_SingleEG310
- L1_SingleEG315
- L1_SingleEG320
- L1_SingleEG325
- L1_SingleEG330
- L1_SingleEG335
- L1_SingleEG340
- L1_SingleEG345
- L1_SingleEG350
- L1_SingleEG355
- L1_SingleEG360
- L1_SingleEG365
- L1_SingleEG370
- L1_SingleEG375
- L1_SingleEG380
- L1_SingleEG385
- L1_SingleEG390
- L1_SingleEG395
- L1_SingleEG400
- L1_SingleEG405
- L1_SingleEG410
- L1_SingleEG415
- L1_SingleEG420
- L1_SingleEG425
- L1_SingleEG430
- L1_SingleEG435
- L1_SingleEG440
- L1_SingleEG445
- L1_SingleEG450
- L1_SingleEG455
- L1_SingleEG460
- L1_SingleEG465
- L1_SingleEG470
- L1_SingleEG475
- L1_SingleEG480
- L1_SingleEG485
- L1_SingleEG490
- L1_SingleEG495
- L1_SingleEG500
- L1_SingleEG505
- L1_SingleEG510
- L1_SingleEG515
- L1_SingleEG520
- L1_SingleEG525
- L1_SingleEG530
- L1_SingleEG535
- L1_SingleEG540
- L1_SingleEG545
- L1_SingleEG550
- L1_SingleEG555
- L1_SingleEG560
- L1_SingleEG565
- L1_SingleEG570
- L1_SingleEG575
- L1_SingleEG580
- L1_SingleEG585
- L1_SingleEG590
- L1_SingleEG595
- L1_SingleEG600
- L1_SingleEG605
- L1_SingleEG610
- L1_SingleEG615
- L1_SingleEG620
- L1_SingleEG625
- L1_SingleEG630
- L1_SingleEG635
- L1_SingleEG640
- L1_SingleEG645
- L1_SingleEG650
- L1_SingleEG655
- L1_SingleEG660
- L1_SingleEG665
- L1_SingleEG670
- L1_SingleEG675
- L1_SingleEG680
- L1_SingleEG685
- L1_SingleEG690
- L1_SingleEG695
- L1_SingleEG700
- L1_SingleEG705
- L1_SingleEG710
- L1_SingleEG715
- L1_SingleEG720
- L1_SingleEG725
- L1_SingleEG730
- L1_SingleEG735
- L1_SingleEG740
- L1_SingleEG745
- L1_SingleEG750
- L1_SingleEG755
- L1_SingleEG760
- L1_SingleEG765
- L1_SingleEG770
- L1_SingleEG775
- L1_SingleEG780
- L1_SingleEG785
- L1_SingleEG790
- L1_SingleEG795
- L1_SingleEG800
- L1_SingleEG805
- L1_SingleEG810
- L1_SingleEG815
- L1_SingleEG820
- L1_SingleEG825
- L1_SingleEG830
- L1_SingleEG835
- L1_SingleEG840
- L1_SingleEG845
- L1_SingleEG850
- L1_SingleEG855
- L1_SingleEG860
- L1_SingleEG865
- L1_SingleEG870
- L1_SingleEG875
- L1_SingleEG880
- L1_SingleEG885
- L1_SingleEG890
- L1_SingleEG895
- L1_SingleEG900
- L1_SingleEG905
- L1_SingleEG910
- L1_SingleEG915
- L1_SingleEG920
- L1_SingleEG925
- L1_SingleEG930
- L1_SingleEG935
- L1_SingleEG940
- L1_SingleEG945
- L1_SingleEG950
- L1_SingleEG955
- L1_SingleEG960
- L1_SingleEG965
- L1_SingleEG970
- L1_SingleEG975
- L1_SingleEG980
- L1_SingleEG985
- L1_SingleEG990
- L1_SingleEG995

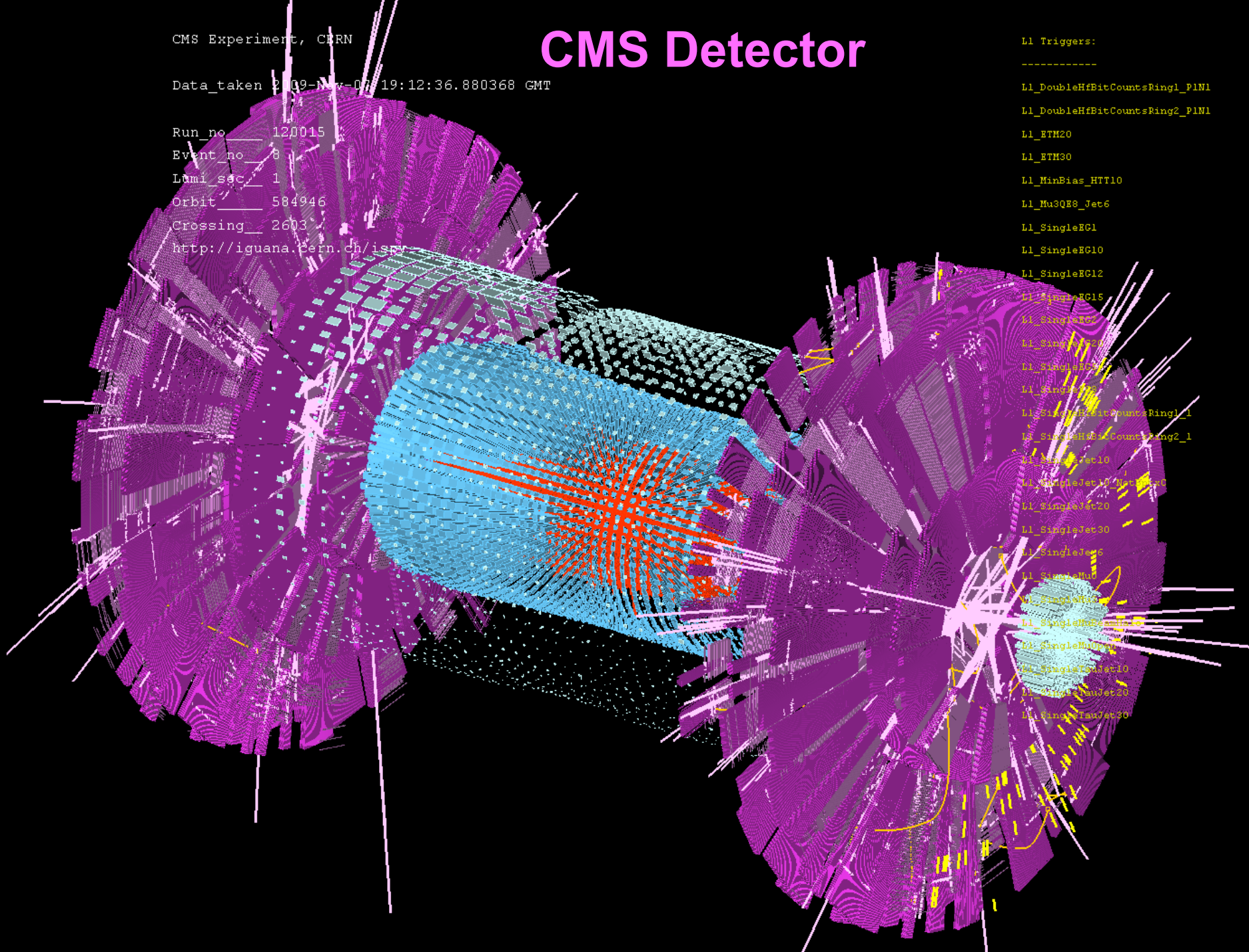

First Event at LHC – Recreation of the Big Bang! (Nov 7, 2009)

The Four Largest Mysteries in Nature

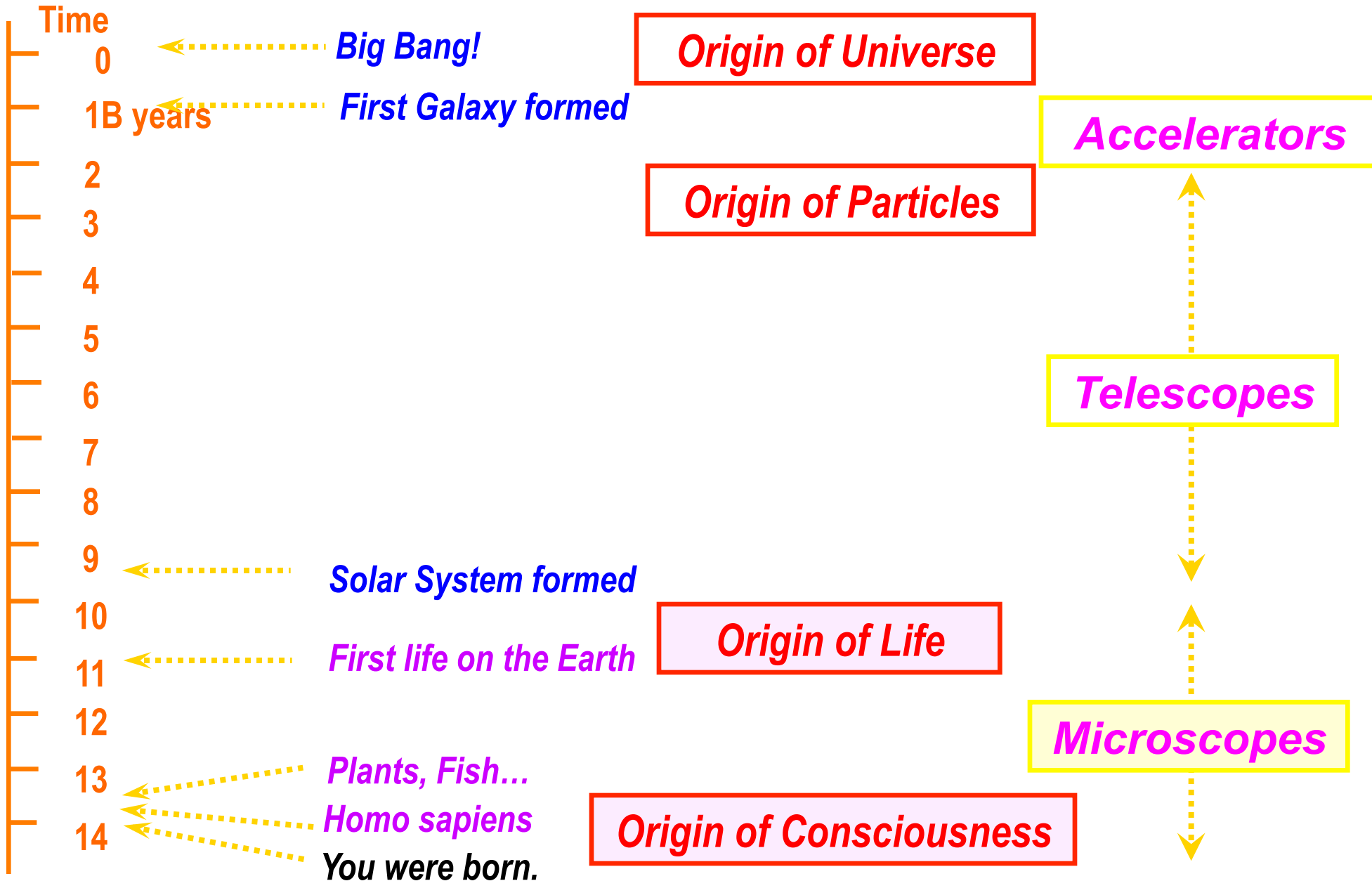

How to observe the Life and Consciousness ?

- We must look for “**Live Life**”
- Exactly the same way as we look for the “**Origin of Universe**”
Telescope ↔ **Microscope**
- Take advantages of the state of art “**Photon Detectors**” in particle physics.

Origin of Life

Organic Polymers (4.5B → 4B years)

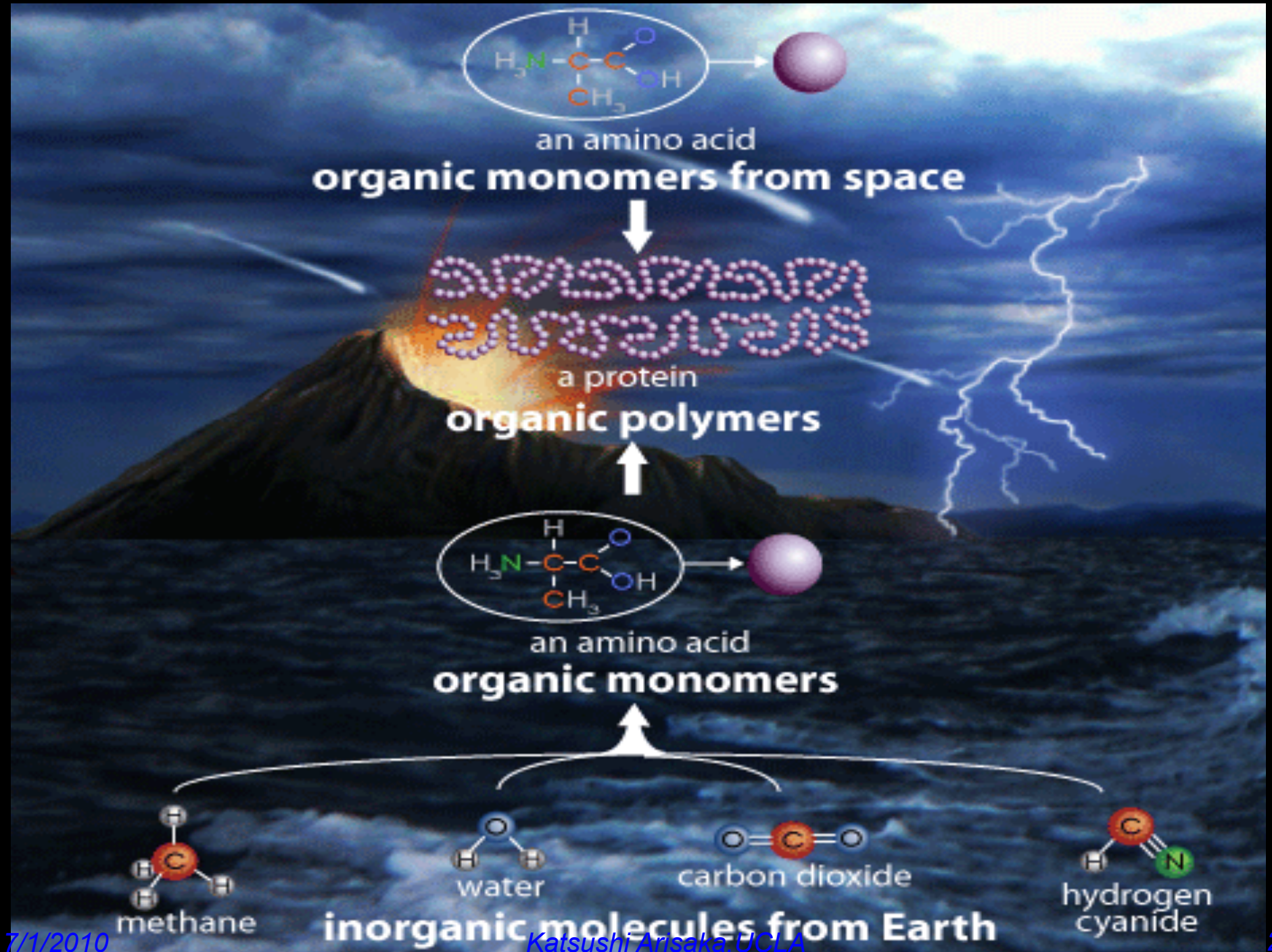

RNA World (4B → 3.5B years ago)

1. Organic precursor molecules appear.

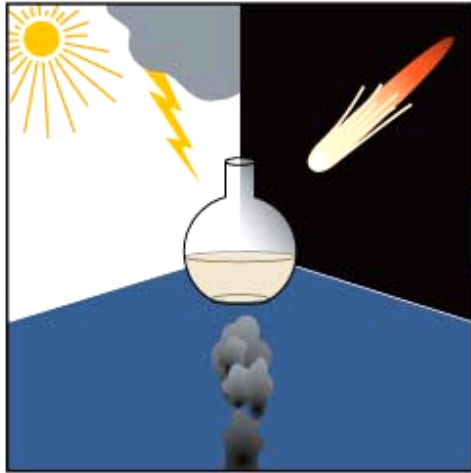

2. RNA molecules become self-replicating.

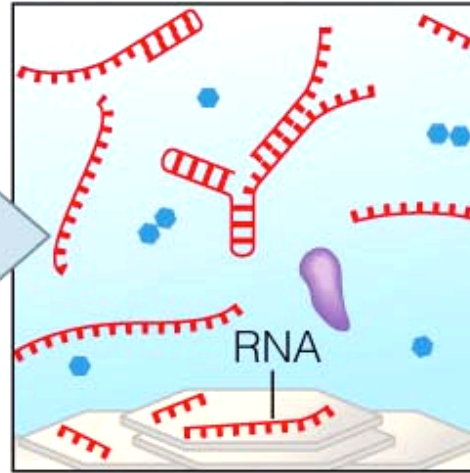

3. Membrane-enclosed pre-cells arise.

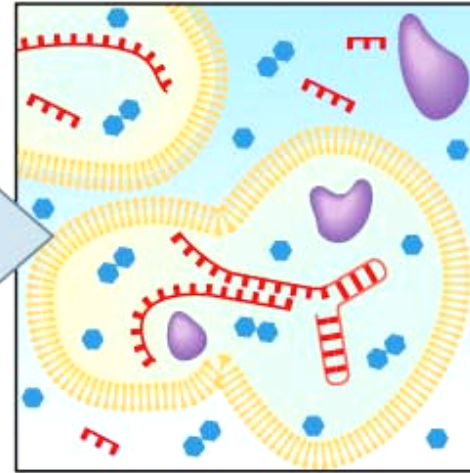

Copyright © 2007 Pearson Education, Inc., publishing as Pearson

4. True cells with RNA genome appear.

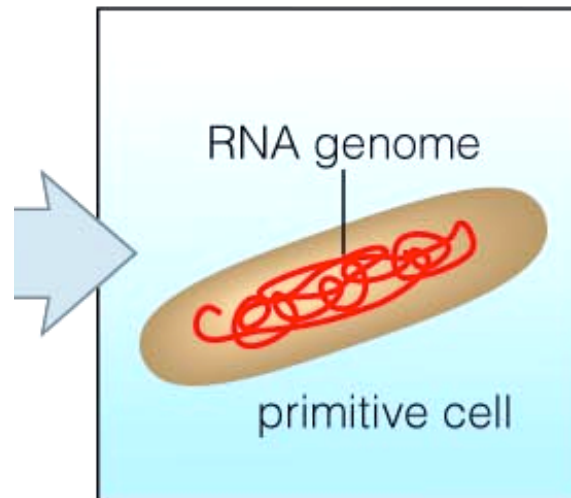

5. Modern cells with DNA genome evolve.

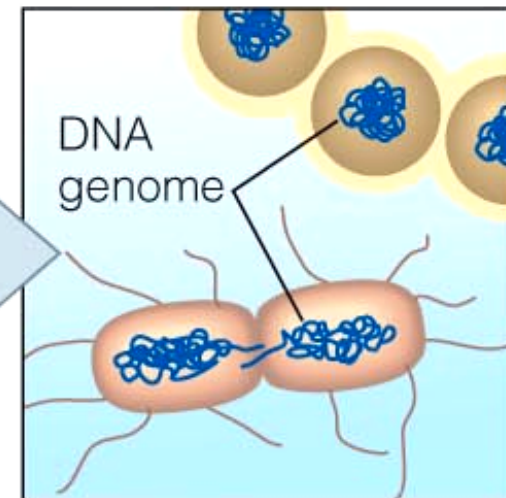

Eukaryote (~2B years ago)

Symmetry breaking

Cell made by proteins



Gene made by DNA

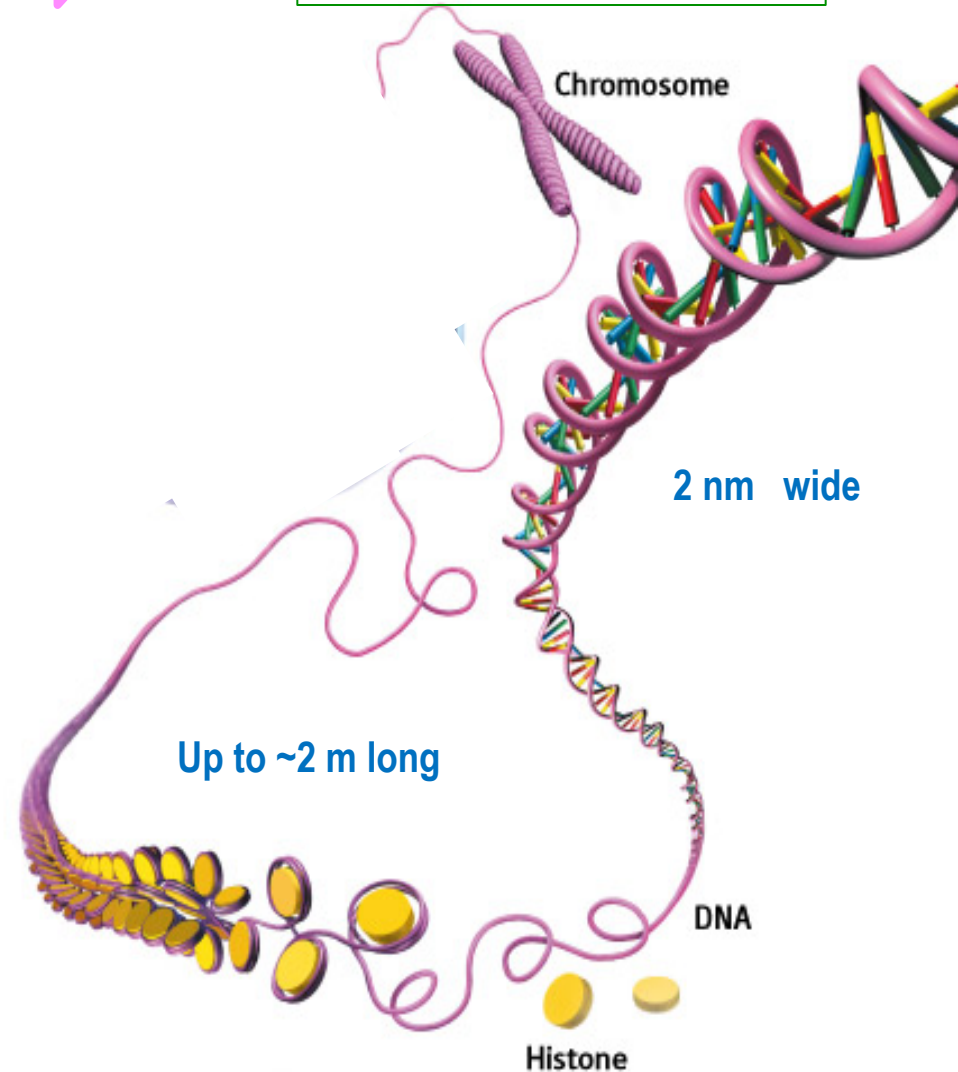
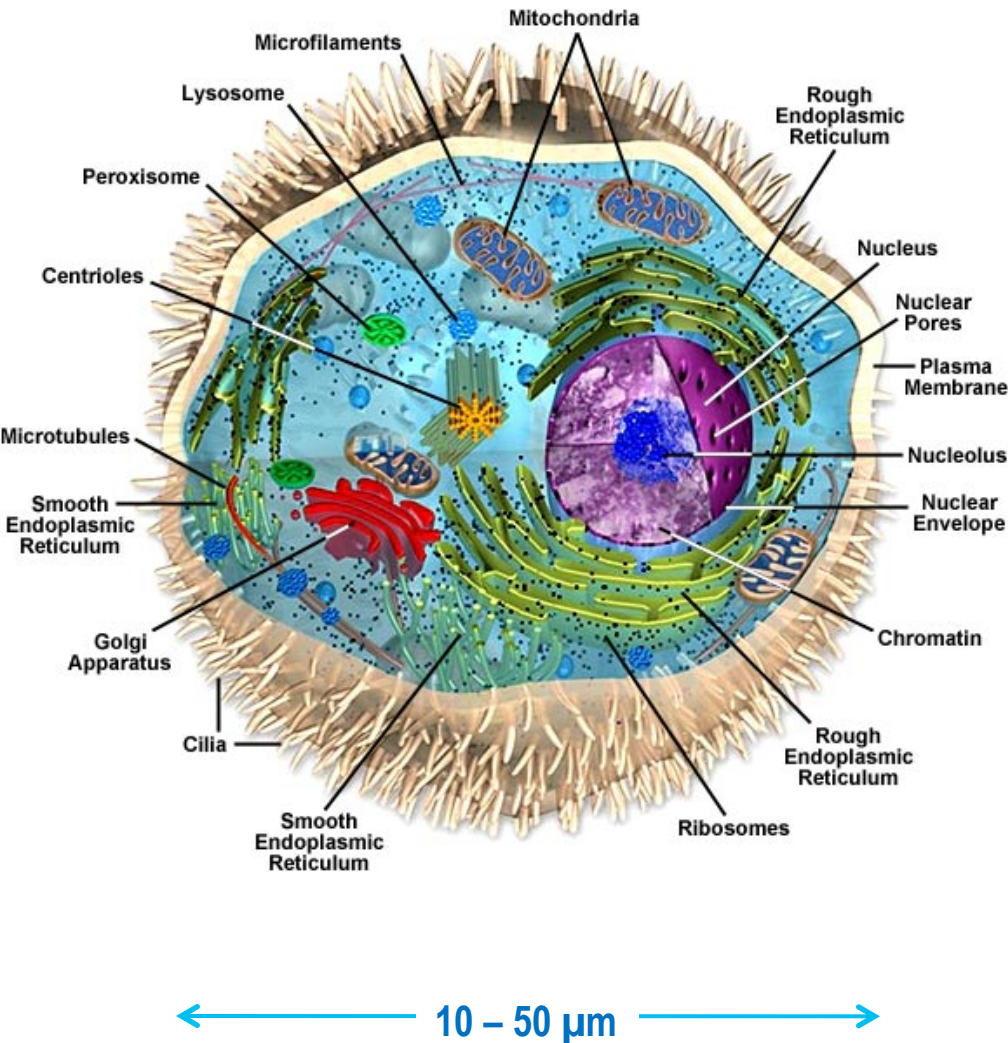

What is Life?

➤ Emergent Property

- Strongly-interacting, complex system
- $\sim 10^4$ of different proteins in one cell
- $\sim 10^{14}$ cells in one life

➤ Continuous, countless “symmetry breaking” towards coherent states

- Origin of life
- Evolution of life
- Growth from a single cell to a multi-cell body
- Learning and memory

Emission of Quantum Dot

Shimon Weiss (Chemistry)

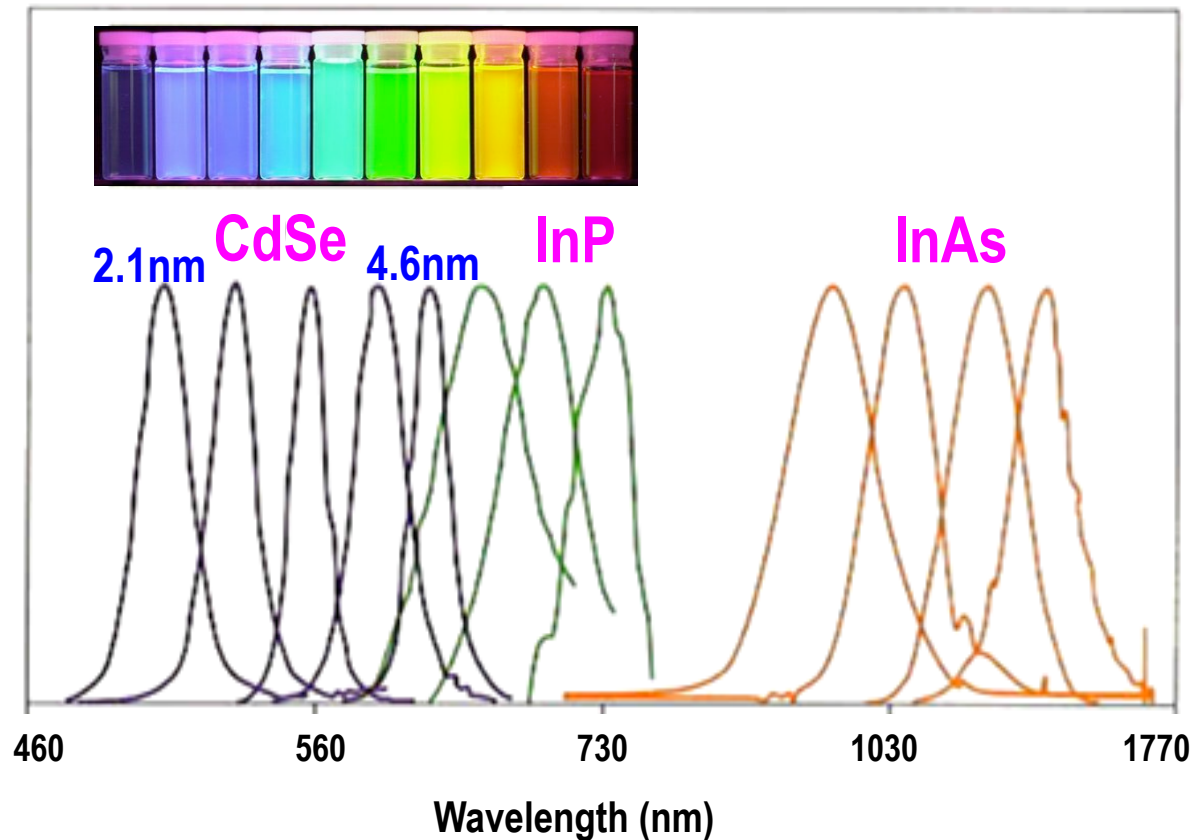
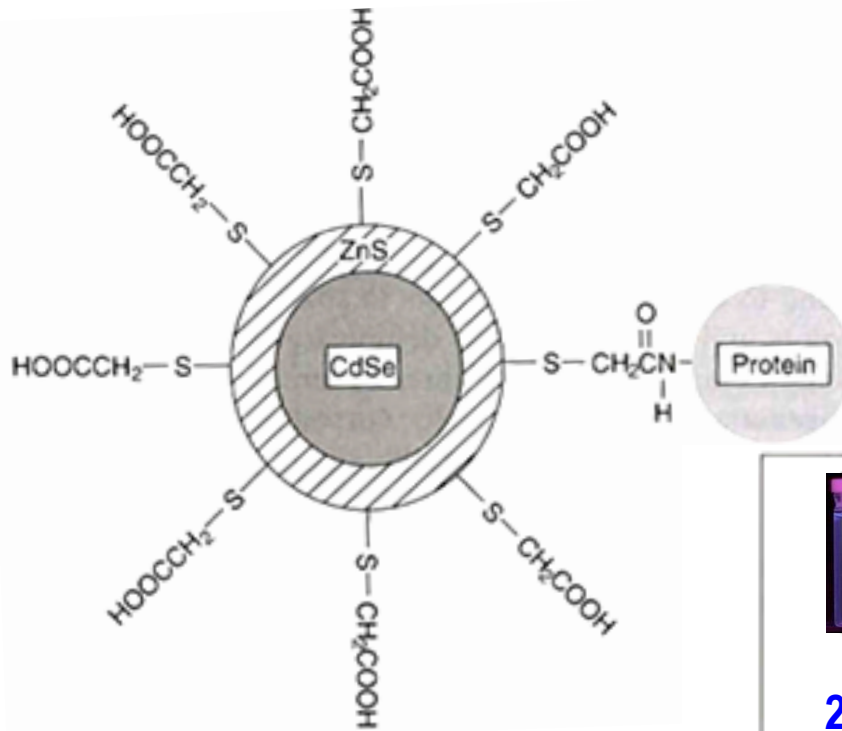

Protein Folding by single pair Förster Resonant Energy Transfer (spFRET)

Shimon Weiss (Chemistry)

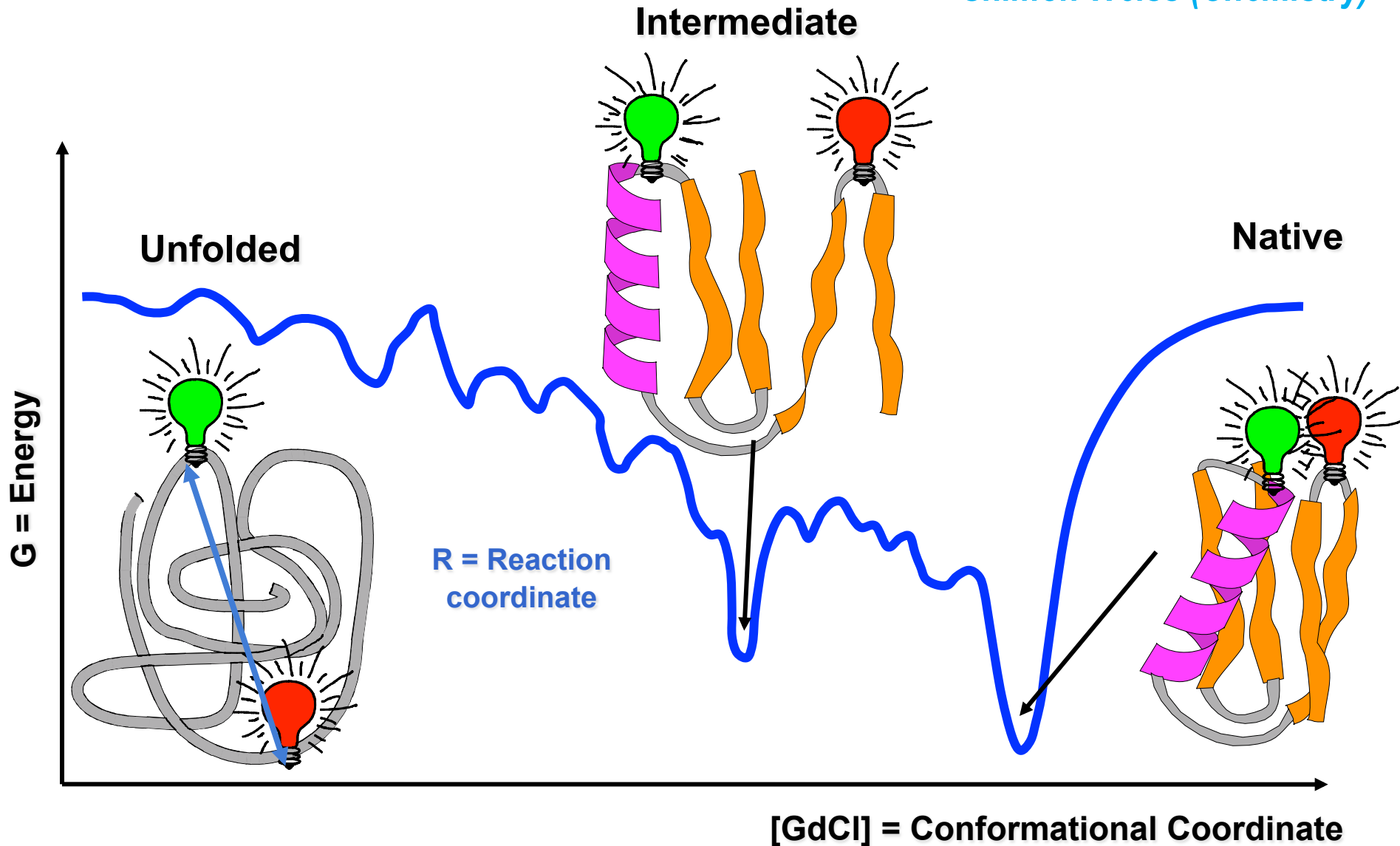

Förster Resonant Energy Transfer (FRET)

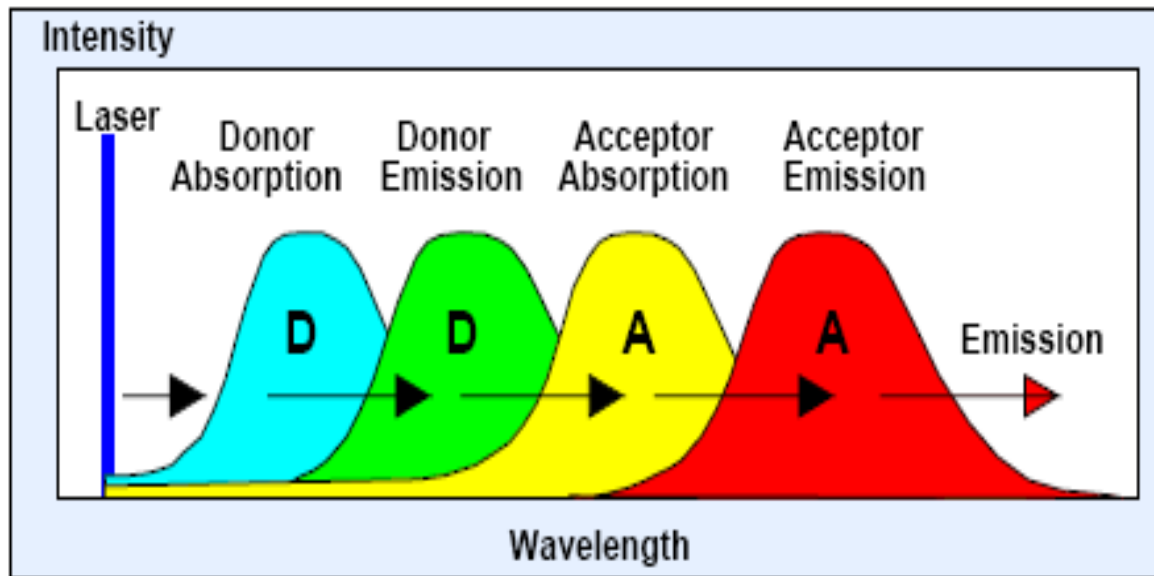

nm \rightarrow *nsec*

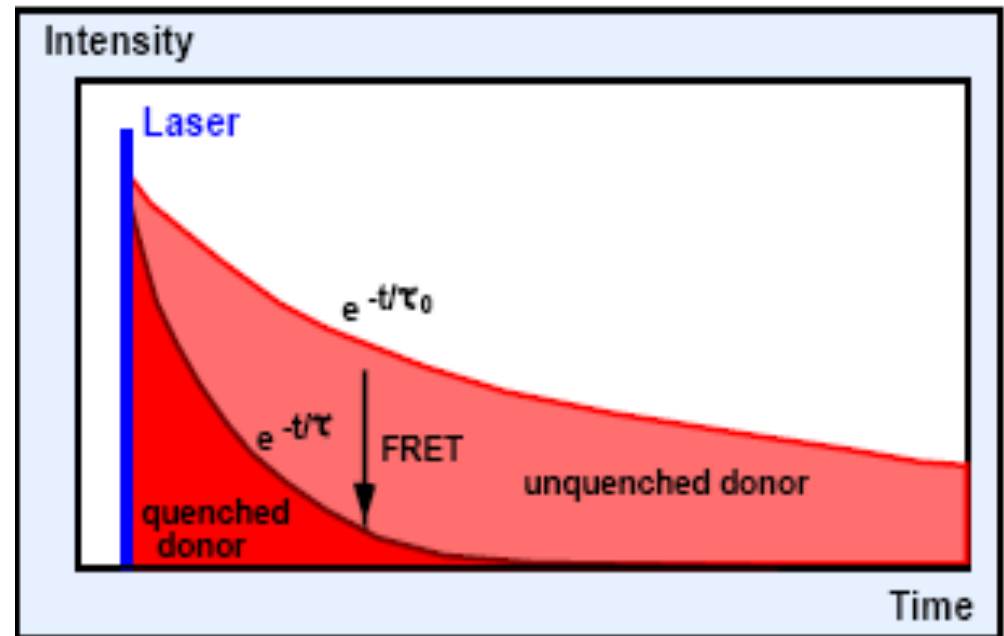
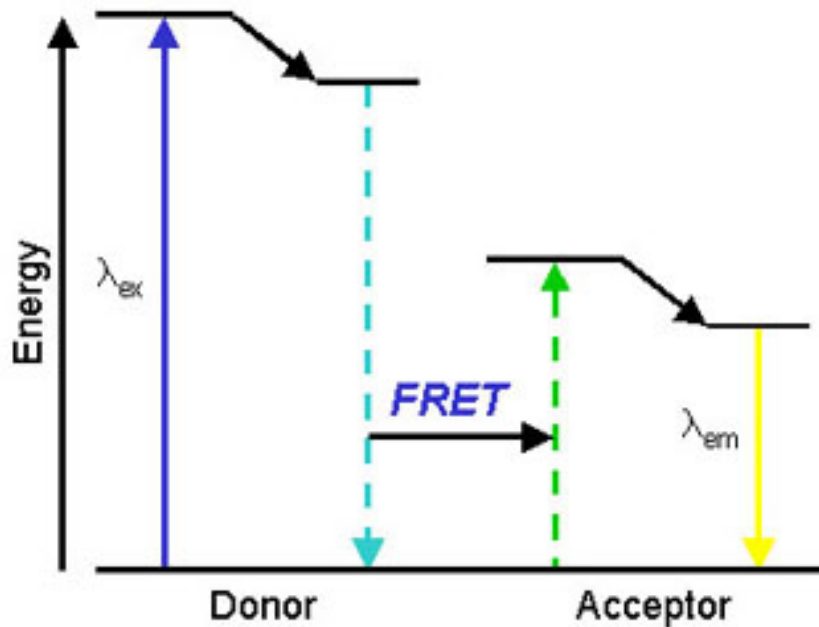

Hamamatsu Hybrid APD

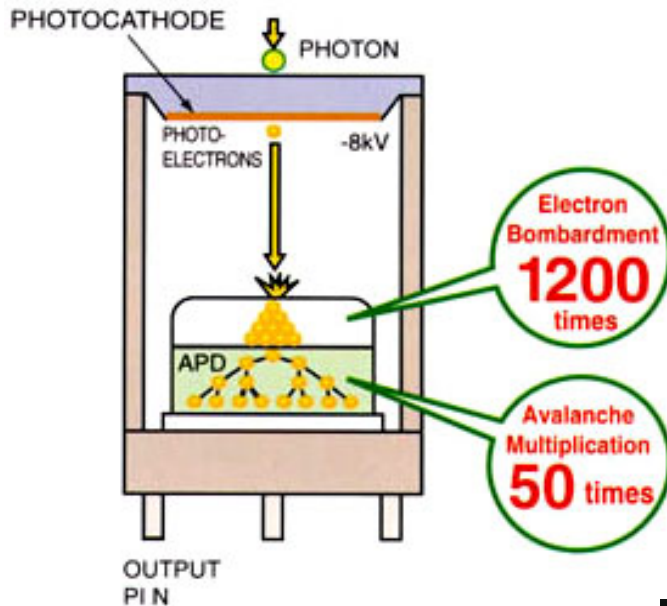

Single Channel
HAPD

64 Channel HAPD
+ Readout

Motohiro Suyama
(Hamamatsu)
Xavier Michalet
Shimon Weiss
(Chemistry)

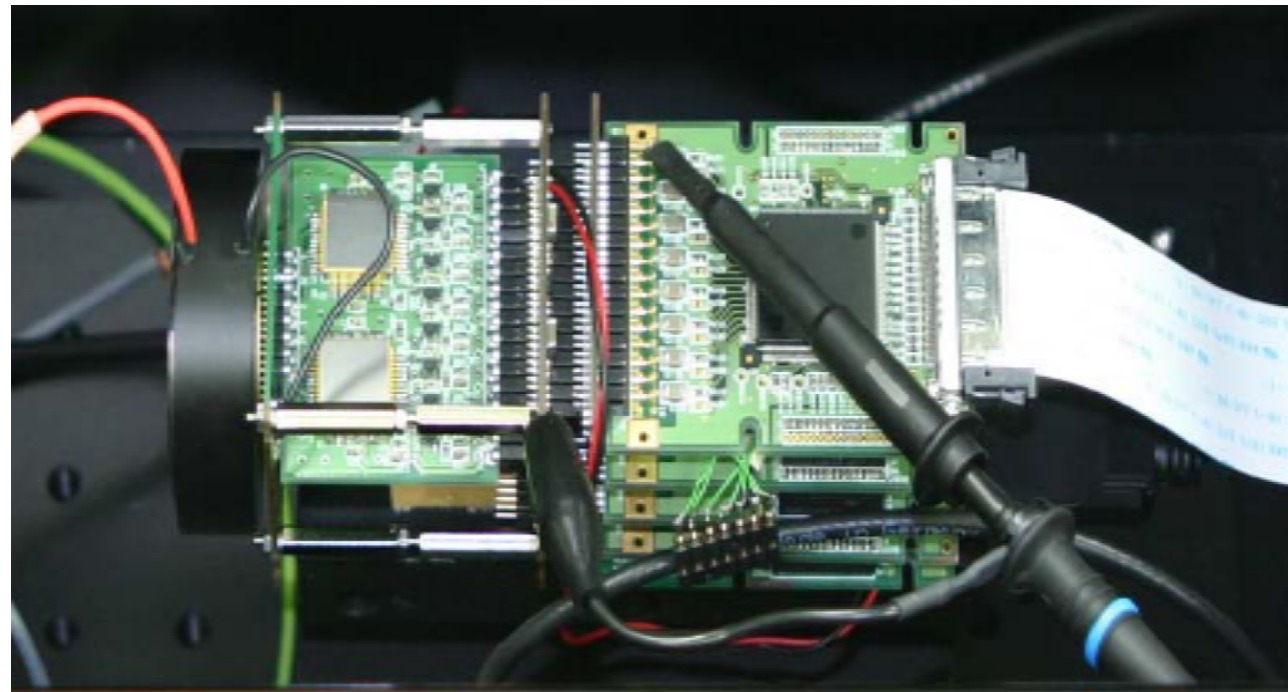

Quantum Efficiency of UBA, GaAsP and GaAs

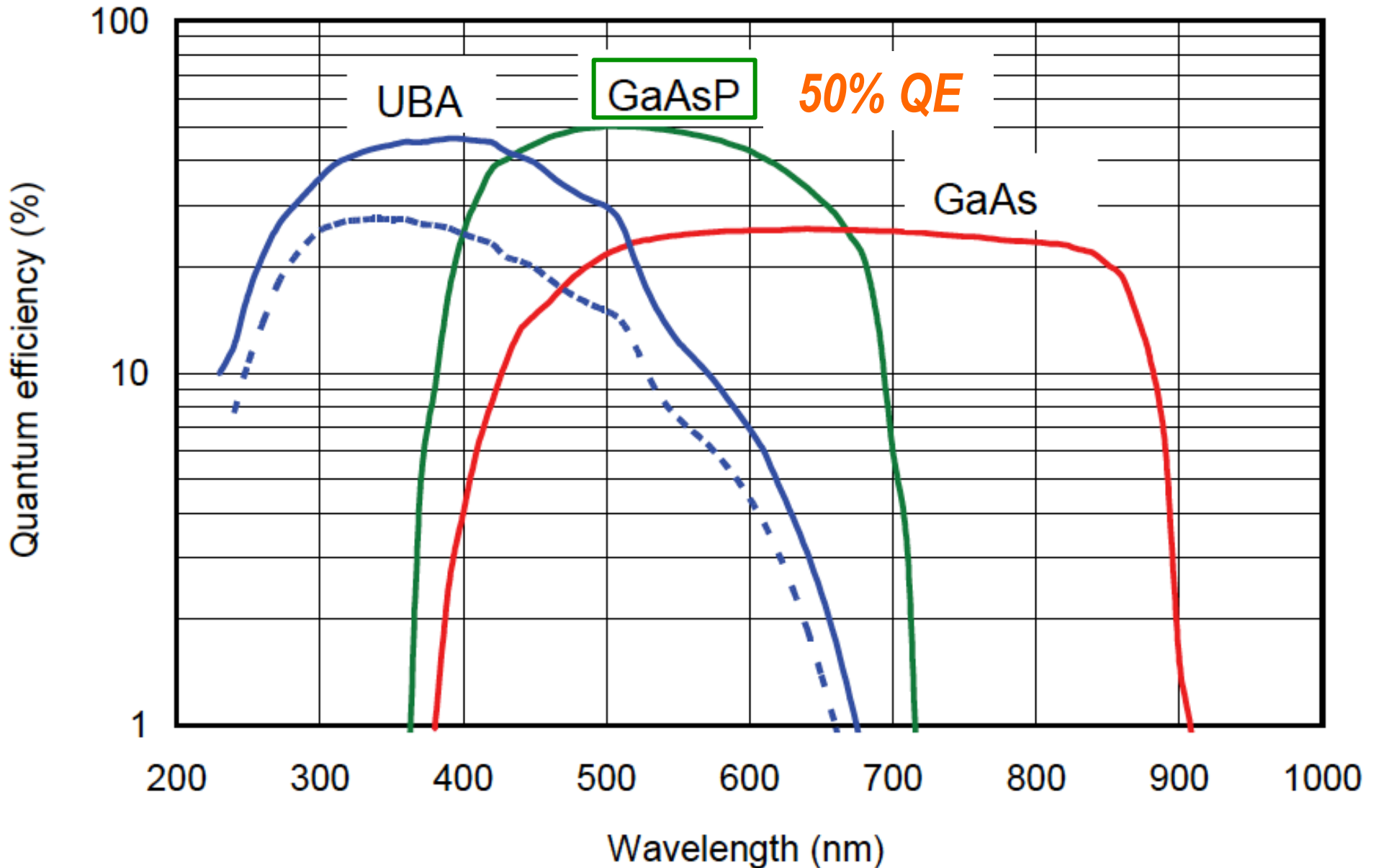

1, 2, 3 ... Photo-electron Distribution

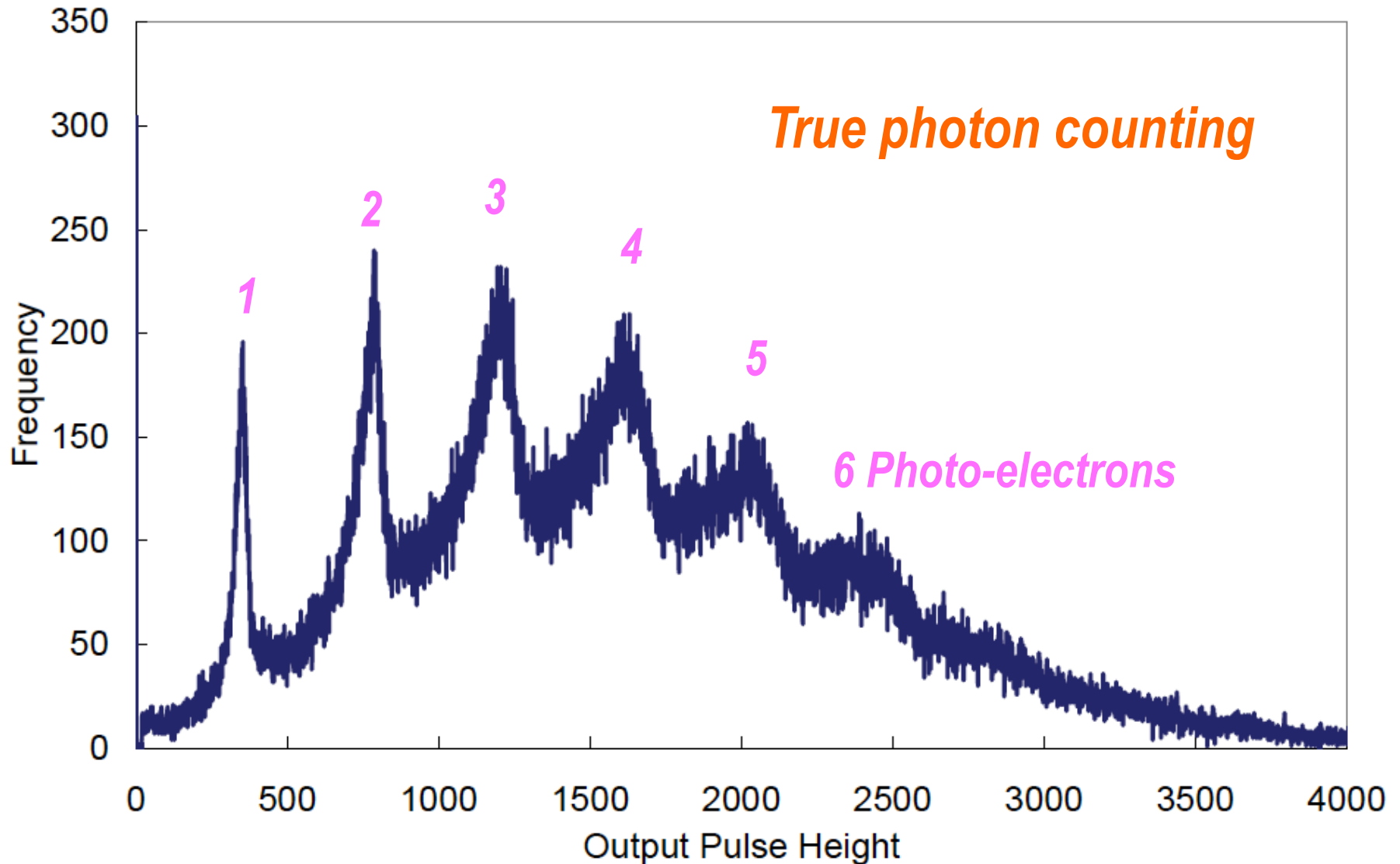

Decay Time Measurement by HAPD

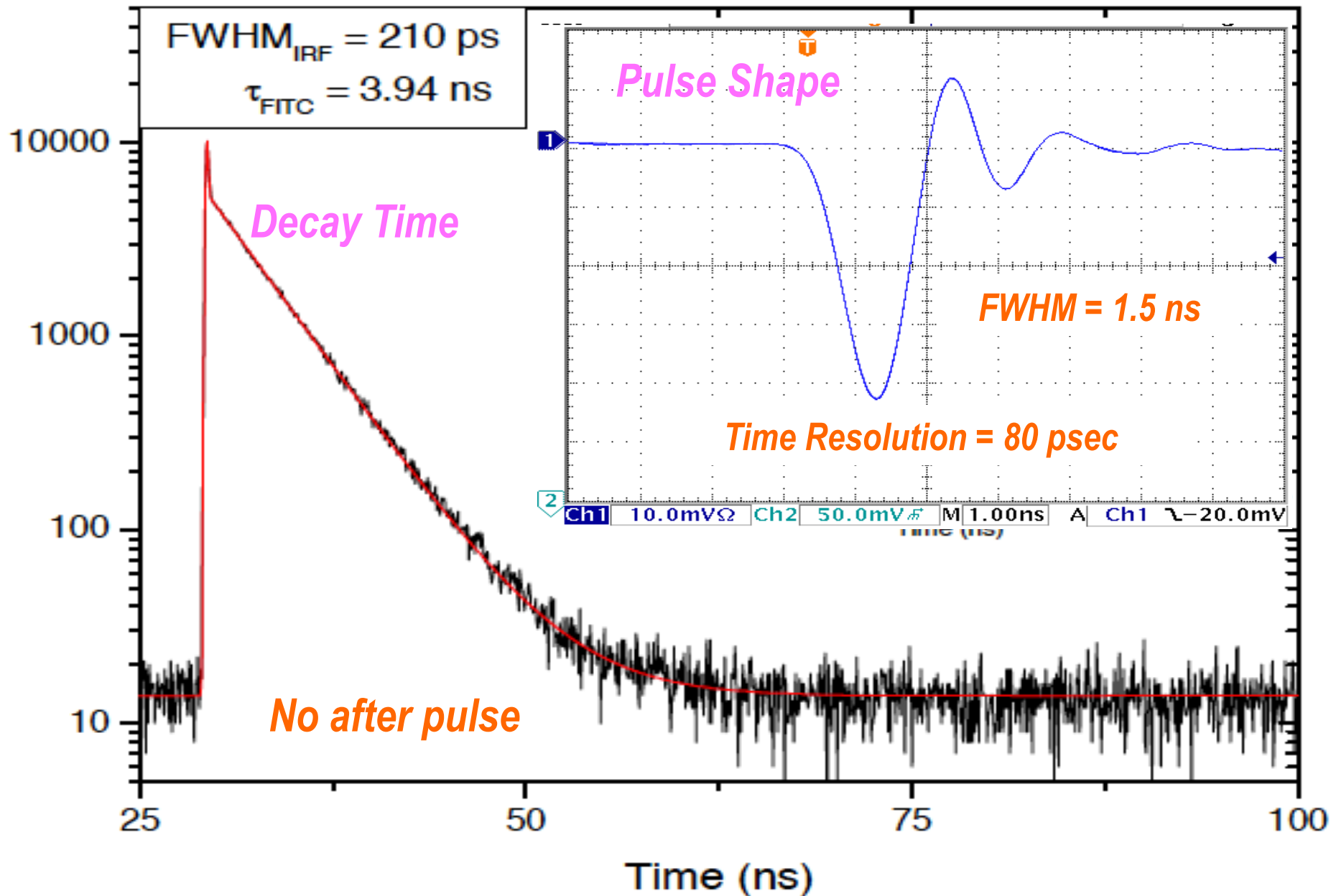

How to speed up microscopes

- All the existing microscopes are limited by the narrow bandwidth of readout.
 - Just one channel of FADC (Flash Analog to Digital Converter) running at 10 – 50 MHz
 - So-called Video Rate (30 frame/sec)
- The first step is to adopt multiple channels of FADC for massive parallel processing.
 - Like high energy experiments (such as LHC)
- In addition, we need Single Photon Sensitivity with high Quantum Efficiency.

Principle of High-speed Bio Imaging

Wide Field

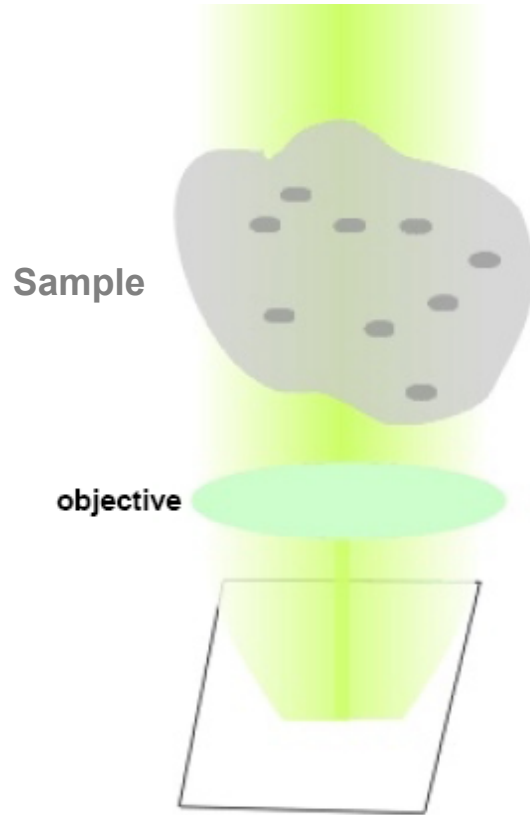

CCD + FADC (10 – 50 MHz)



CMOS [FADC (50 MHz) * 100]

Confocal

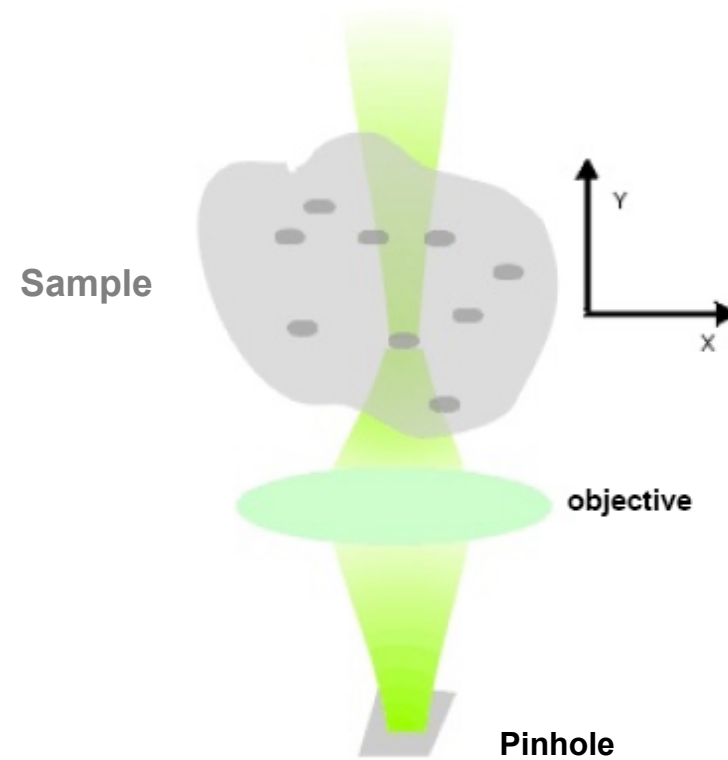

PMT + FADC (10 – 50 MHz)



[HAPD + FADC (1 GHz)] * 64

Block Diagram of Multi-beam Confocal Microscope

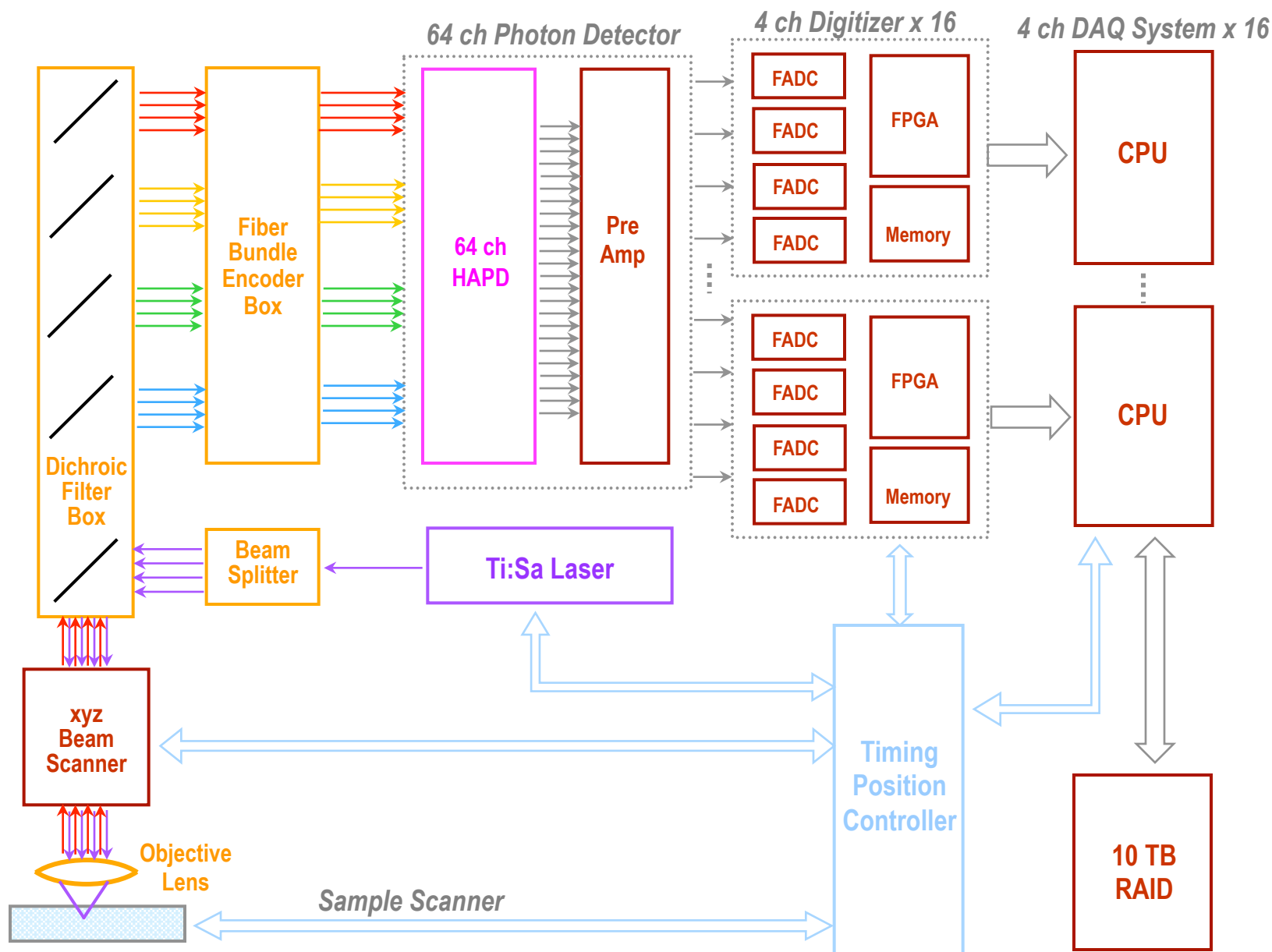

Micron 1.3M-Pixel CMOS Sensor

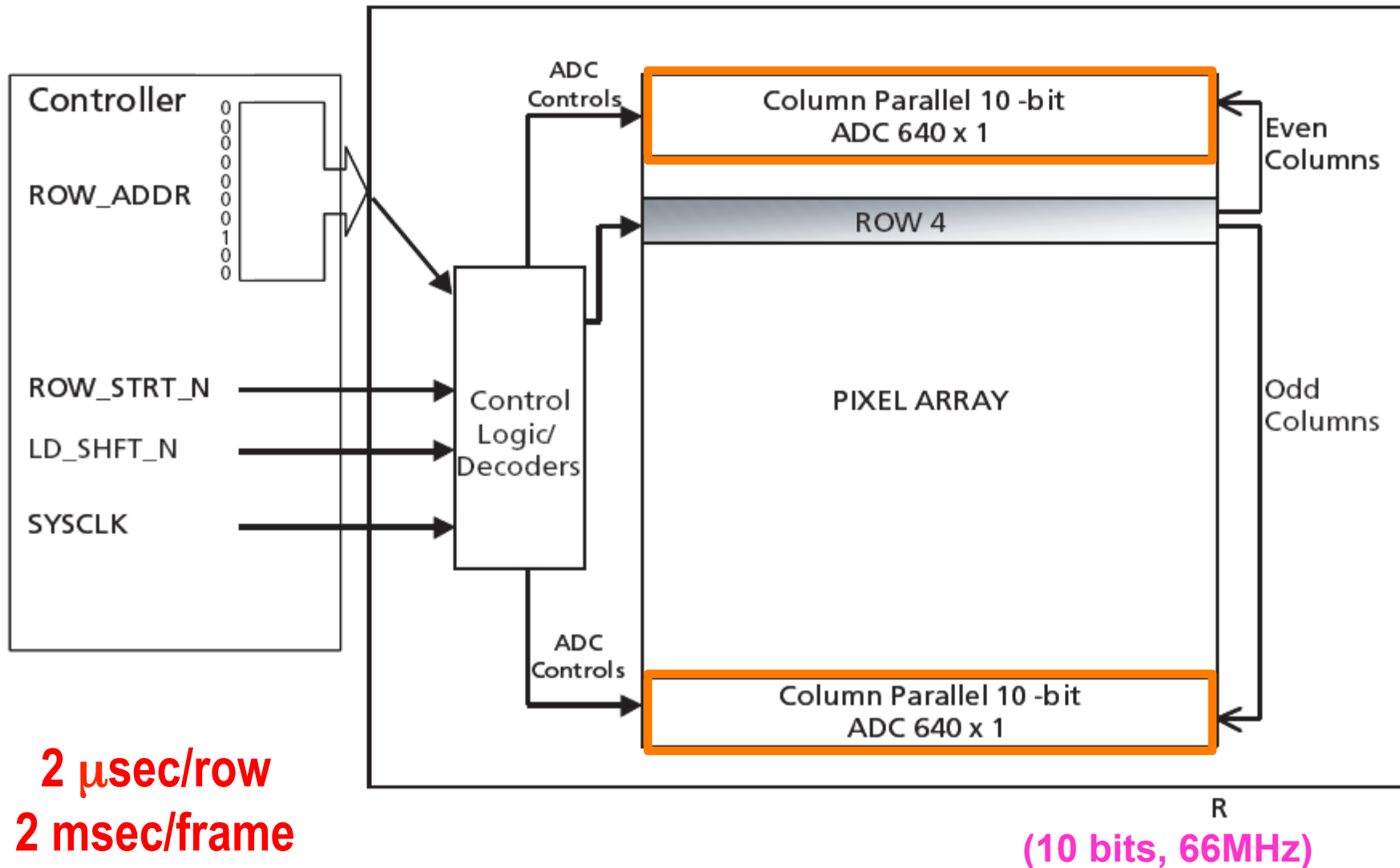

Photron SA-5 CMOS Camera



FRAME RATE (fps)	MAXIMUM RESOLUTION	
	Horizontal	Vertical
1,000	1,024	1,024
2,000	1,024	1,024
4,000	1,024	1,024
5,000	1,024	1,024
7,000	1,024	1,024
7,500	1,024	1,000
9,300	1,024	800
10,000	1,024	744
15,000	960	528
20,000	832	448
30,000	768	320
50,000	512	272
75,000	320	264
100,000	320	192
150,000	256	144
300,000	256	64
420,000	128	64
525,000	128	48
775,000	128	24
930,000	128	16
1,000,000	64	16

Gold nano particle (40nm) attached to Transferrin Receptor (TfR) on Cancer Cell

Manuel Penichet (Oncology), John Miao (Physics)

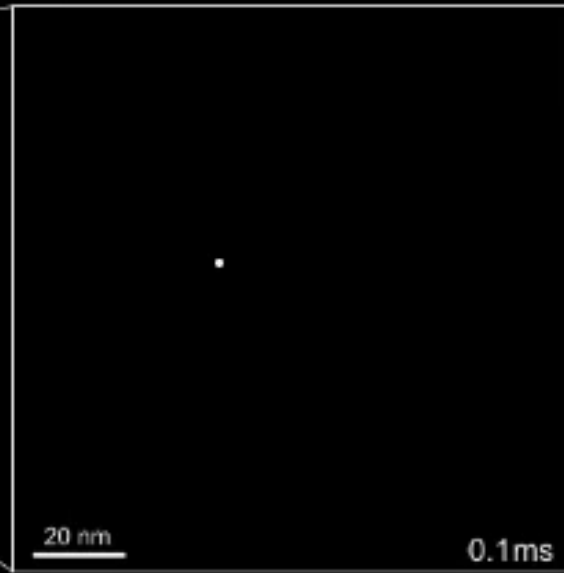
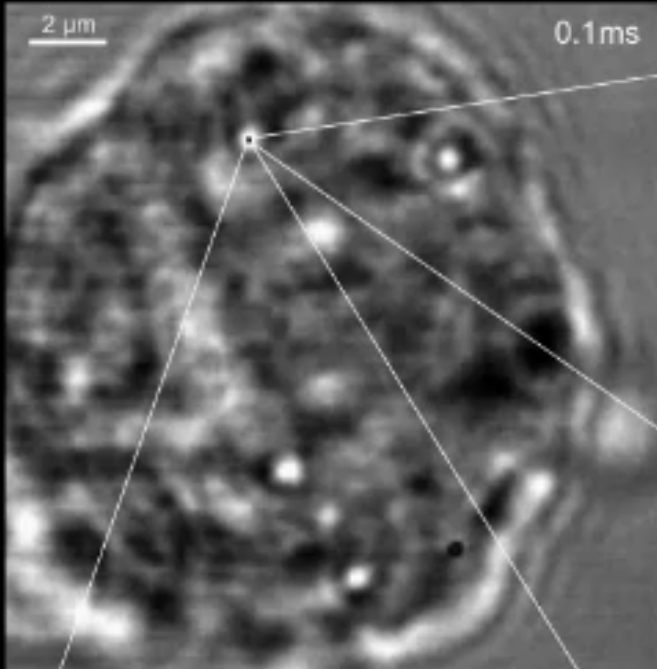

10,000 frame/sec

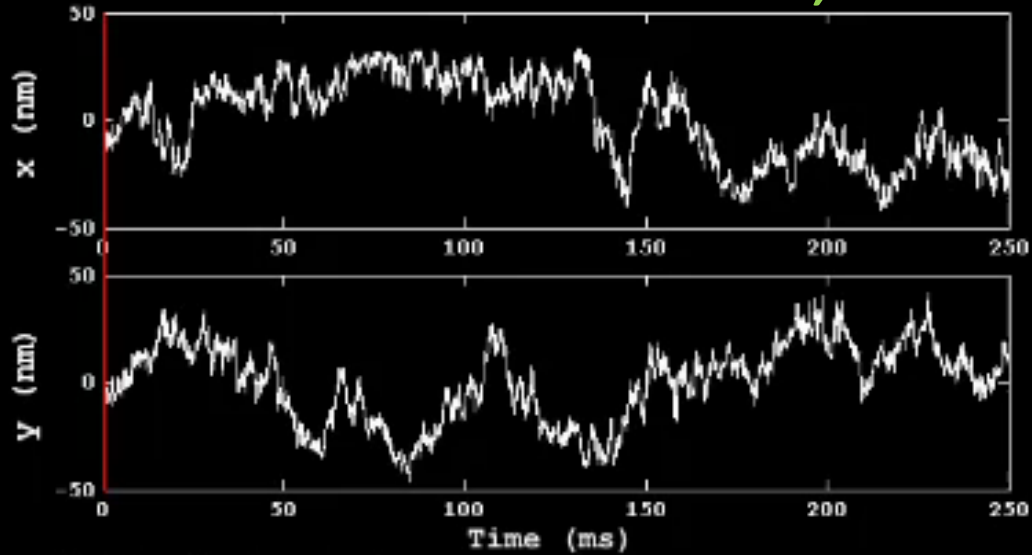
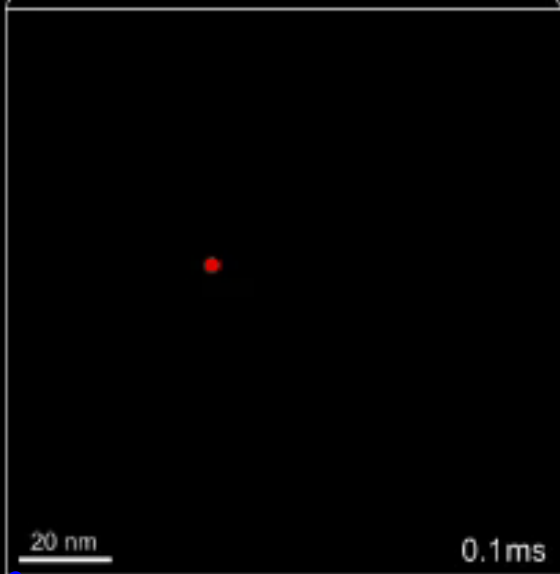

UCLA Fast Bio-Imaging Group

L. Fredrickson, A. Rodriguez, C. A. Cheng, K. Jewhurst, J. Miao, K. Arisaka

Mean Squire Displacement $\langle r^2 \rangle$ of TfR on a Human Multiple Myeloma Cell vs. Time

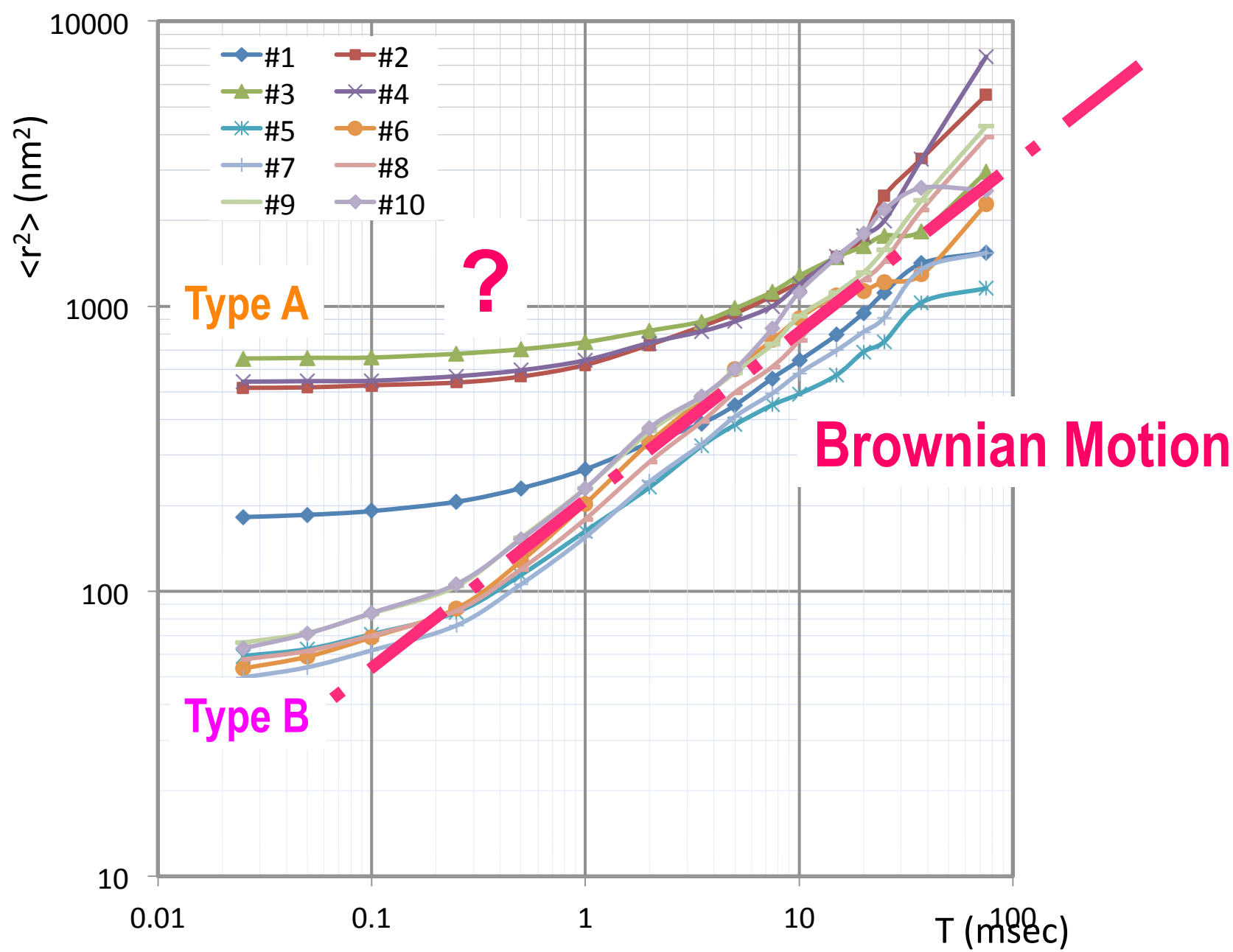

Campus-wide Collaborations on High-Speed Bio-imaging

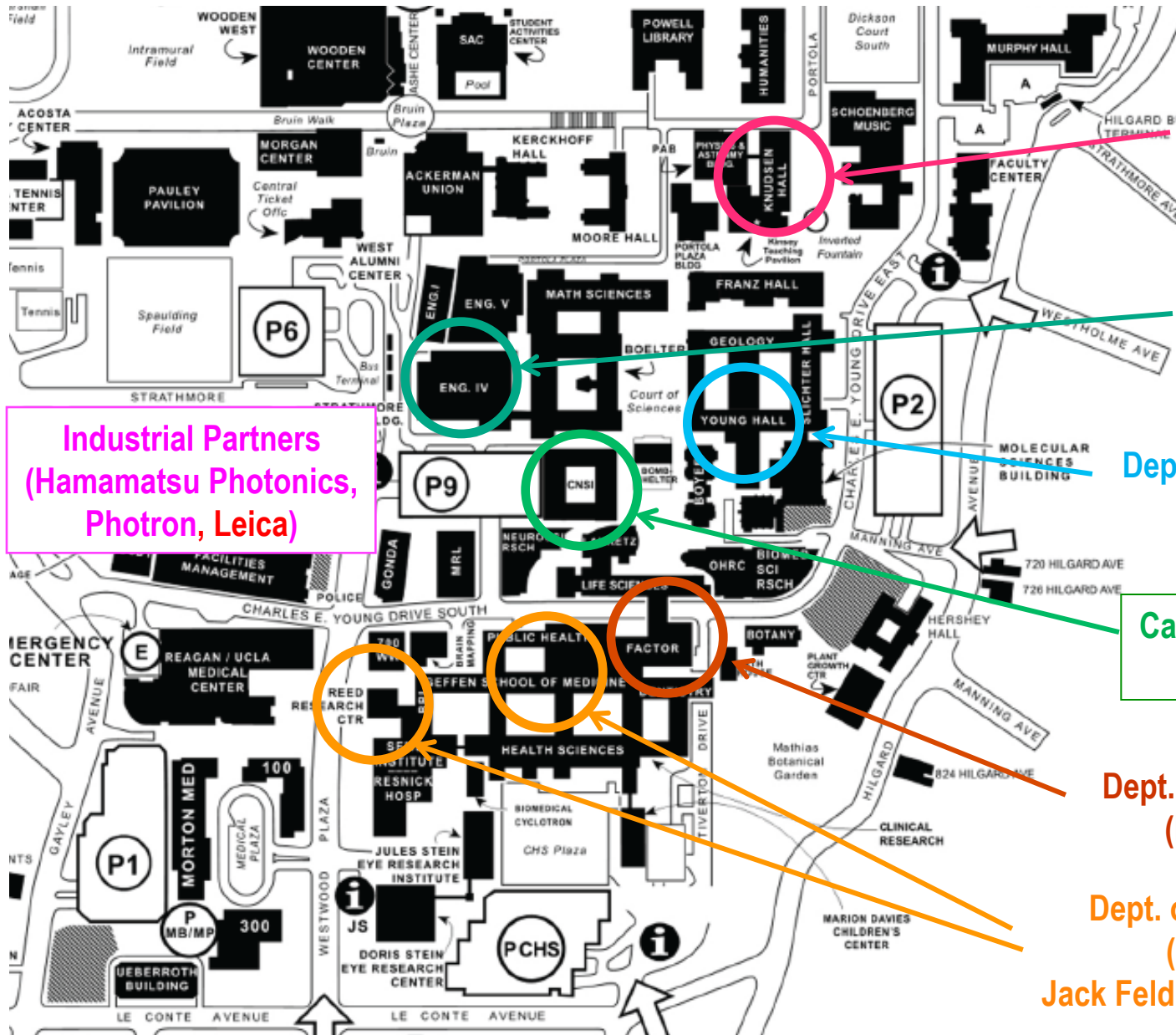

Dept. of Physics & Astronomy
(Dolores Bozovic, John Miao,
Mayank Mehta)

Dept. of Electrical Engineering
(Bahram Jalali)

Dept. of Chemistry & Biochemistry
(Shimon Weiss)

California Nano Systems Institute
(CNSI, Laurent Bentolila)

Dept. of Surgical Oncology
(Manuel Penichet)

Dept. of Neurology & Neurobiology
(Carlos Portera-Cailliau,
Jack Feldman, Tom Otis, Andrew Charles)

User-shared Core Facility of High-speed Microscopes at CNSI



4D Nano Biophysics

Image Intensified CMOS Camera

Photron

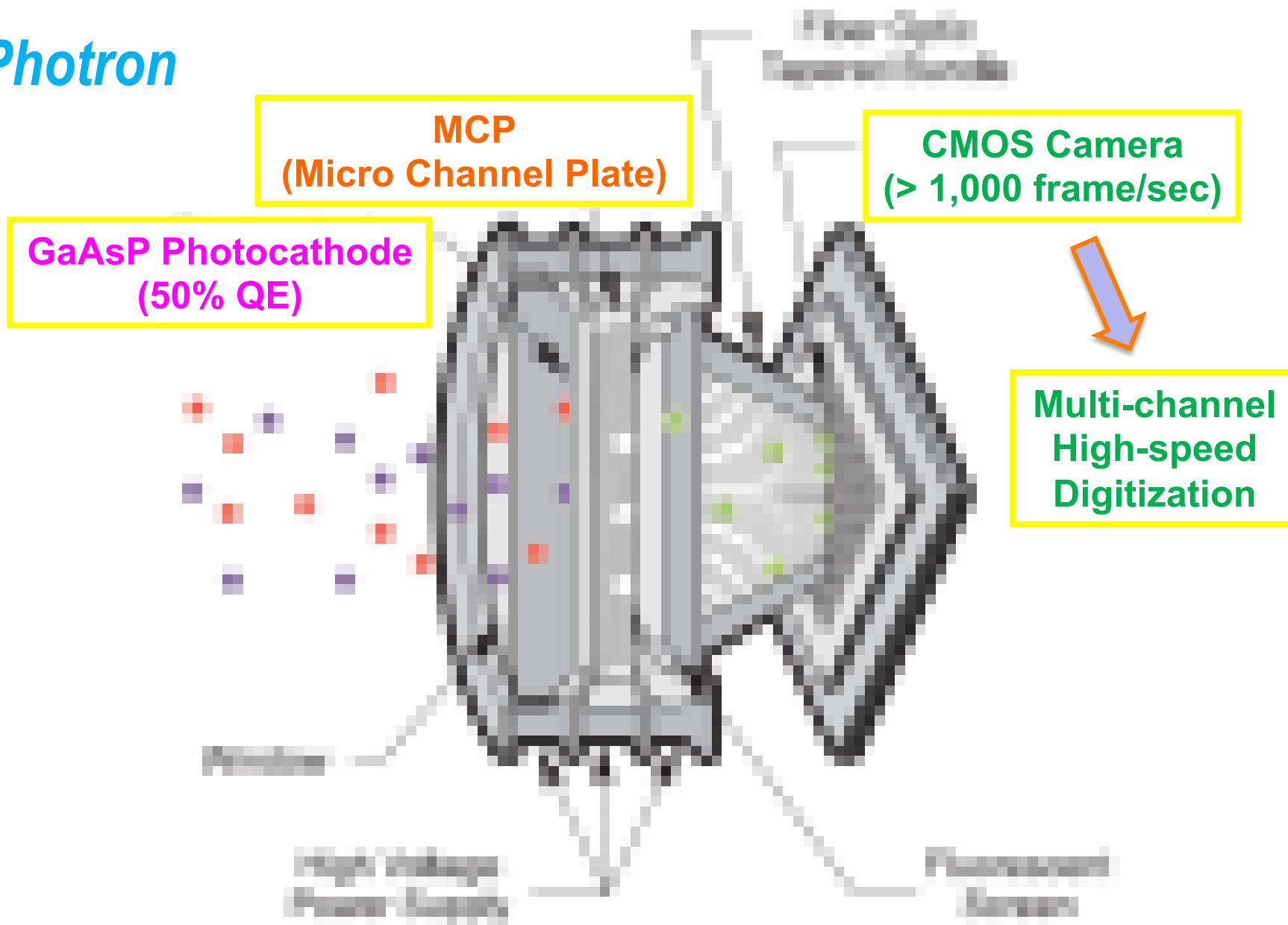

MCP (Micro Channel Plate)

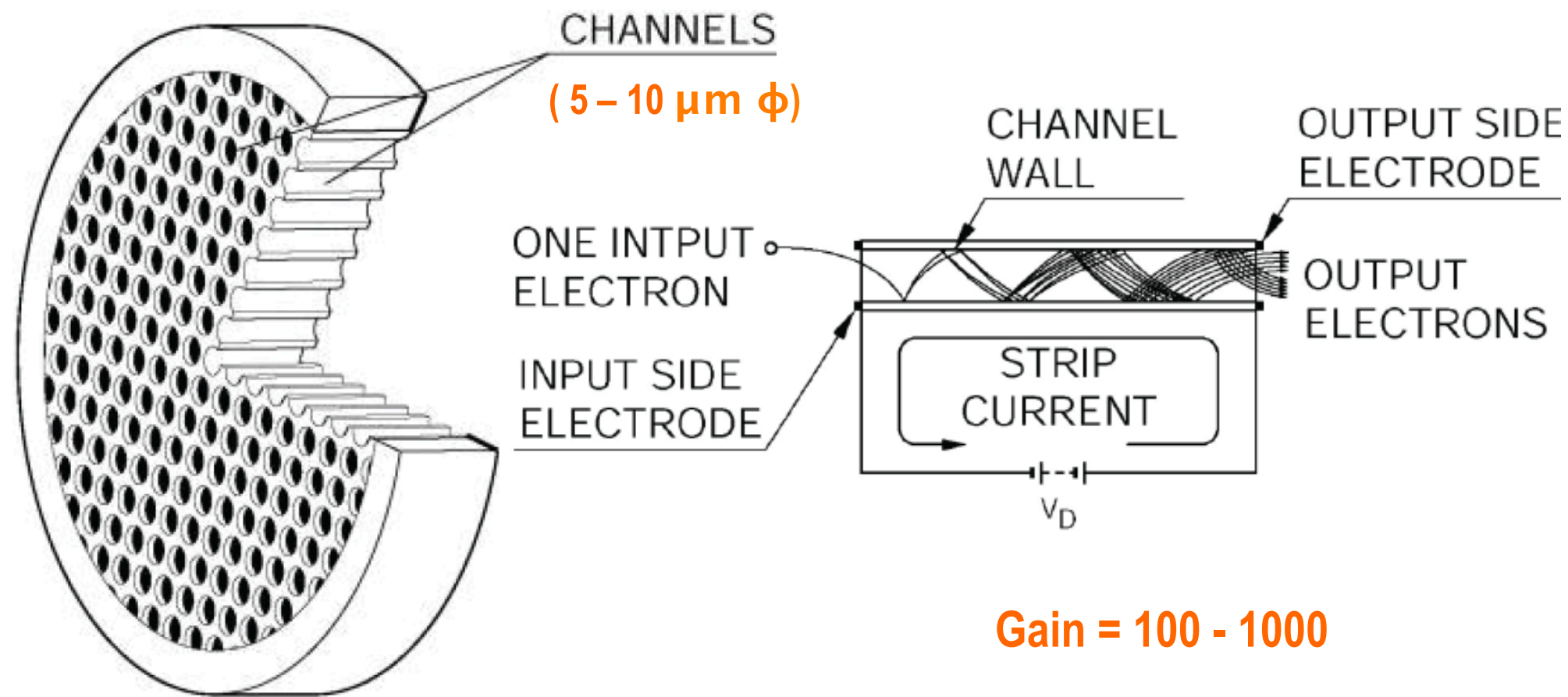

FocusScope SV200-i

Designed specifically for high speed microscopy, the *FocusScope SV200-i* incorporates the latest Generation III image intensifier technology to offer enhanced image resolution and broad spectral response

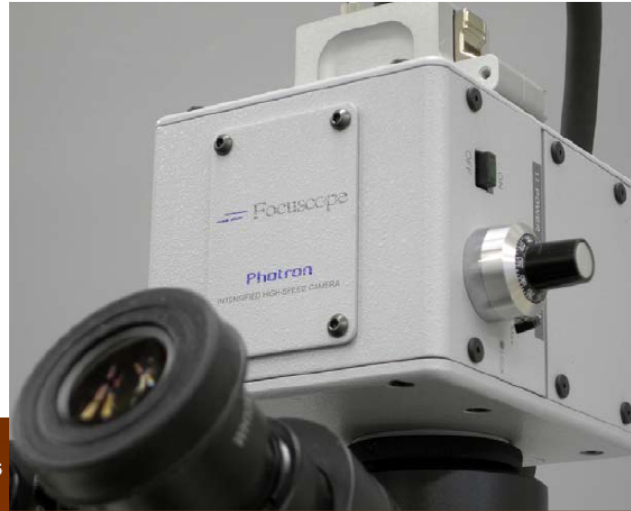

2,000 fps

Providing recording rates of up to 2,000fps at 512x512 pixel image resolution the FocusScope SV200-i utilizes the high resolution performance and broad spectral response of Generation III image intensifier technology to provide an integrated imaging solution for high speed microscopy applications.

To obtain the highest optical efficiency the FocusScope SV200-i camera head incorporates a 512x512 pixel advanced CMOS imaging sensor fiber-optically coupled to an 18mm Generation III image intensifier module. The camera head provides a C-mount thread for attachment to standard optical microscopes and objective lenses. Image intensifier controls are conveniently located on the camera head.

A single 6 meter cable connects the SV200-i camera head to a standard PCI format control card. Incorporated on the control card is 2.6GB recording memory allowing a recording time of 8.2 seconds at 1,000fps with 512x512 pixel image resolution.

System control is achieved through Photron *FASTCAM* Viewer software providing an intuitive operation environment. *FASTCAM* SDK software provided with the system allows user specific control commands to be integrated within other environments.

FEATURES

- System designed for extreme low light fluorescence and microscope recording at high frame rates.
- Advanced CMOS imaging sensor offering 512 x 512 pixel image resolution at frame rates up to 2,000frames per second.
- 10 bit sensor dynamic range.
- Global electronic shutter providing exposure durations from 1/frame rate to 4 μ s independent of frame rate.
- Extreme light sensitivity provided through a fiber optically coupled Generation III high resolution image intensifier. [luminous gain 2.2×10^4 (lm/m²)/lx]
- GaAsP photocathode providing broad spectral response over the range 280 – 720nm (peak sensitivity 530nm).
- Intensifier over brightness protection through phosphor surface current detection.
- Small and lightweight camera head suitable for integration with standard optical microscopes.
- User selectable Start, Centre, End and Manual trigger modes.
- Integrated system operation through *FASTCAM* Viewer control software and *FASTCAM* SDK.

Yokogawa CSU-X1

2,000 fps

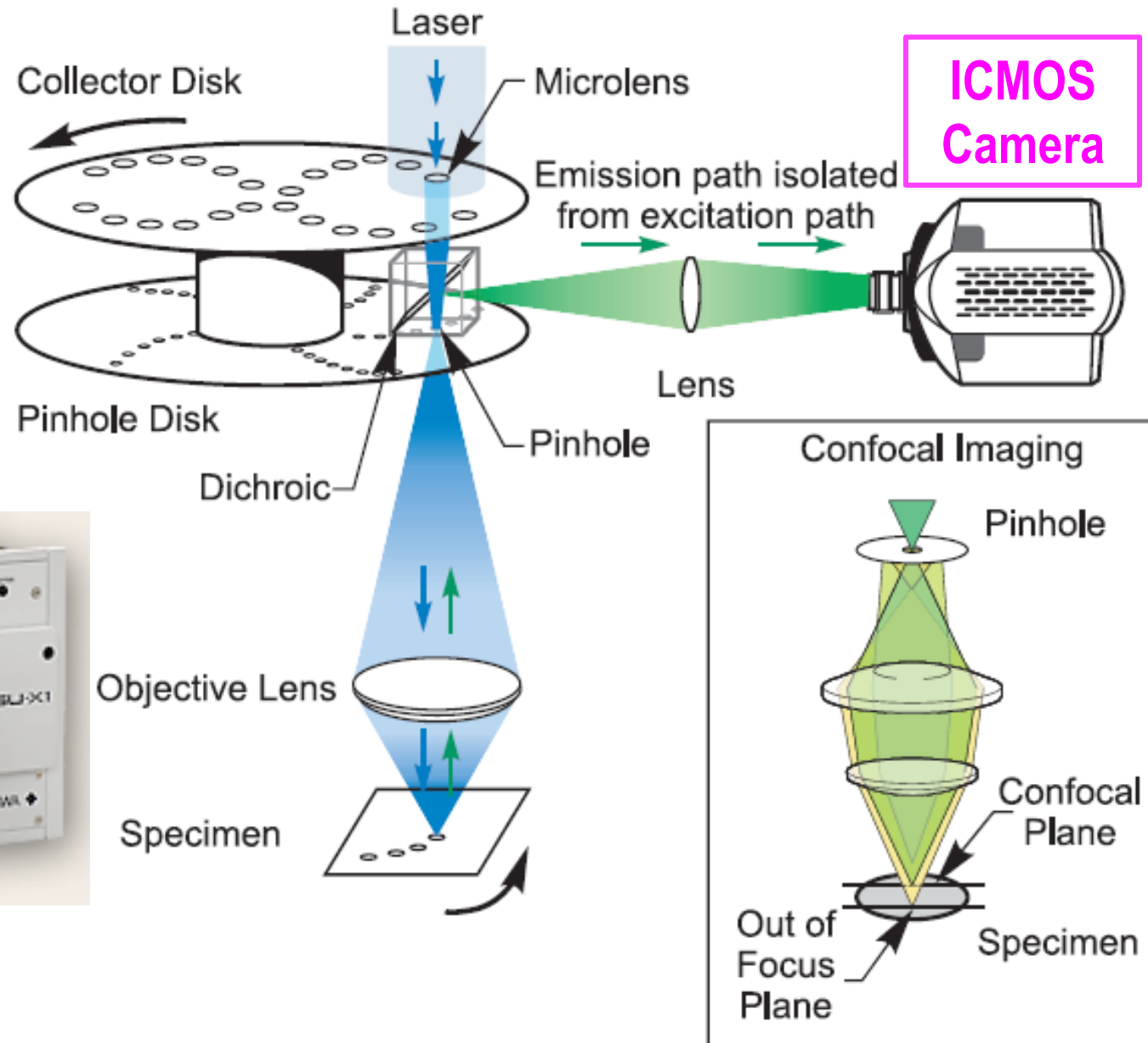

Confocal Dual Spinning Disk

High-speed Confocal Microscope with ICMOS at CNSI

(1,000 frame/s)

ICMOS Camera
(Photron SV200i)

Leica Microscope

EMCCD Camera
(Ando iXon 897)

Confocal Spinner
(Yokogawa CSU-X1)

Laurent Bentolila (CNSI)

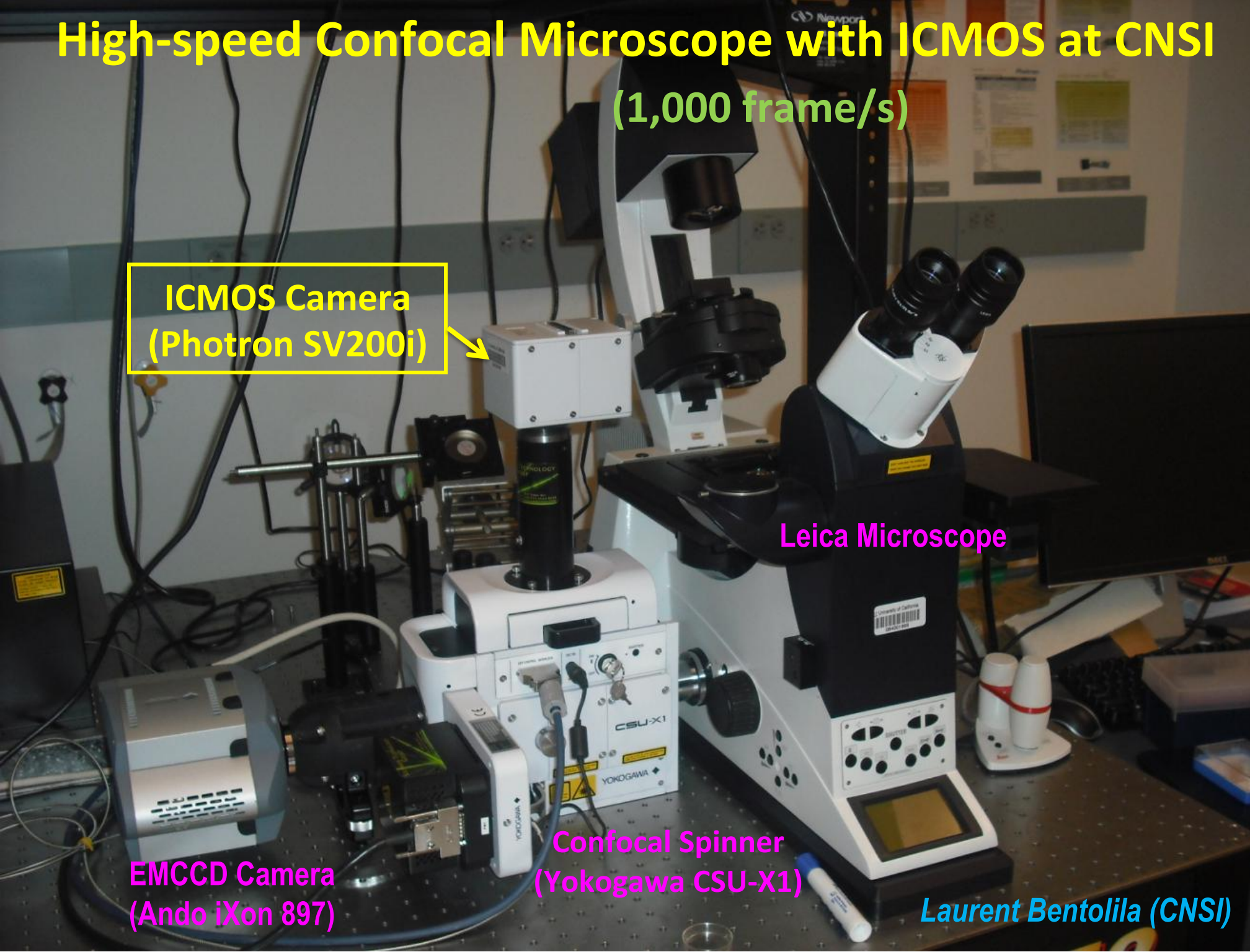

Frame Rate vs. Resolution

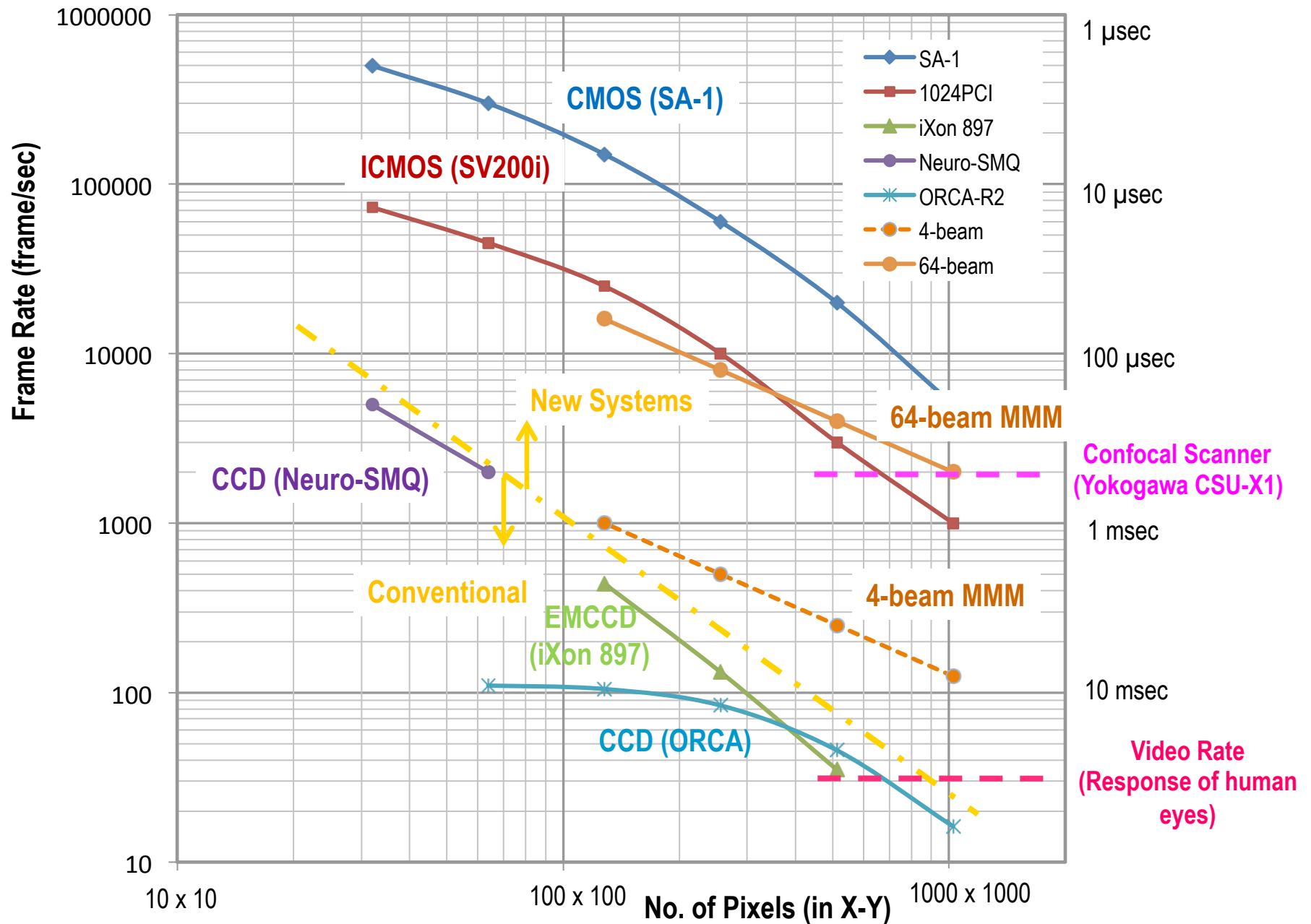

Imaging Flow Cytometer by Planar Illumination

Bahram Jalali (EE)

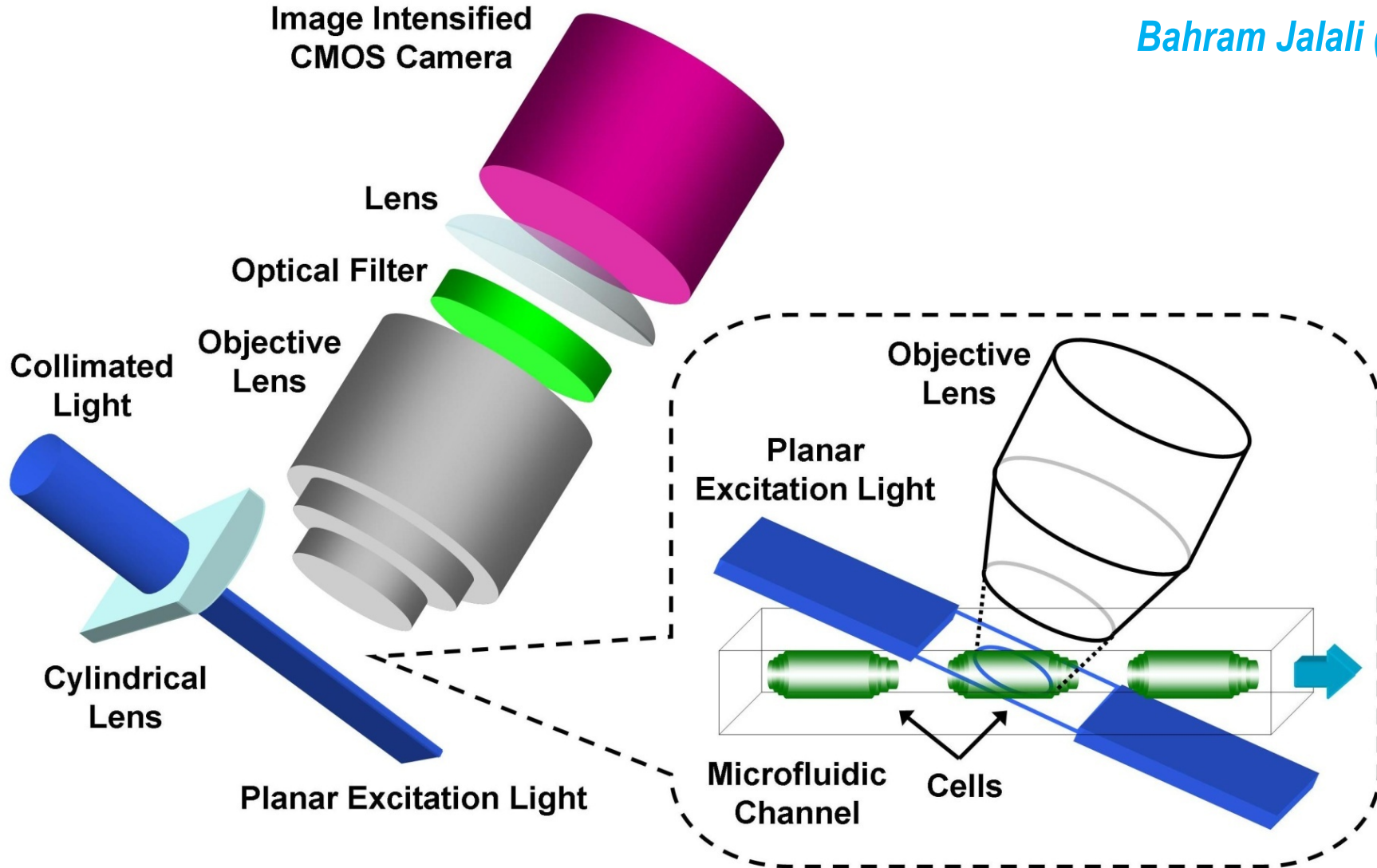

Speeding up evolution of life by accelerating mutations.

Origin of Consciousness

Brain

Universe

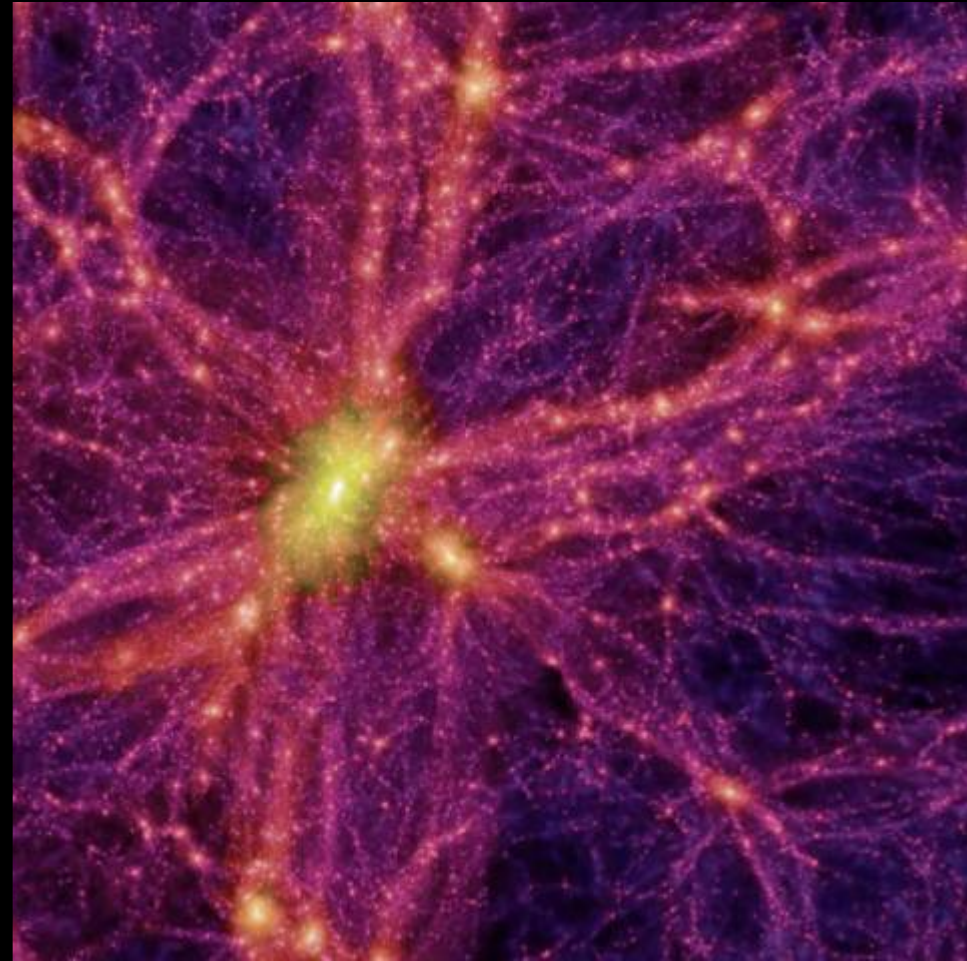
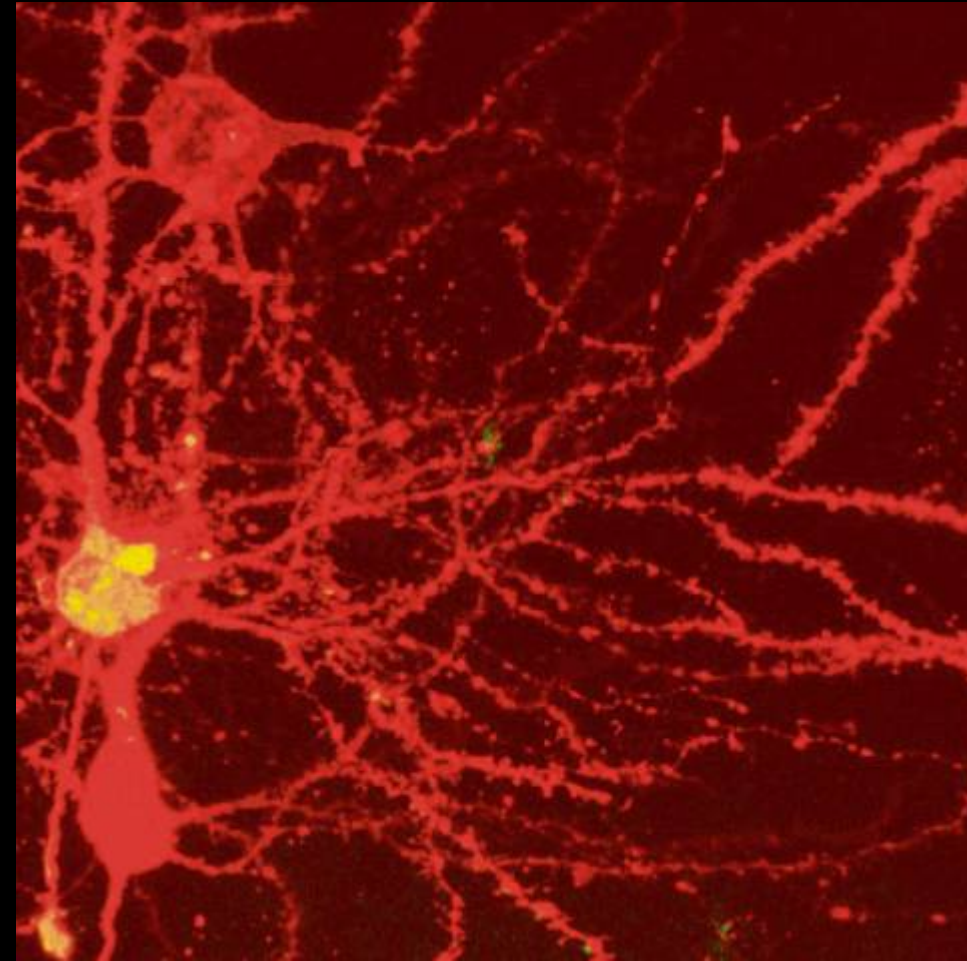

100 Billions Neurons

100 Billions Galaxies

Ca²⁺ Signal in cultivated Rat's Brain by Confocal Microscope

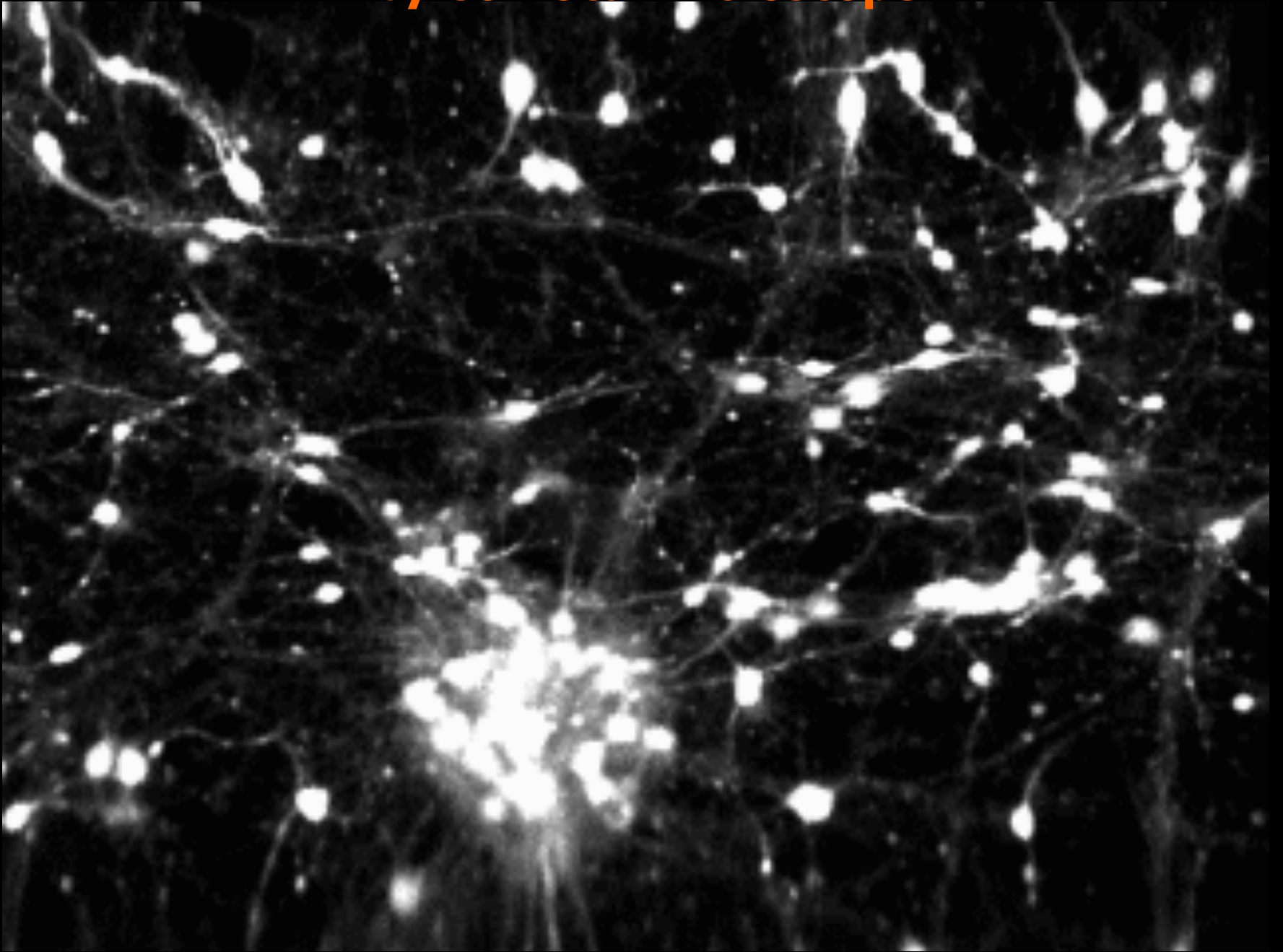

Andrew Charles (Neurobiology)

15 frame/sec

Neural Networks for Breathing

~300 neurons in rat's brain (pre-Botzinger Cells) responsible for breathing

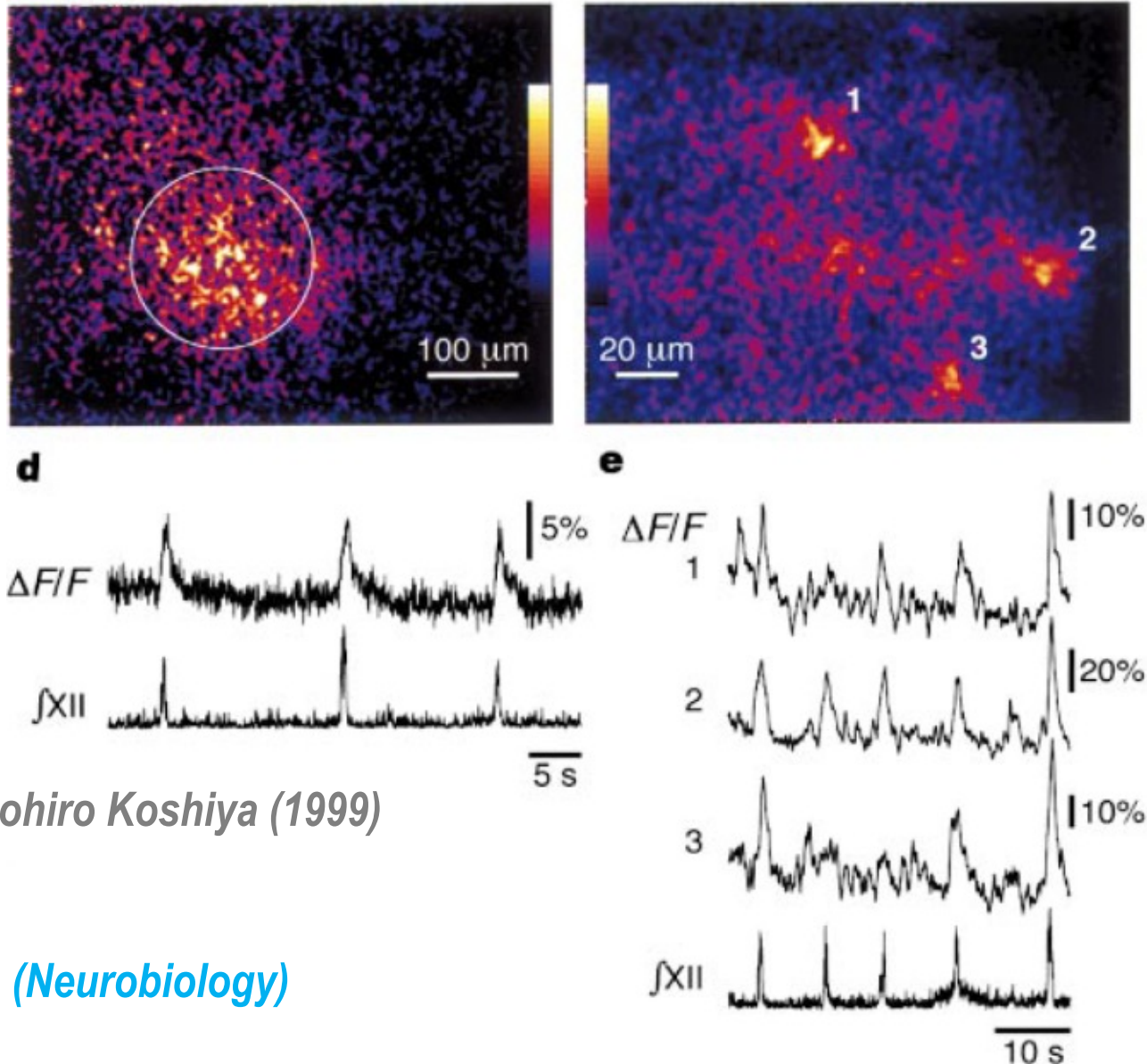

Nature by Naohiro Koshiya (1999)

Jack Feldman (Neurobiology)

High-speed Ca^{2+} Imaging of pre-Botzinger Cells of Rats

Jack Feldman (Neurobiology)

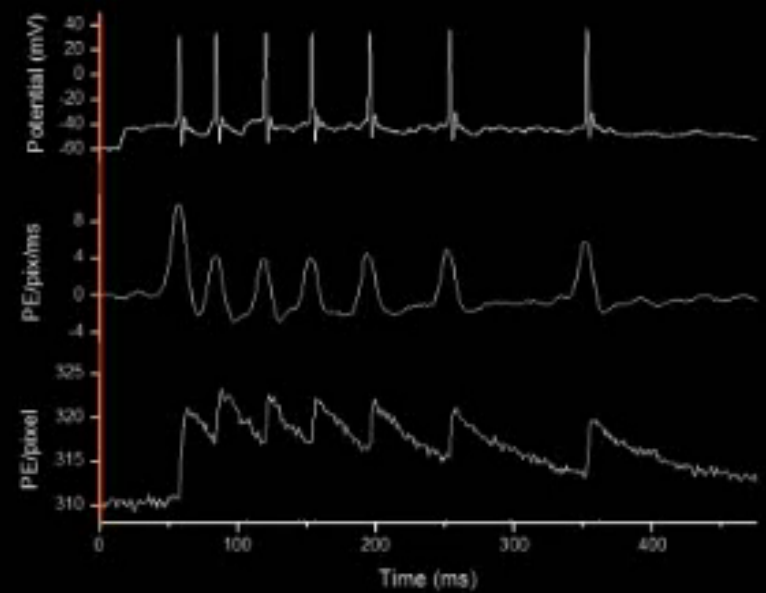
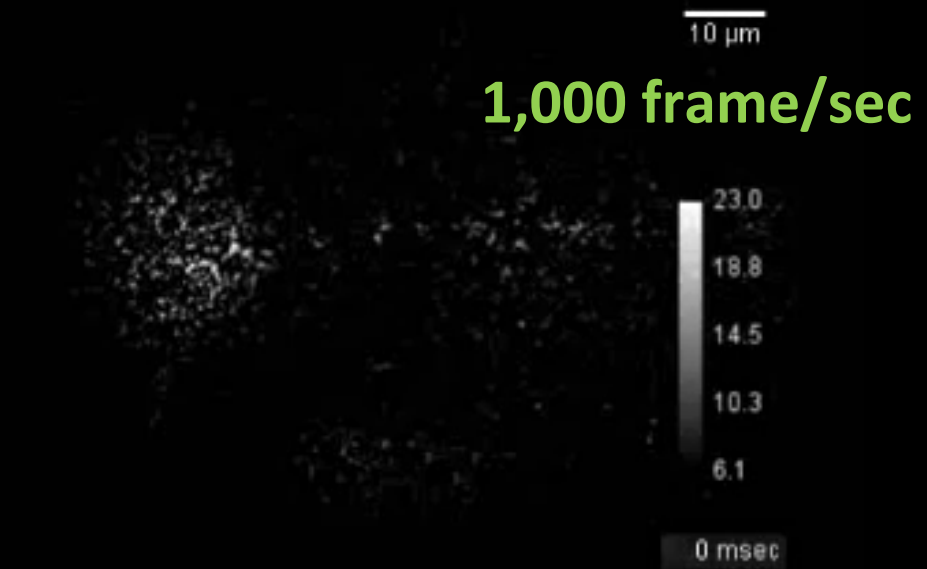

UCLA Ultra-fast Bio-imaging Group

C. Morgado, A. Cheng, L. Frederickson, K. Arisaka, J. Feldman

Sensory Input and Decision Making in Brain

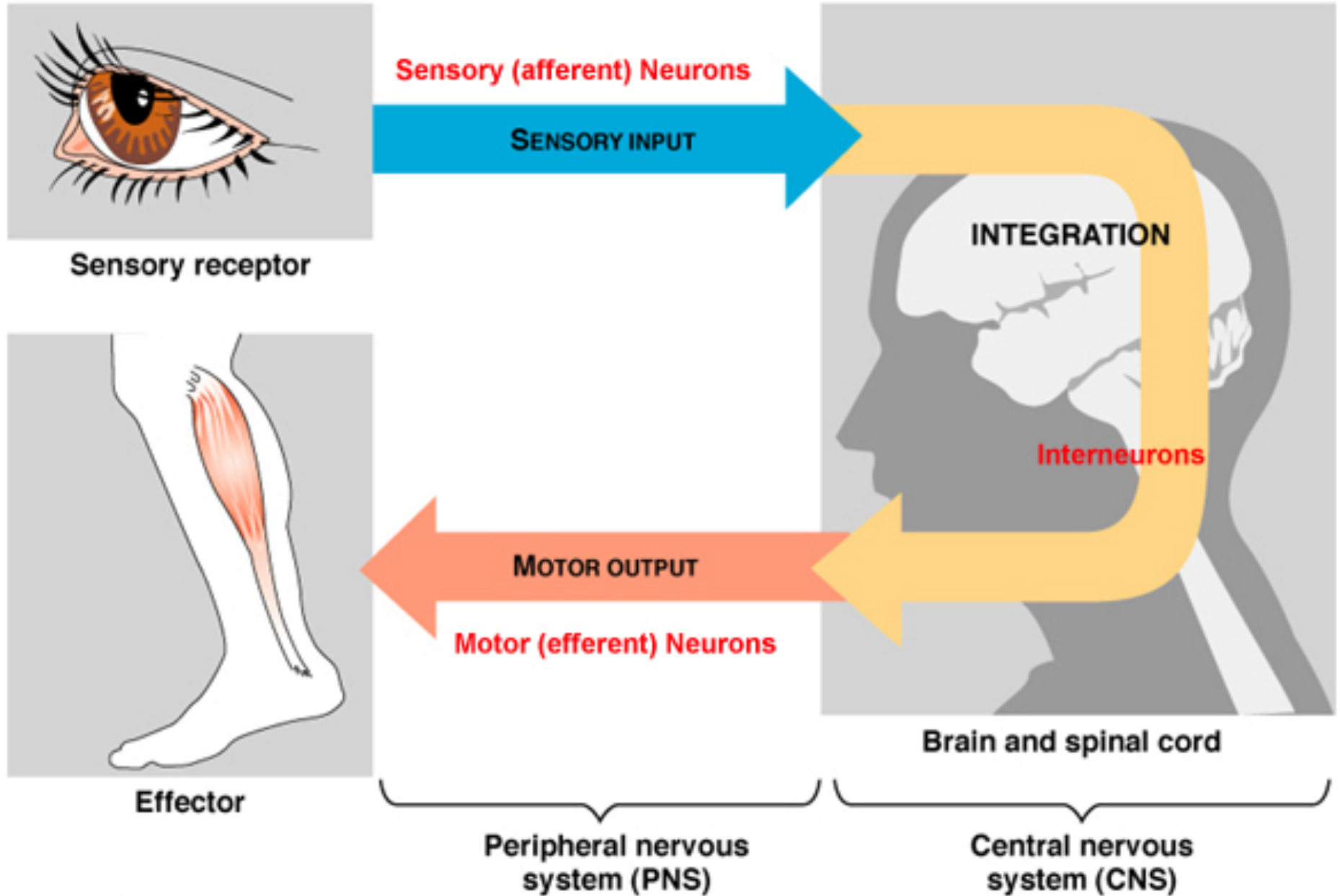

Anatomy of Inner Ear

Dolores Bozovic (Physics)

Human auditory system

Cross-section of the cochlear

Hair bundle

Molecular mechano-transduction machinery

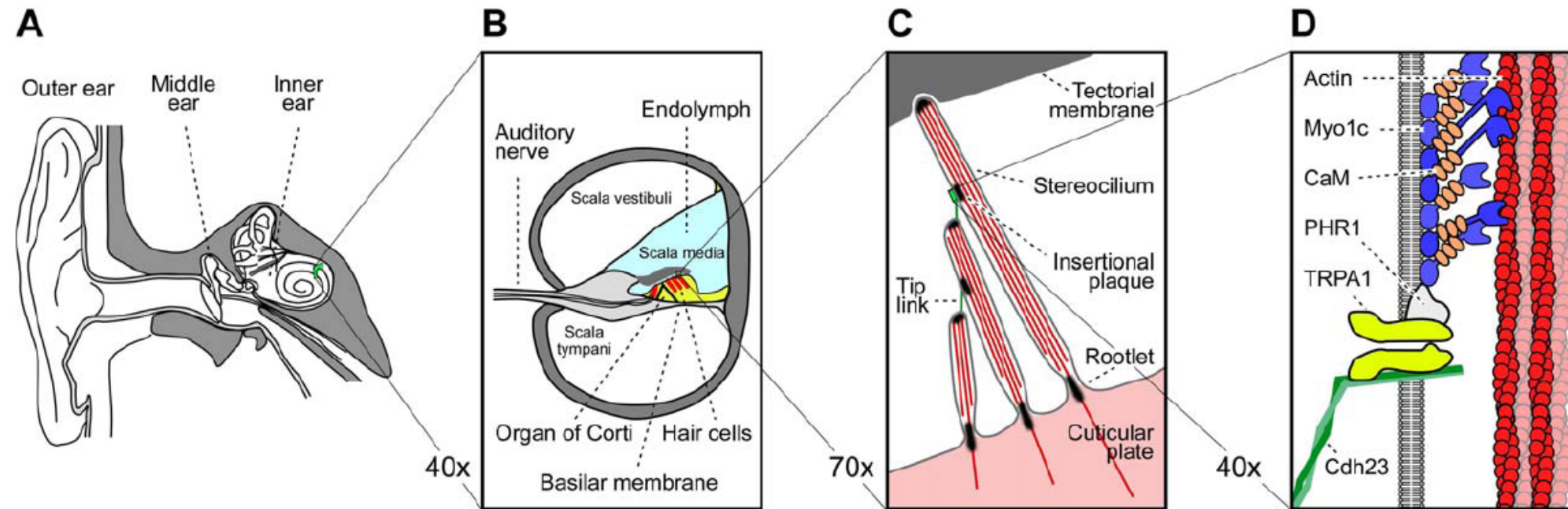

Meredith LeMasurier and Peter G. Gillespie, *Neuron*, Vol. 48, 2005

CMOS Camera
(Photron SA-1)

EMCCD Camera
(Andor iXon 897)

Microscopes

Objective

Dolores Bozovic's Lab (Physics)

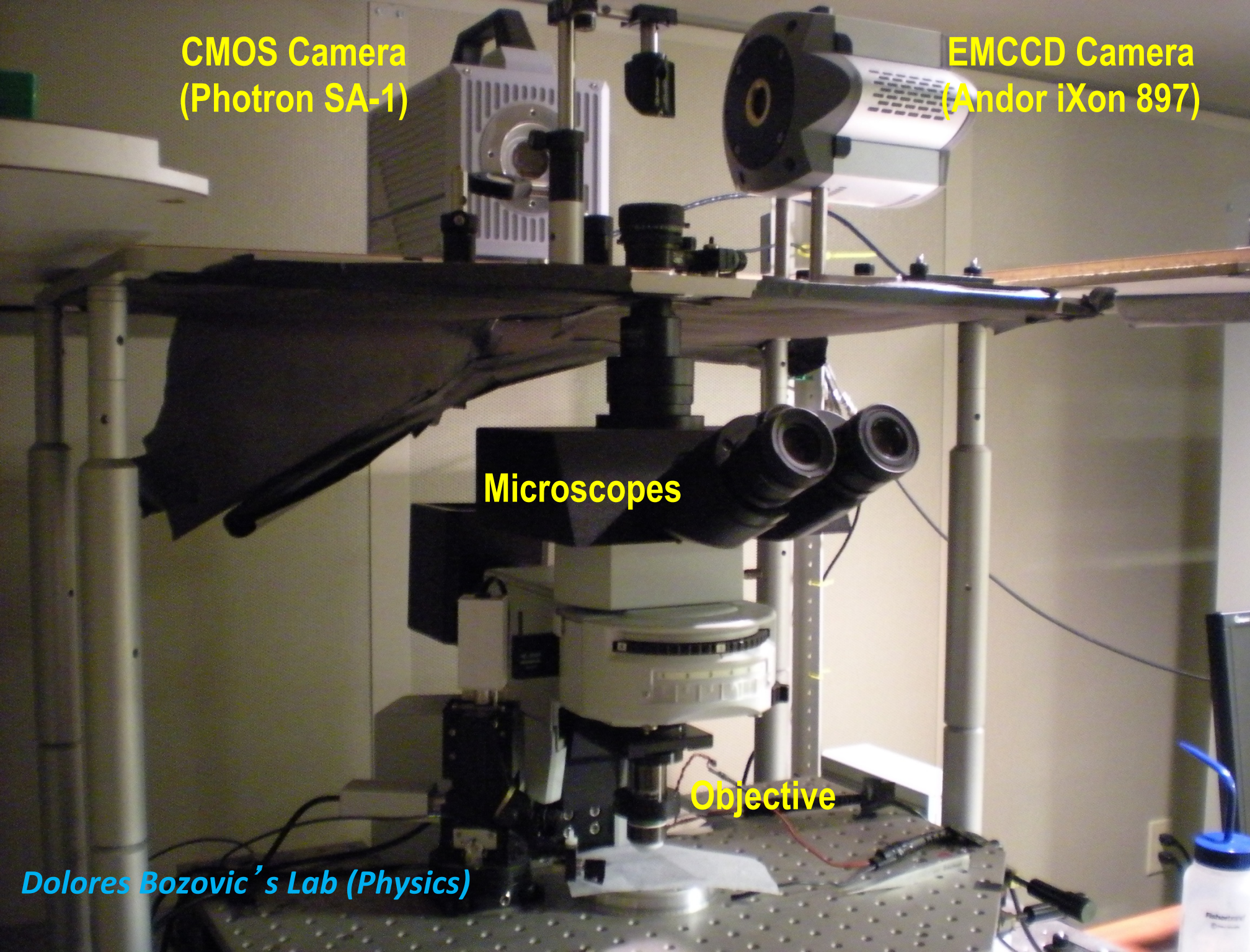

Mechanical Motion of Hair Cells in Inner Ear

Dolores Bozovic, Lea Fredrickson (Physics)

1,000 frame/sec

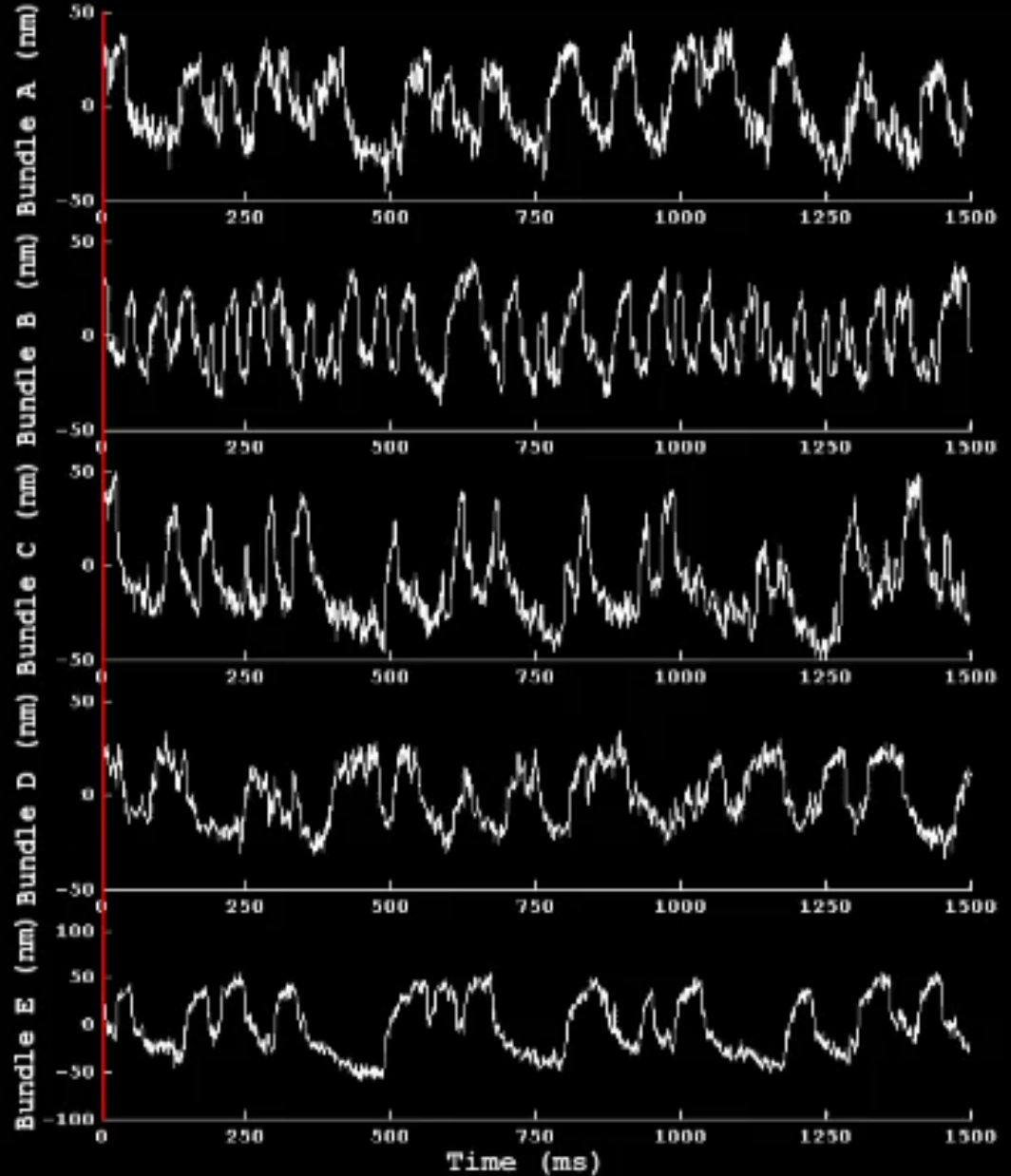
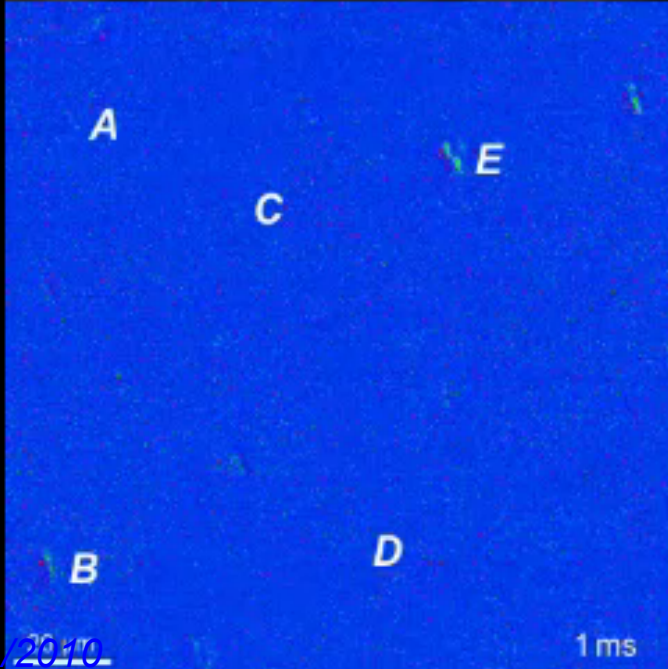
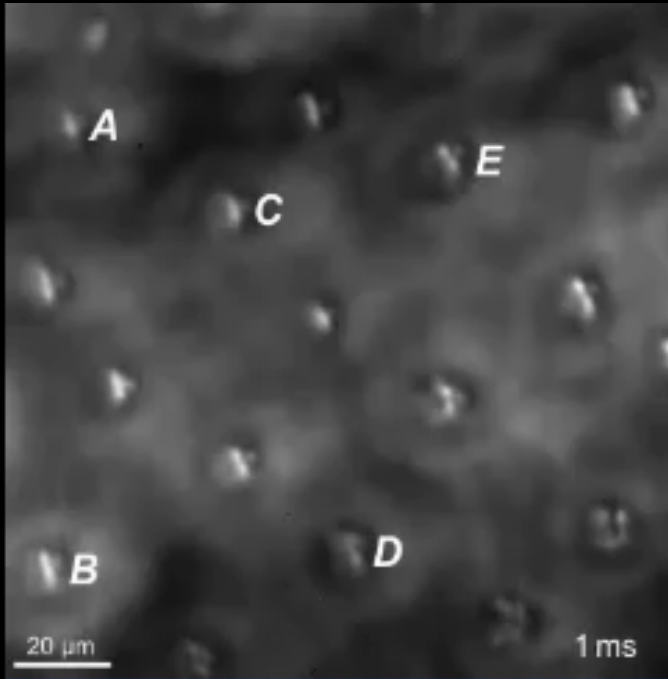

UCLA Fast Bio-Imaging Group

L. Fredrickson, A. Cheng, J. C. Jewhurst, C. E. Stimbu, D. Bozovic, K. Arisaka

How can I recognize a woman so far away?



- Genetically encoded?
- Learning and memory?

Nature vs. Nurture

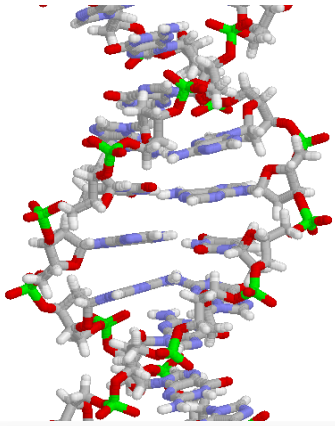

Nature

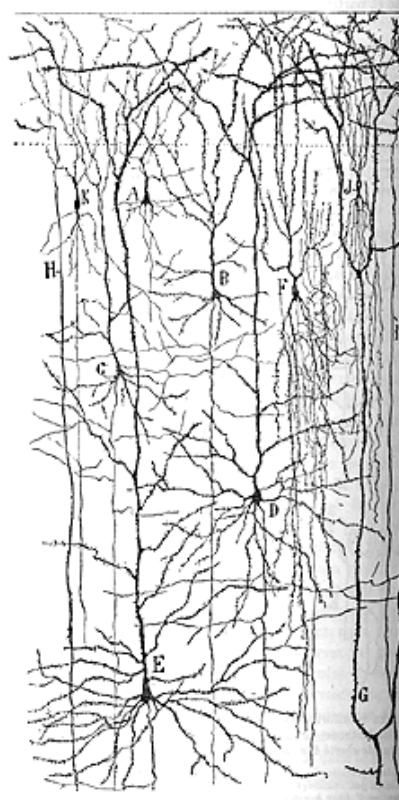

Nurture

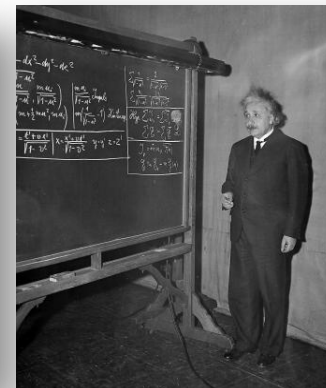
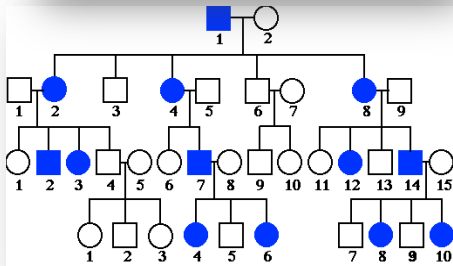
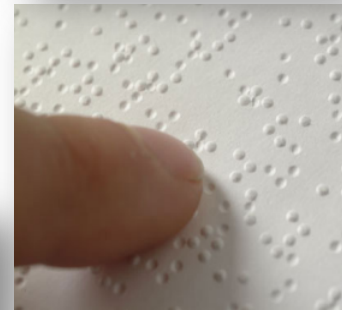

The Cerebral Cortex

Conscious
↑

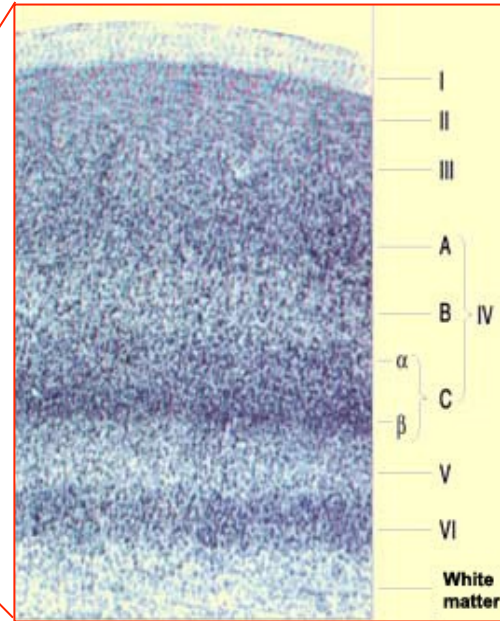
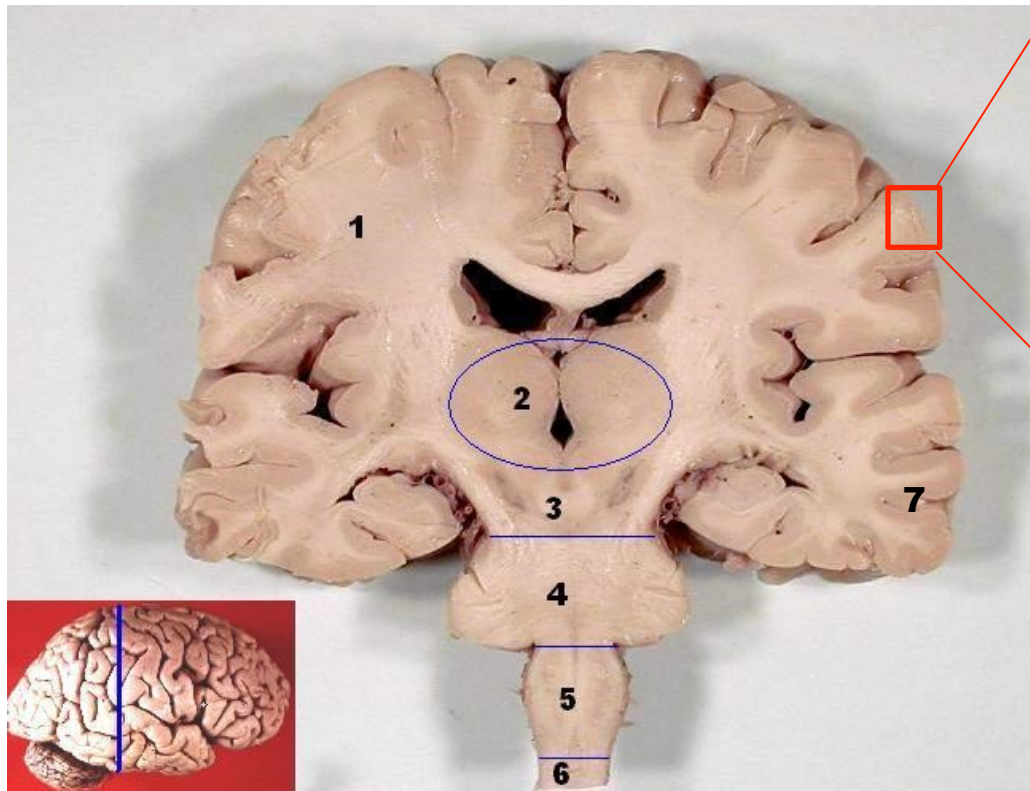

↓
Unconscious

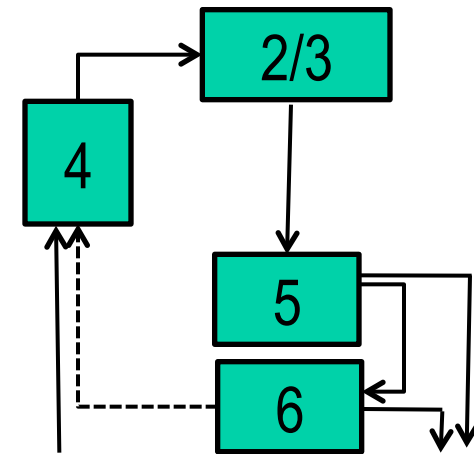

Thalamus

Subcortical areas

Assembly of rat's cortical circuits during development

How/when do neurons establish networks? → *Symmetry Breaking*

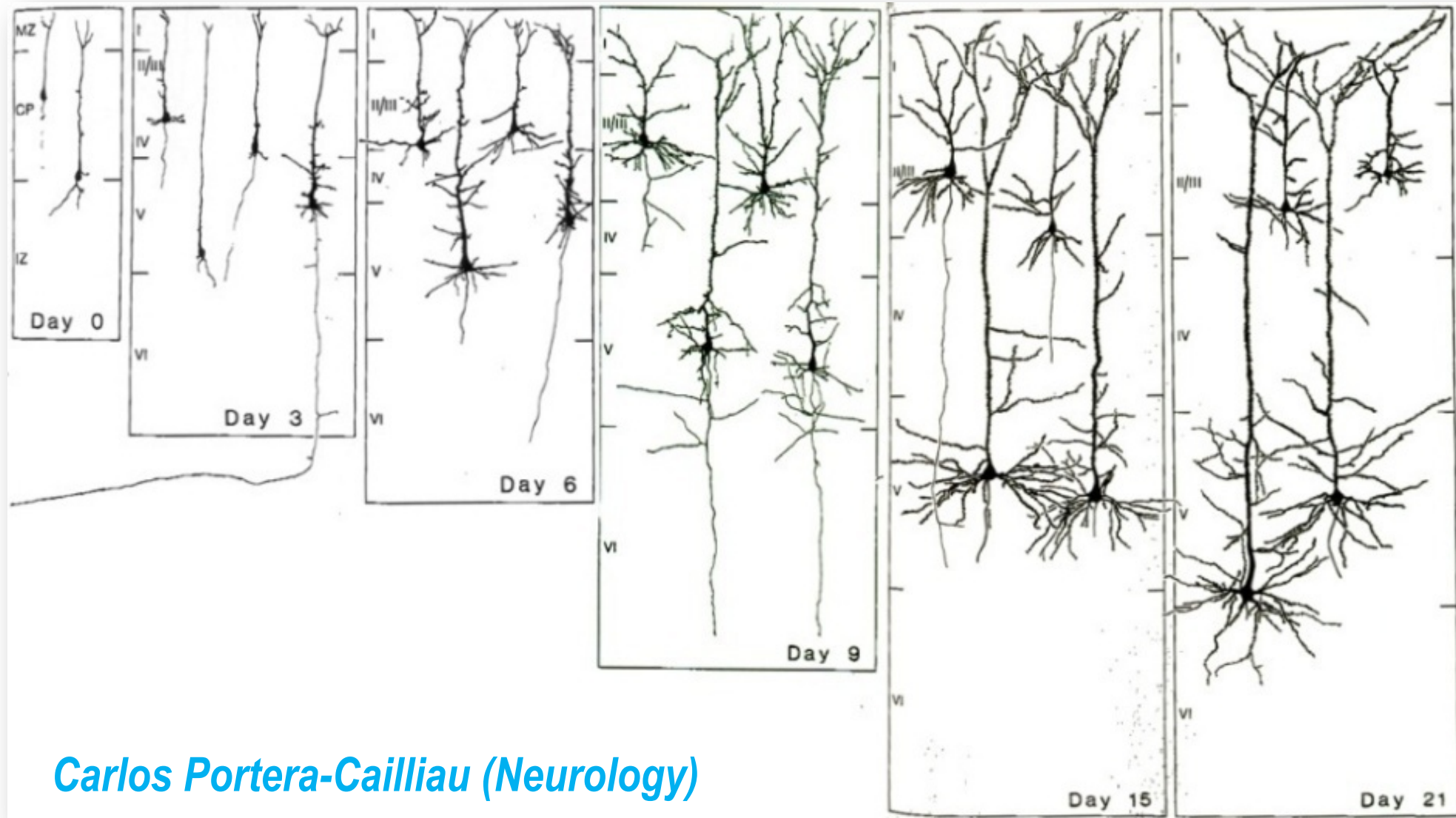

Spatio-Temporal Excitation-Emission Multiplexing (STEM) Microscope

Adrian Cheng (Physics)

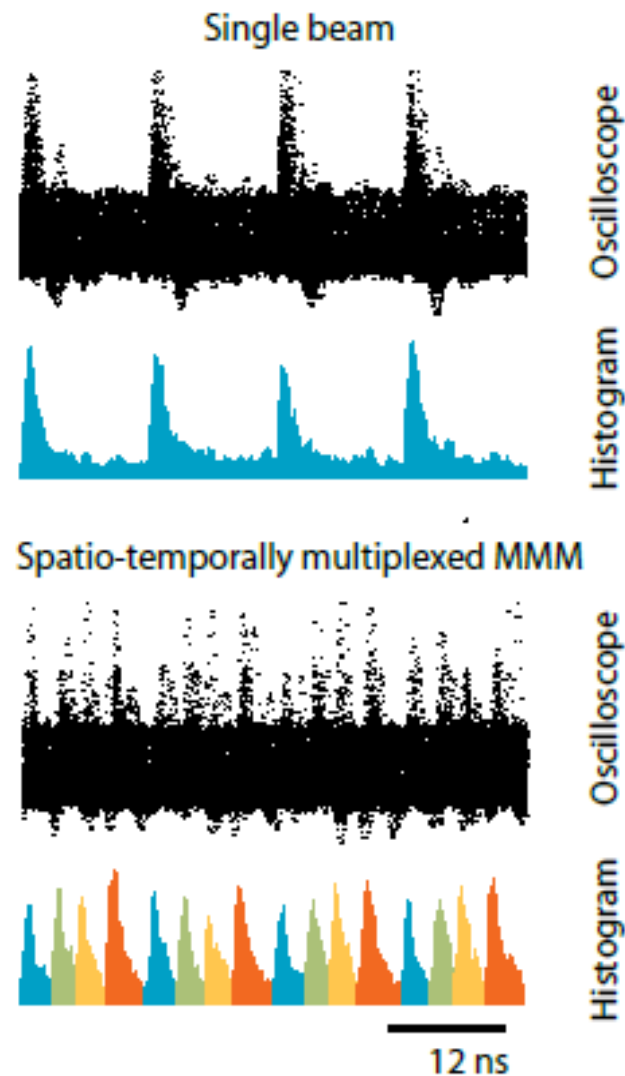
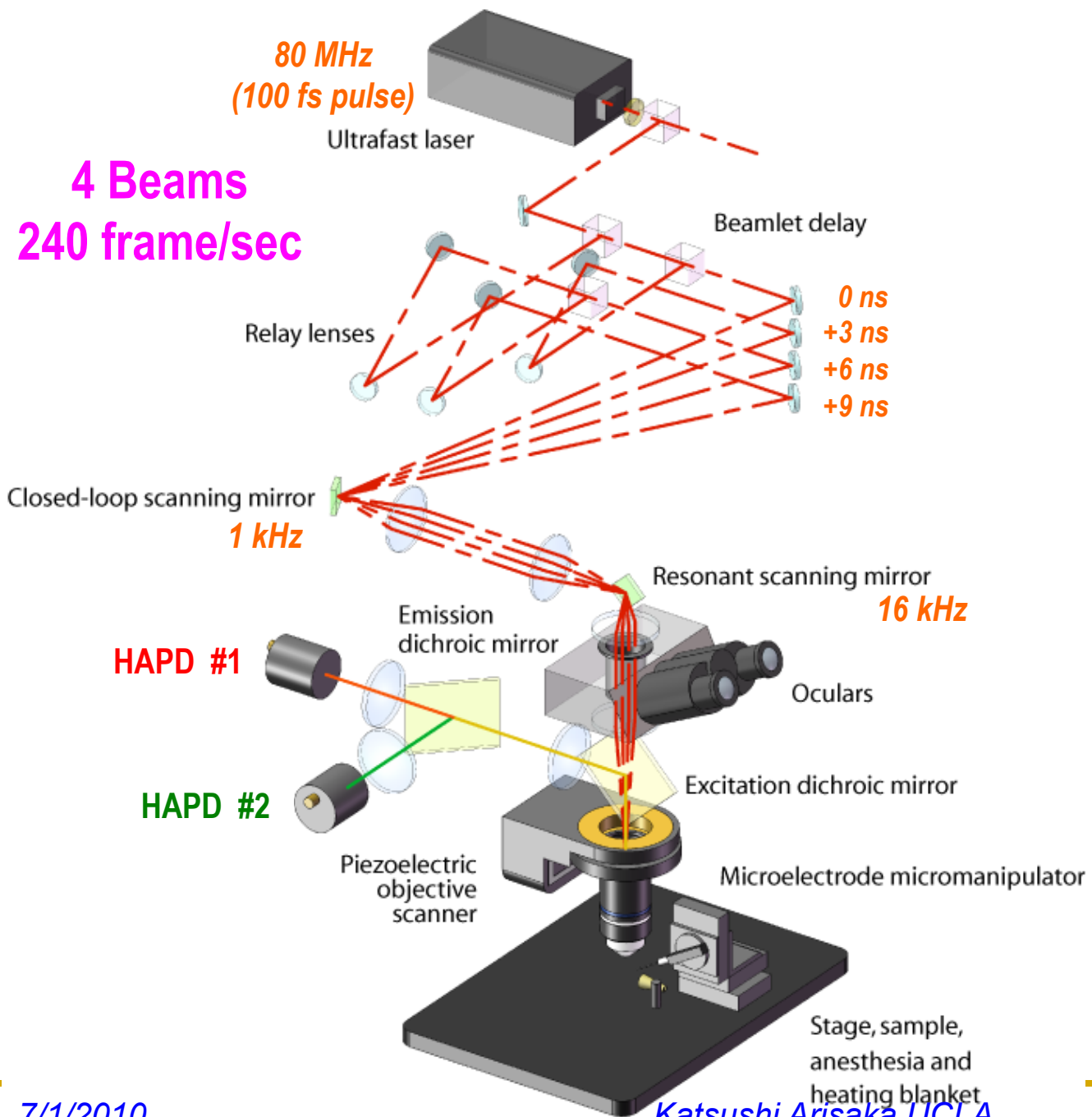

In vivo calcium imaging of neuronal activity

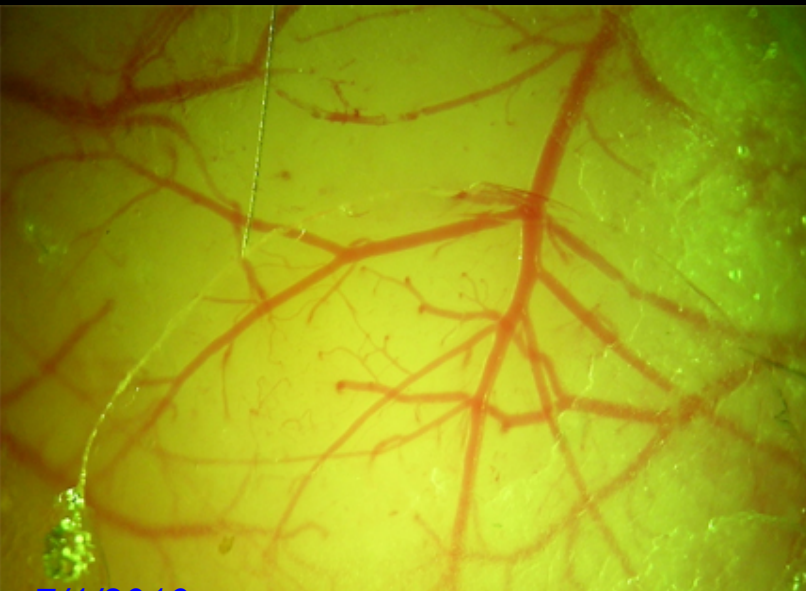
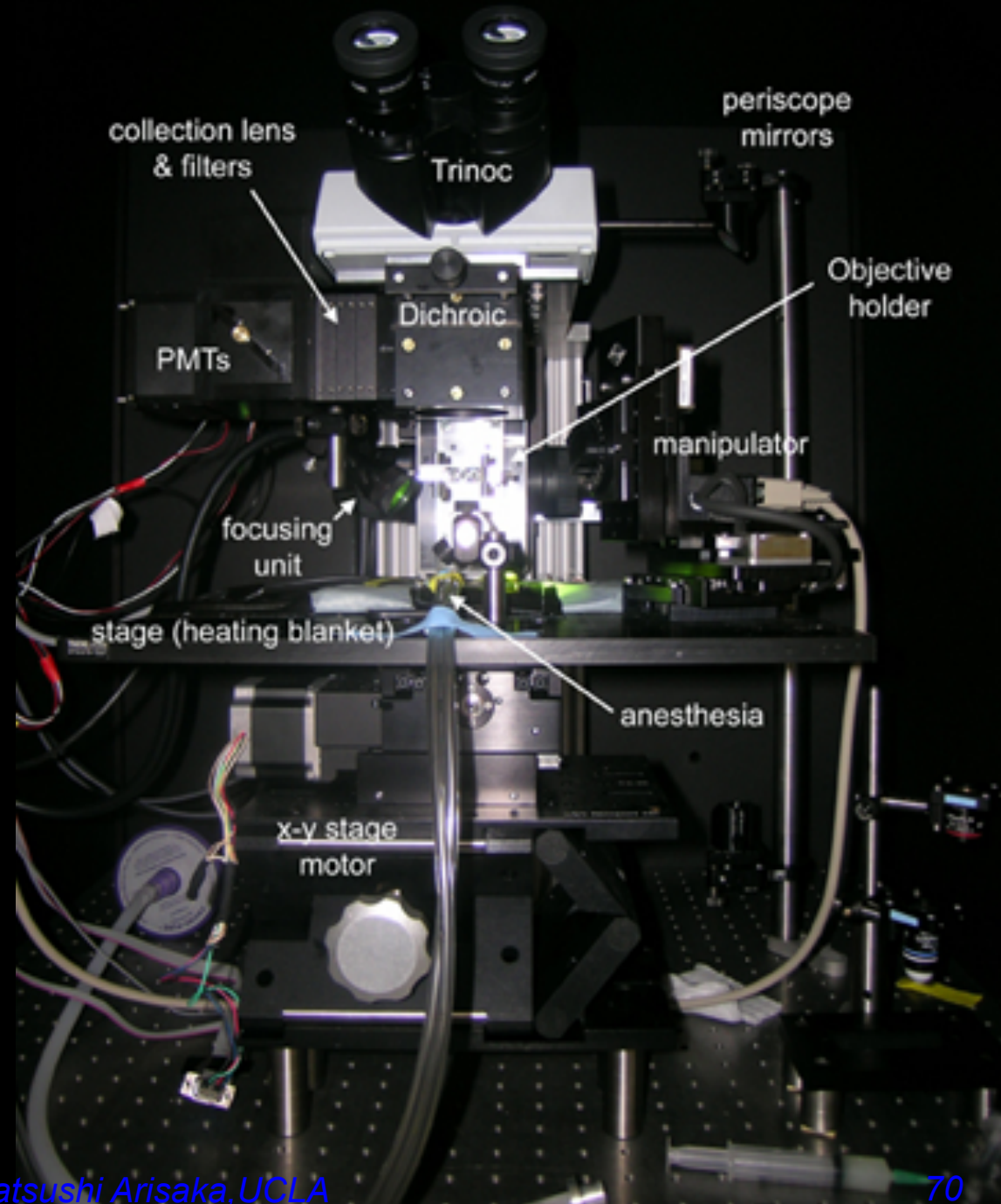
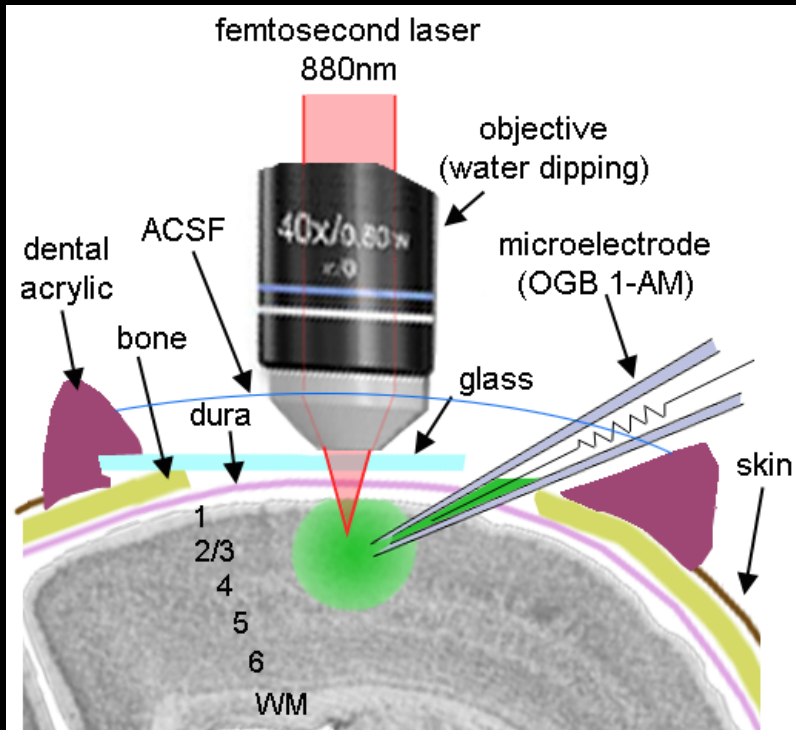

Fluo-4 AM labeled astrocytes are colabeled with sulforhodamine 101 to eliminate background (yellow)

Glass microelectrode for dye injection and electrophysiology

- cell-attached voltage follower
- whole-cell voltage/current clamp
- $10^{15} \Omega$ input impedance, $< 150 \text{ fA}$ input current bias

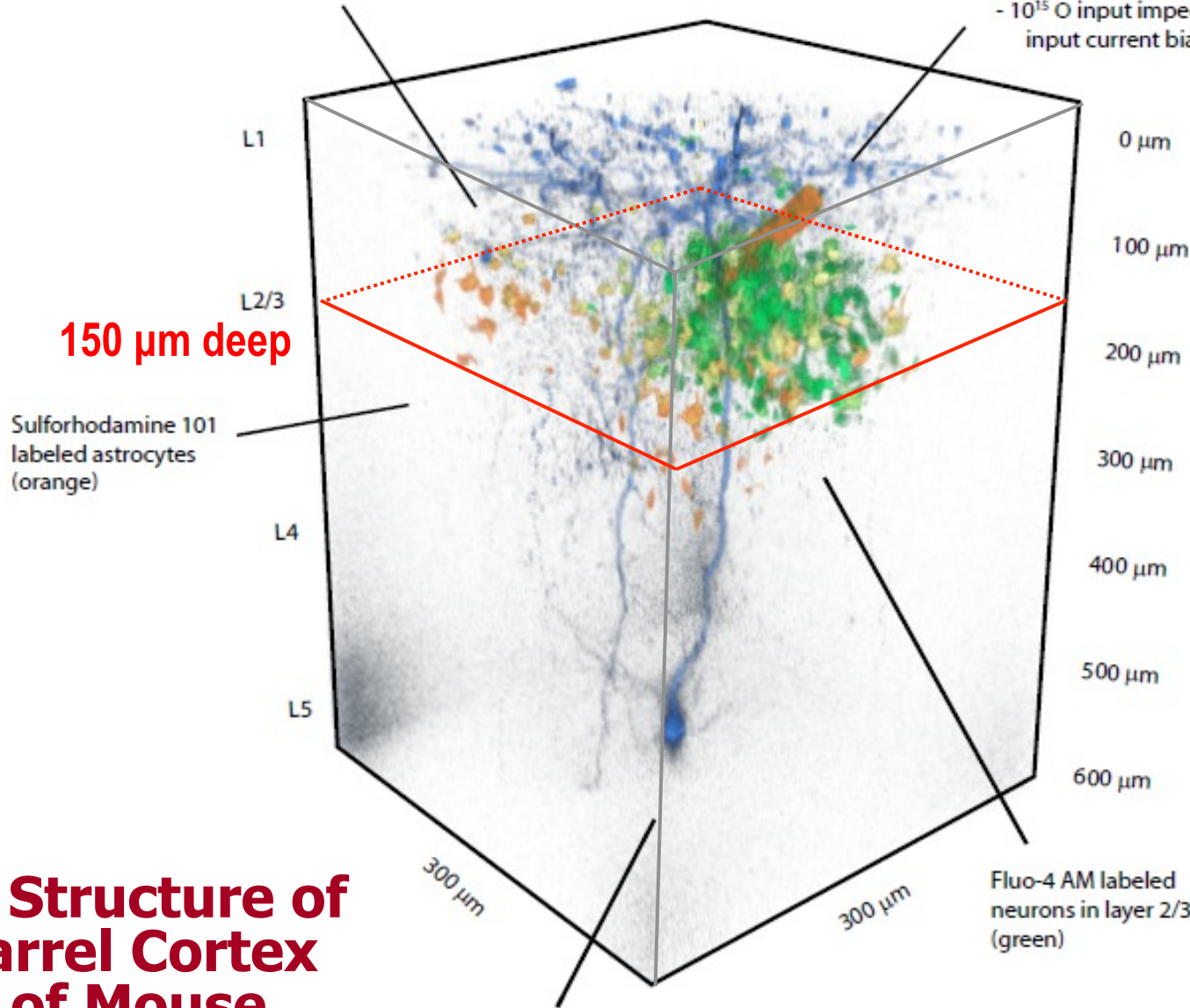

150 μm deep

Sulforhodamine 101 labeled astrocytes (orange)

Fluo-4 AM labeled neurons in layer 2/3 (green)

Layer 5 pyramidal neuron soma and apical dendrite from a transgenic animal demonstrates imaging depth (blue)

Adrian Cheng
(Physics)

Tiago Goncalves,
Peyman Golshani,
Carlos Portera-Cailliau
(Neurology)

3D Structure of Barrel Cortex of Mouse

In vivo calcium imaging with STEM

**Barrel Cortex
Layer 2/3**

150 μm deep

**240 fps
Raw Data**

**(x3 faster
than real)**

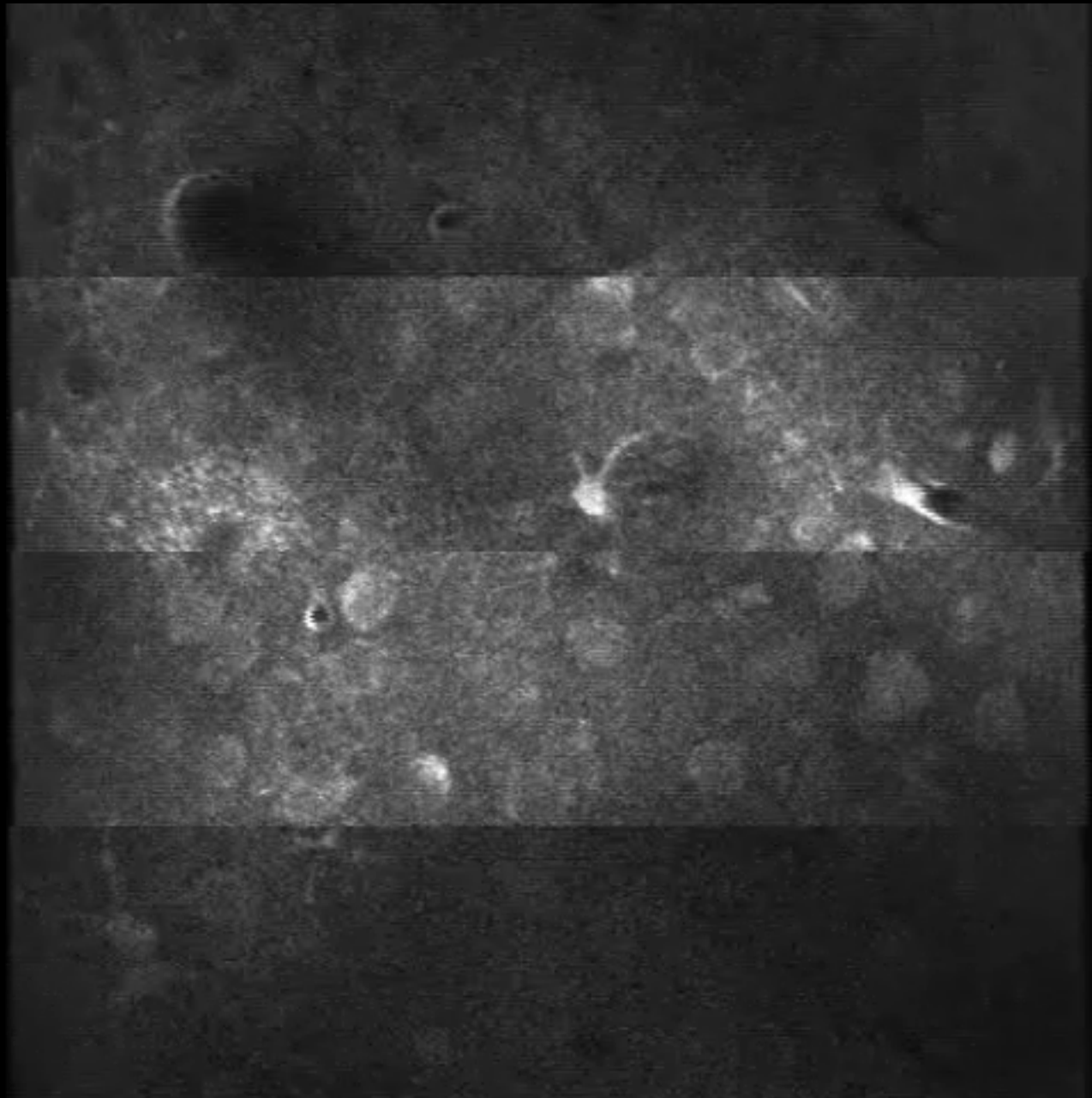

**Beam 1
(0 ns)**

**Beam 2
(+3 ns)**

**Beam 3
(+6 ns)**

**Beam 4
(+9 ns)**

In vivo calcium imaging with STEM

**Barrel Cortex
Layer 2/3**

150 μm deep

After averaging

**(x3 faster
than real)**

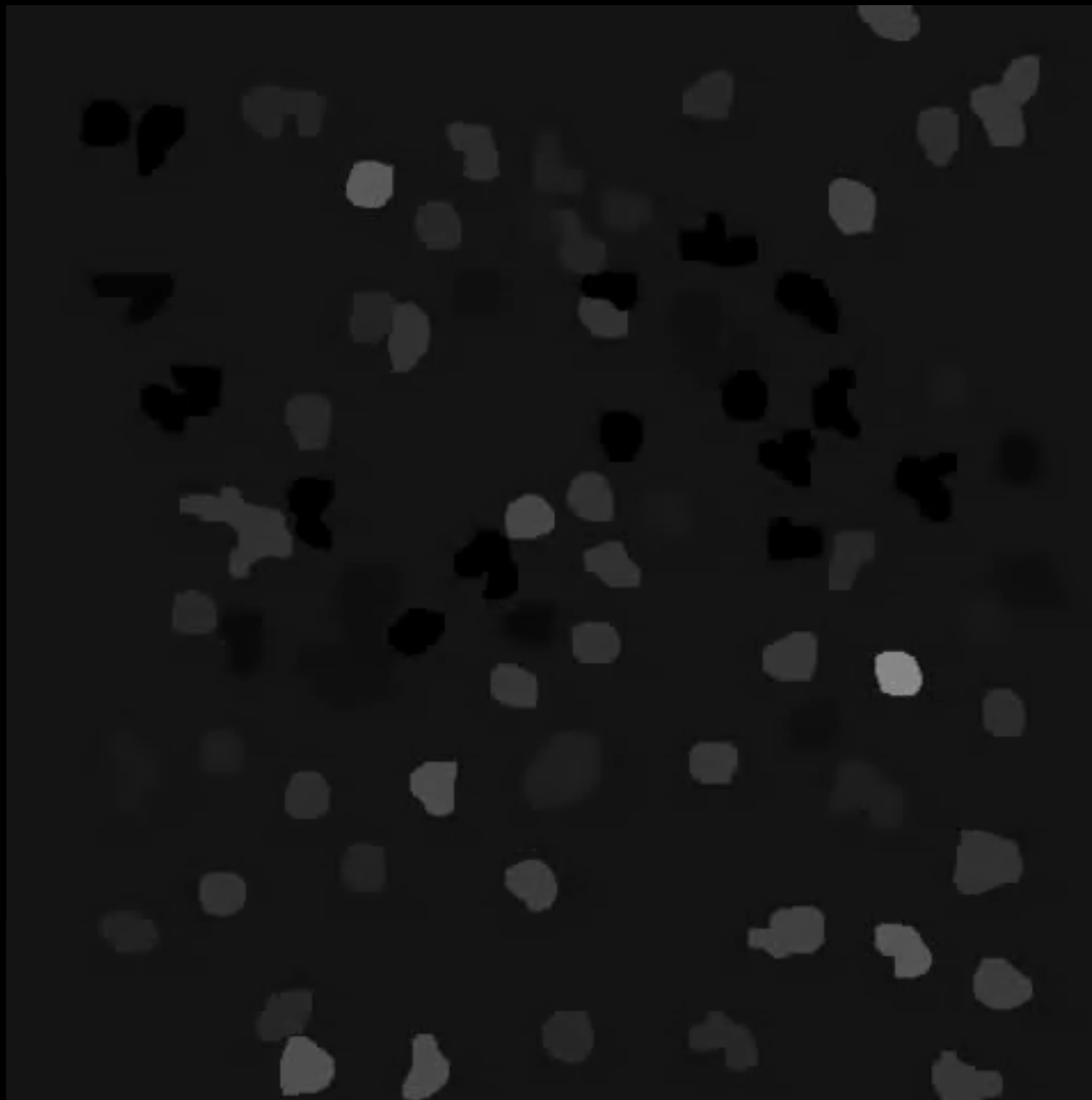

58 neurons
**(~100 billions
neurons
in our brain)**

In vivo calcium imaging of layer 2/3 neurons in barrel cortex with STEM

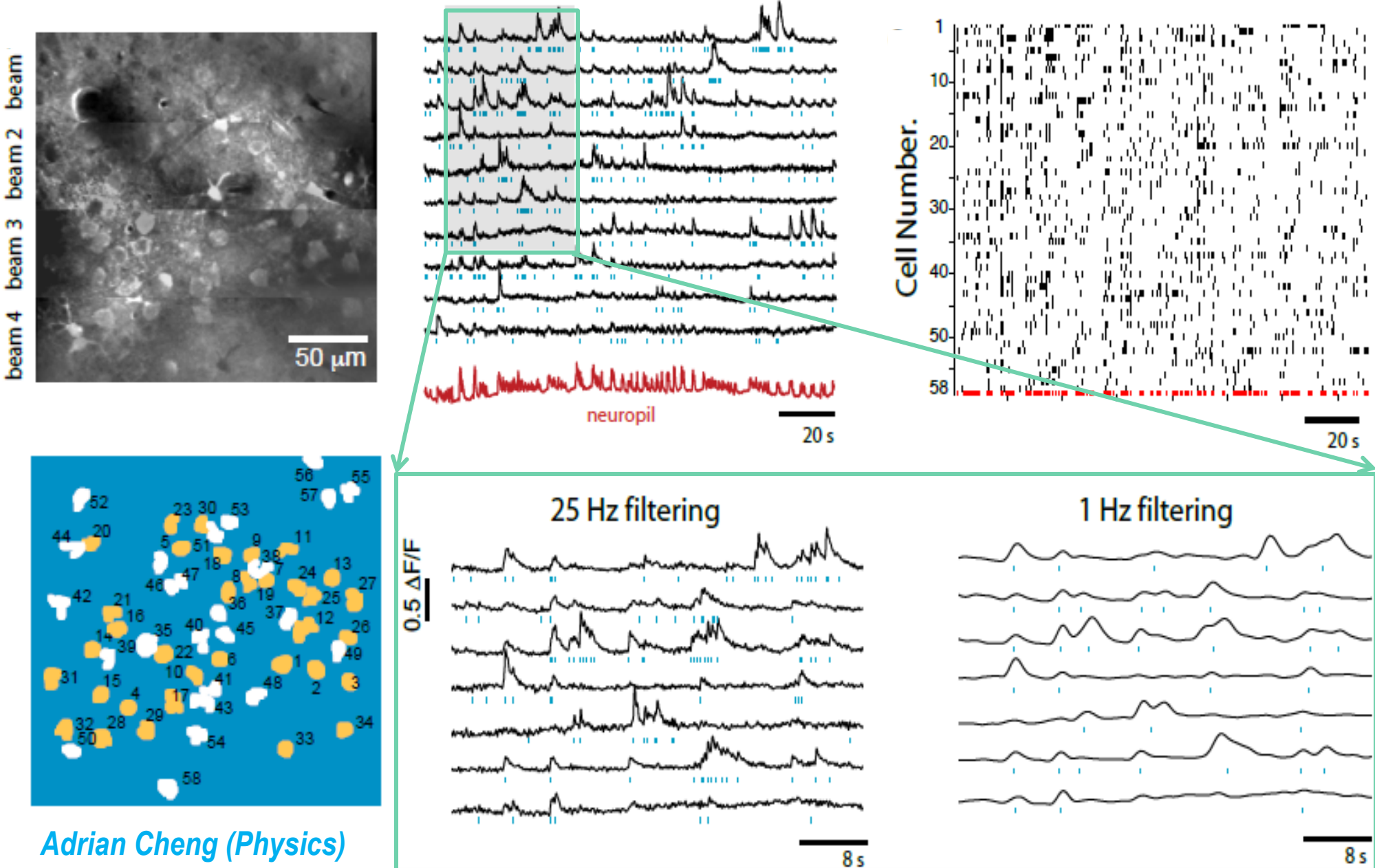

Adrian Cheng (Physics)

Fluo-4 AM labeled astrocytes are colabeled with sulforhodamine 101 to eliminate background (yellow)

Glass microelectrode for dye injection and electrophysiology

- cell-attached voltage follower
- whole-cell voltage/current clamp
- $10^{15} \Omega$ input impedance, $< 150 \text{ fA}$ input current bias

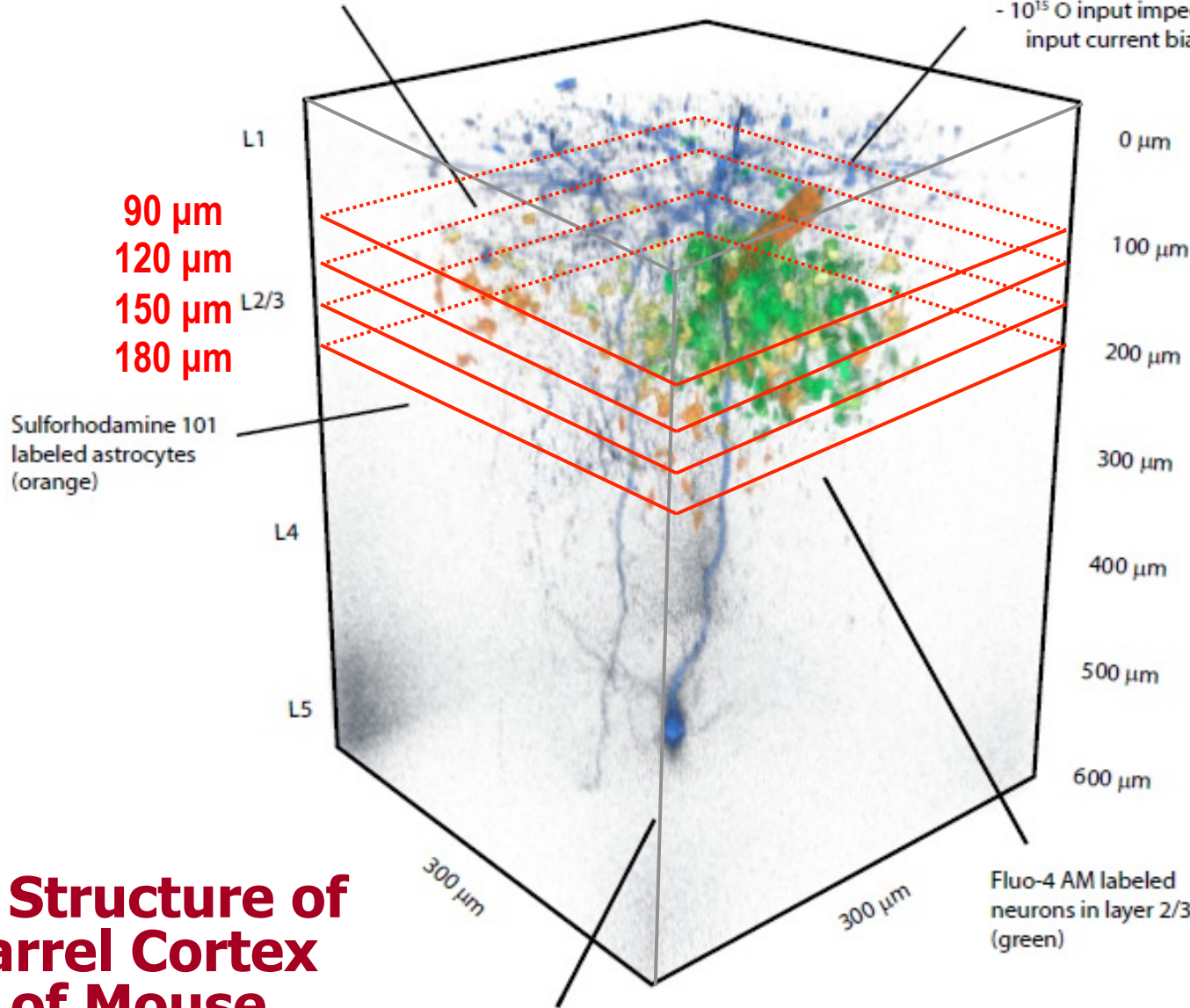

3D Structure of Barrel Cortex of Mouse

Adrian Cheng
(Physics)

Tiago Goncalves,
Peyman Golshani,
Carlos Portera-Cailliau
(Neurology)

Layer 5 pyramidal neuron soma and apical dendrite from a transgenic animal demonstrates imaging depth (blue)

Katsushi Arisaka, UCLA

Simultaneous in vivo calcium imaging in 4 axial planes

Barrel
Cortex
Layer 2/3

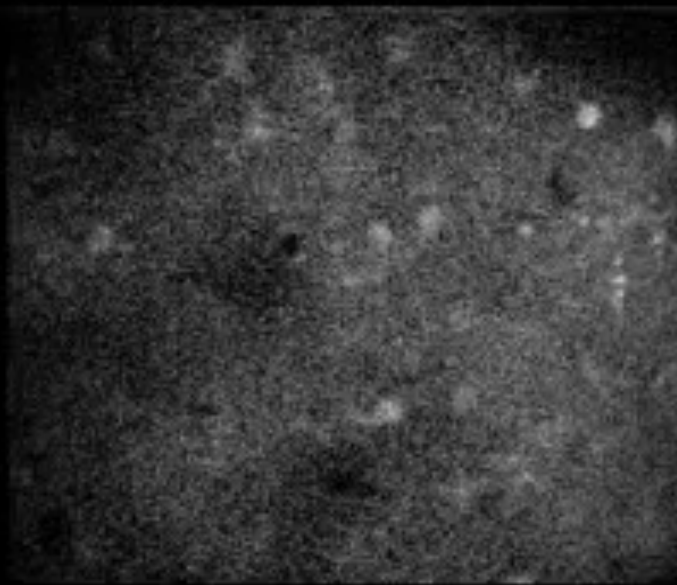

Beam 1 90 μm

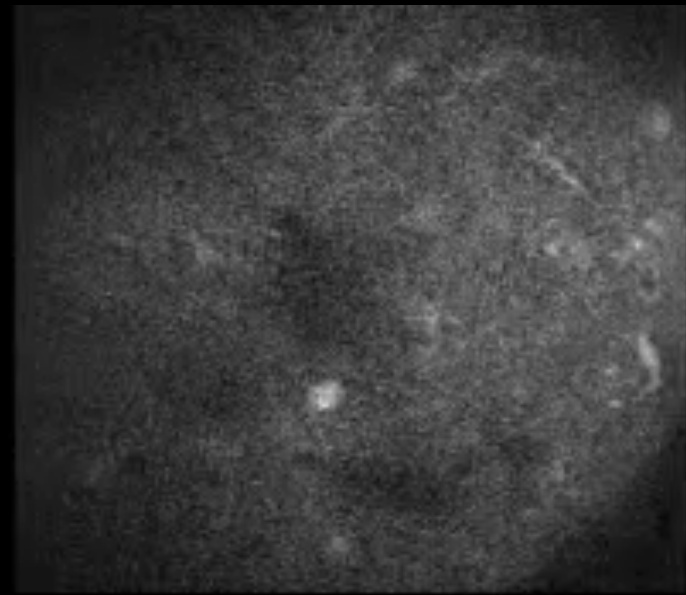

Beam 2 120 μm

60 fps

(x3 faster
than real)



Beam 3 150 μm

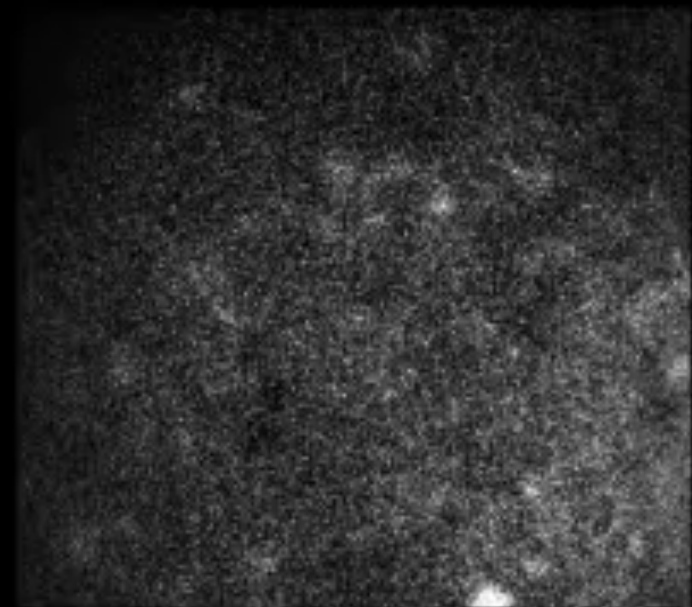

Beam 4 180 μm

Simultaneous in vivo calcium imaging of neuronal activity in 4 axial planes with STEM

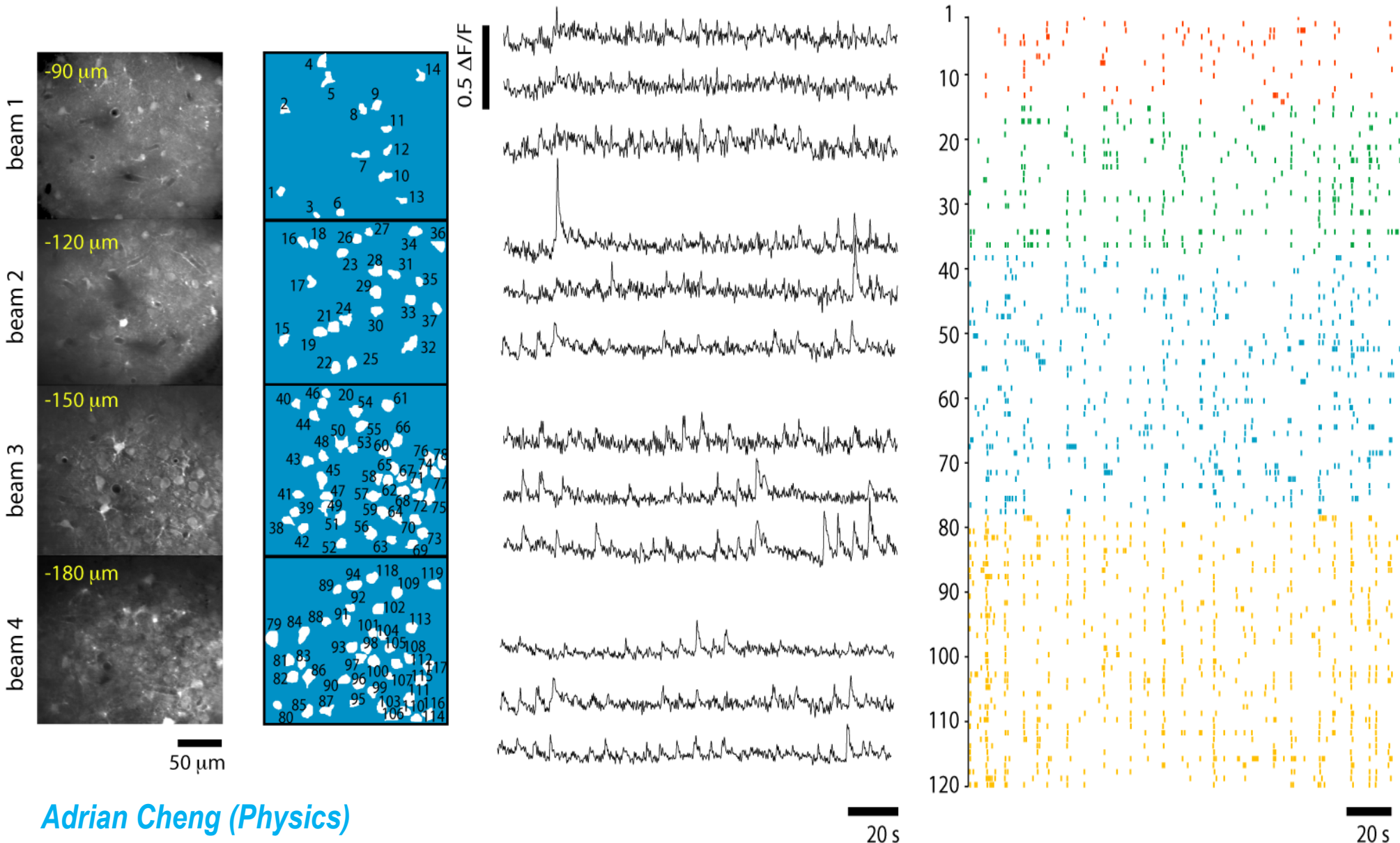

Adrian Cheng (Physics)

Future Directions

How can we recognize and memorize the space?

Mayank Mehta (Physics, Neurology)



Tetrodes

Activity of (excitatory) pyramidal neurons in CA depends on rat's position: place cells

Mayank Mehta (Physics, Neurology)

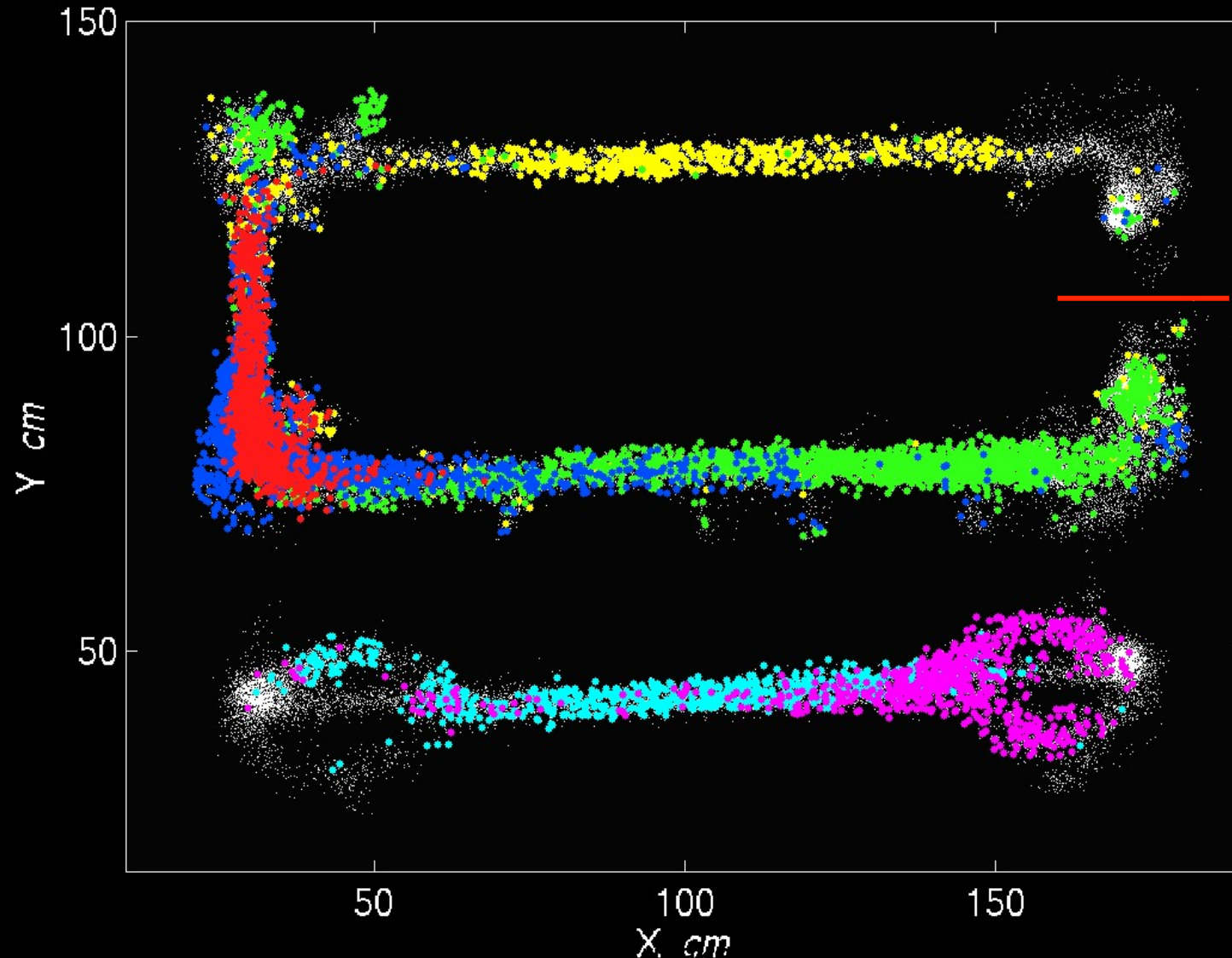

Hippocampus has a cognitive map of space

A mouse running in a Maze of Virtual Reality



Virtual Reality Experiment on Awake Rats

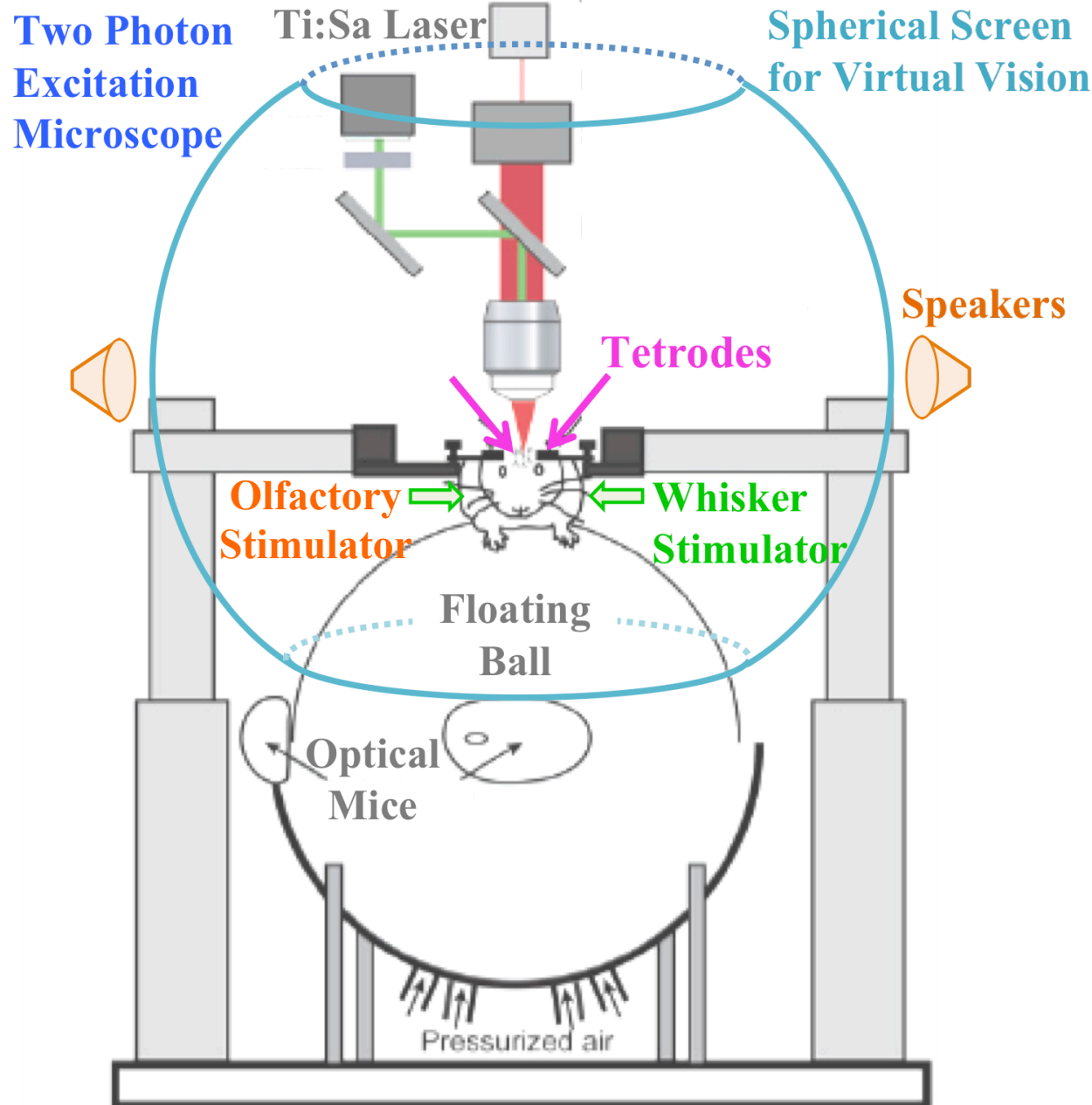

*Daniel Aharoni
Bernard Willers
Mayank Mehta
(Physics)*

Optogenetic Excitation of Neurons

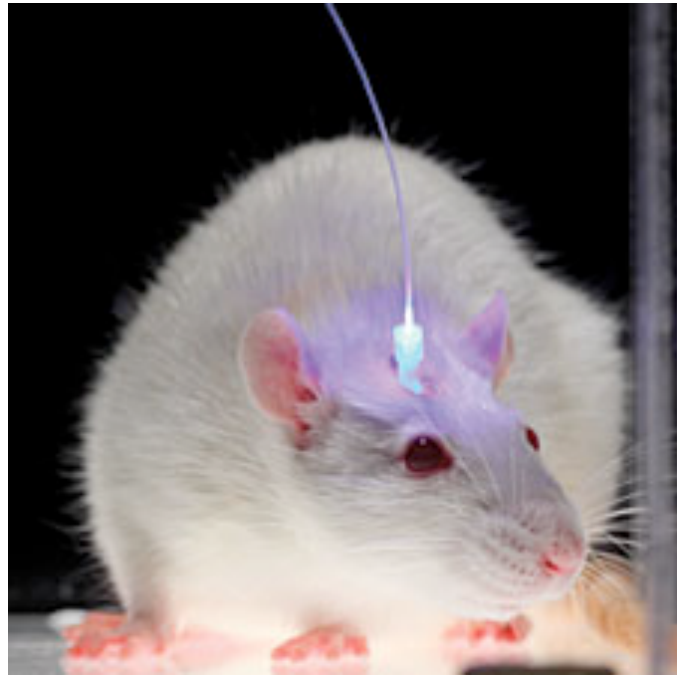

Karl Deisseroth (Stanford)

Excitation by
Channelrhodopsin-2
(ChR2)

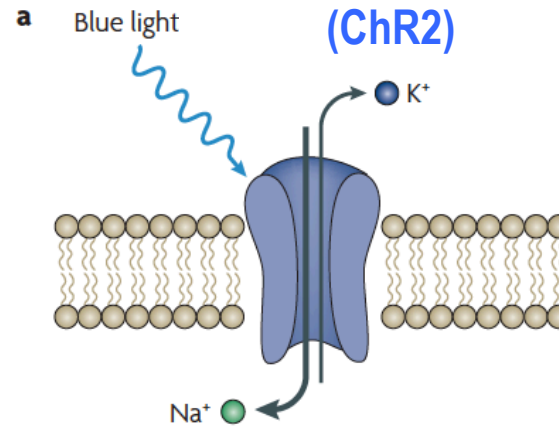

Inhibition by
Halorhodopsin
(NpHR)

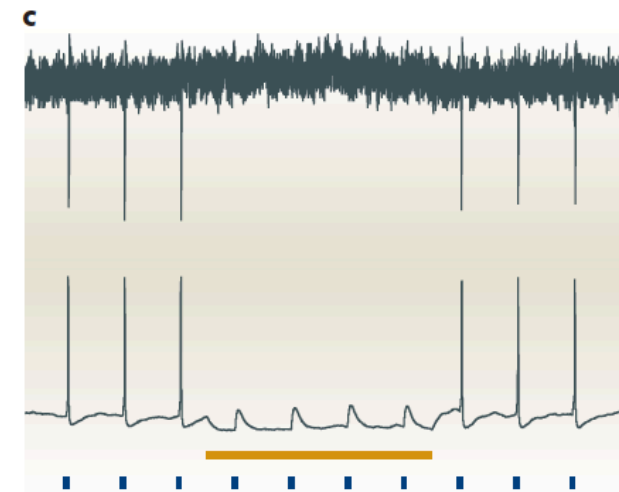
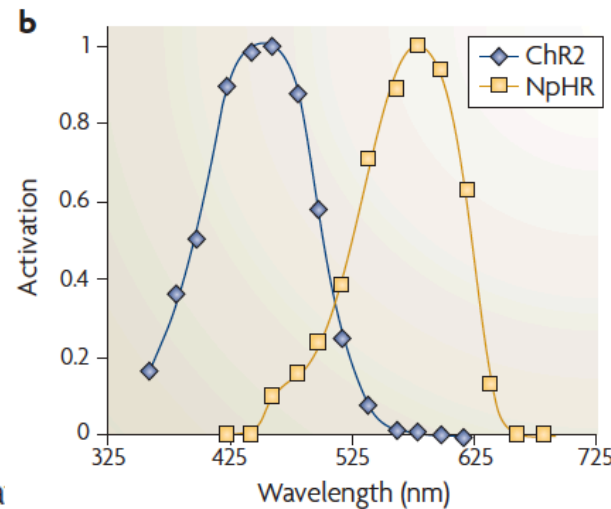
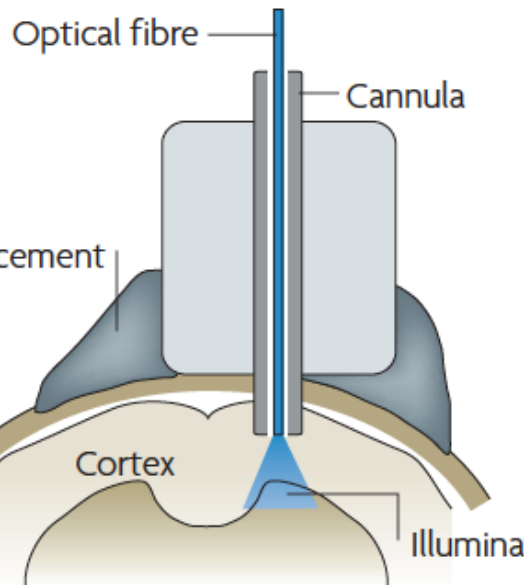
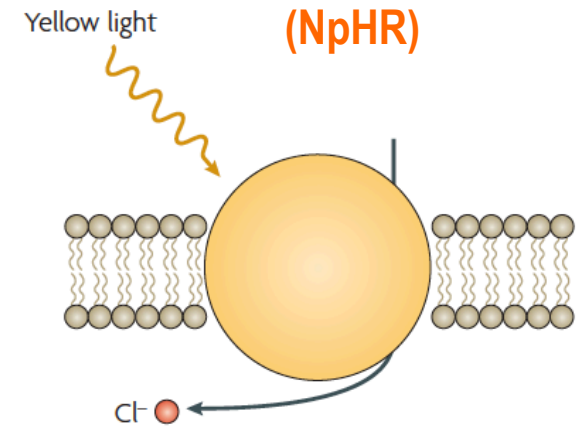

Outer world vs. Inner world

- Outer world : Five senses → Manipulate by Virtual Reality
 - Vision
 - Sound
 - Touch
 - Smell
 - Taste
- Inner world → Manipulate by Photo Excitation of single neurons
 - Neural network in brain
- Establish direct link between Inner world & Outer world
 - Control outer world – Virtual reality
 - Control inner world – Neural reality

Ca²⁺ Signal in cultivated Rat's Brain by Confocal Microscope

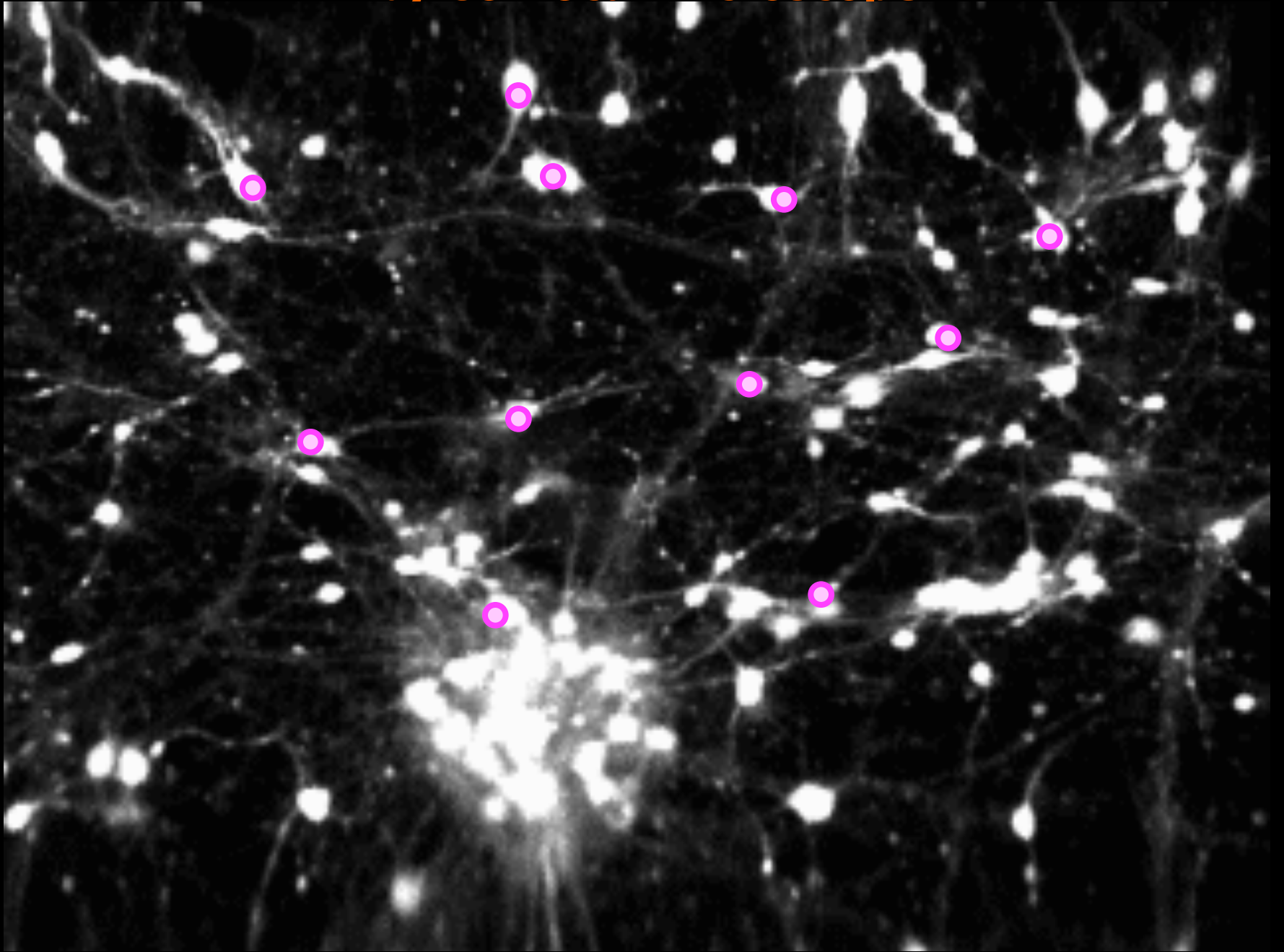

LCOS (Liquid Crystal on Silicon) for SLM (Spatial Light Modulator)

Hamamatsu



X10468 Head and Controller

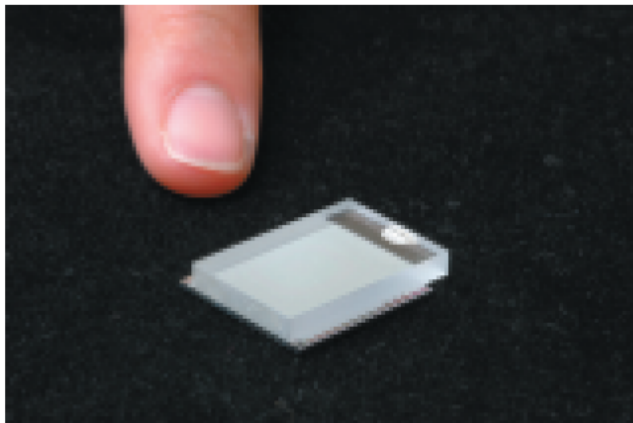

LCOS chip inside the Head

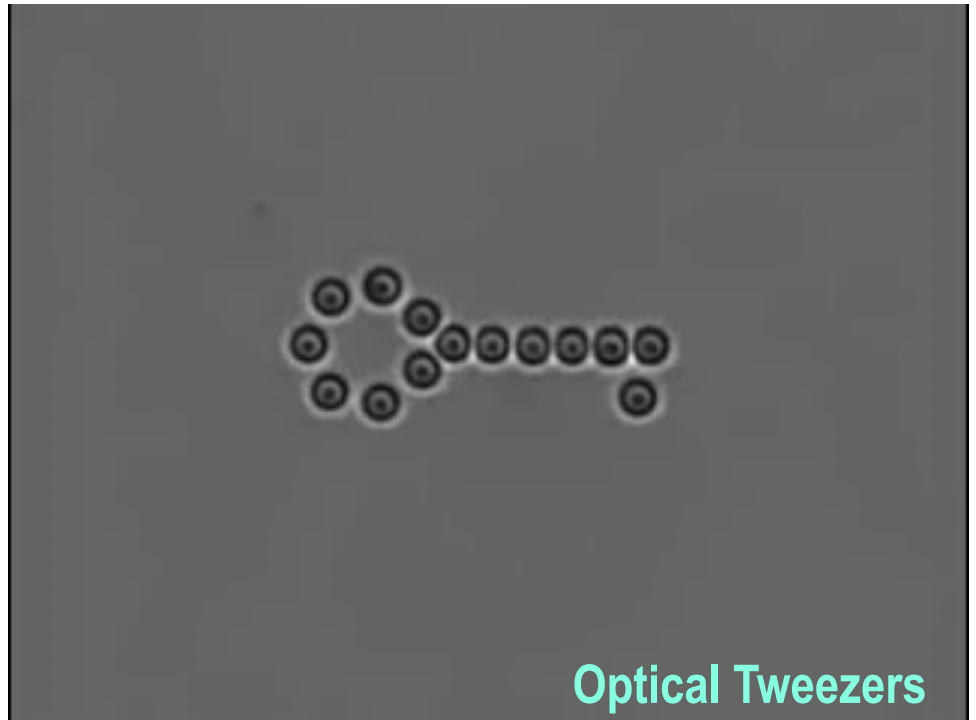
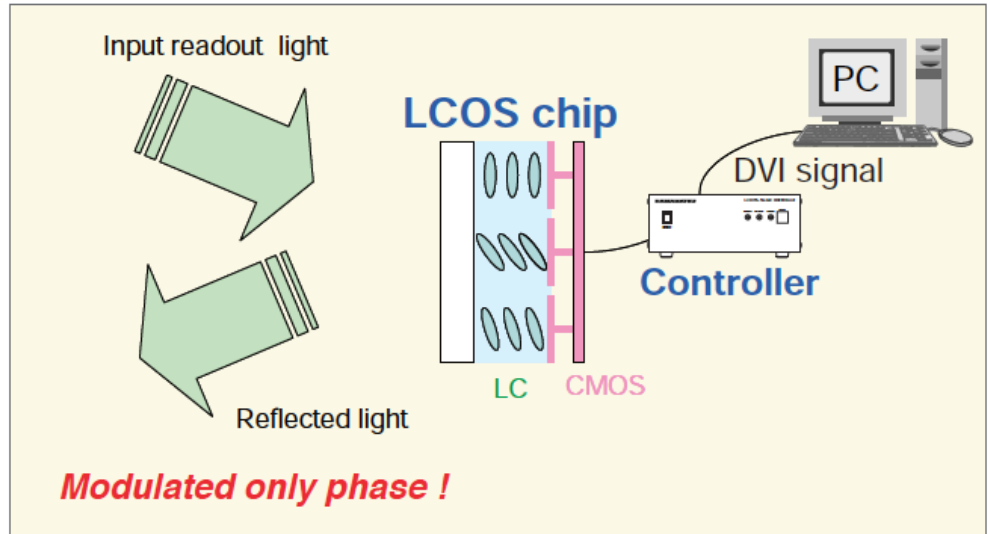

Voltage Sensing Dye by FRET

Tom Otis (Neurobiology)

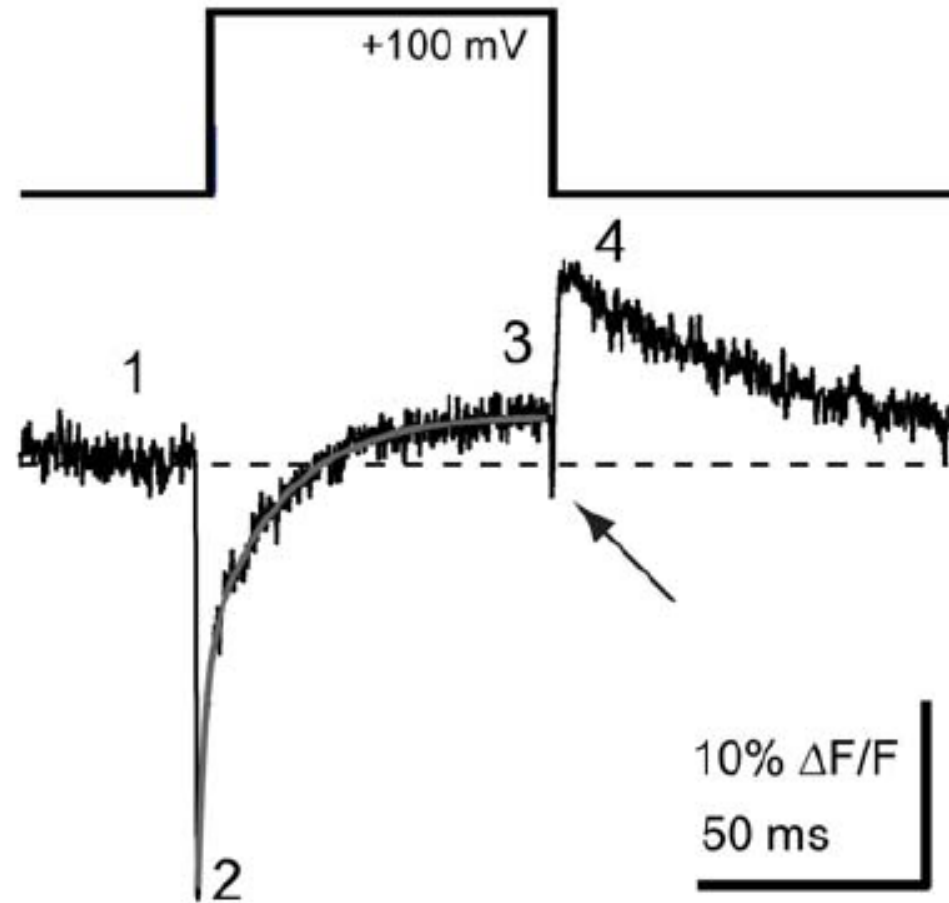
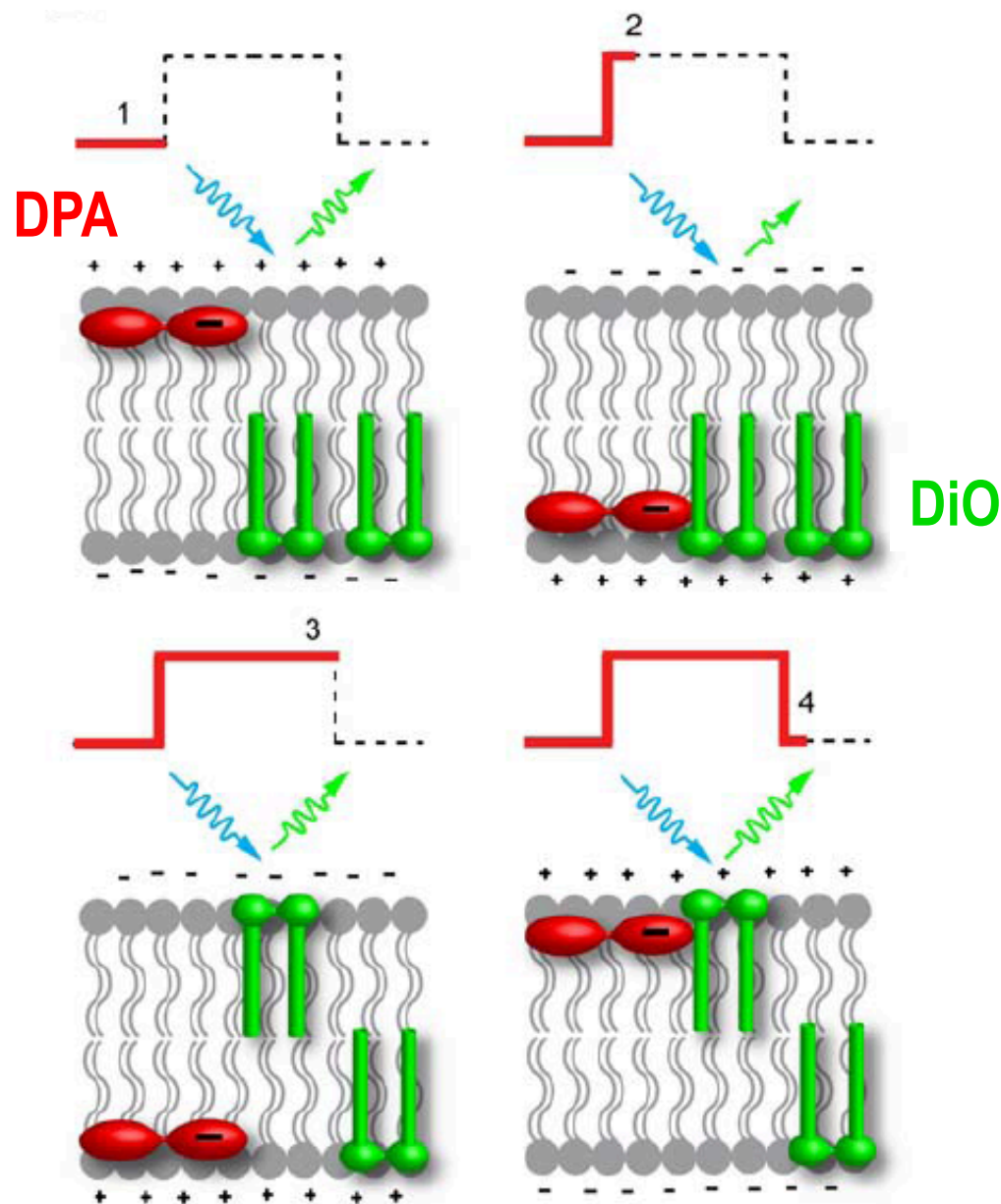

Voltage Sensing Dye

Tom Otis (Neurobiology)

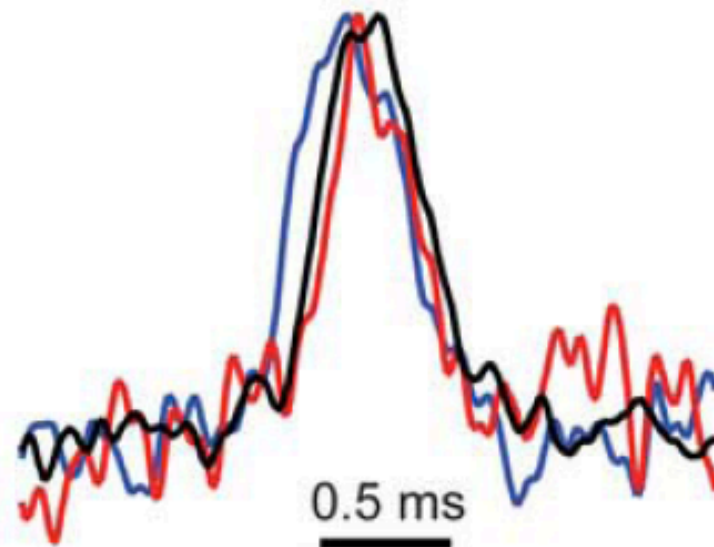
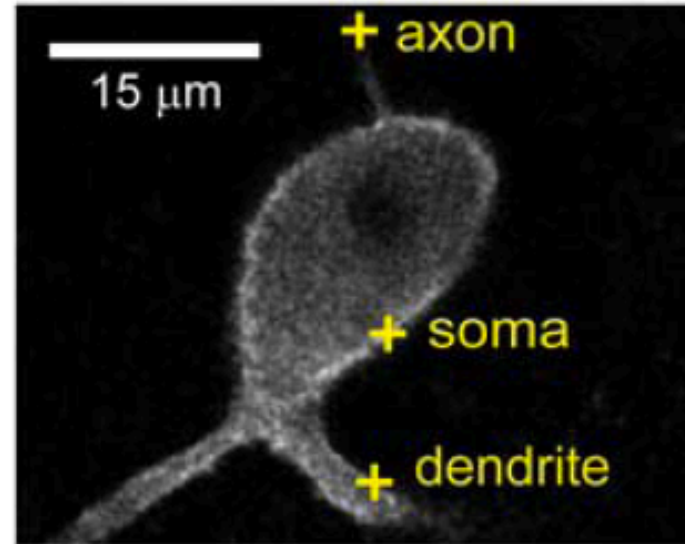
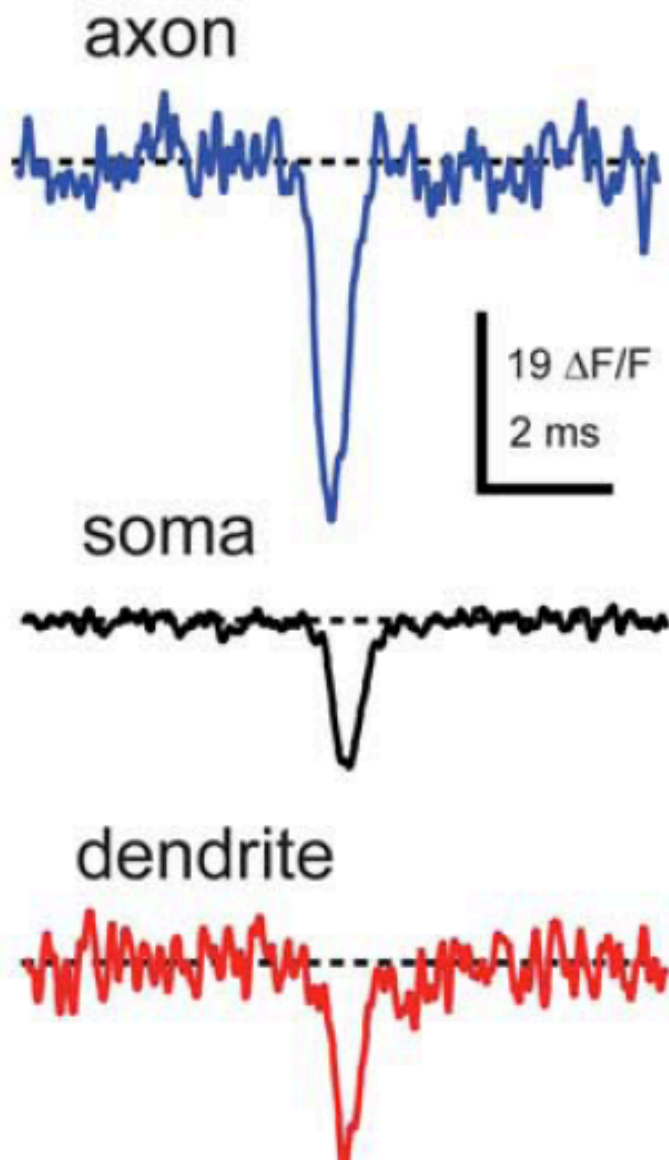

Ca²⁺ Signal in cultivated Rat's Brain by Confocal Microscope

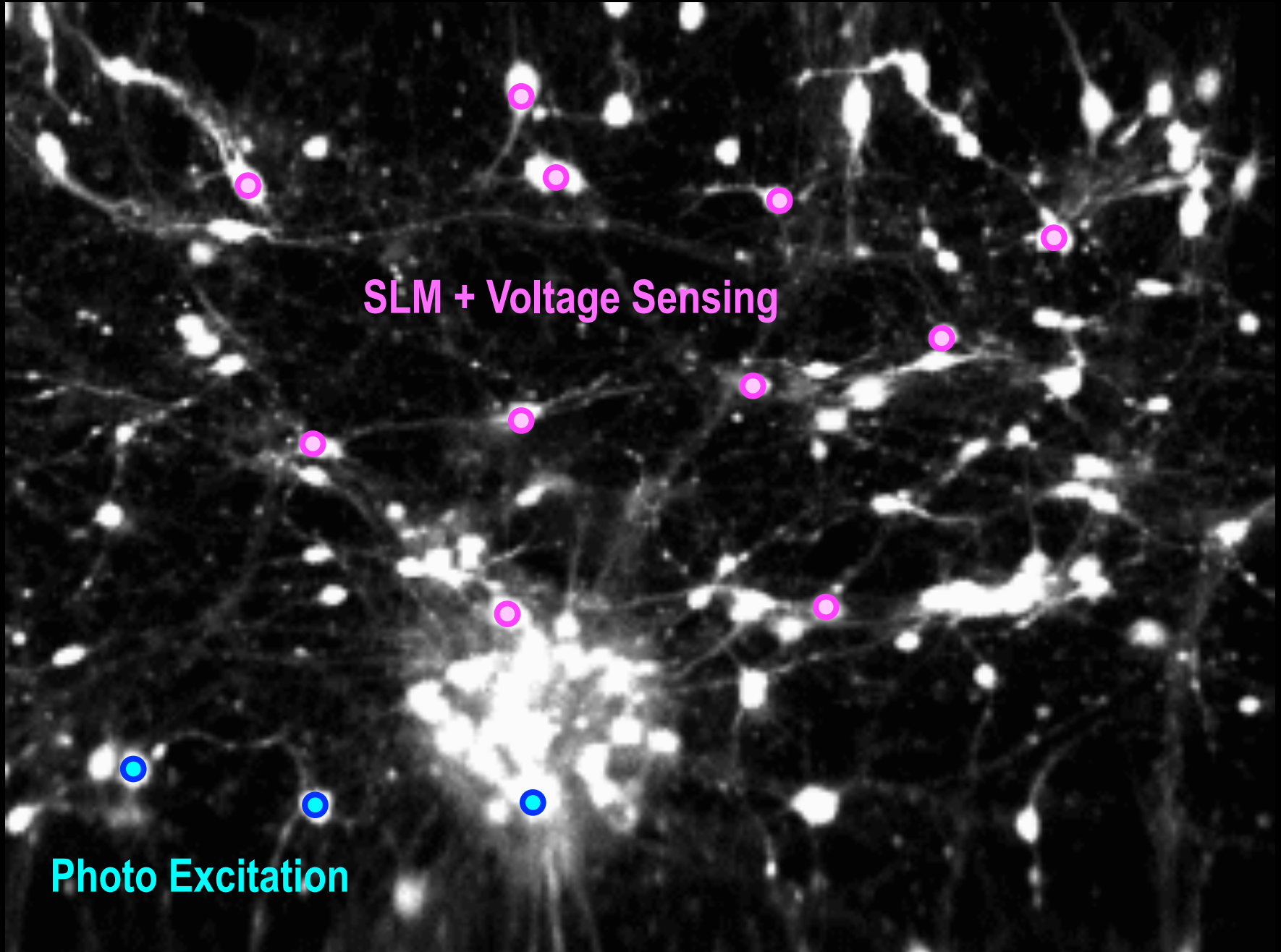

Summary

The Four Largest Mysteries in Nature

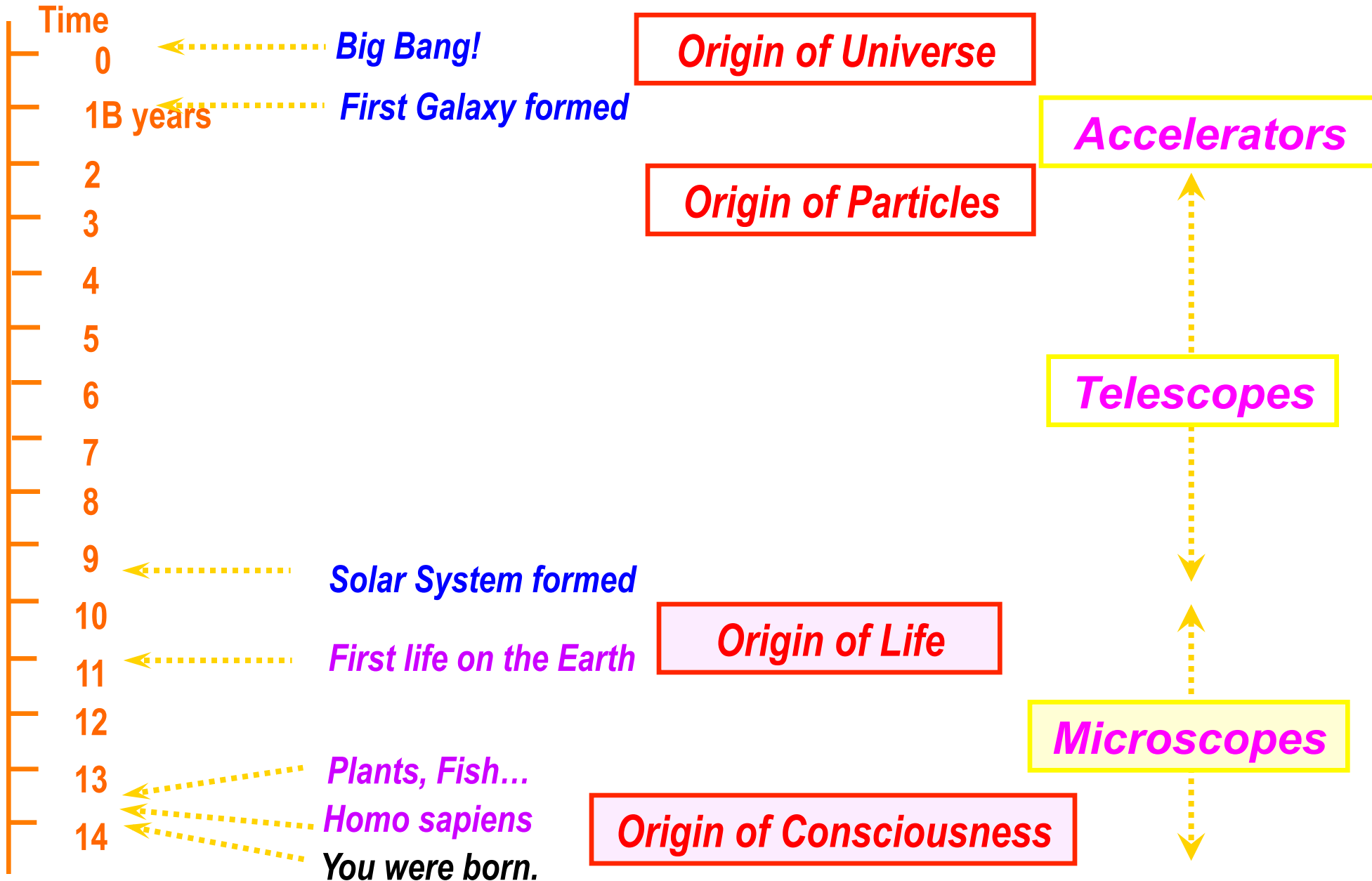

Four Major Science

Origin of Particles
Particle Physics

Origin of Universe
Cosmology

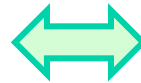

Origin of Life
Molecular Biology

Origin of Consciousness
Neurophysics

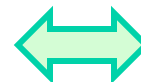

Future of Ultra High-speed Bio Imaging

➤ Origin of Life:

- Networks of molecules in/on a cell
- Competition against Brownian : 10 – 100 nm / 1 msec

➤ Origin of Consciousness:

- Neural networks
- Action potentials: 1 msec



➤ > 1,000 frame/sec with nano second time stamp.

- Gated Image Intensified CMOS
- Super-PIAS (GHz Photon-counting Imager)
- 6D Imaging by Streak-CMOS Camera

Concluding Remarks

- **“Life” is a complex system in 4 dimensional space-time.**
 - Emergent property
 - Strongly interacting
 - **Countless “spontaneous symmetry breakings” during the evolutionary and developing process of life**
 - **Fully controlled experiments by “Virtual Reality” under way.**
 - Outer world (environment) vs. Inner world (brain)
- 
- **“Ultra high-speed imaging” may reveal the fundamental principle of the complex life like ours.**
 - How can life overcome thermal fluctuation?
 - Networks in a cell and between cells (neurons)

and thanks to wonderful collaborators!

Scientific Objectives	Department	Prime PI	Other Senior Person	Grad Students	Sample	High-speed Microscopes	Funding	Activities
Neurophysics (Virtual Reality)	Physics & Astronomy, Neurology	Mayank Mehta		Daniel Aharoni, Bernard Willers	Rat	2PE, Tetrode	Keck Foundation pending	2009 - Now
Hair cell motion	Physics & Astronomy	Dolores Bozovic		Lea Fredrickson	Frog	CMOS	NSF MRI	2007 - Now
Neutral Networks	Physics & Astronomy	Katsushi Arisaka	Luis Beltran-Parrazal	Adrian Cheng	Zebrafish	2PE, Conforcal	NSF MRI	2008 - 2009
Single Molecule	Chemistry	Shimon Weiss	Xavier Michalet, Ryan Colyer	Daniel Aharoni	Cells	64ch FCS, ALEX	NIH R01	2006 - Now
TfR tracking on Cancer cells	Oncology, Physics & Astronomy	Manuel Penichet, John Miao	Gustavo Helguera, Jose Rodriguez		Cells	CMOS, ICMOS	(NSF MRI shared)	2007 - Now
Neural networks for breathing	Neurobiology	Jack Feldman	Consuelo Morgado	Adrian Cheng	Rat	ICMOS, Confocal	(NSF MRI shared)	2007 - 2008
Neural networks (Voltage sensing dyes)	Neurobiology	Tom Otis		Bernard Willers	Sliced Brain	ICMOS, 2PE	NIH Rec. Act	2009 - Now
Development of neural networks	Neurology	Carlos Portera-Cailliau	Peyman Golshani, Tiago Goncalves	Adrian Cheng	Mouse	2PE	NIH Rec. Act pending	2008 - Now
High-speed Imaging Flow Cytometer	Electrical Engineering	Bahram Jalali			Cells	ICMOS	NIH R21 pending	2009 - Now
Core facility of High-speed Bio-imaging	CNSI	Shimon Weiss	Laurent Bentolila		Anything	CMOS, ICMOS, EMCCD	CNSI internal	2008 - Now
Multi-channel HAPD, LCOS	Hamamatsu	Suyama Motohiro				2PE, EMCCD	EMCCD, LCOS donated	2006 - Now
CMOS Camera	Photron	Tak Takimizu				CMOS, ICMOS	3 CMOS donated	2007 - Now
High-speed Microscope	Leica	Thomas Zhapf				CMOS, ICMOS, 2PE	Microscope discounted	2008 - Now

Energy Resolution

Energy Resolution (σ/E)

➤ In ideal case:

$$\frac{\sigma}{E} = \frac{\sqrt{N_\gamma}}{N_\gamma} = \sqrt{\frac{1}{N_\gamma}}$$

➤ In reality:

$$\frac{\sigma}{E} = \sqrt{\frac{ENF}{N_\gamma \cdot QE \cdot CE} + \left(\frac{ENC}{N_\gamma \cdot QE \cdot CE \cdot G} \right)^2}$$

- N_γ
- QE
- CE
- ENF
- ENC
- G

Number of incident photons

Quantum Efficiency

Collection Efficiency:

Excess Noise Factor (from Dynodes)

Equivalent Noise Charge (Readout Noise)

Gain

Excess Noise Factor (ENF)

➤ Definition:

$$ENF \equiv \frac{\sigma_{Output}^2}{\sigma_{Input}^2}$$

➤ In case of PMT:

$$ENF = 1 + \frac{1}{\delta_1} + \frac{1}{\delta_1 \cdot \delta_2} + \cdots + \frac{1}{\delta_1 \cdot \delta_2 \cdots \delta_n}$$

Quantum Efficiency

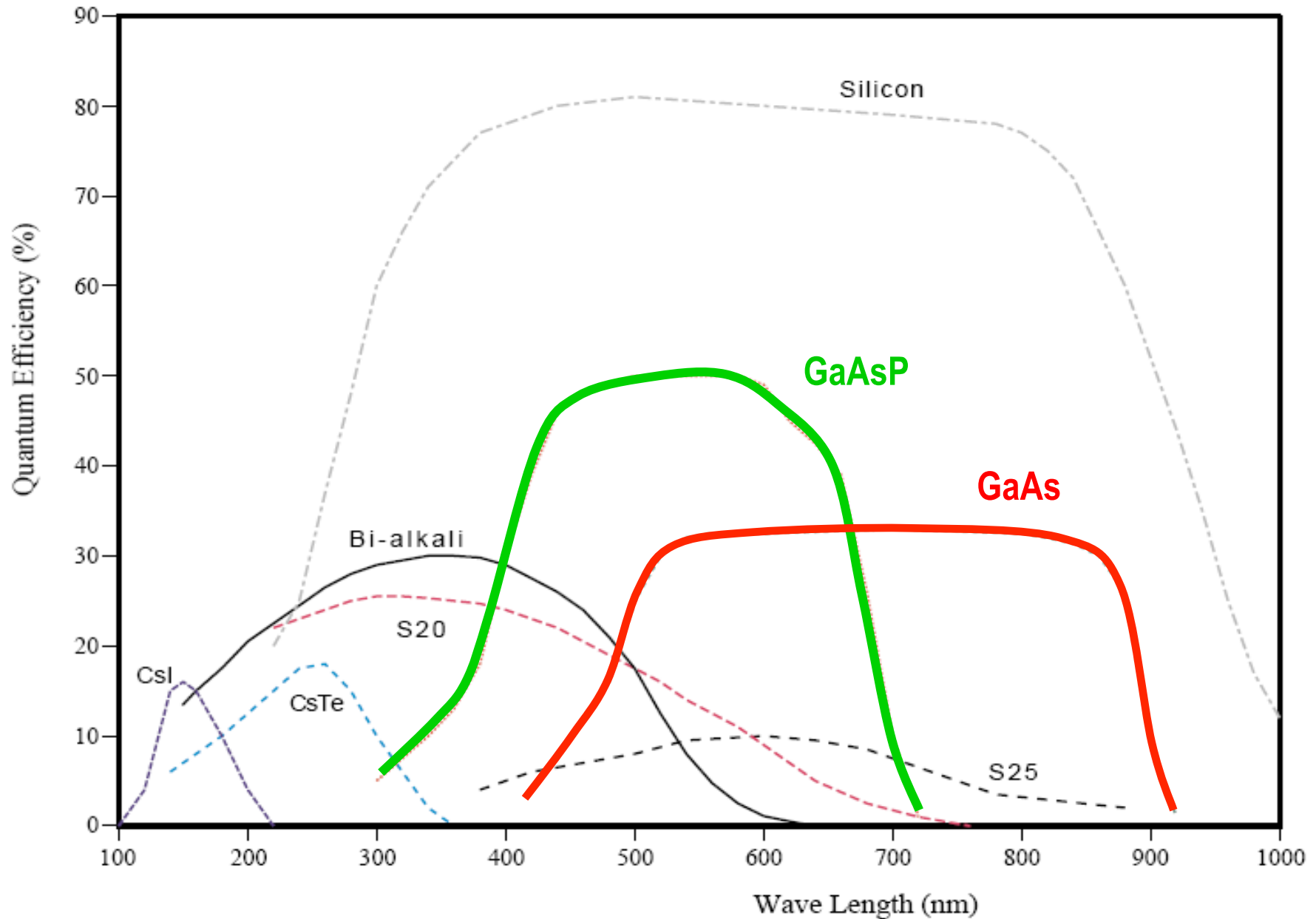

Energy Resolution of HPD

- HPD can count 1, 2, 3... PE separately.
 - ENF=1.0

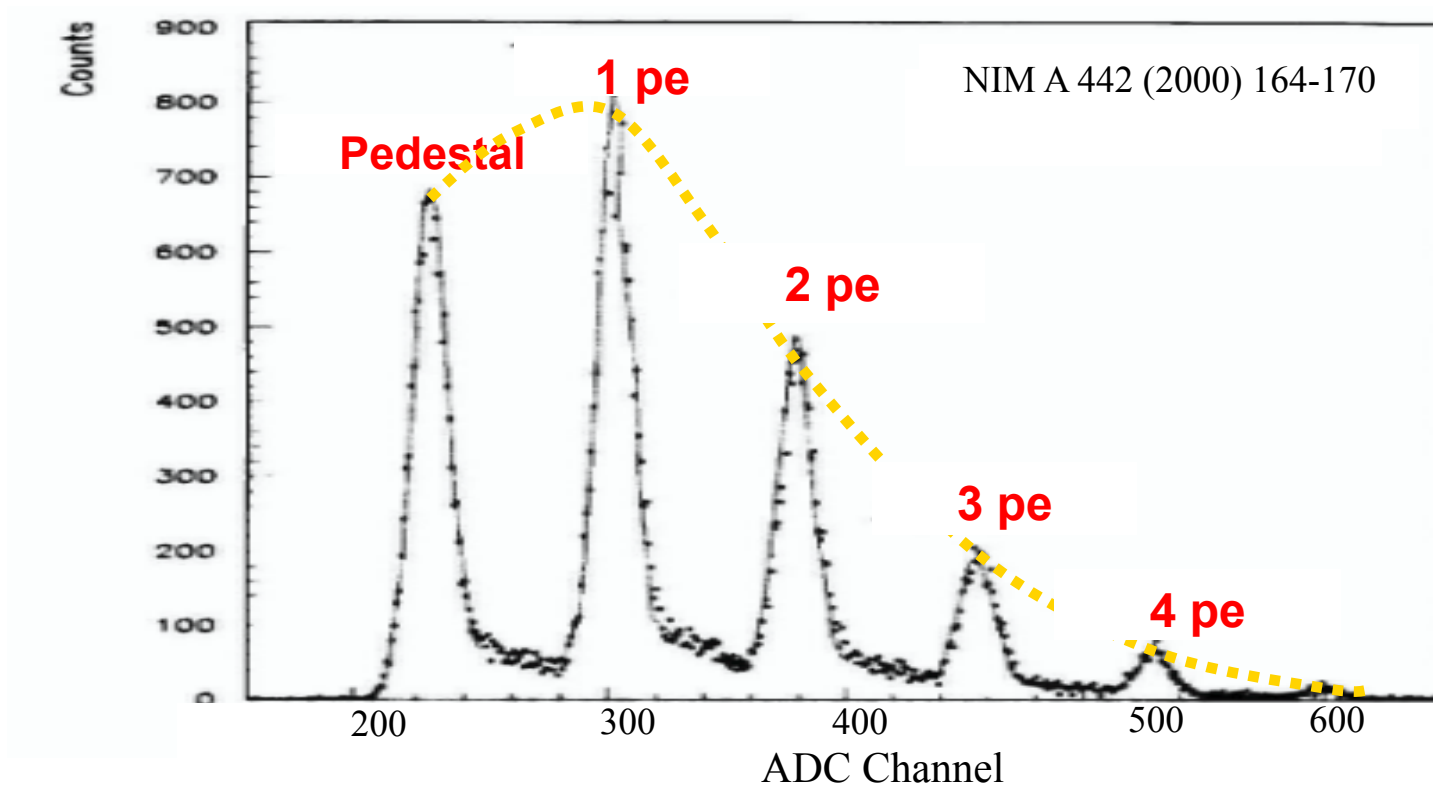

- But it is still suffering from poor QE.
 - We can never beat the Poisson statistics !

Summary Table of Energy Resolution

	QE	CE	δ_i	ENF	G	ENC	σ/E
Ideal	1.0	1.0	1000	1.0	10^6	0	$\sqrt{1/N}$
PMT	0.5	0.8	10	1.3	10^6	200	$\sqrt{3.6/N}$
PD	0.8	1.0	-	1.0	1	200	$\sqrt{1.3/N+(300/N)^2}$
APD	0.8	1.0	2	2.0	50	200	$\sqrt{2.5/N+(5/N)^2}$
HPD	0.5	0.9	1000	1.0	10^3	200	$\sqrt{2.2/N+(1.1/N)^2}$
HAPD	0.5	0.9	1000	1.0	10^5	200	$\sqrt{2.2/N}$
CCD	0.8	1.0	-	1.0	1	50	$\sqrt{1.3/N+(60/N)^2}$
ICCD / ICMOS	0.8	0.7	-	2.0	10^4	50	$\sqrt{5.7/N}$
EMCCD	0.8	1.0	2	2.0	10^3	50	$\sqrt{2.5/N}$
EBCCD / EBCMOS	0.5	0.85	1000	1.0	10^3	50	$\sqrt{2.35/N}$

Energy Resolution

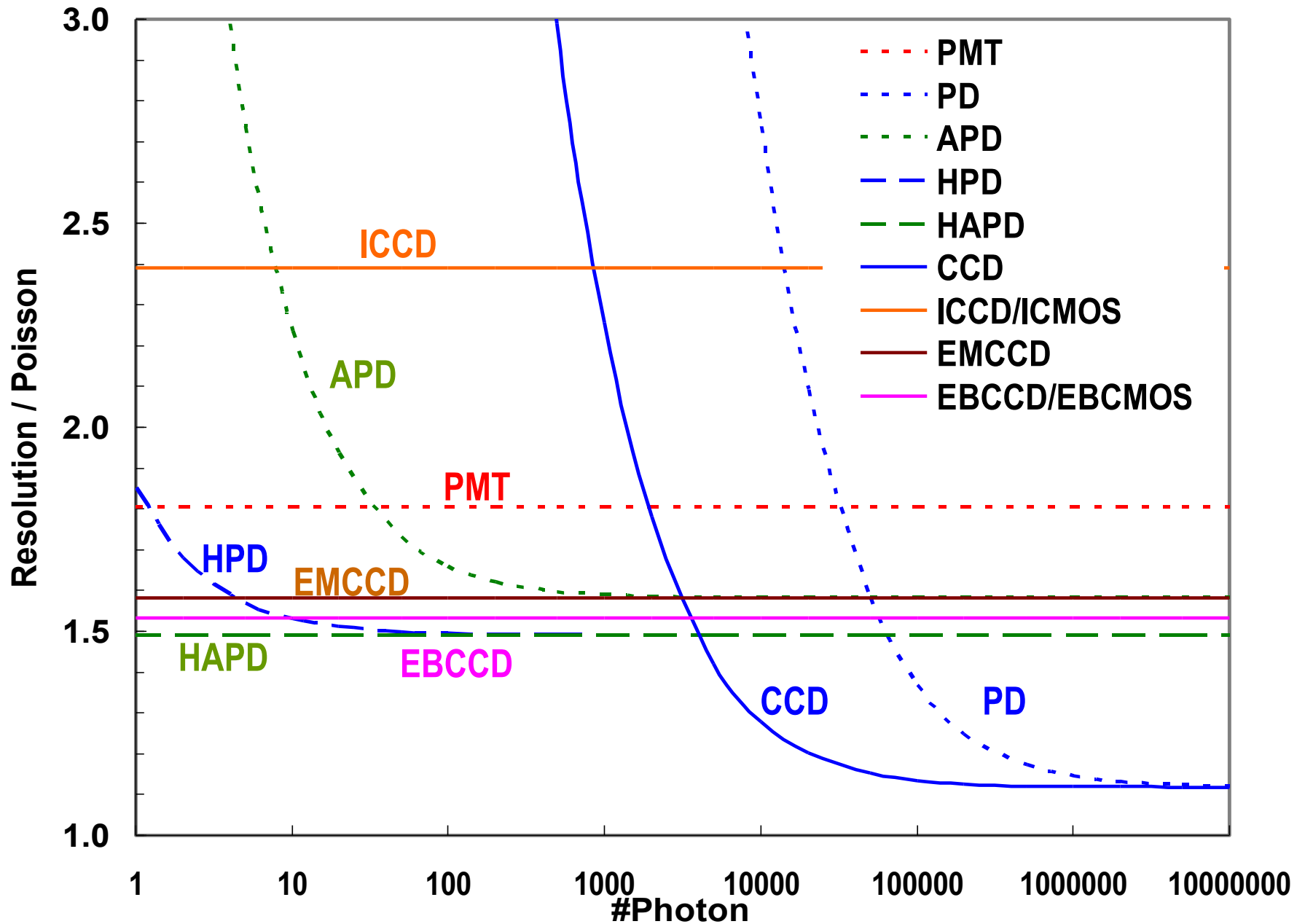



sCMOS

Scientific CMOS Technology

A High-Performance Imaging Breakthrough

sCMOS - 1.5 e⁻ noise

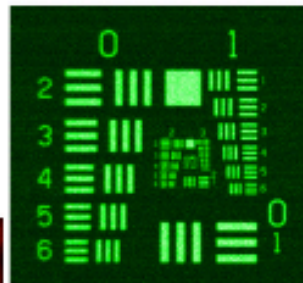

Interline CCD - 5 e⁻ noise

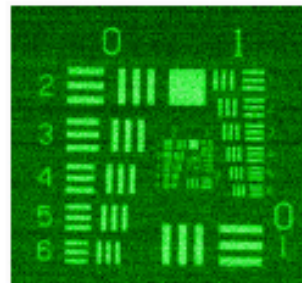

5.5 Megapixel sCMOS
100 frames/sec

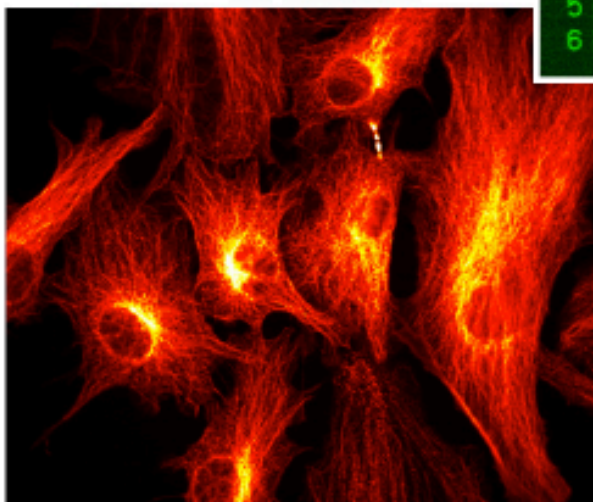

1.3 Megapixel Interline
11 frames/sec

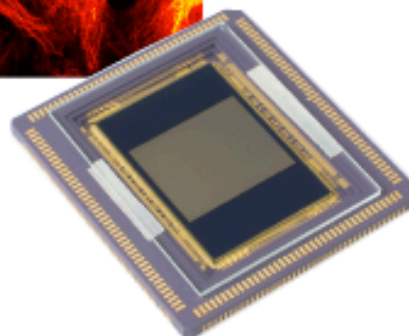
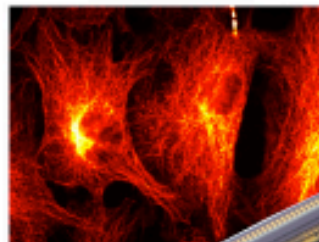



ORCA[®]-Flash2.8

DIGITAL CAMERA

Low noise

3 electrons
(r.m.s.)

High resolution

2.8 megapixel

High-speed readout

45 frames/second
(1920 × 1440)

Up to **1273** frames/second

High dynamic range

4500: 1

