

MAX + LZD = G3 Detector and Physics

Katsushi Arisaka

***University of California, Los Angeles
Department of Physics and Astronomy***

arisaka@physics.ucla.edu

Talk Outline

- **G3 Detector Concept**
 - Xenon 10 Ton + Argon 50 Ton (Fiducial)
- **Physics sensitivities**
 - Mass and Cross Section by Energy spectrum
 - WIMP Velocity by annual Modulation
- **Mechanical Design**
- **Status of QUPID**
 - New Photo cathode
 - Operation in Liquid Xenon

MAX – G3 Detector (from UCLA DM2010)

Xe

**20 ton
(10 ton)**

^{40}Ar

**70 ton
(50 ton)**

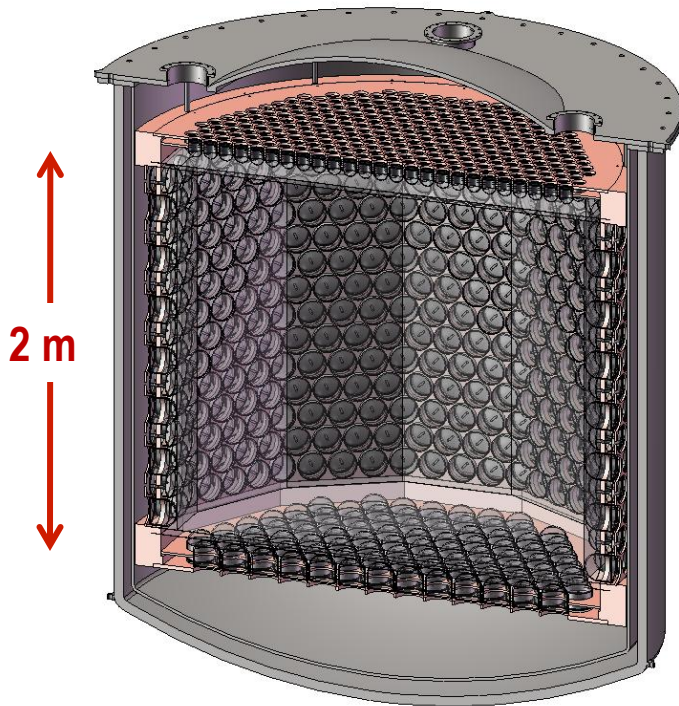

3" QUPID x 595 (Top)
6" QUPID x 825 (Side/Bottom)

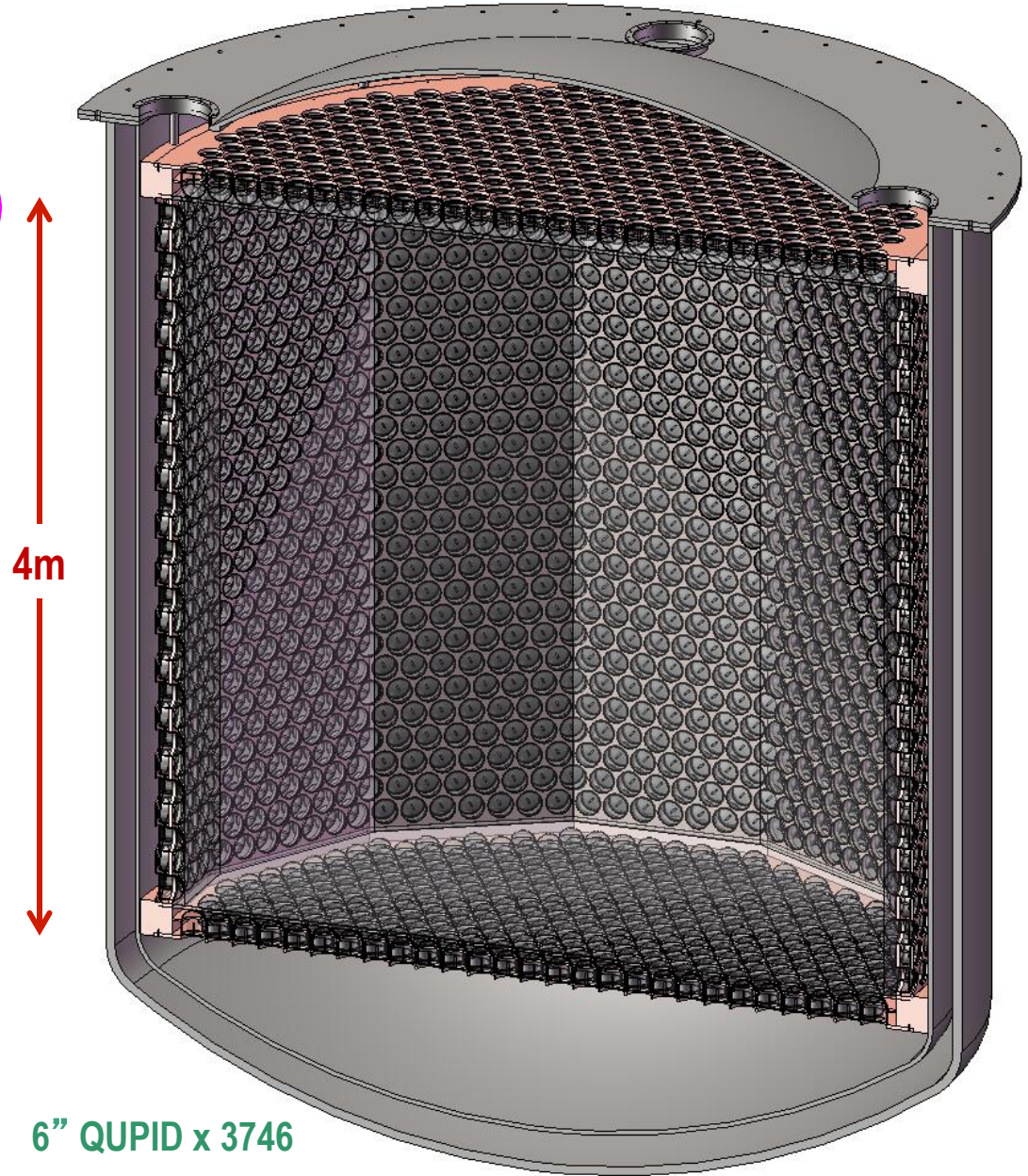

6" QUPID x 3746

MAX+LZD = G3 Detector (at DUSEL)

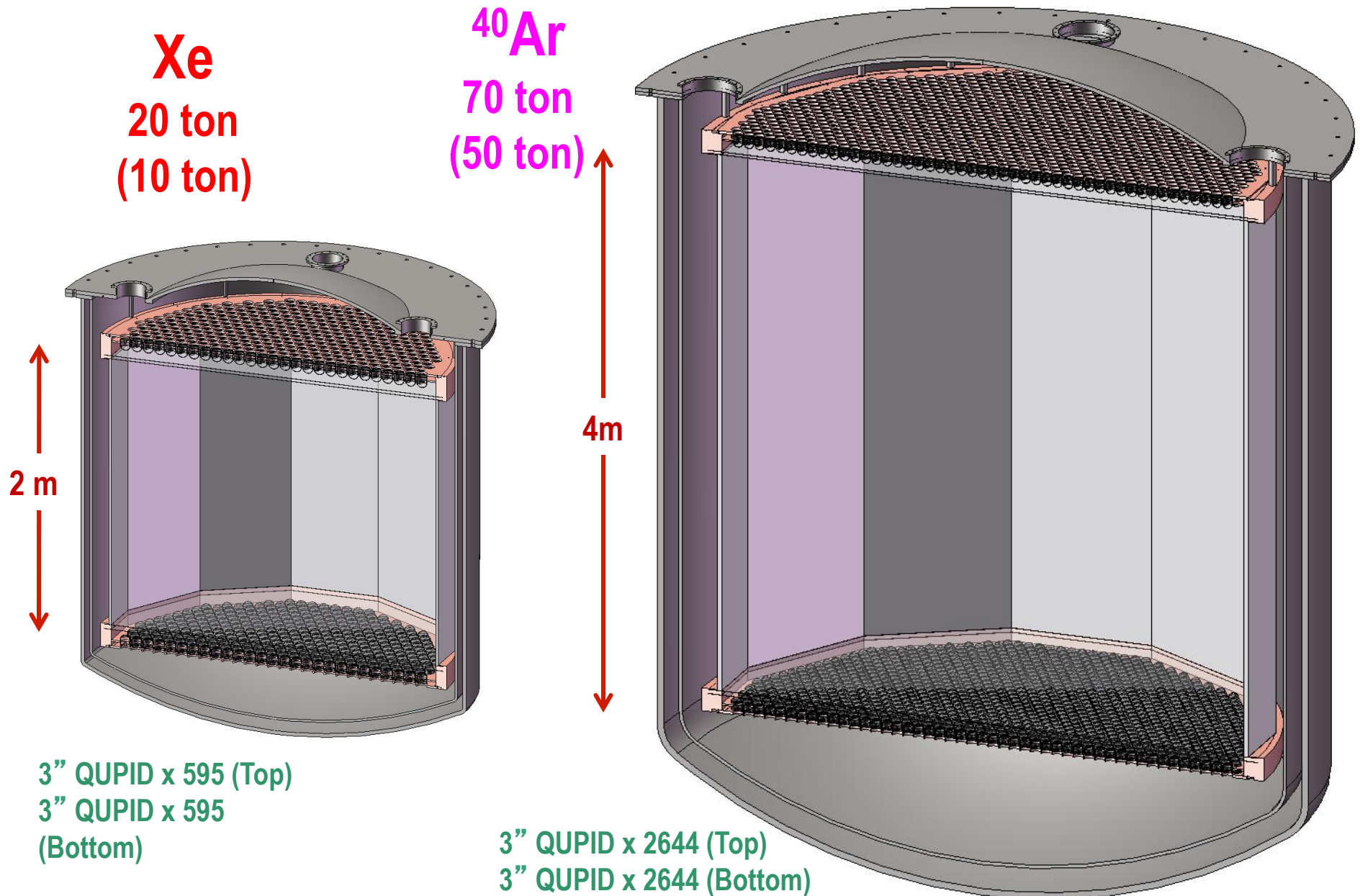

MAX+LZD = G3 Shielding Structure

Xe
20 ton
(10 ton)

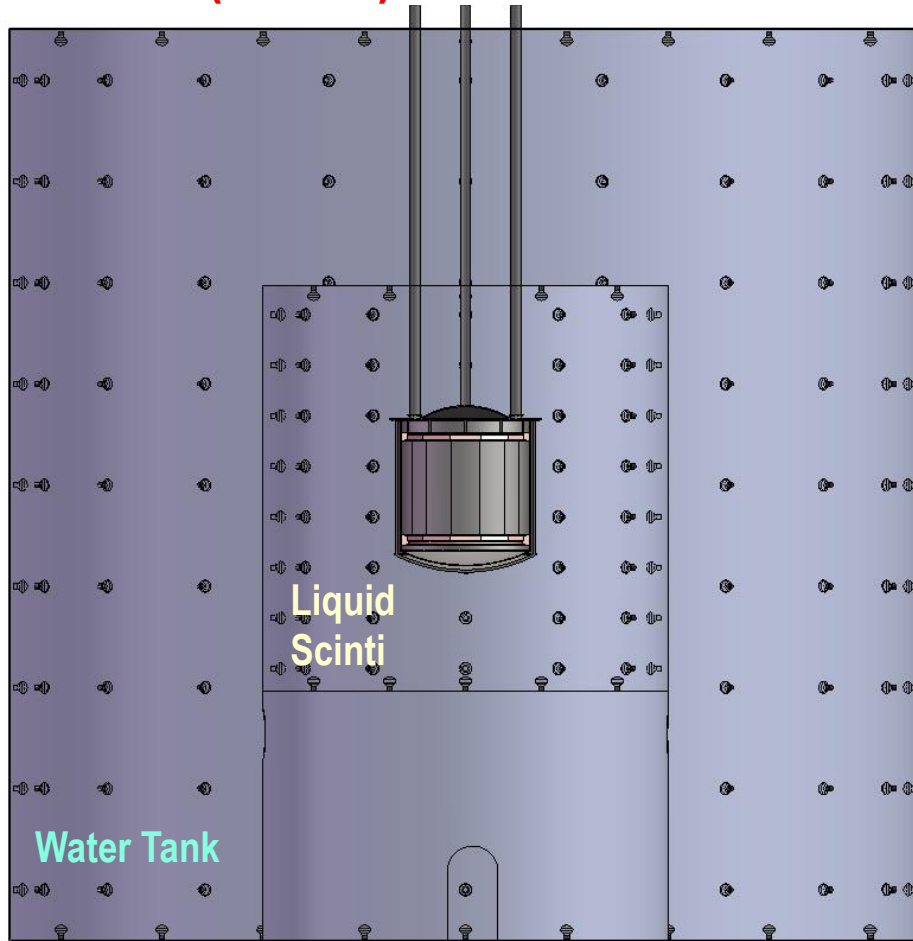

← 8 m →

^{40}Ar
70 ton
(50 ton)



← 18 m →

Physics Sensitivities

90% CL Limits of SI Cross Section

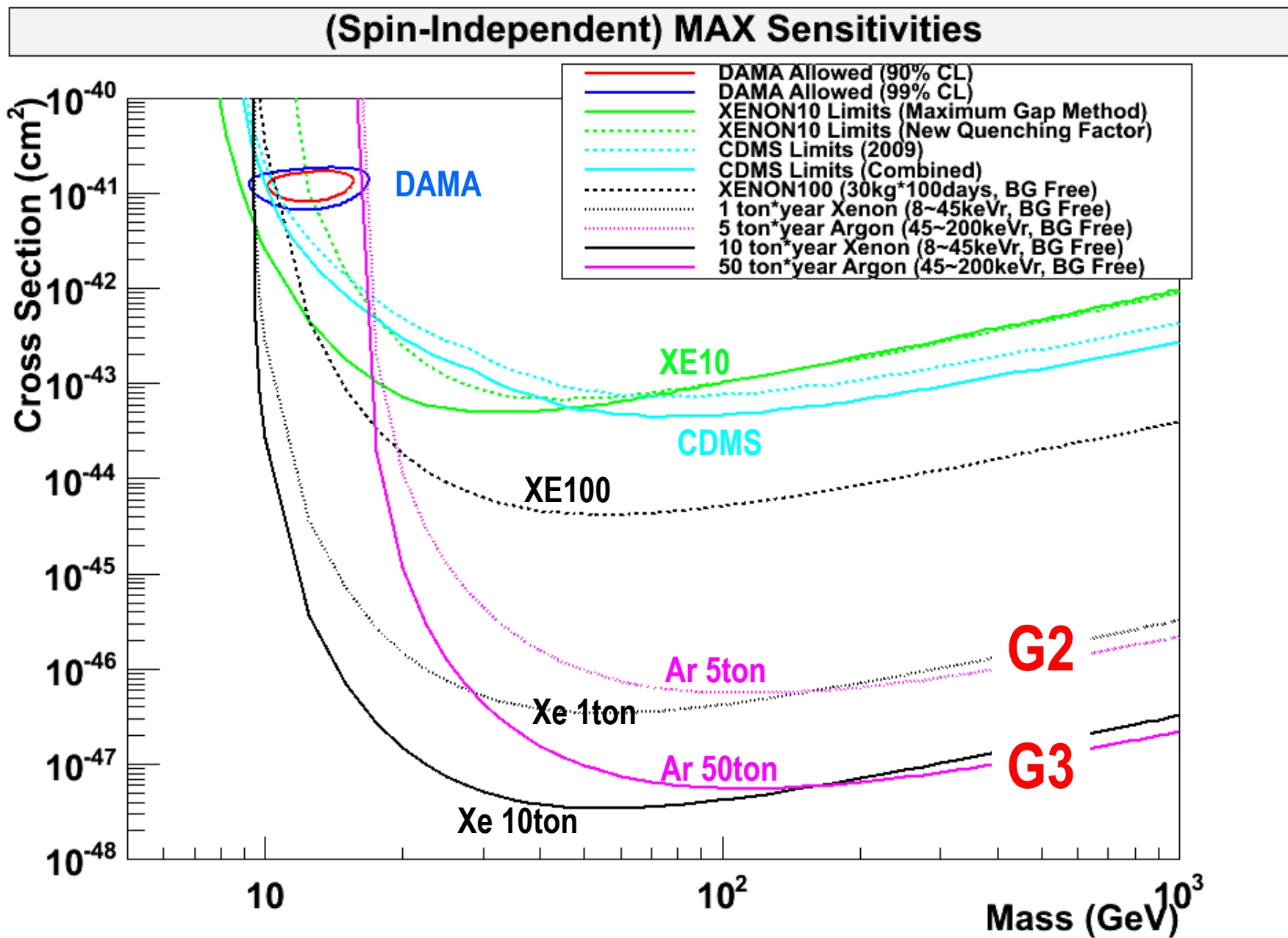

Target Mass Dependence of WIMP Cross Section

cross section 10^{-44} cm^2 , WIMP mass 100 GeV

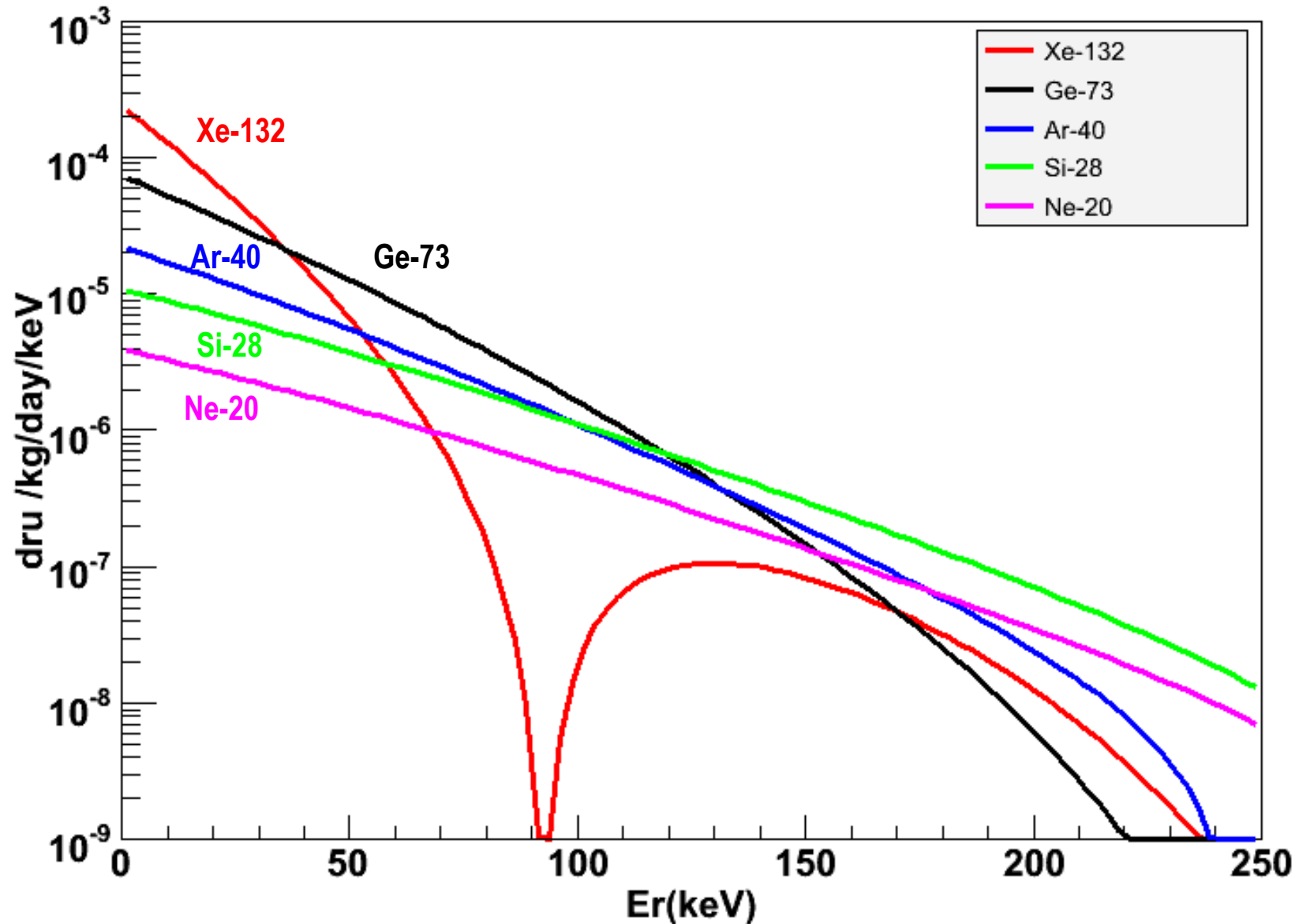

(SI) WIMP Energy Spectrum for LXe (Cross Section = 10^{-45}cm^2)

(SI) WIMP Recoil Energy Spectrum for LXe ($\sigma = 10^{-45} \text{cm}^2$)

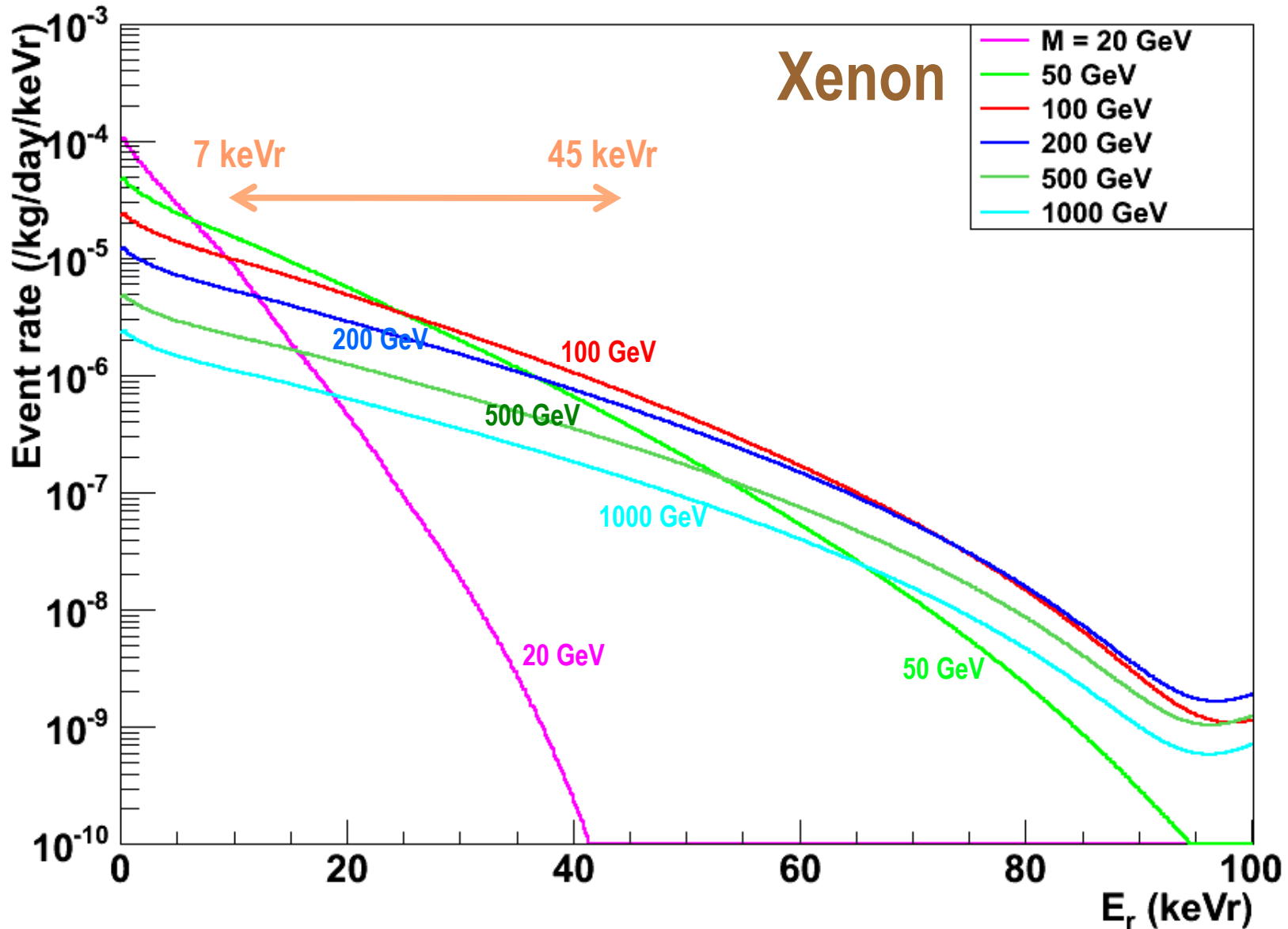

(SI) WIMP Energy Spectrum for LAr (Cross Section = 10^{-45}cm^2)

(SI) WIMP Recoil Energy Spectrum for LAr ($\sigma = 10^{-45} \text{cm}^2$)

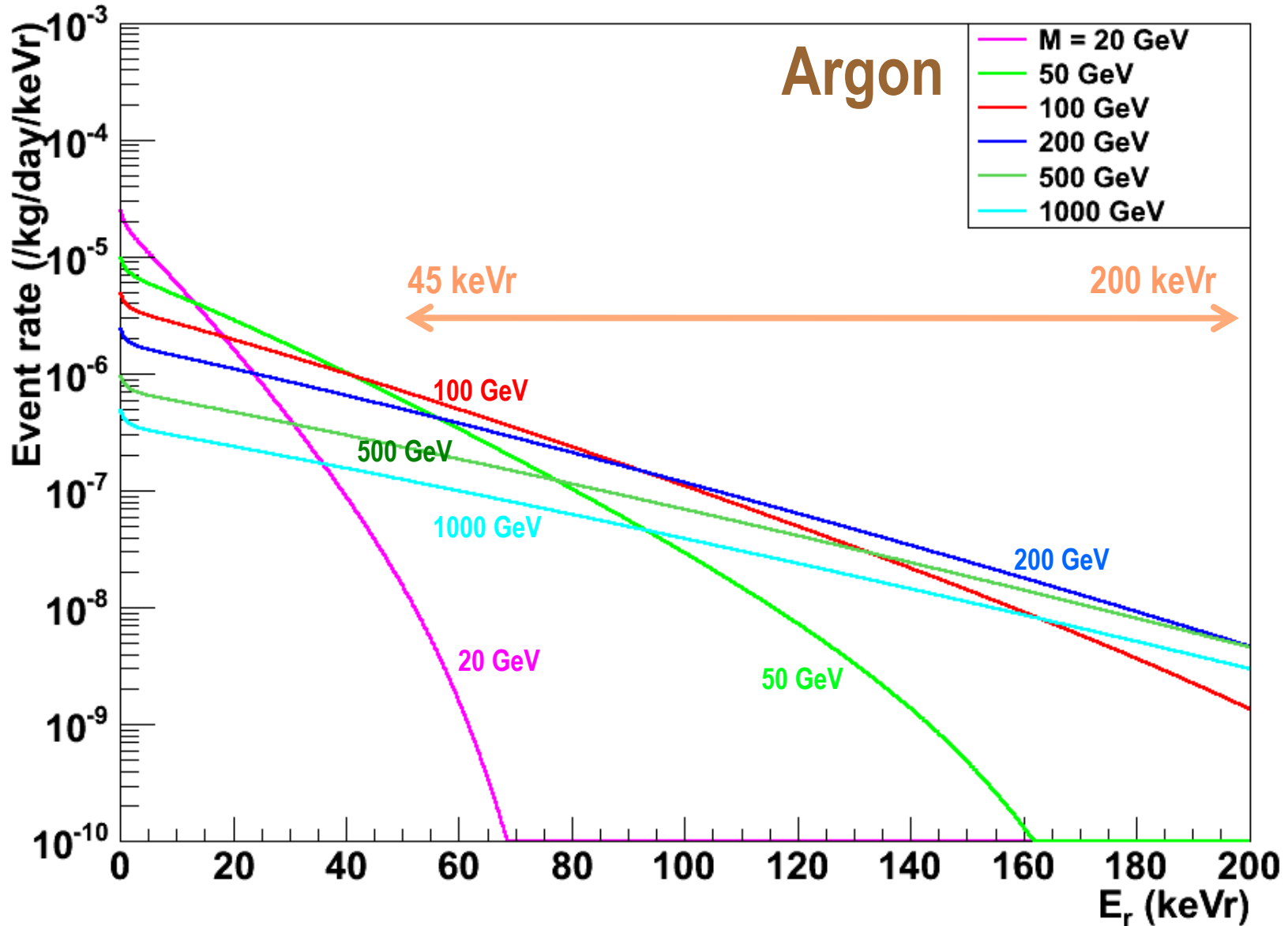

1- σ Error of WIMP Mass vs SI Cross Section (10 ton*year Xe and 50 ton*year Ar)

1- σ Error of WIMP Mass and SI Cross Section

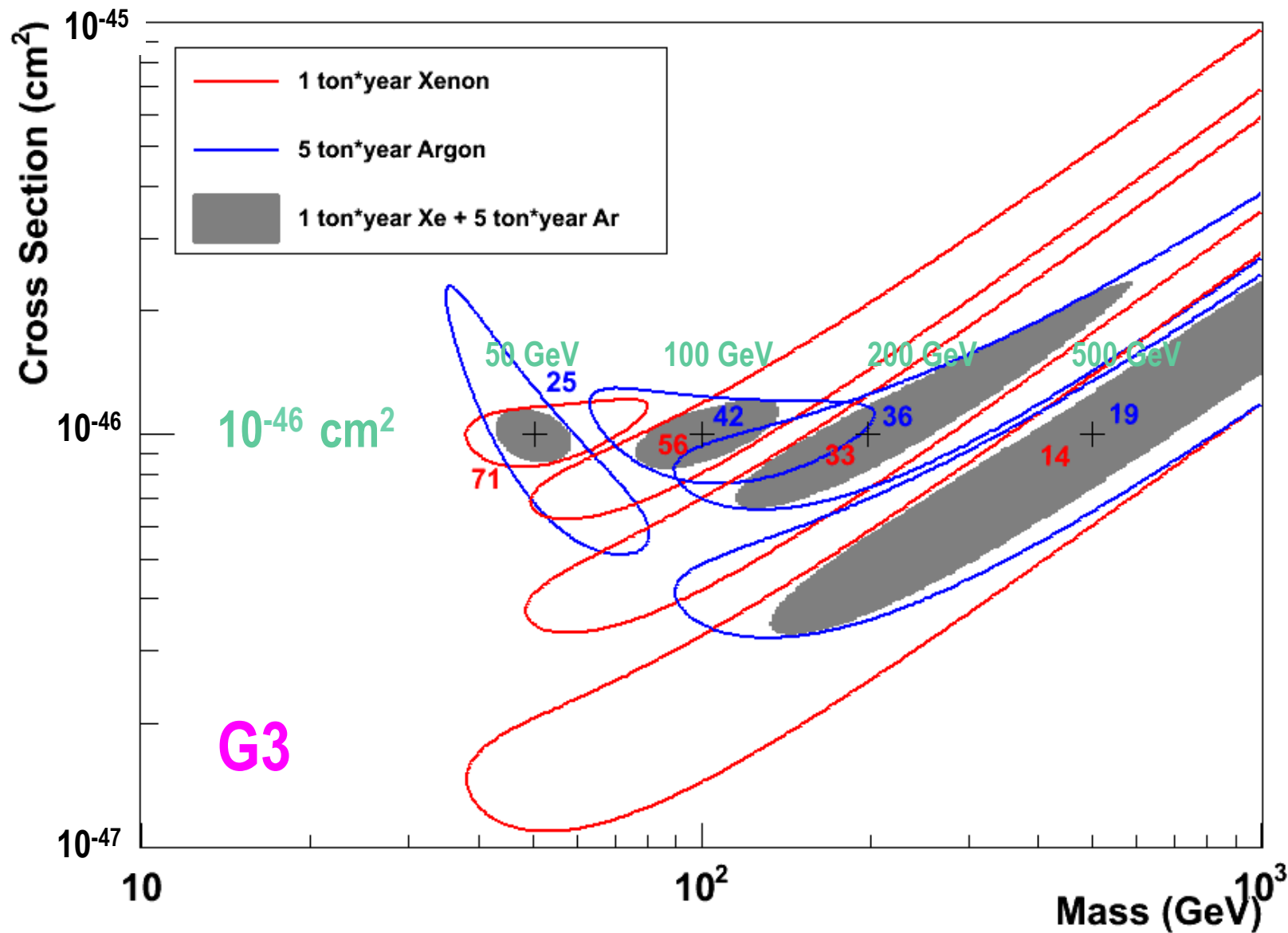

1- σ Error of WIMP Mass vs SI Cross Section (10 ton*year Xe and 50 ton*year Ar)

1- σ Error of WIMP Mass and SI Cross Section

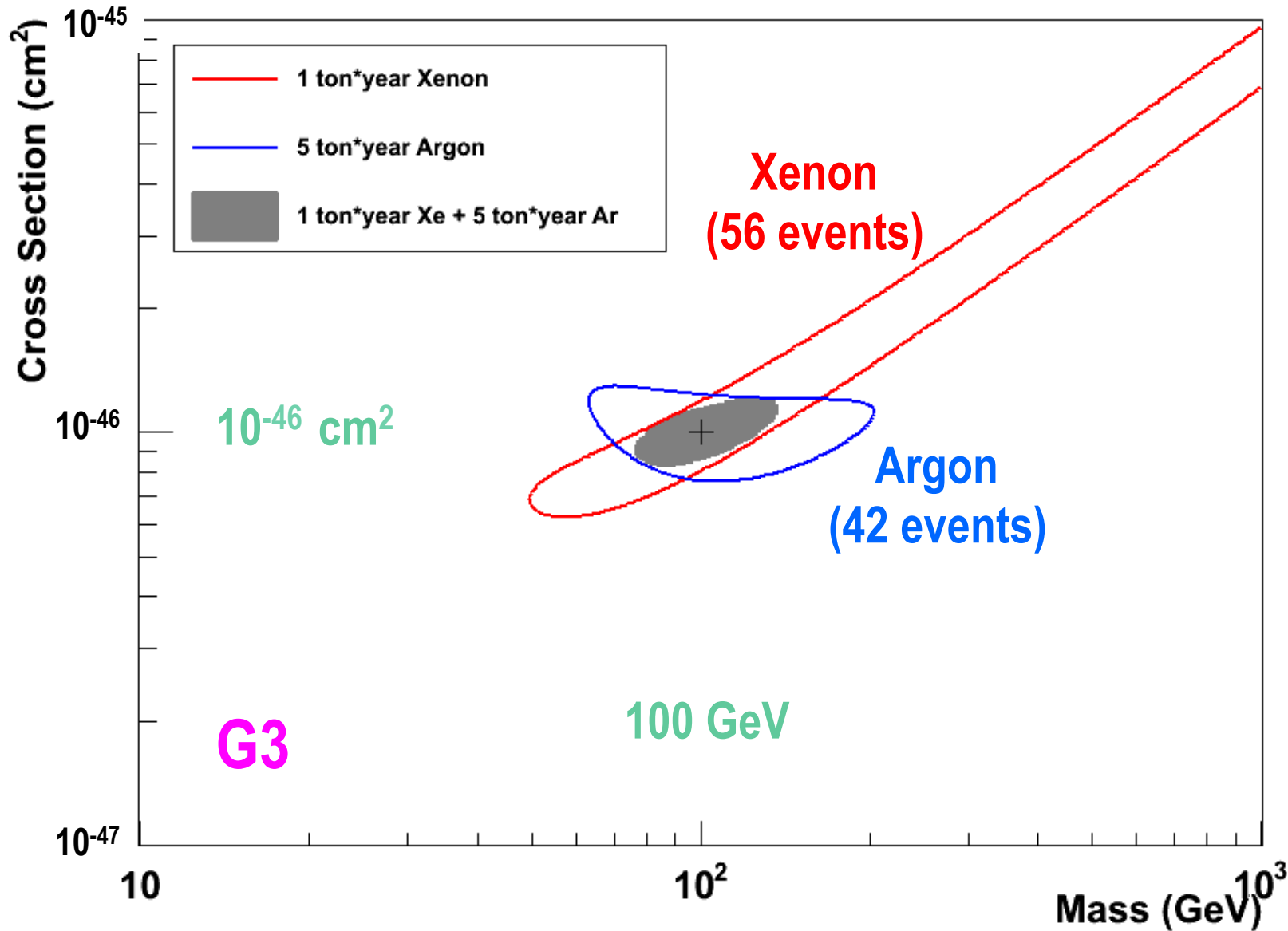

1- σ Error of WIMP Mass vs SI Cross Section (10 ton*year Xe and 50 ton*year Ar)

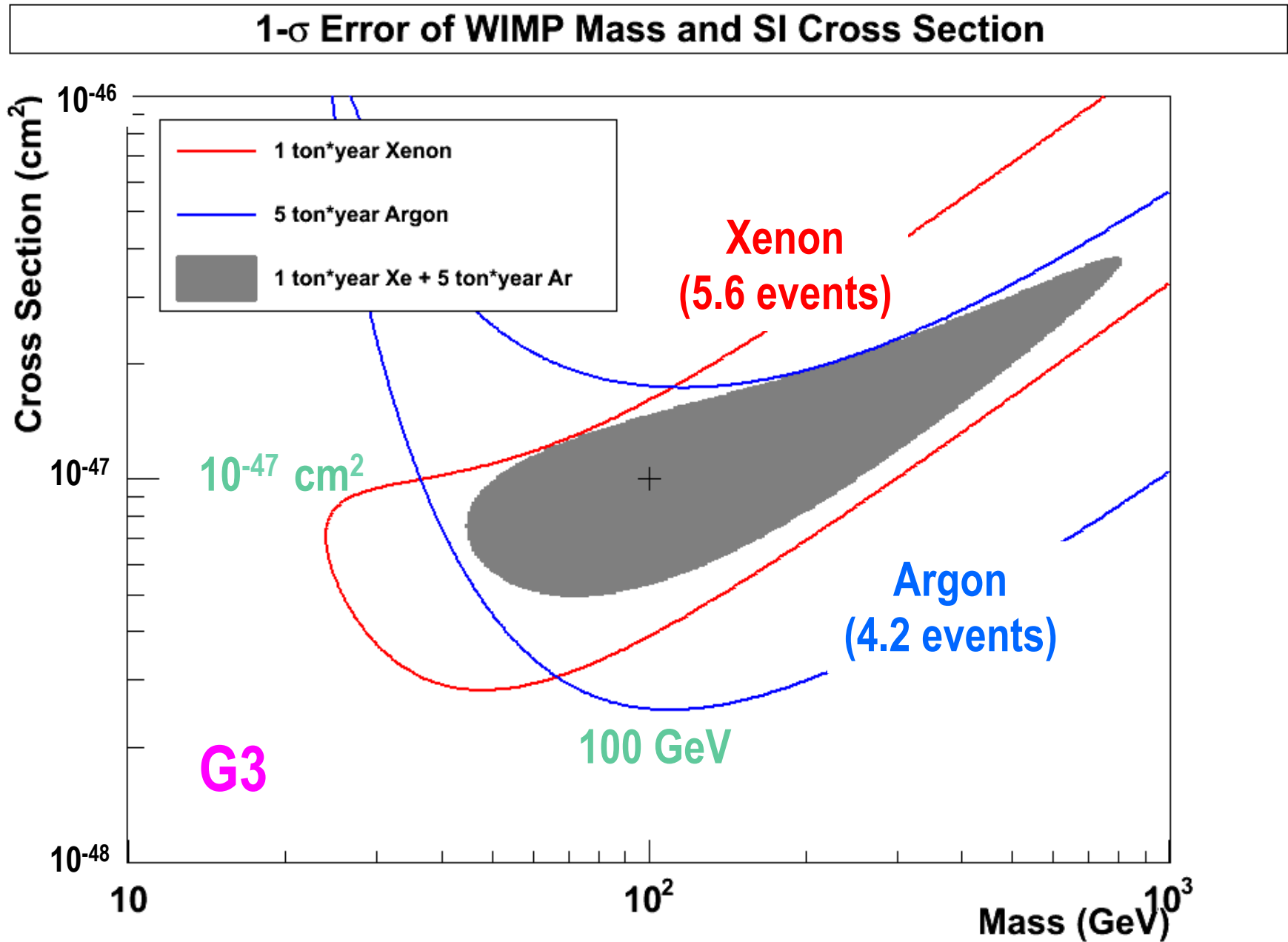

Xenon 10 ton Detector (2m x 2m)

Xenon 10 Ton Detector Structure

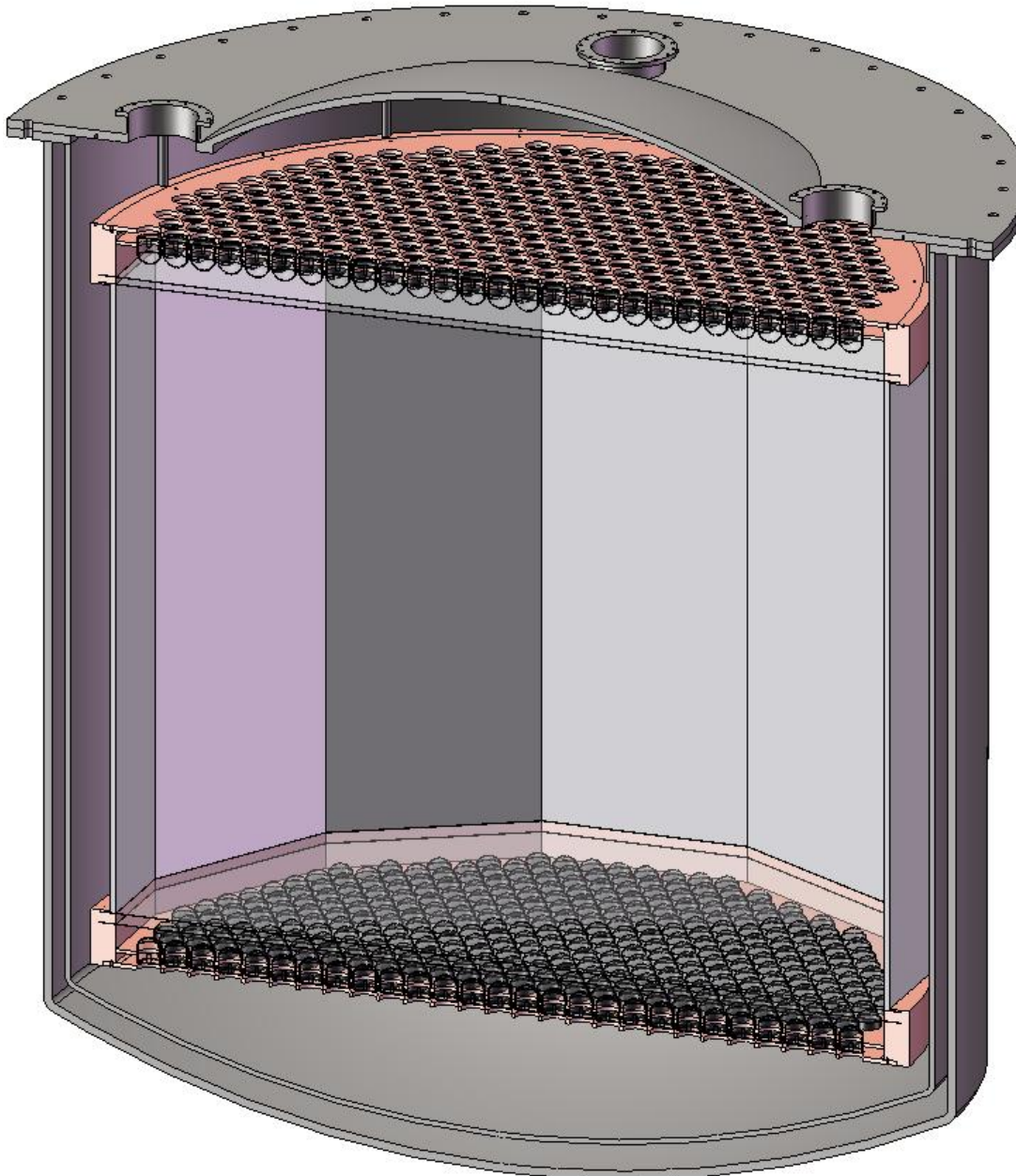

Top: 3" QUPID x 595
Bottom: 3" QUPID x 595

Xenon 10 Ton Detector Structure

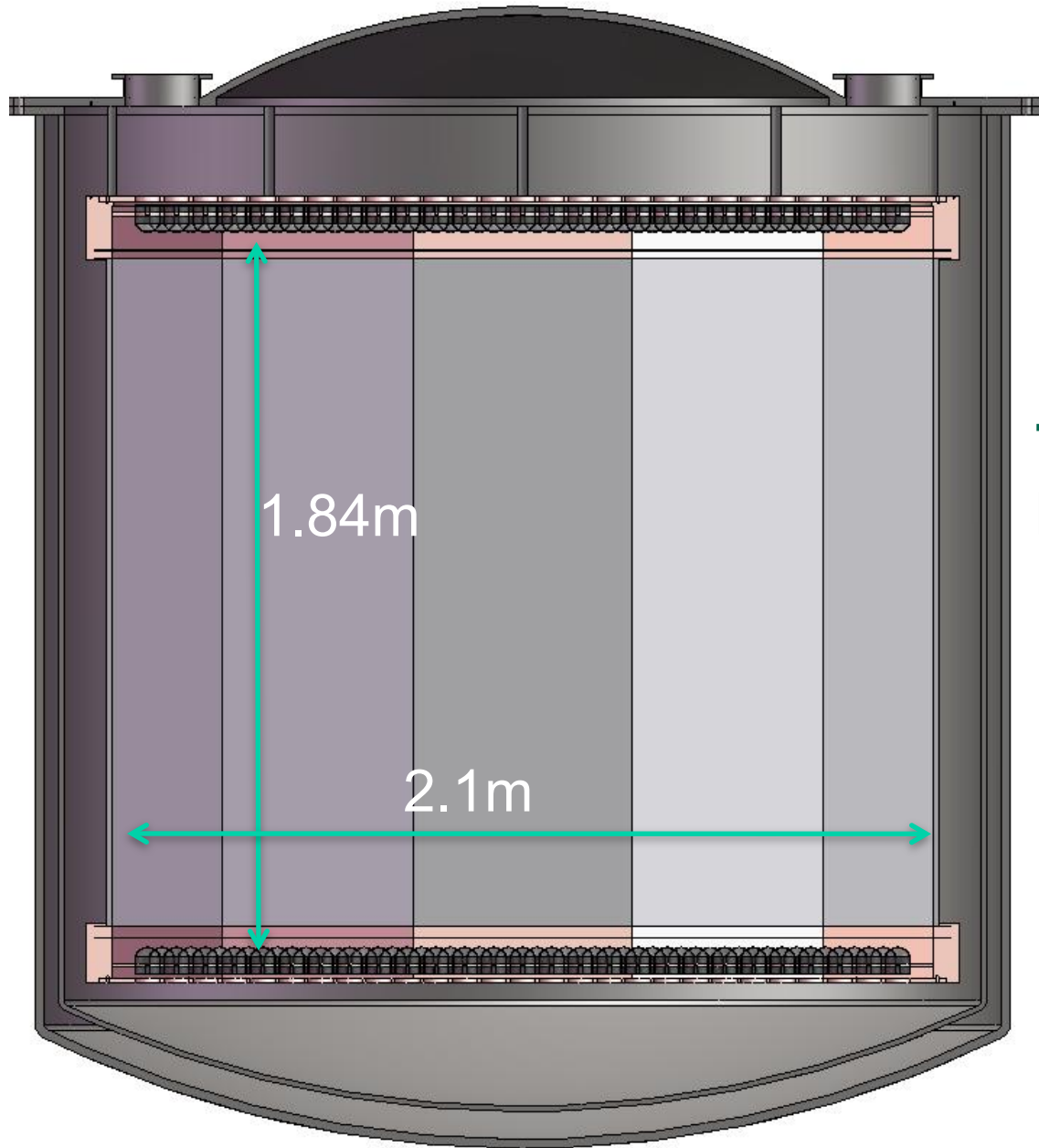

Top: 3" QUPID x 595
Bottom: 3" QUPID x 595

Xenon 10 Ton Detector Structure

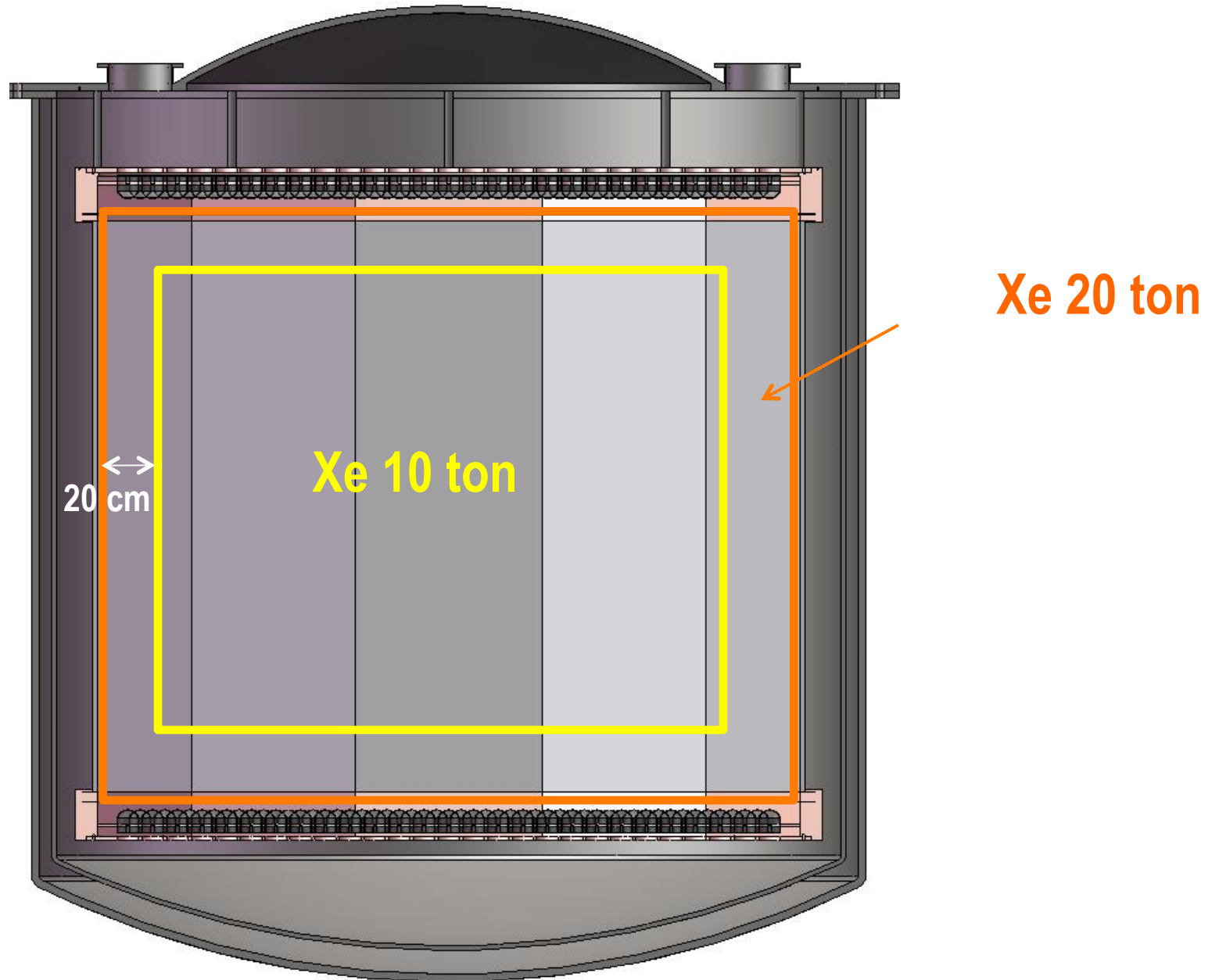

Xenon 10 Ton Top corner

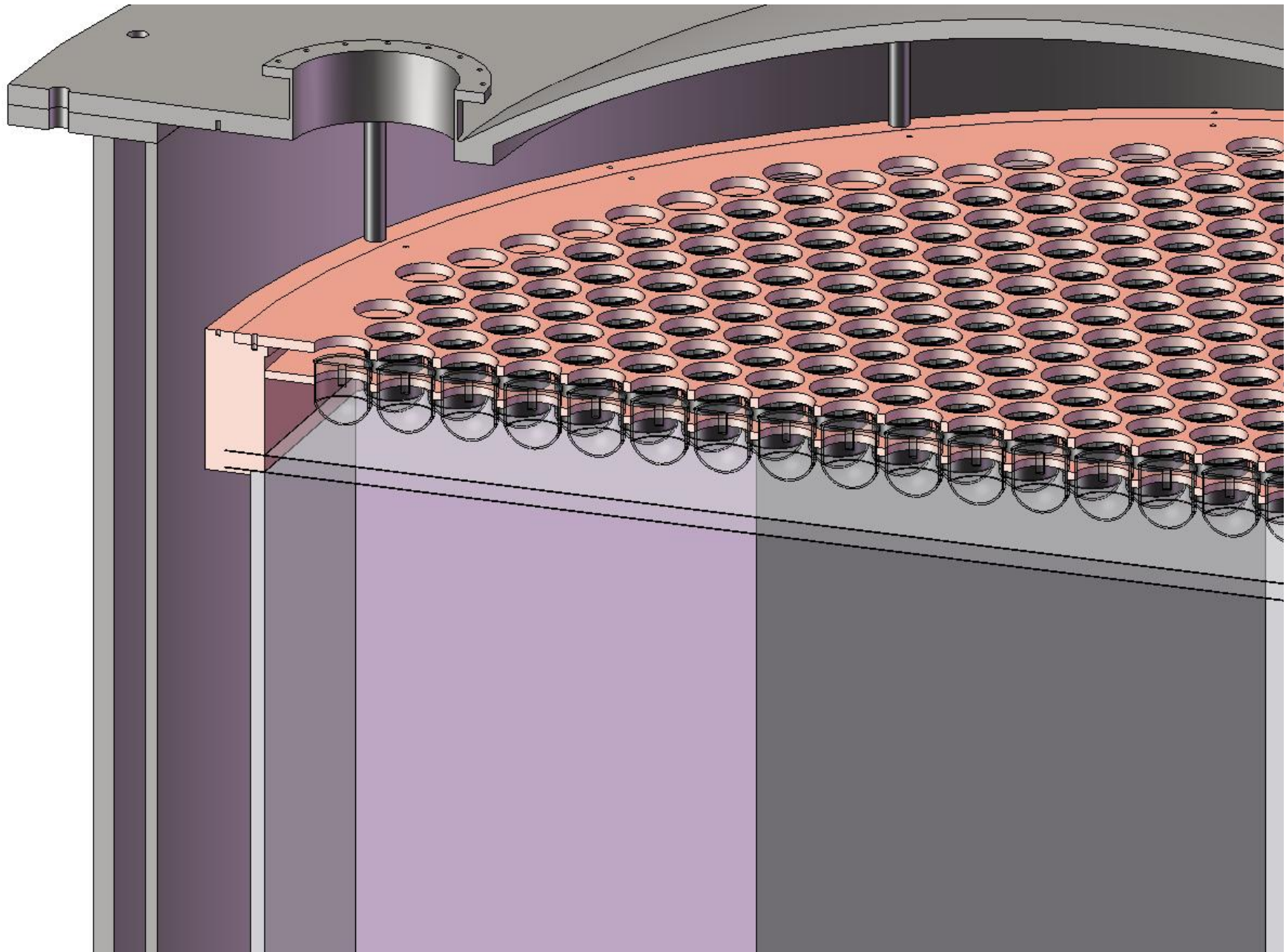

Argon 50 ton Detector (4m x 4m)

Argon 50 ton Detector Structure

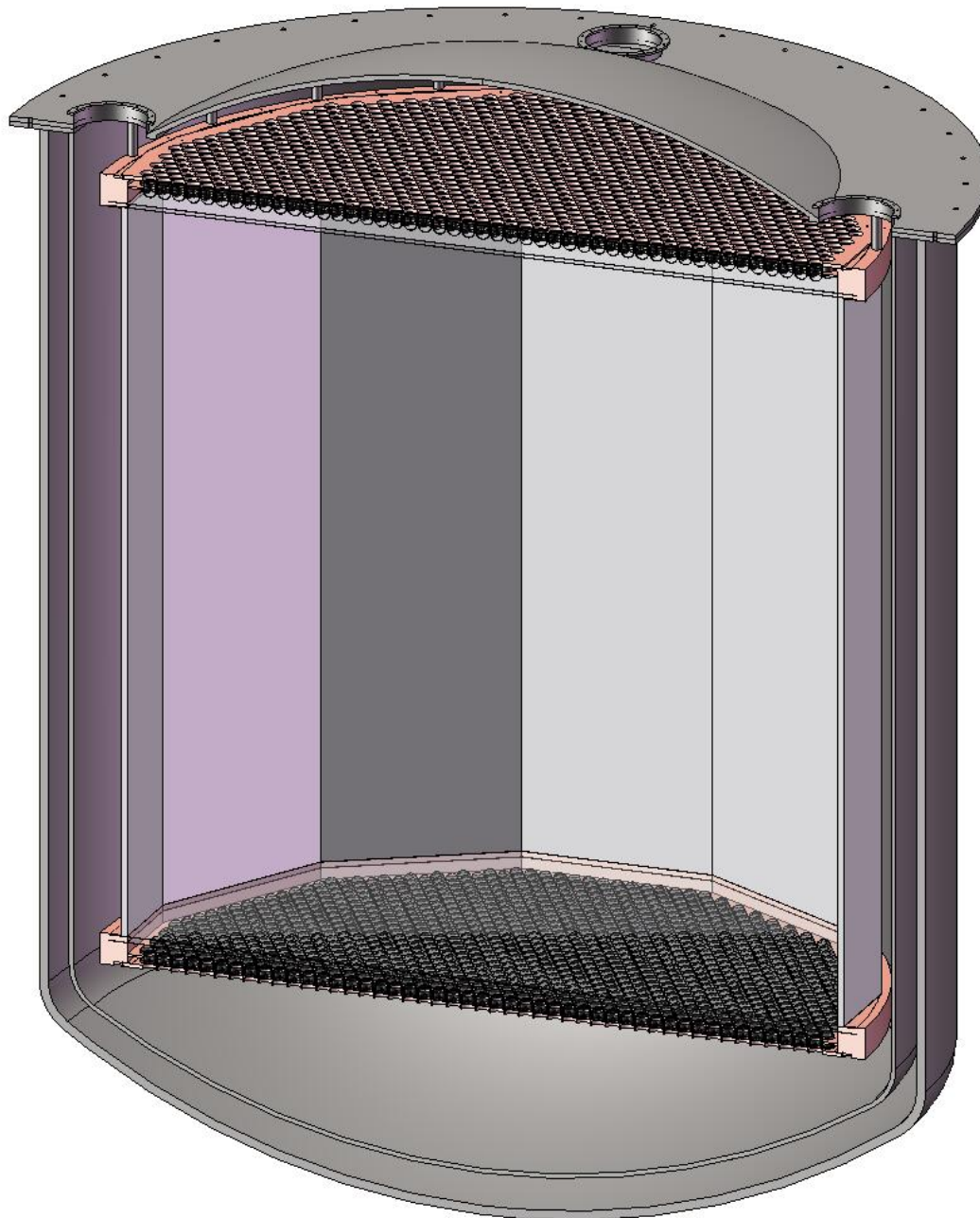

Top: 3" QUPID x 2644
Bottom: 3" QUPID x 2644
Total: 3" QUPID x 5288

Argon 50 ton Detector Structure

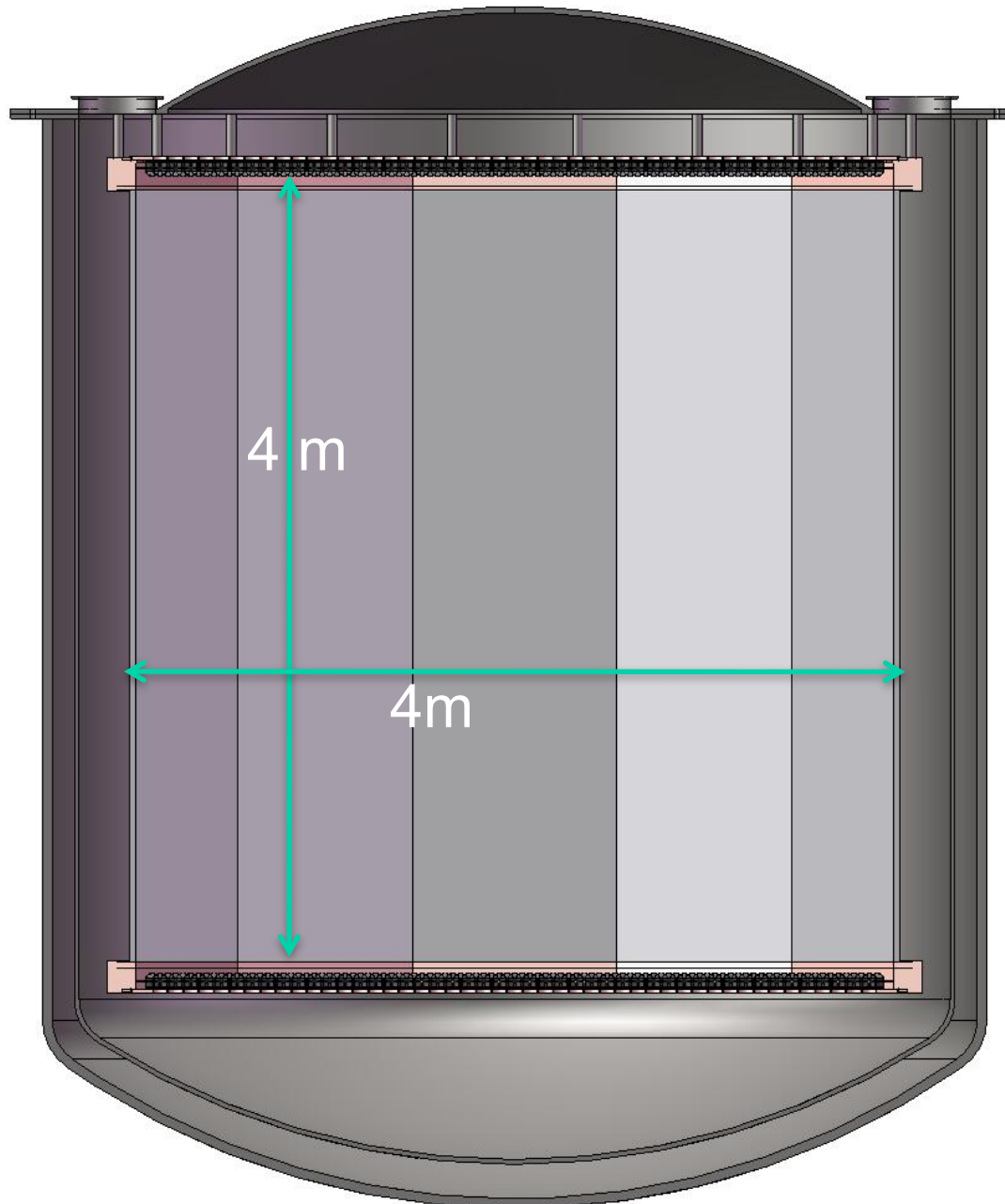

Top: 3" QUPID x 2644
Bottom: 3" QUPID x 2644
Total: 3" QUPID x 5288

Argon 50 ton Detector Structure

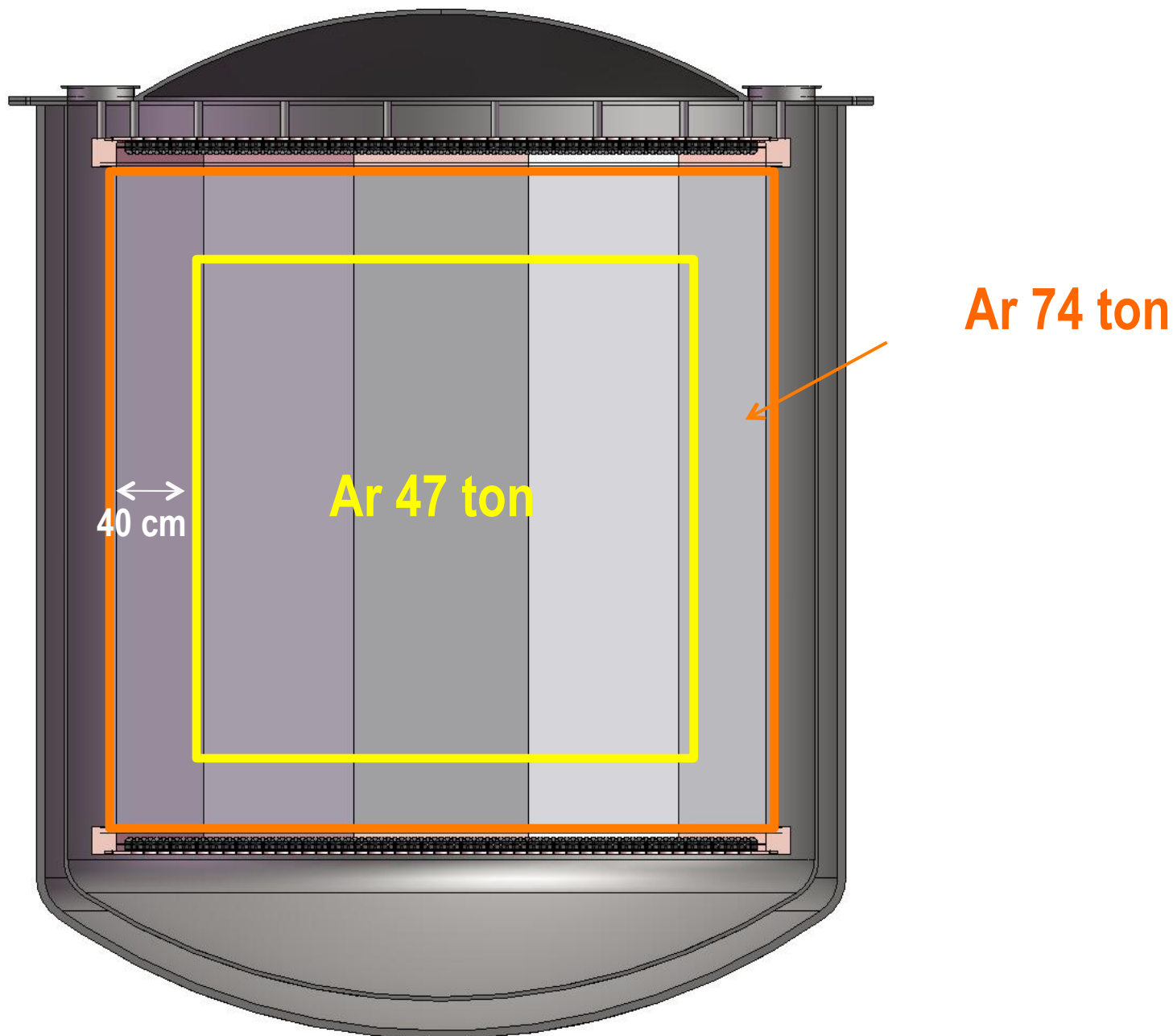

Status of QUPID

New QUPID (Production Version)

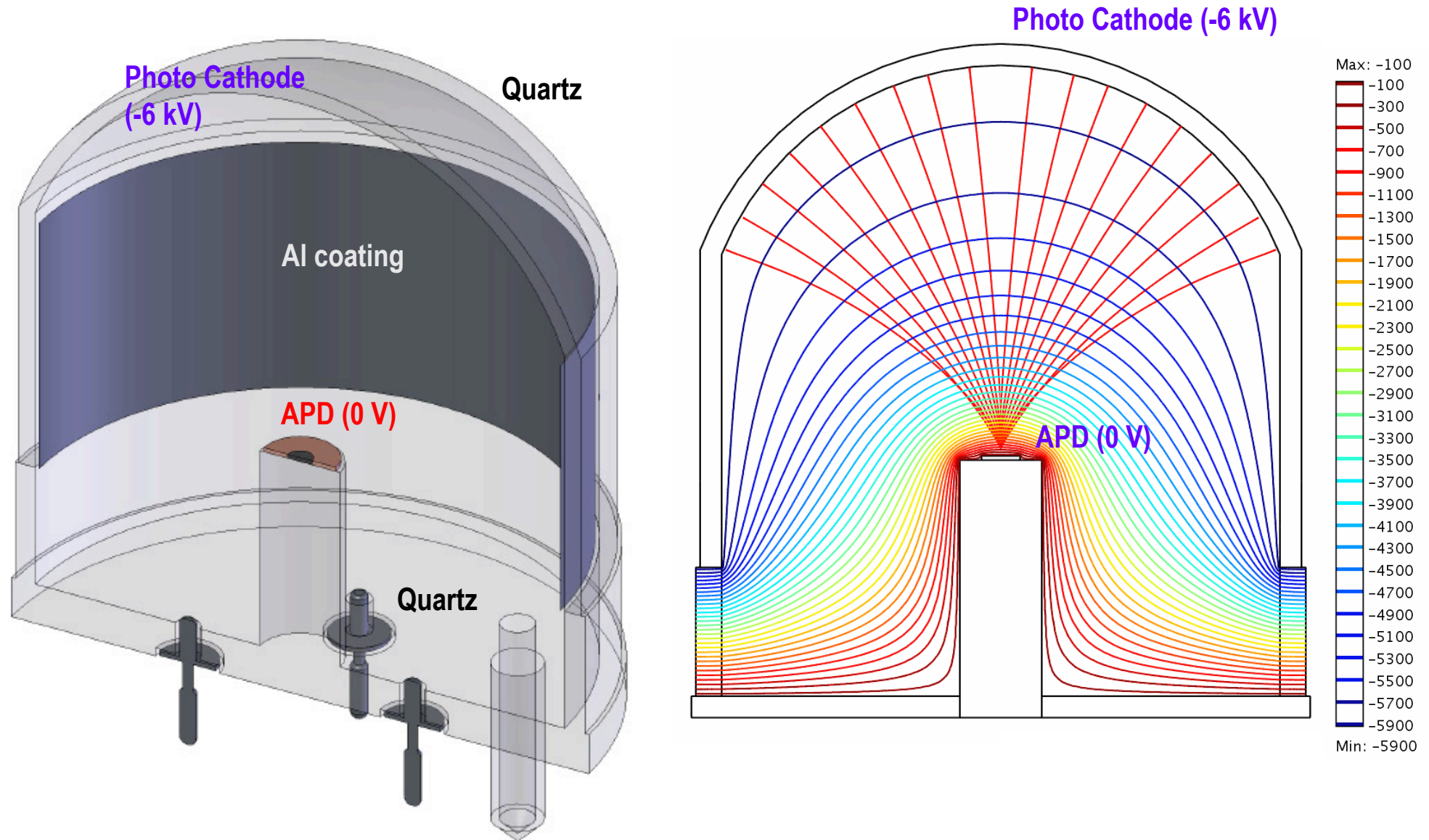

New 3" QUPID (Production Version)



Spectrum of QUPIDs and Background (4 QUPIDs x 1 month data)

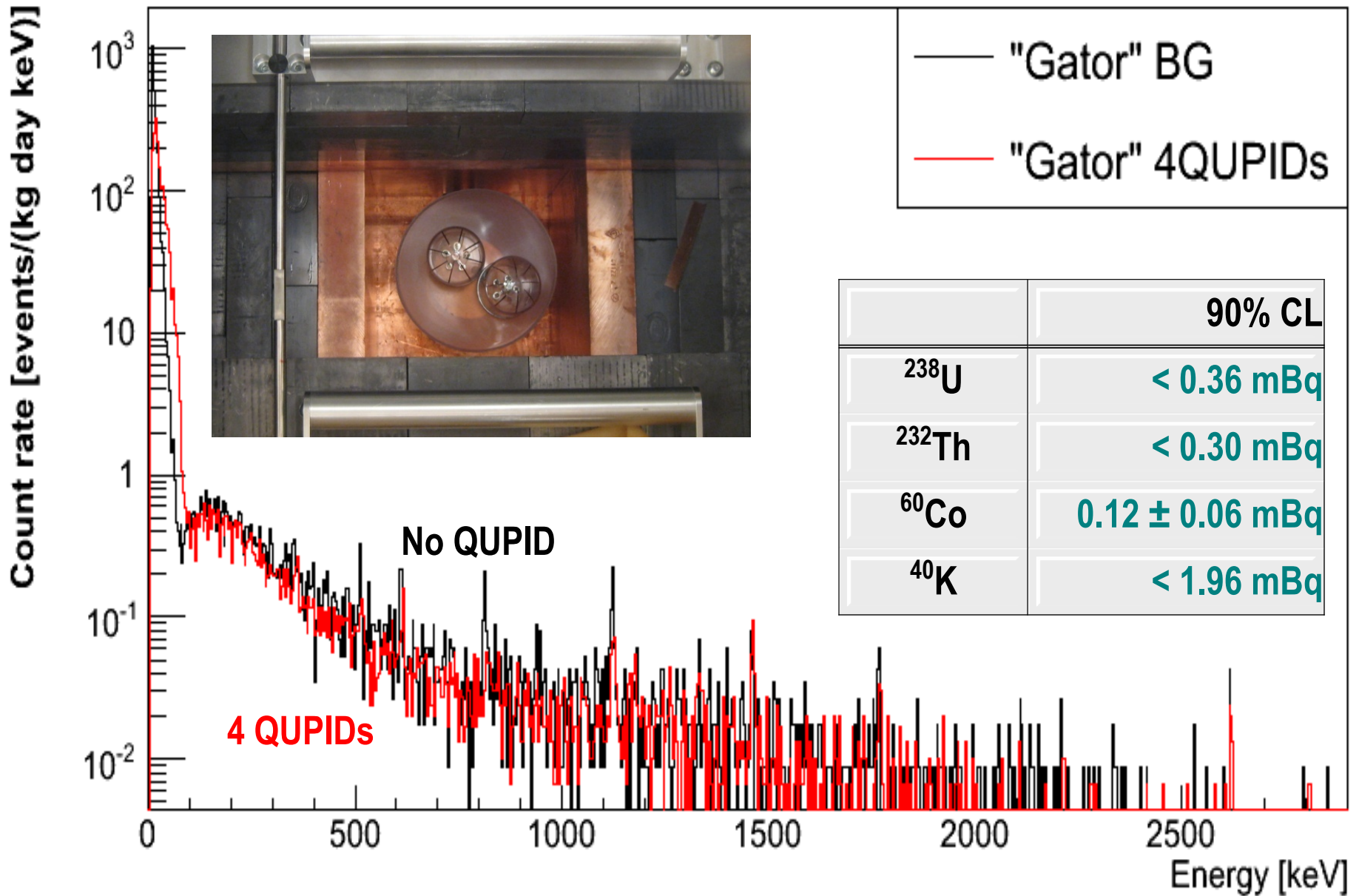

Quantum Efficiency (QHA63, 64)

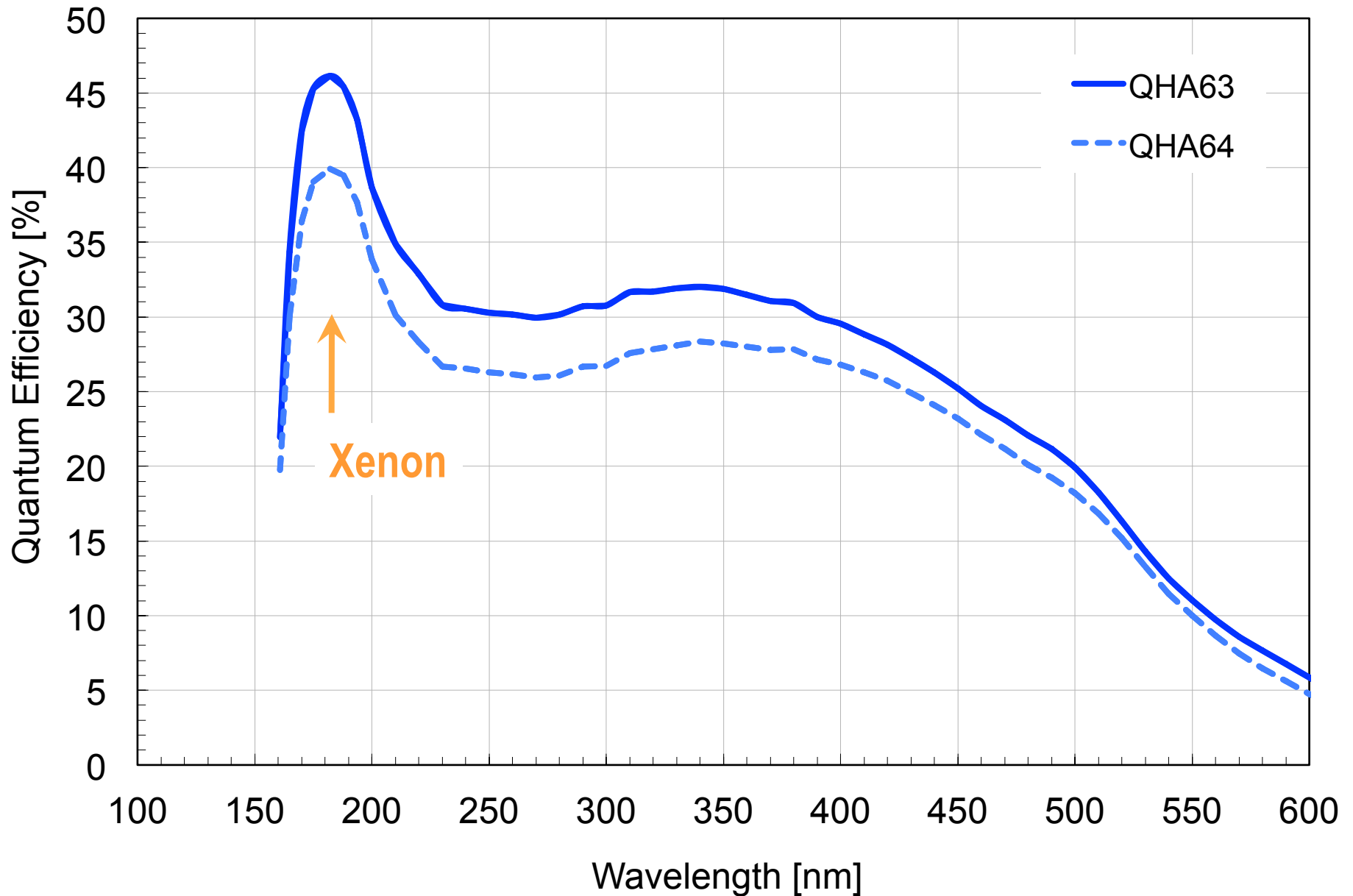

Cathode current with -5% non-linearity

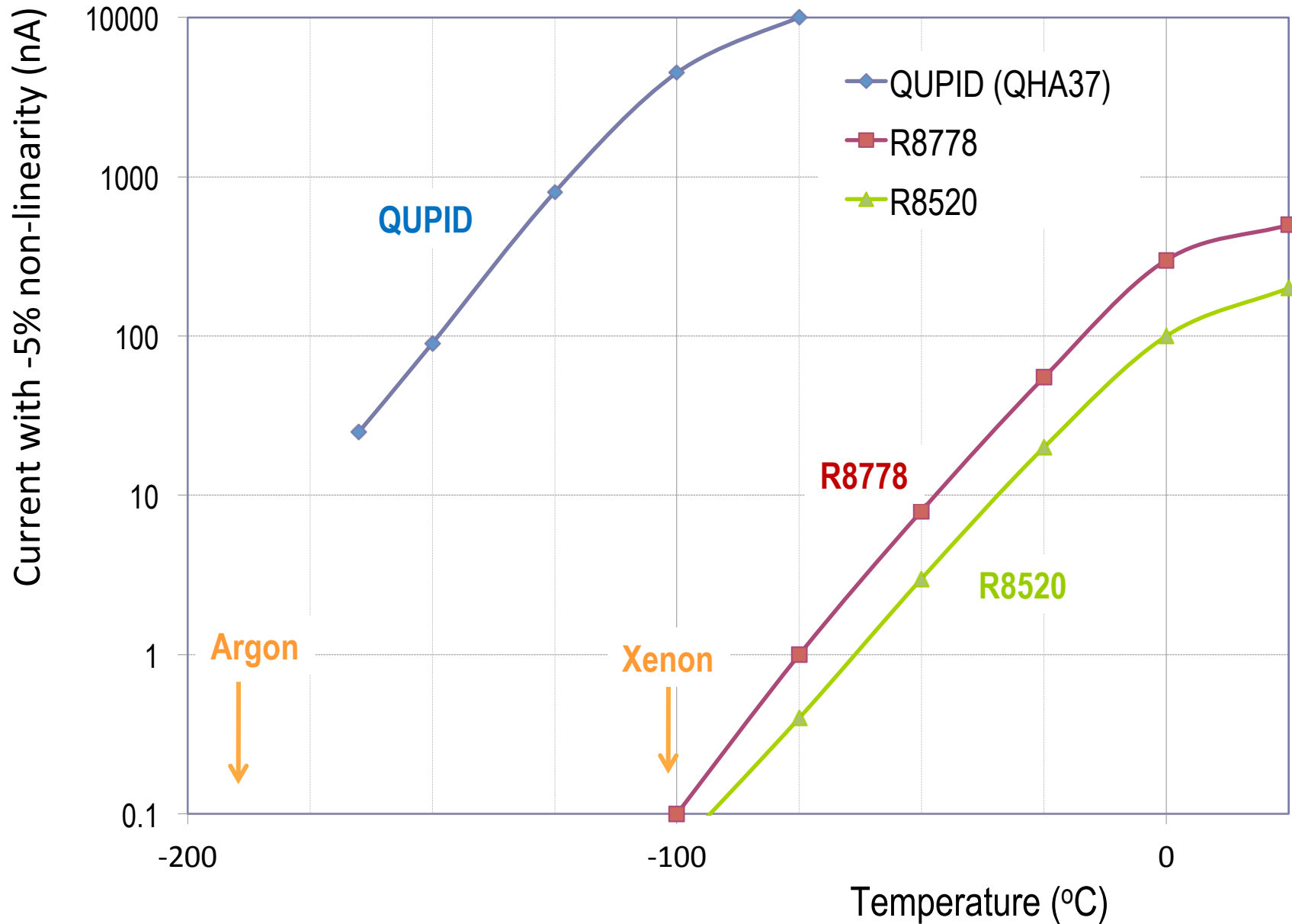

1, 2 and 3 PE Distribution with 2m cable

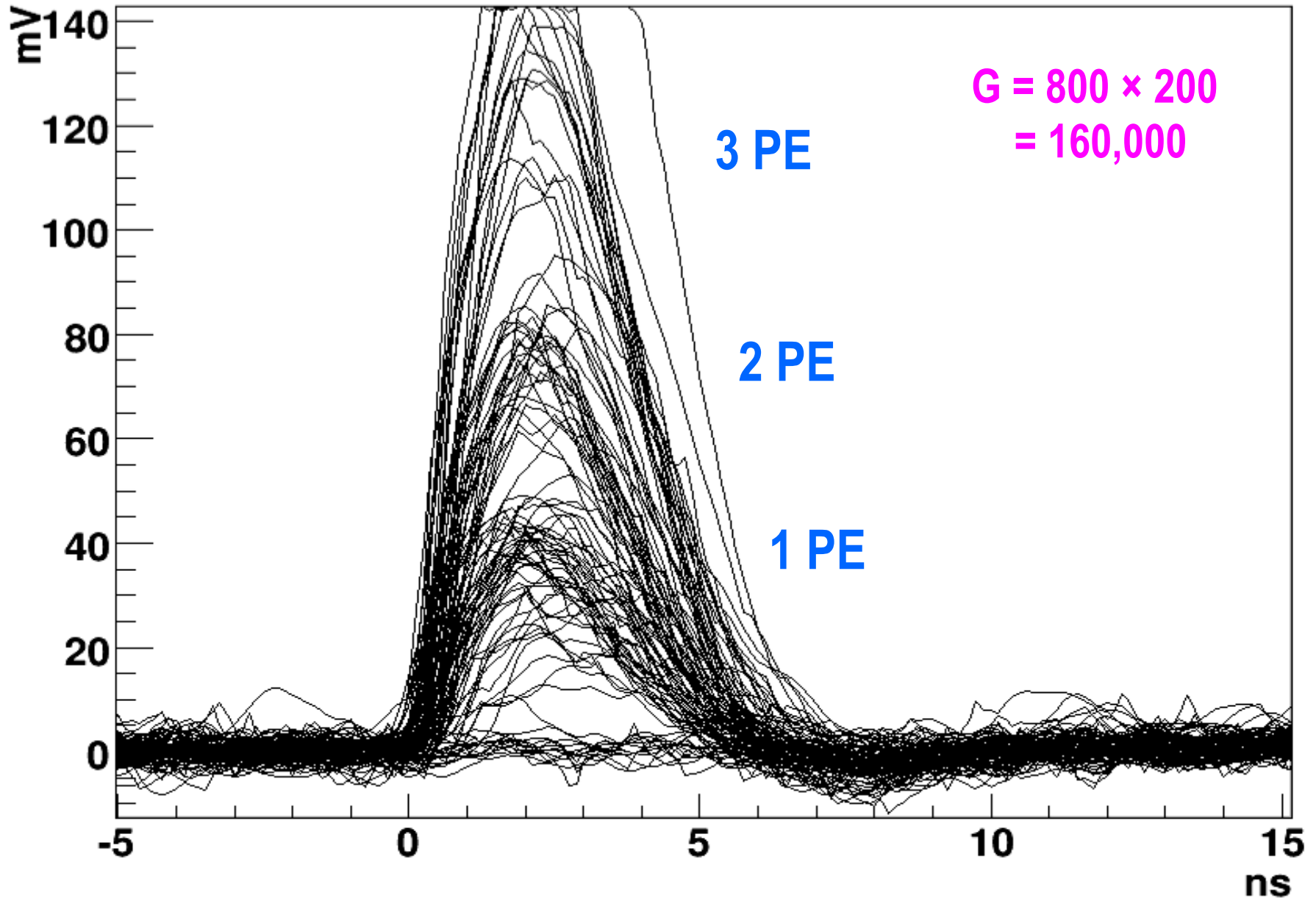

Cryogenic System at UCLA (Hanguo Wang's Lab)

Nitrogen

Liquid Xe

Artin Teymourian

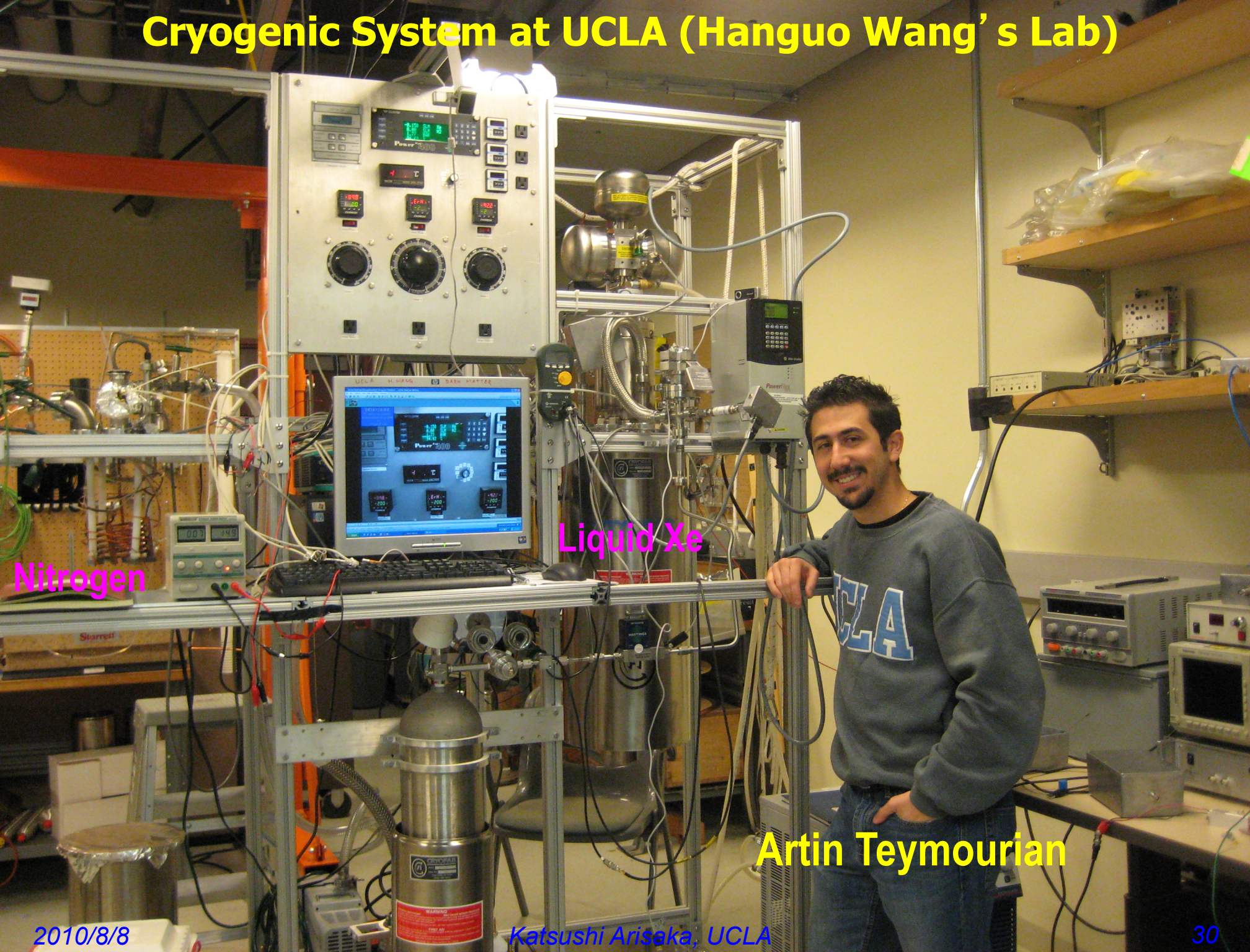

The first Scintillating lights detected by QUPID from ^{57}Co in Liquid Xenon

1, 2, and 3 Photoelectron Peaks

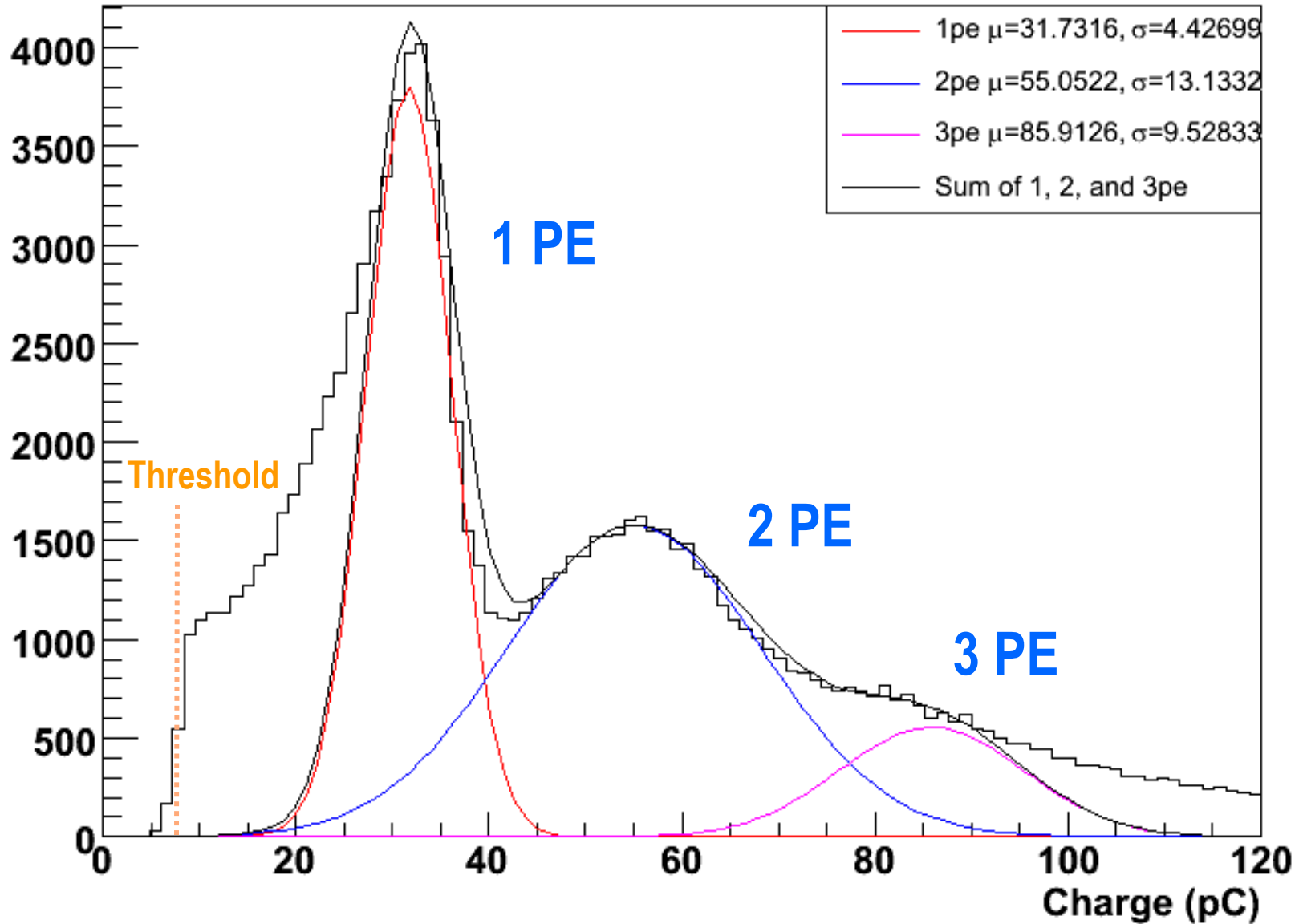

Summary of QUPID

- **Extremely low radioactivity:** < 1 mBq
 - < 0.1 neutron / year
 - < 10 times lower than conventional low radioactive PMTs.
- **Large diameter:** 3 inch
- **Special Photocathode:** Bialkali LT
 - 46 % QE at 178 nm
 - Low resistivity even at Liquid Ar temperature (- 185 °C)
- **True photon counting.**
 - 1, 2, 3... photoelectron peaks clearly visible.
 - 100% collection efficiency.
- **Simple HV supply.**
 - Common HV (-6 kV) for all QUPIDs
 - Resister chain not necessary
- Successful operation in Liquid Xenon at UCLA

Conclusions

➤ **MAX + LZD = “G3”**

- Xenon 10 Ton + Argon 50 Ton (Fiducial)
- 3” QUPID at top/bottom only

➤ **Physics sensitivities:**

- ~ 5 events / year / detector, if 100 GeV, 10^{-47} cm²
- Mass and Cross Section by Energy Spectrum
- WIMP Velocity by Annual Modulation

➤ **QUPID development nearly complete**

- > 45% QE by new photocathode
- Operation in Liquid Xenon/Argon underway