

# **Why are we here?**

## **Origin of the Universe and Life**

**Prof. Katsushi Arisaka**

***University of California, Los Angeles  
Department of Physics and Astronomy***

[arisaka@physics.ucla.edu](mailto:arisaka@physics.ucla.edu)



**Why are we here?**

# Seven Phases of Cosmic Evolution

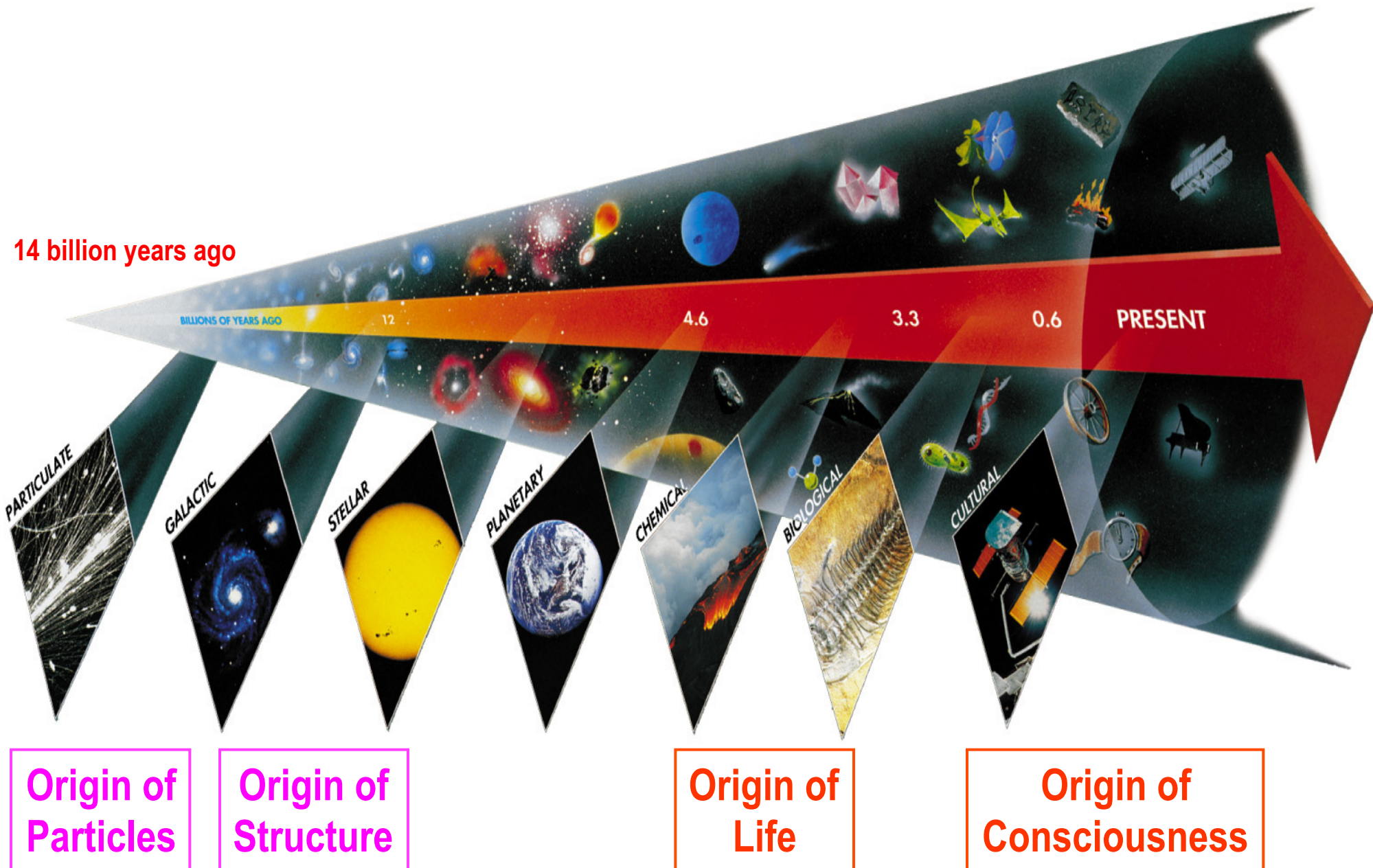

# Talk Outline

## ➤ Prof. Katsushi Arisaka

- Origin of Universe
- Origin of Particles
- Evolution of Universe

2:00 – 3:20

- *Cosmology*
- *Particle Physics*
- *Astronomy*

## ➤ Daniel Aharoni

- Origin of Life
- Origin of Consciousness

3:30 – 5:00

- *Molecular Biology*
- *Neuroscience*

# Solar System

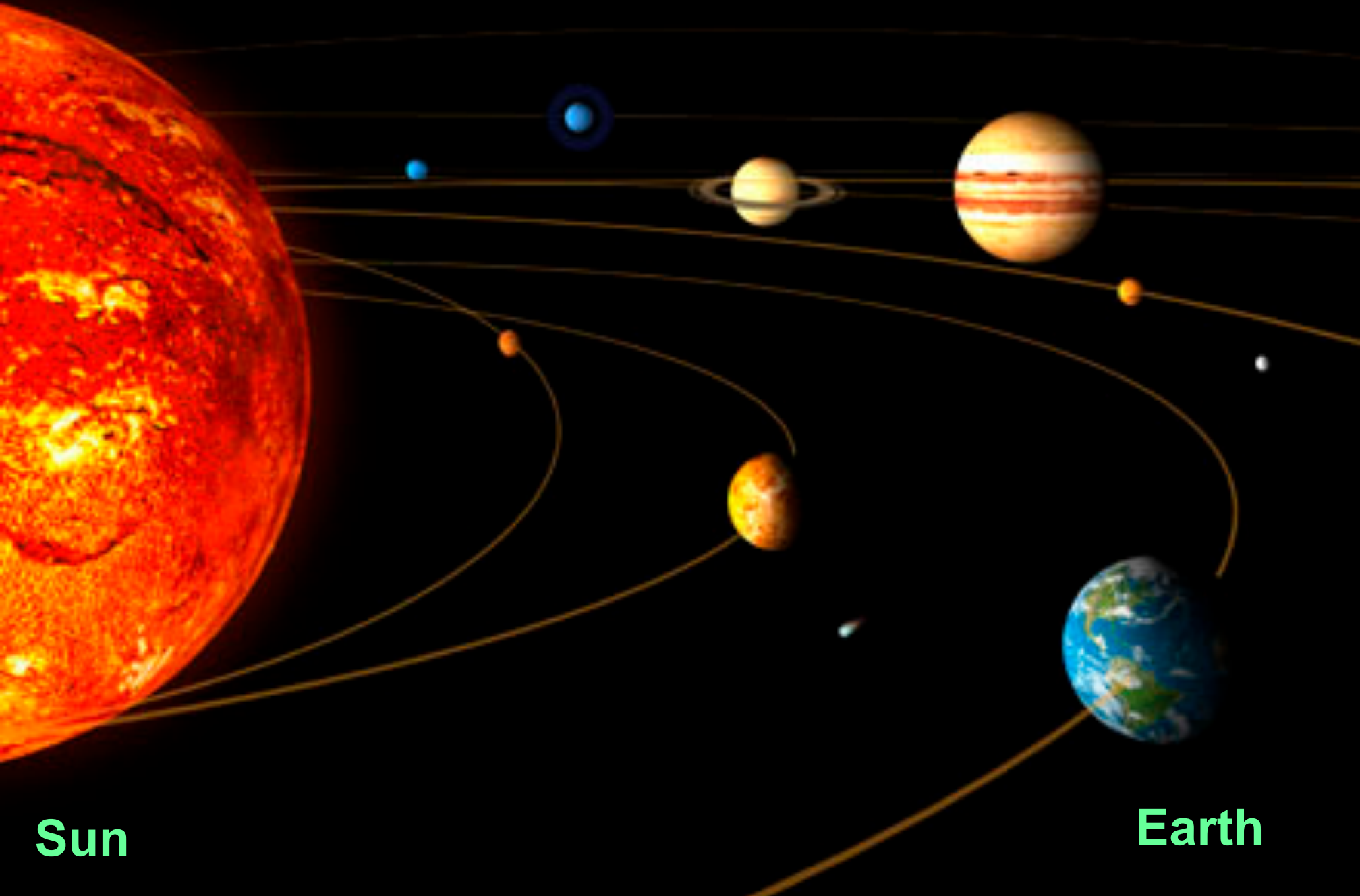

Sun

Earth

# Andromeda



**~100 Billions Stars in a Galaxy**



Keck Telescope

Subaru Telescope

Mauna Kea at Hawaii  
(4200m)

# Hubble Telescope



# Hubble Deep Field

The image displays a dense field of galaxies, including various types such as spiral, elliptical, and irregular galaxies, as well as numerous individual stars. The galaxies are scattered across the field, with some appearing as bright, distinct objects and others as faint, distant points of light. The overall appearance is a rich, multi-colored collection of celestial bodies against a dark background.

**~100 Billion Galaxies**

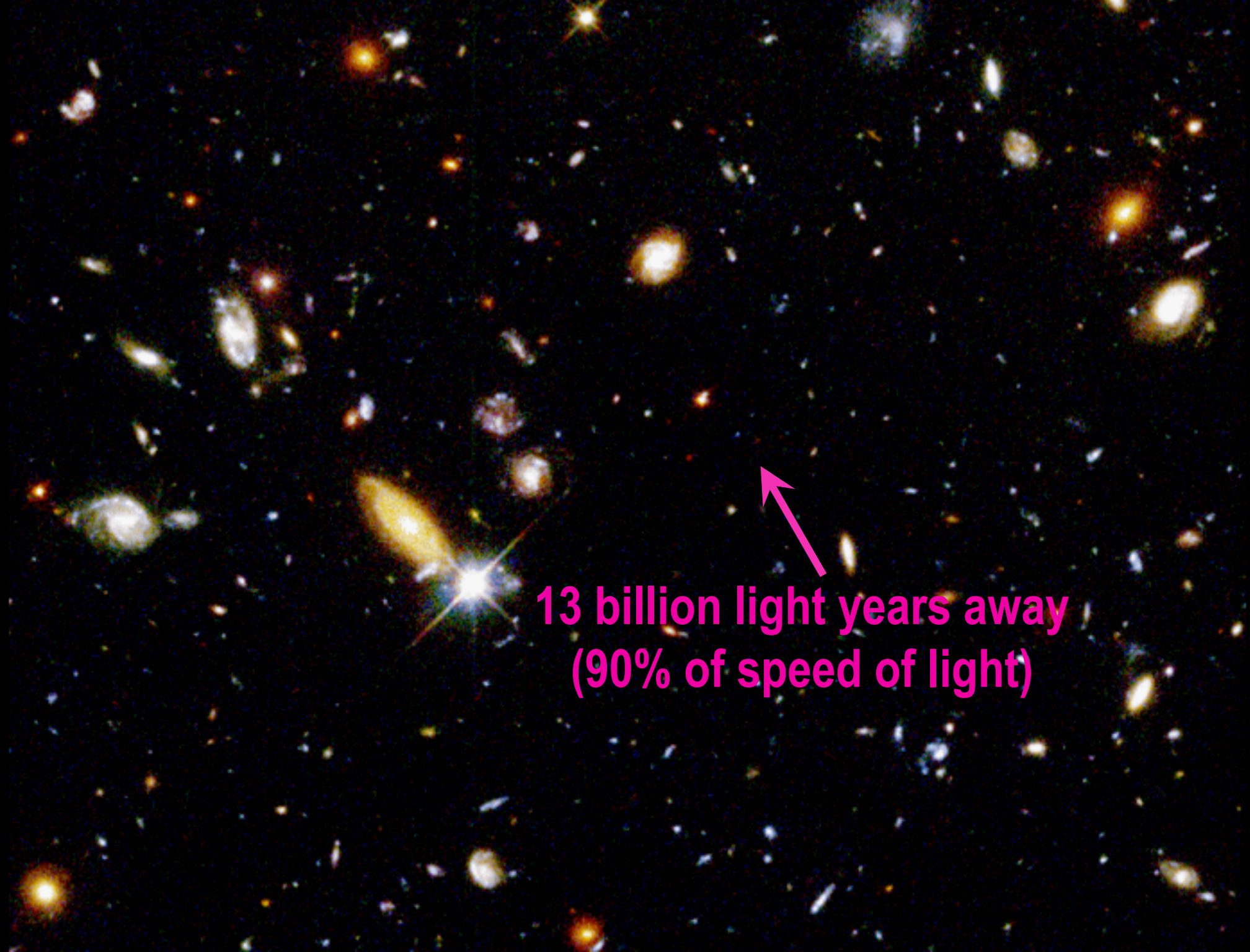

**13 billion light years away  
(90% of speed of light)**

# Hubble's Law: Expansion of the Universe

Horizon  
of Universe

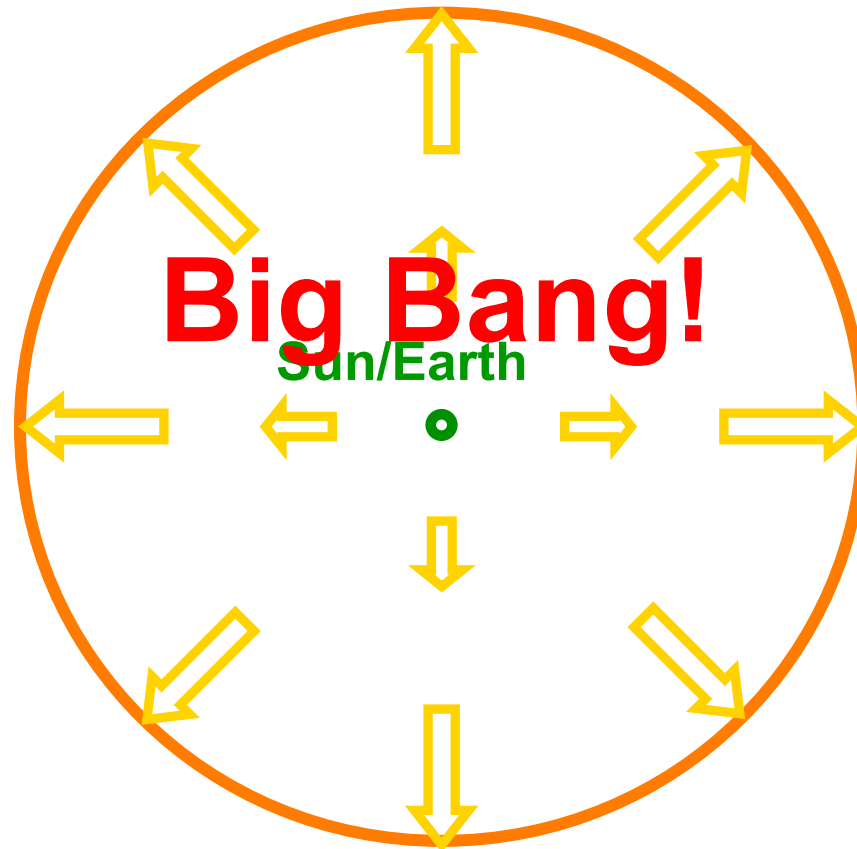

14 Billion  
Light Years

Moving Away  
at Speed of Light

# Expansion of Universe

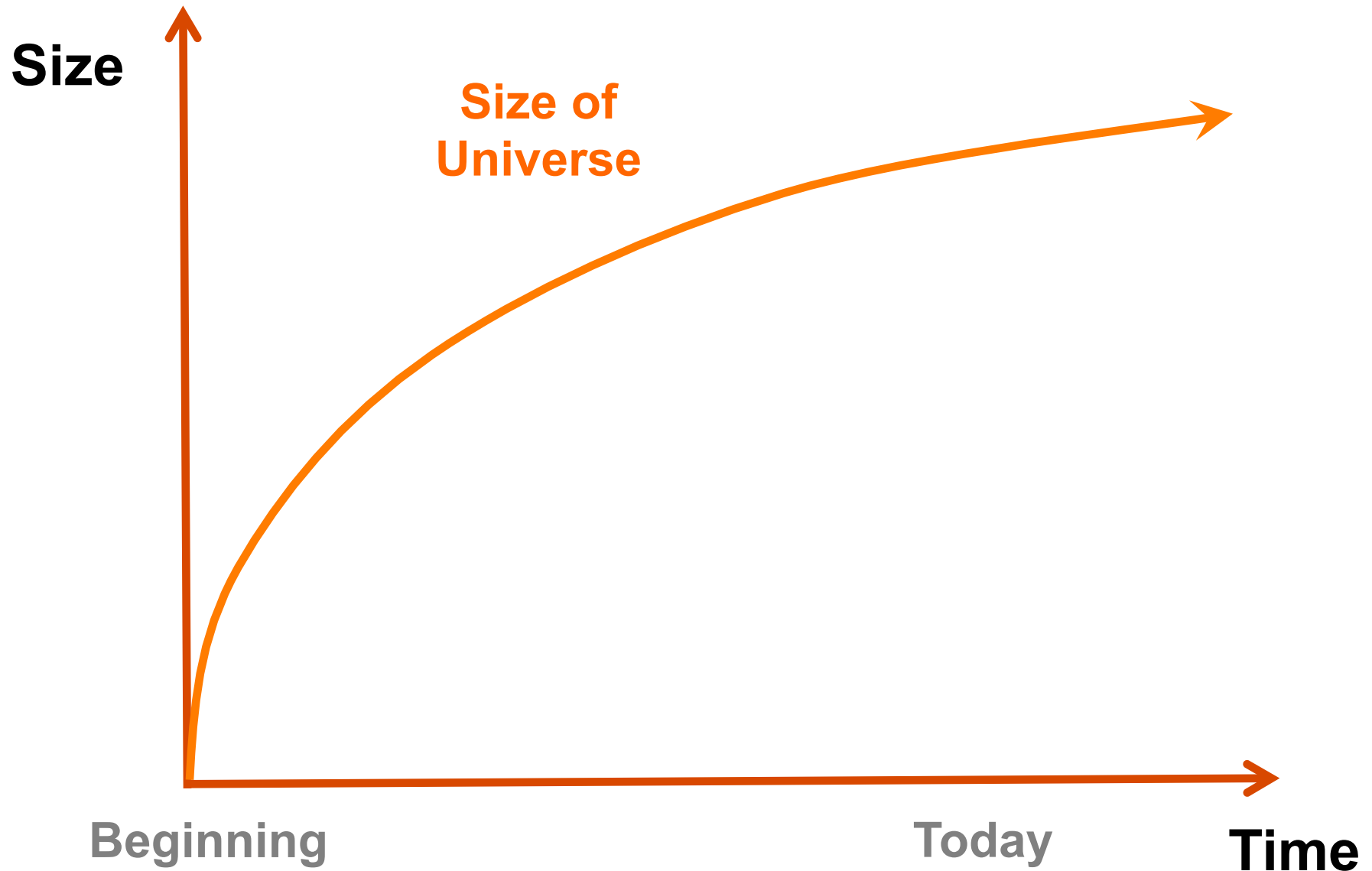

# Temperature of Universe

Temperature

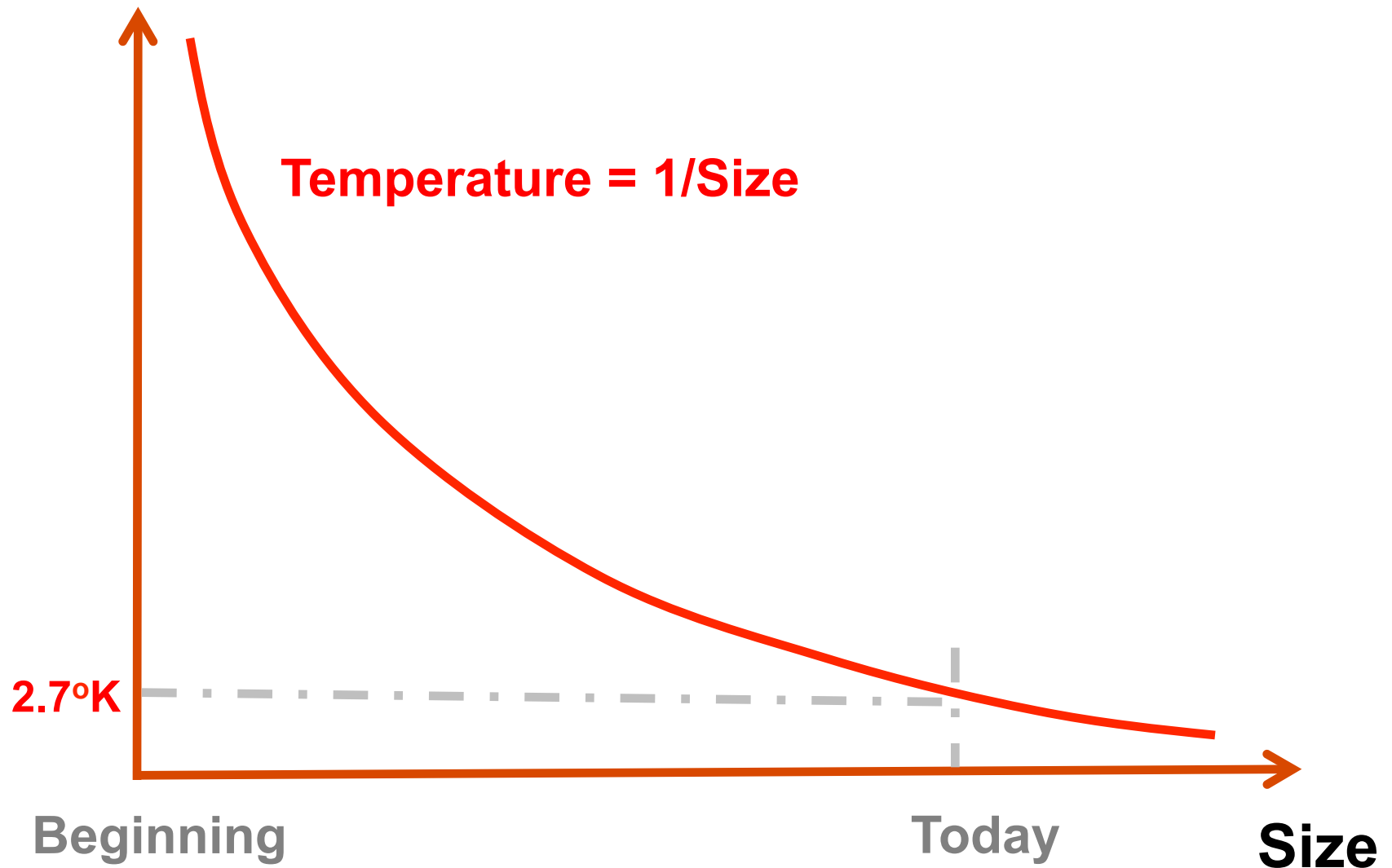

# Particle Physics

## ➤ Purpose:

- To understand the most elementary particles in nature.
- To understand the most fundamental physics laws = interaction among elementary particles.



## ➤ How?

- Study the shortest distance = The highest energy (= the highest temperature)



➤ **The best way to understand the earliest stage of the Universe**

# Periodic Table of Elements (1900)

	IA																			0		
1	1 H																				2 He	
2	3 Li	IIA	4 Be																			10 Ne
3	11 Na		12 Mg	IIIB	IVB	VB	VIB	VII B	VIII	VII	IB	IB										18 Ar
4	19 K		20 Ca	21 Sc	22 Ti	23 V	24 Cr	25 Mn	26 Fe	27 Co	28 Ni	29 Cu	30 Zn	31 Ga	32 Ge	33 As	34 Se	35 Br	36 Kr			
5	37 Rb		38 Sr	39 Y	40 Zr	41 Nb	42 Mo	43 Tc	44 Ru	45 Rh	46 Pd	47 Ag	48 Cd	49 In	50 Sn	51 Sb	52 Te	53 I	54 Xe			
6	55 Cs		56 Ba	*La	72 Hf	73 Ta	74 W	75 Re	76 Os	77 Ir	78 Pt	79 Au	80 Hg	81 Tl	82 Pb	83 Bi	84 Po	85 At	86 Rn			
7	87 Fr		88 Ra	+Ac	104 Rf	105 Ha	106	107	108	109	110											

\* Lanthanide Series

58 Ce	59 Pr	60 Nd	61 Pm	62 Sm	63 Eu	64 Gd	65 Tb	66 Dy	67 Ho	68 Er	69 Tm	70 Yb	71 Lu
----------	----------	----------	----------	----------	----------	----------	----------	----------	----------	----------	----------	----------	----------

+ Actinide Series

90 Th	91 Pa	92 U	93 Np	94 Pu	95 Am	96 Cm	97 Bk	98 Cf	99 Es	100 Fm	101 Md	102 No	103 Lr
----------	----------	---------	----------	----------	----------	----------	----------	----------	----------	-----------	-----------	-----------	-----------

H - gas

Li - solid

Br - liquid

Tc - synthetic



Non-Metals



Transition Metals



Rare Earth Metals



Halogens



Alkali Metals



Alkali Earth Metals



Other Metals



Inert Elements

# Elementary Particles (1930)

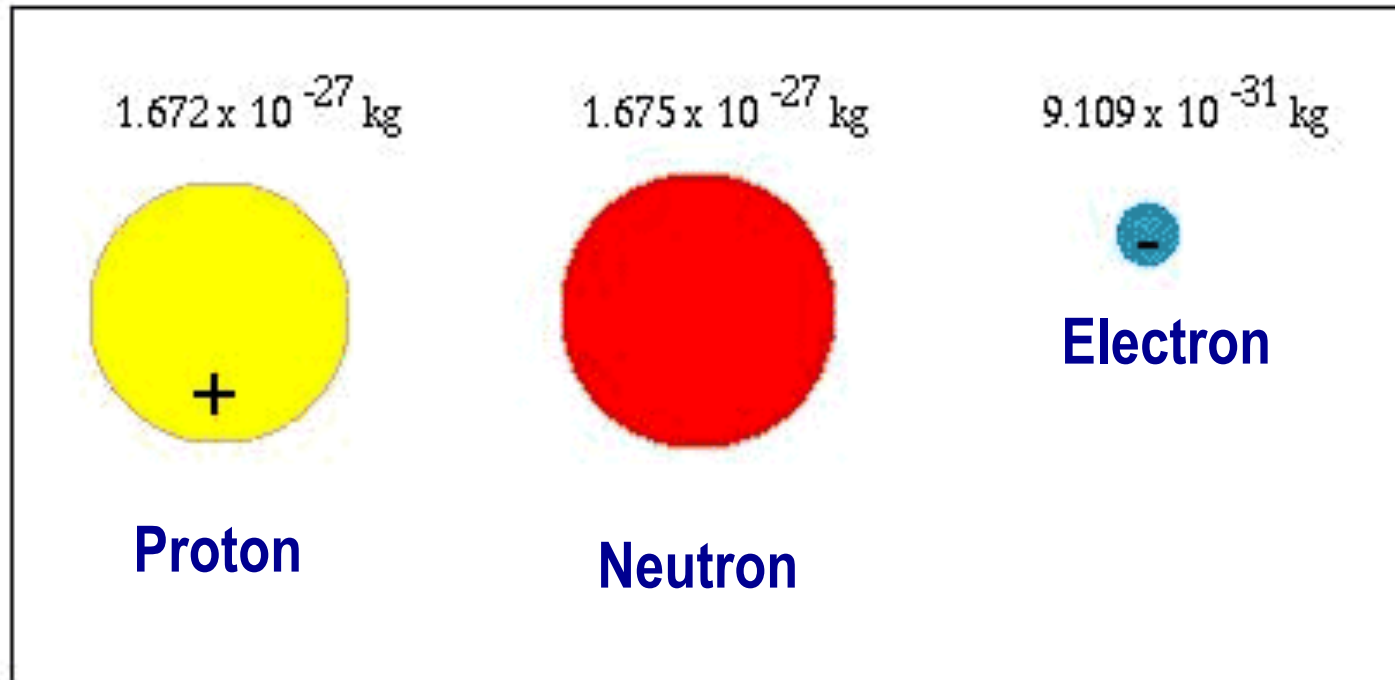

$$\text{Avogadro Number} = 1 \text{ g} / 1.762 \times 10^{-27} \text{ kg} = 6 \times 10^{23}$$

# Atoms

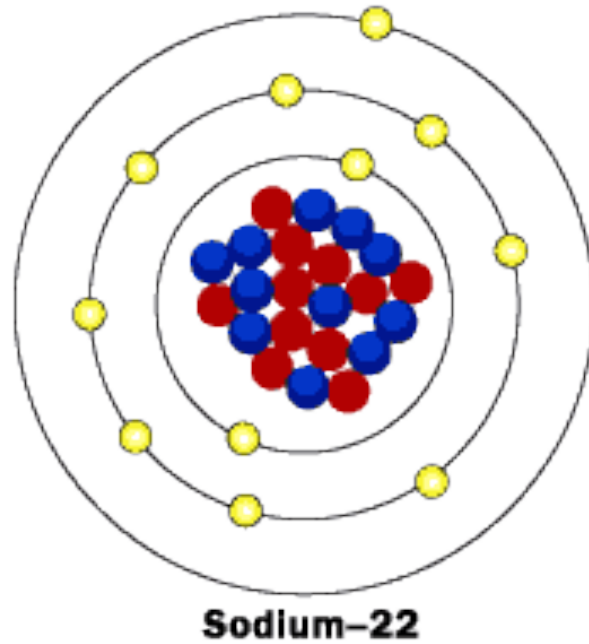
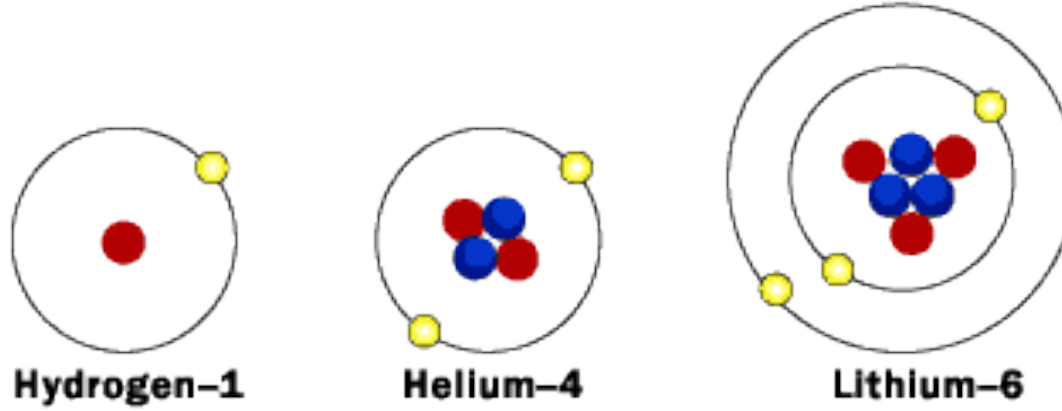

● Neutron      ● Proton      ● Electron

# SLAC (Stanford Linear Accelerator Center)

1 mile long

$e^+ + e^-$



# Fermi Lab near Chicago

6km Circumference  
 $1+1=2$  TeV

$p + p^-$



# Elementary Particles (1970)

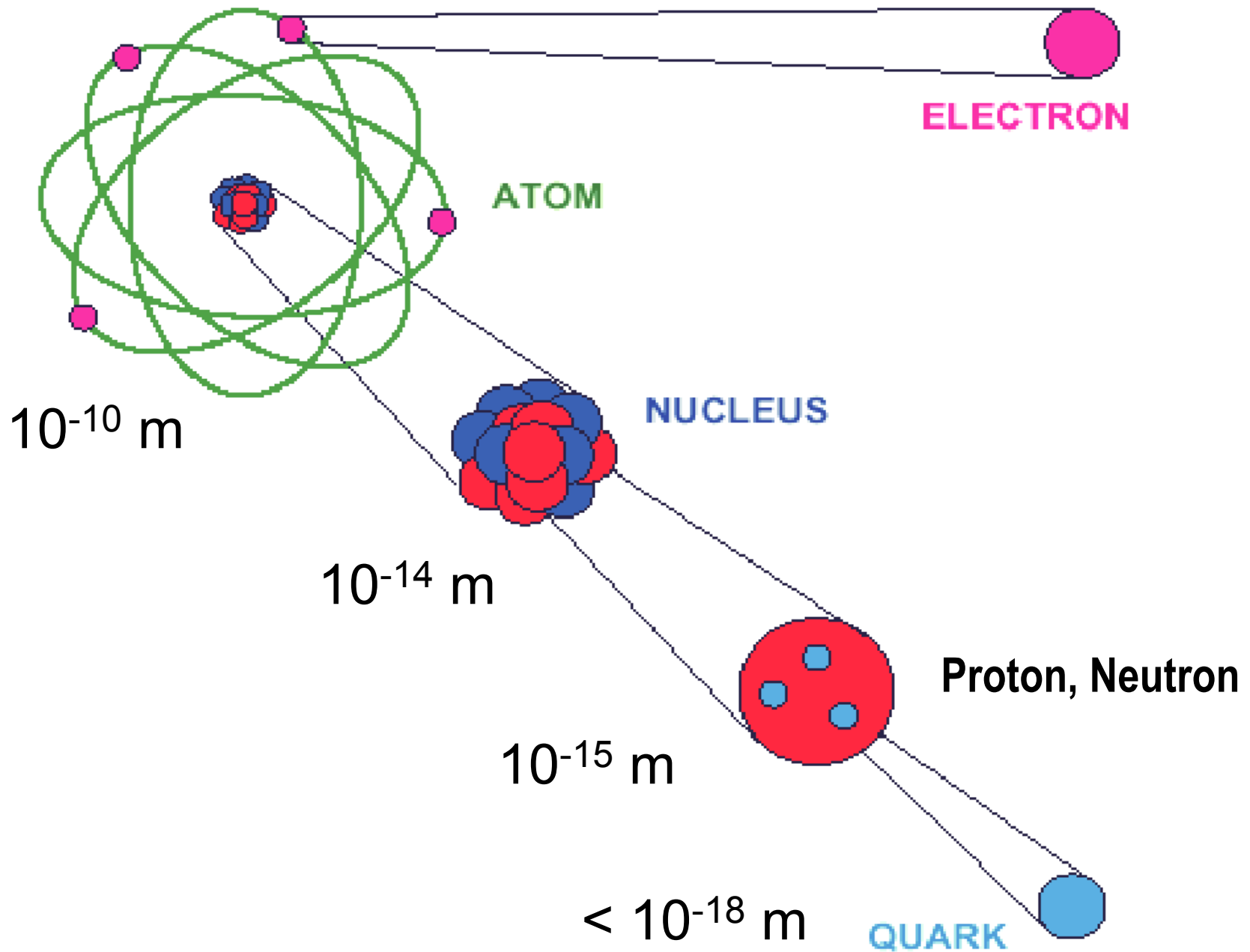

# Quark Model

**Proton**

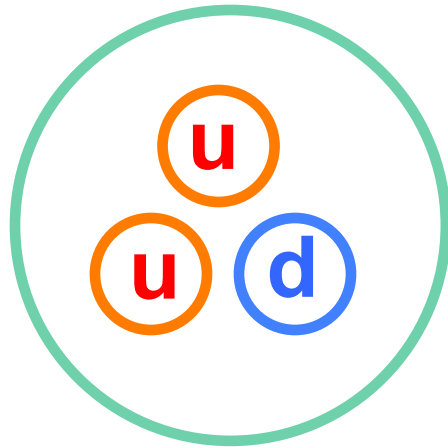

$$+ 2/3 + 2/3 - 1/3 = 1$$

**Neutron**

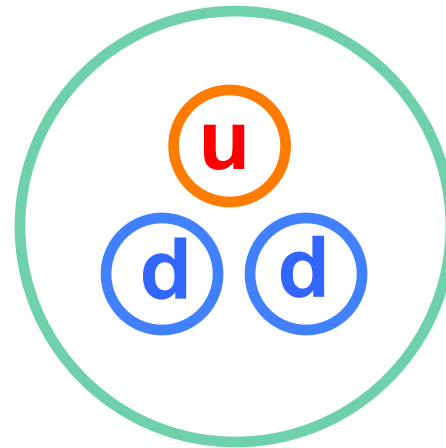

$$+ 2/3 - 1/3 - 1/3 = 0$$

# Elementary Particles (2000)

		Fermion			Boson		
Charge						Charge	
+2/3	Quarks	$u$ up	$c$ charm	$t$ top	Force Carriers	$\gamma$ photon	0
		$d$ down	$s$ strange	$b$ bottom		$g$ gluon	0
-1/3	Leptons	$\nu_e$ electron neutrino	$\nu_\mu$ muon neutrino	$\nu_\tau$ tau neutrino		$Z$ Z boson	0
		$e$ electron	$\mu$ muon	$\tau$ tau		$W$ W boson	$\pm 1$
0							
-1							
		I	II	III			
Three Families of Matter							

+ Anti-particles

# Elementary Particles and Forces

**Strong**

Gluons (8)

Quarks

Mesons  
Baryons

Nuclei

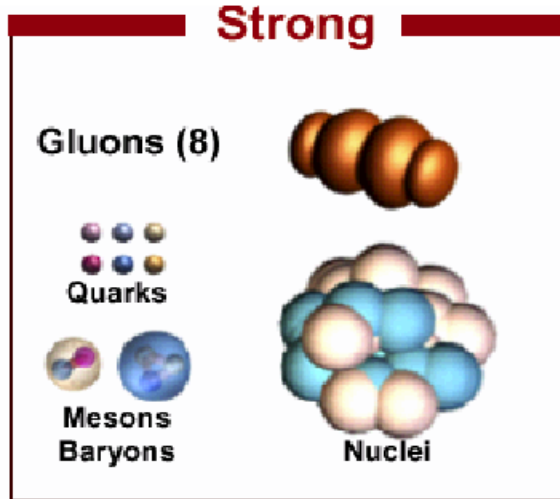
The diagram for the strong force shows various components. At the top, there are eight orange spheres representing gluons. Below them are six small colored spheres representing quarks. Further down are two pairs of quarks representing mesons and two groups of three quarks representing baryons. At the bottom is a large cluster of quarks representing a nucleus.

1

**Weak**

Bosons (W,Z)

Neutron decay  
Beta radioactivity  
Neutrino interactions  
Burning of the sun

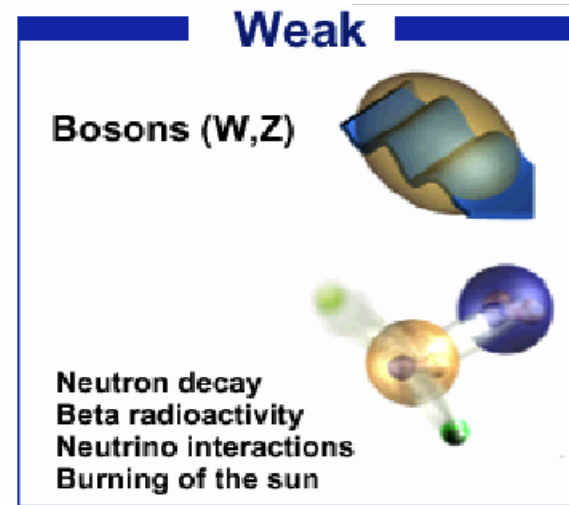
The diagram for the weak force shows two bosons (W and Z) at the top. Below them are three examples of weak interactions: a neutron decaying into a proton and an electron, a beta particle being emitted from a nucleus, and a neutrino interacting with a nucleus.

$10^{-13}$

**Electromagnetic**

Photon

Atoms  
Light  
Chemistry  
Electronics

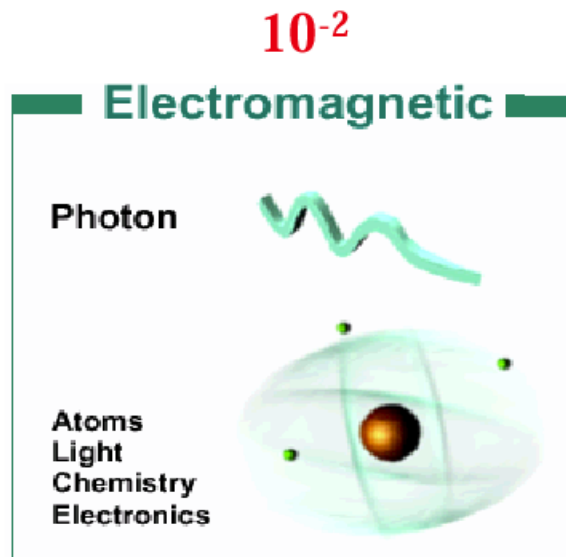
The diagram for the electromagnetic force shows a green wavy line representing a photon at the top. Below it is a model of an atom with a central nucleus and orbiting electrons.

$10^{-2}$

**Gravitational**

Graviton ?

Solar system  
Galaxies  
Black holes

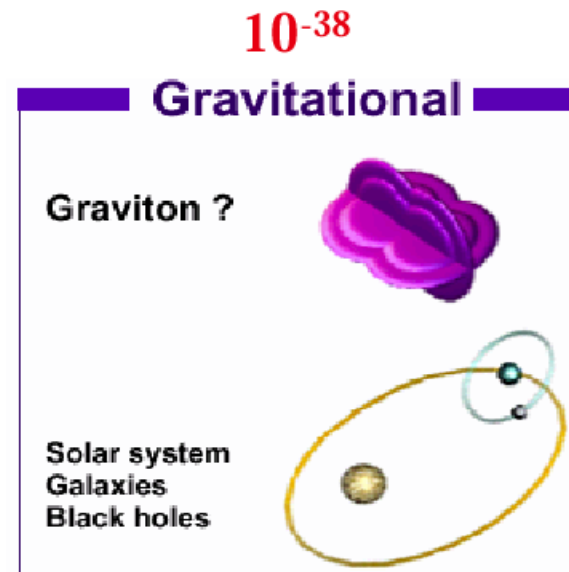
The diagram for the gravitational force shows a purple cloud-like shape representing a graviton at the top. Below it are three examples of gravitational interactions: a planet orbiting a star in a solar system, a galaxy, and a black hole.

$10^{-38}$

# Power of Electric Force

## ➤ Electric Force is responsible for

- Electrons' trajectory around a nuclei
- Molecular structure
- Structure of any life (like your body), building, bridge etc...
  - Structure of anything larger than a nuclei but smaller than the mountain.
- How your brain works
- Mechanism behind computer, TV, car etc...
- ...

# Power of Gravity

- **Gravity is responsible for**
  - Your staying on the ground
  - Trajectory of a ball
  - Orbit of Satellite, moon...
  - Formation of the solar system
  - Formation of the Galaxy
  - ...
- **Gravity is very, very weak compared to Electric Force.**
  - $N = (\text{Electric force}) / (\text{Gravity}) = 10^{39}$

# Power of Strong Force

## ➤ Strong Force is responsible for

- **Structure of the nuclei**
  - How protons and neutrons are bound together
- **Nuclear fission**
  - Nuclear power plant
  - Atomic bomb
- **Nuclear fusion**
  - Sun's energy

# The Solar Interior

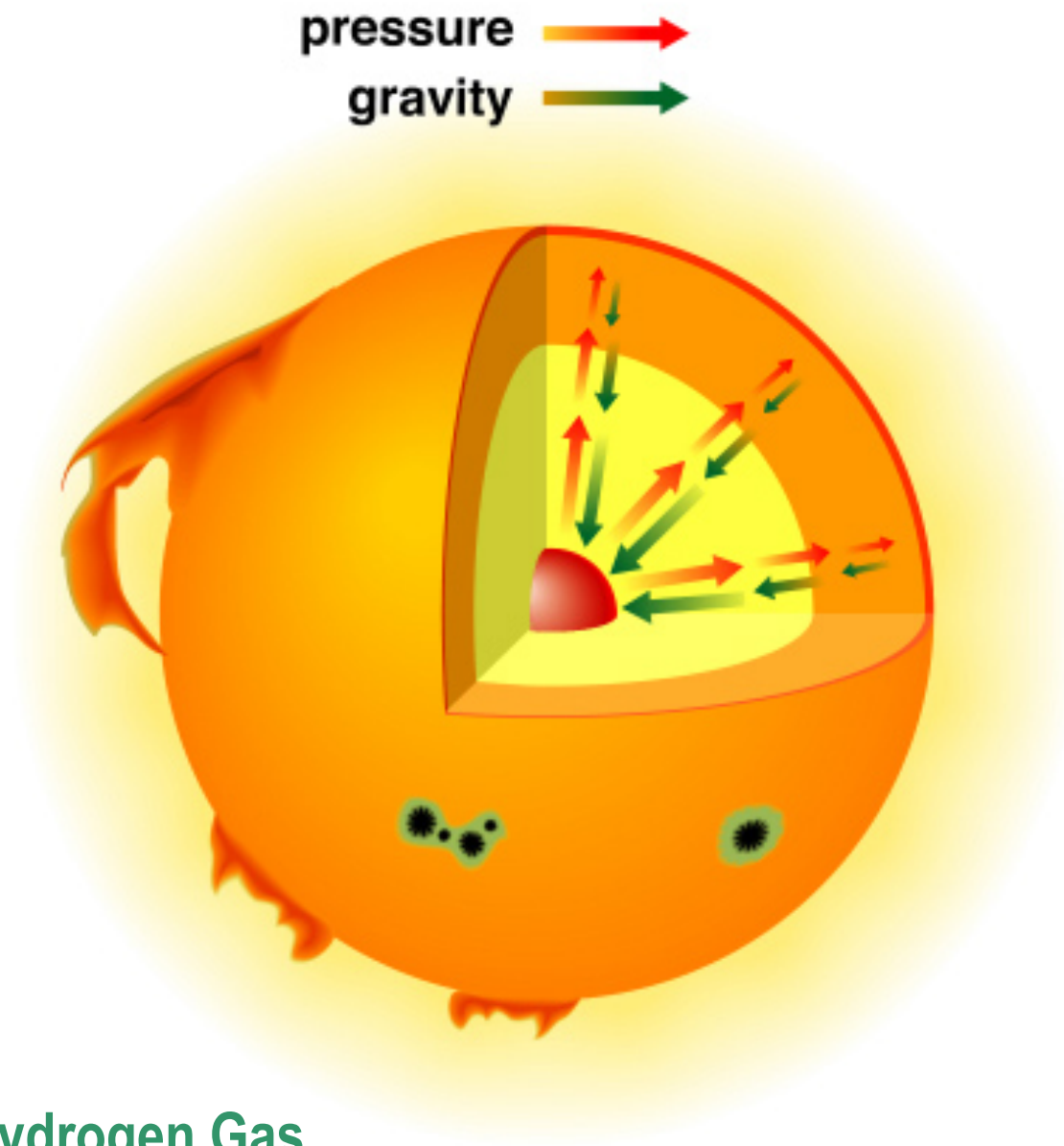

Hydrogen Gas

# Solar Energy

$$E = mc^2$$

$$m_{4p} > m_{He}$$

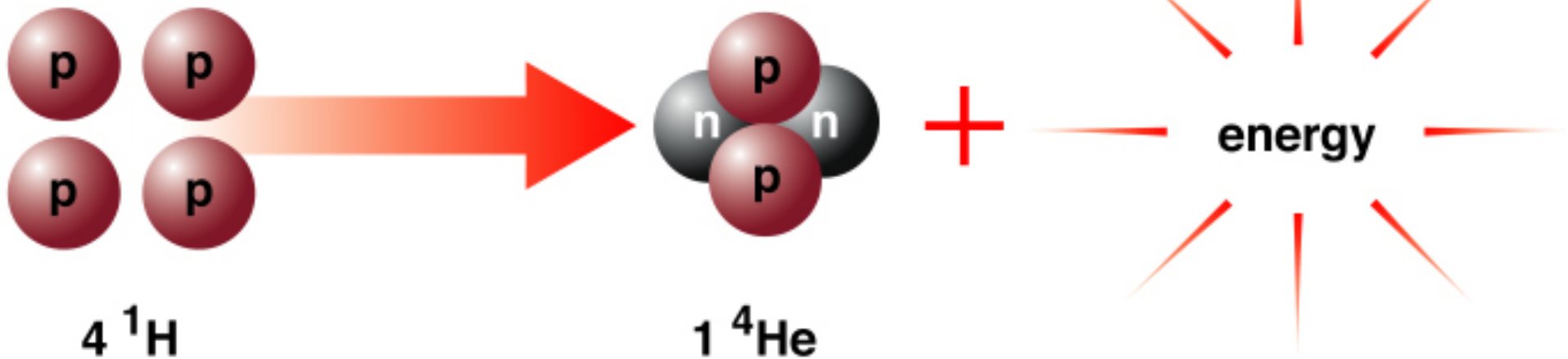

# Unification of Forces

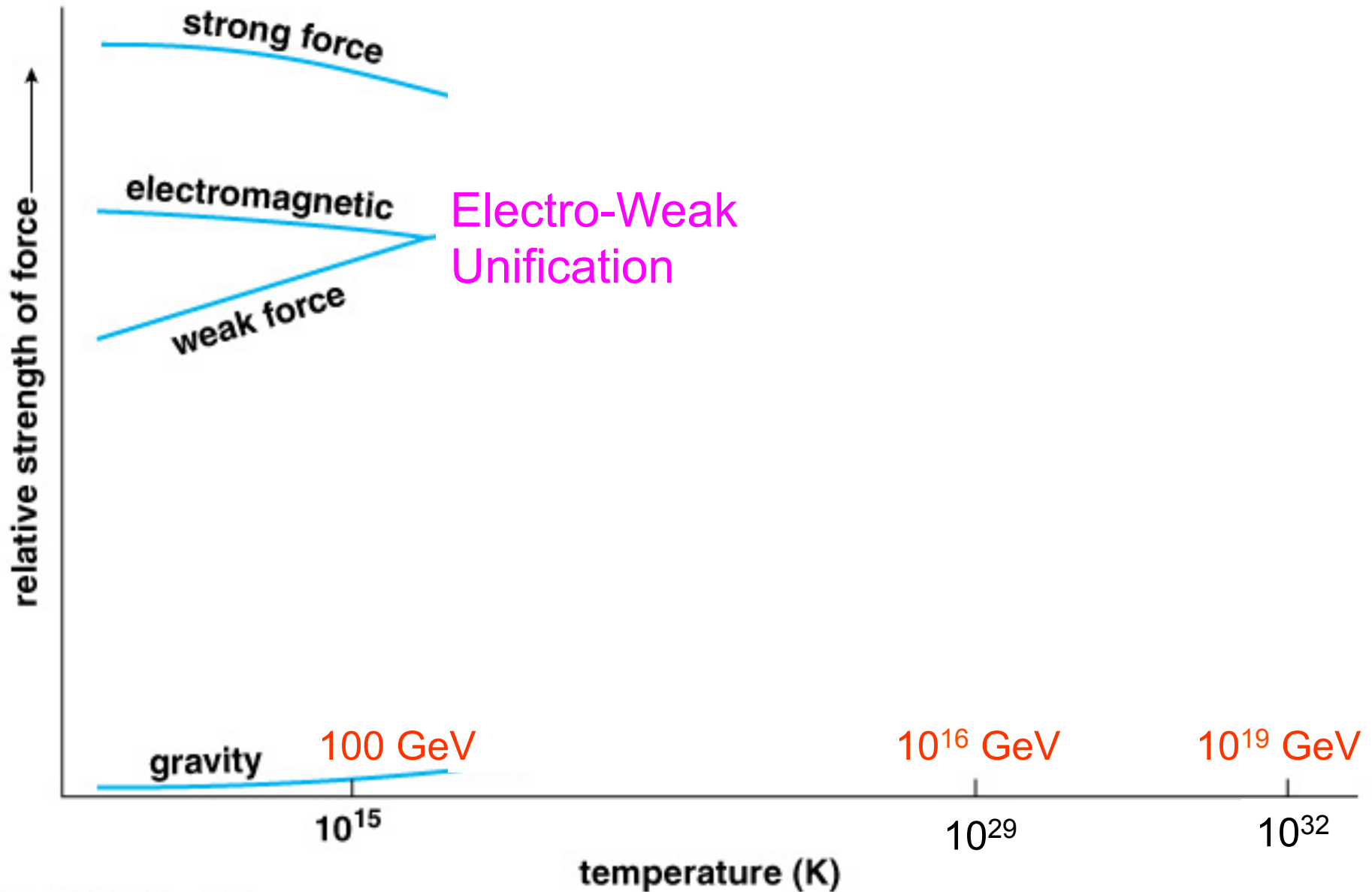

Copyright © Addison Wesley.

# Unification of Forces

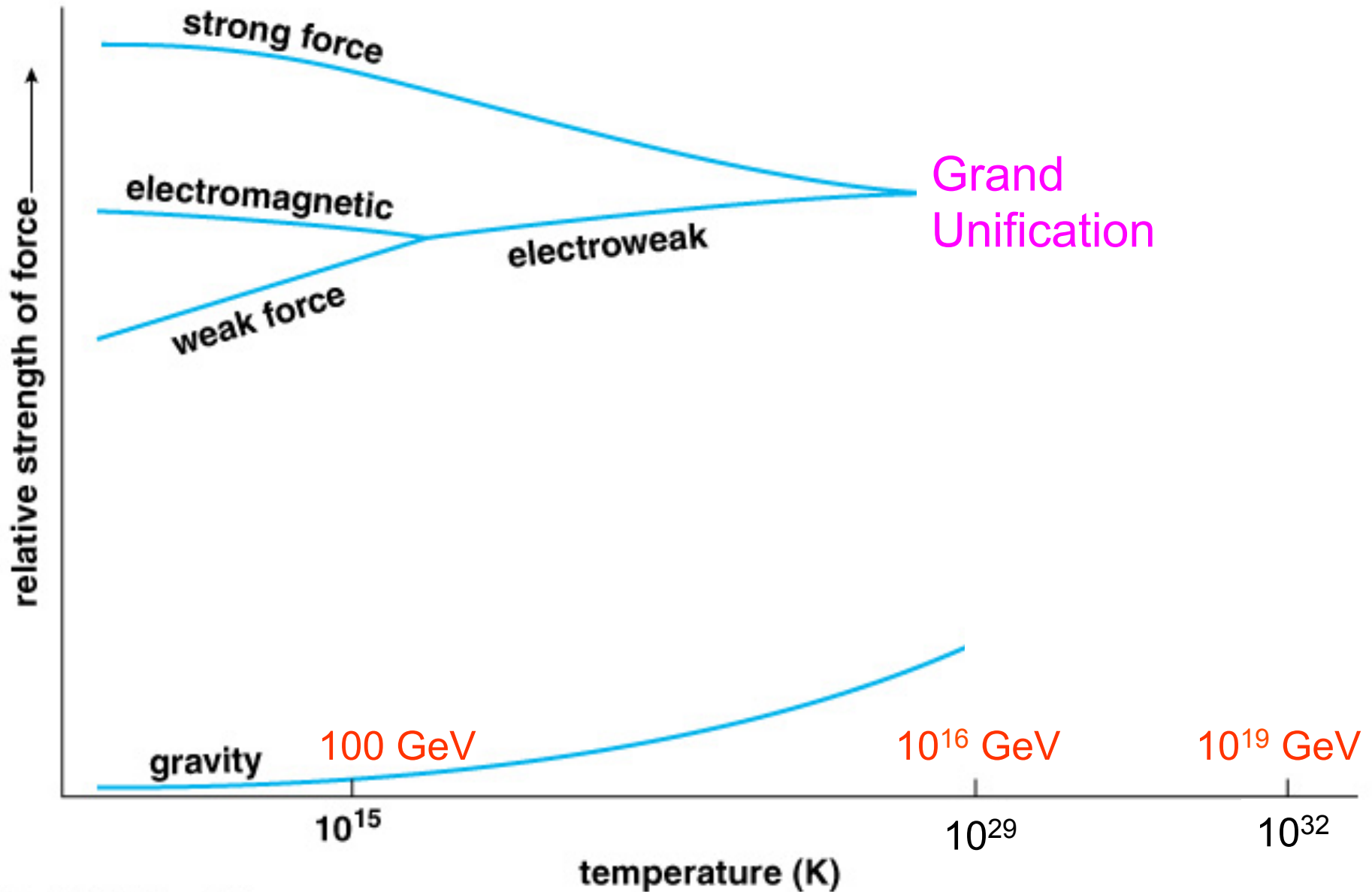

Copyright © Addison Wesley.

# Unification of Forces

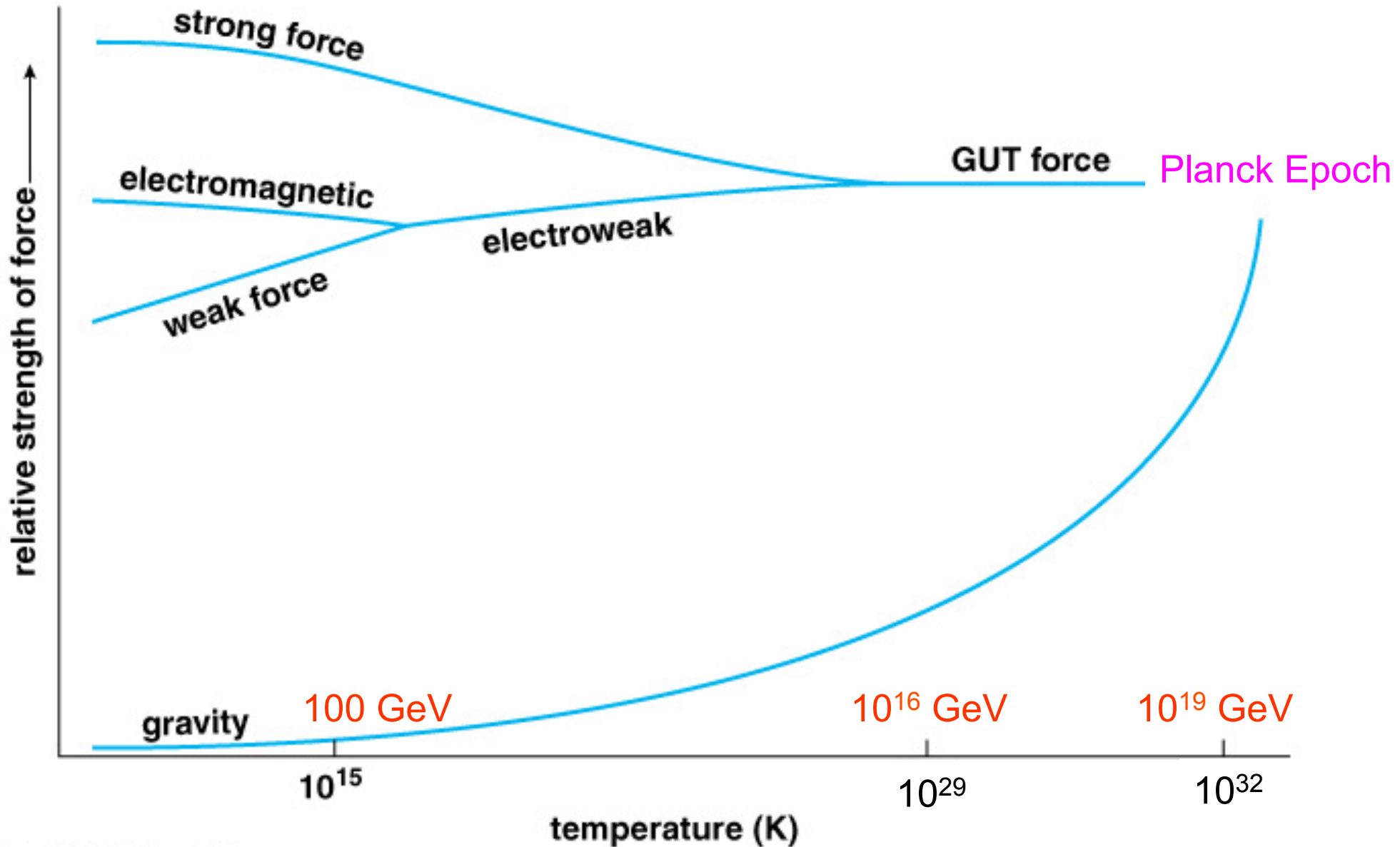

Copyright © Addison Wesley.



# Structure of DNA

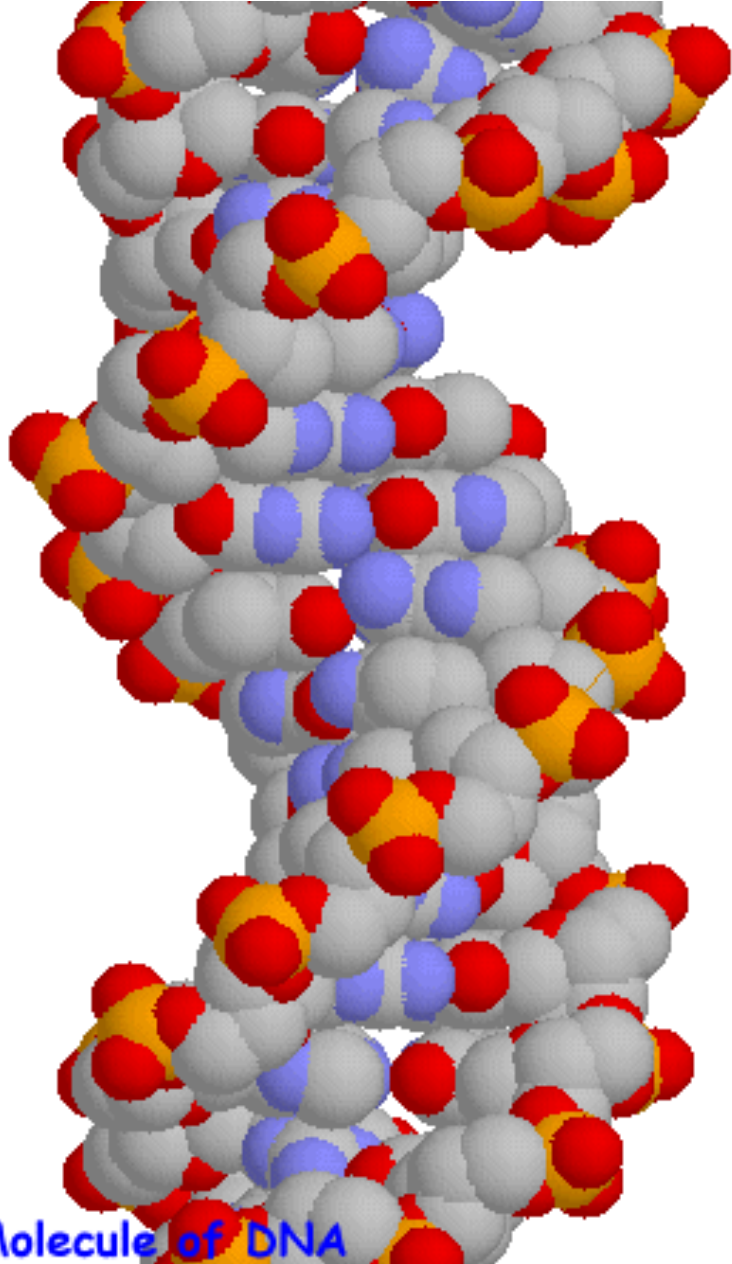

©Rothamsted Experimental Station, 1997, 1998

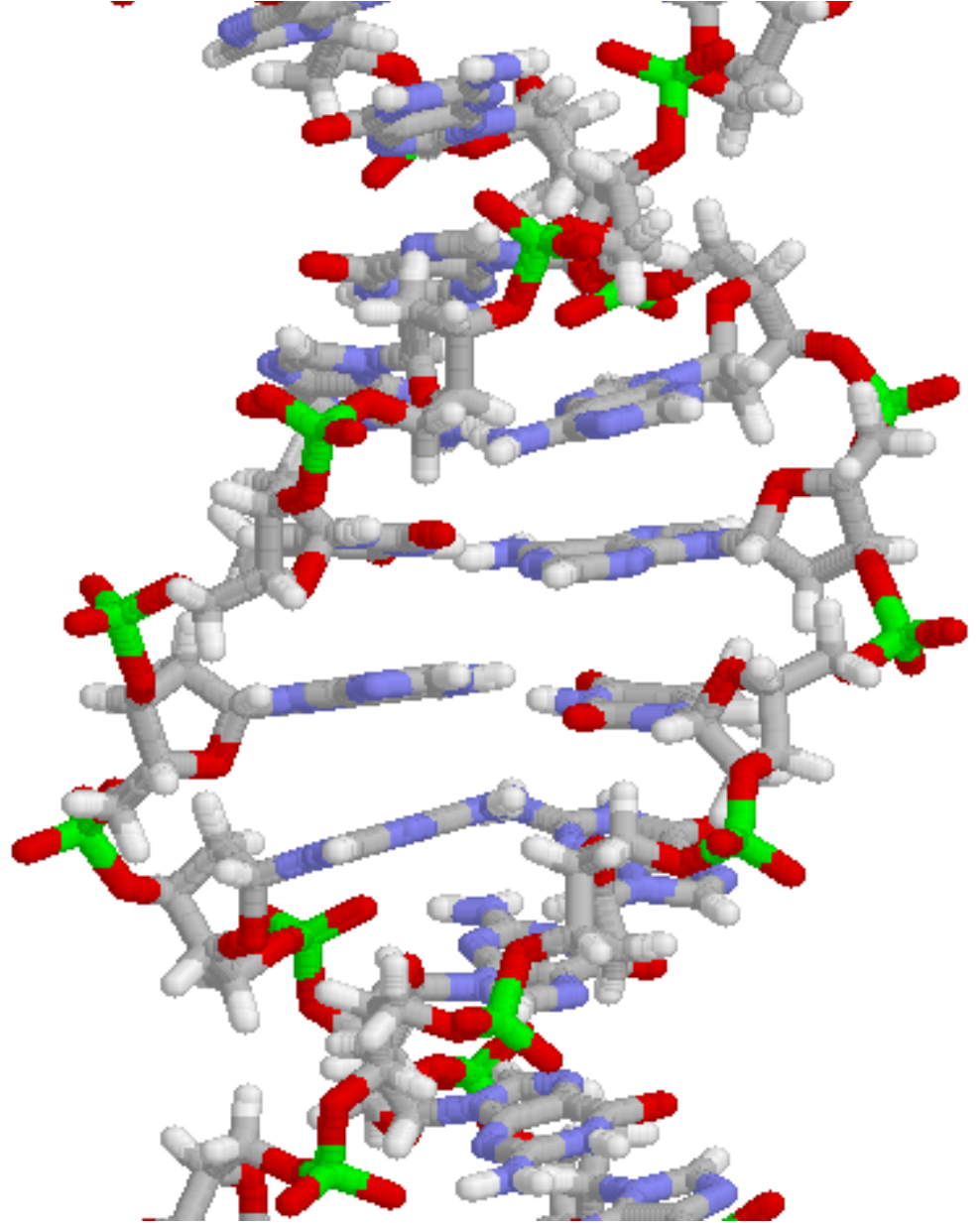

Molecule of DNA

# Symmetry Breaking

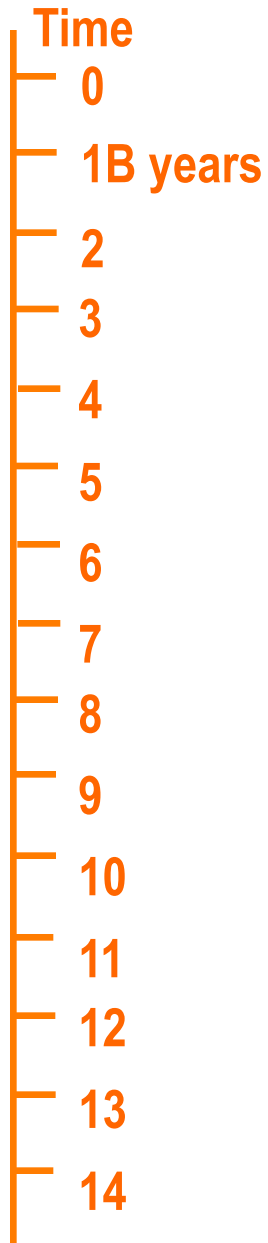

*Simple*

*Symmetry  
Break Down*

*Complex*

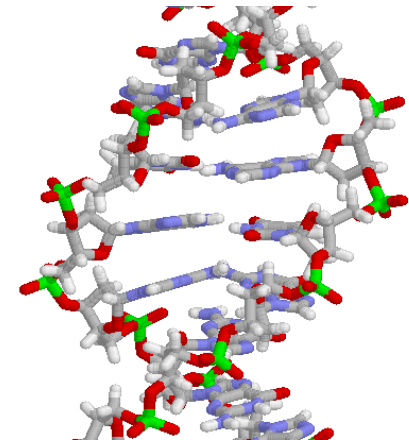
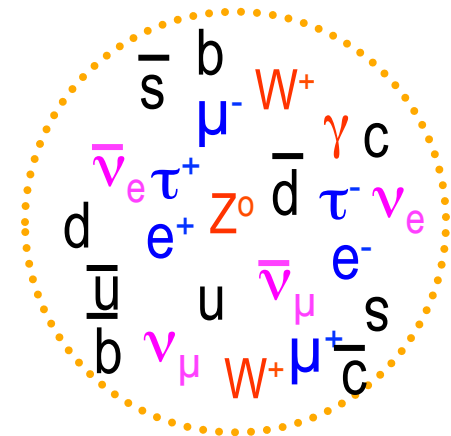

# The Beginning

- Everything was the same  $\leftrightarrow$  Perfect symmetry.
  - All the particles are the same as photons.
  - All four forces are the same.
- The Universe was 10 dimension.

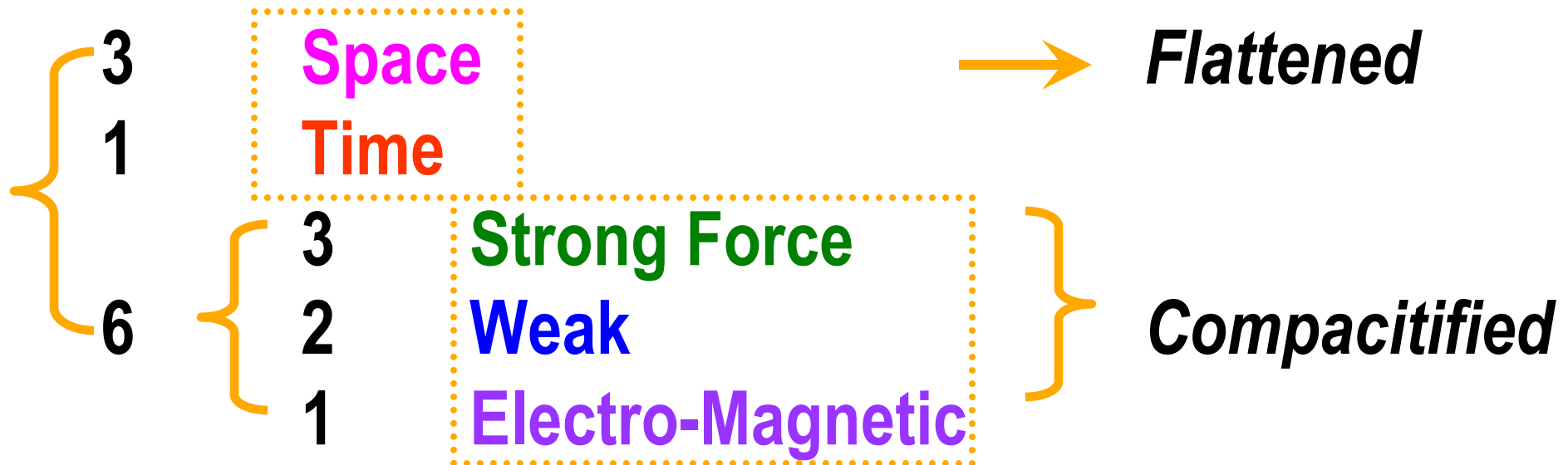

# Seven Phases of Cosmic Evolution

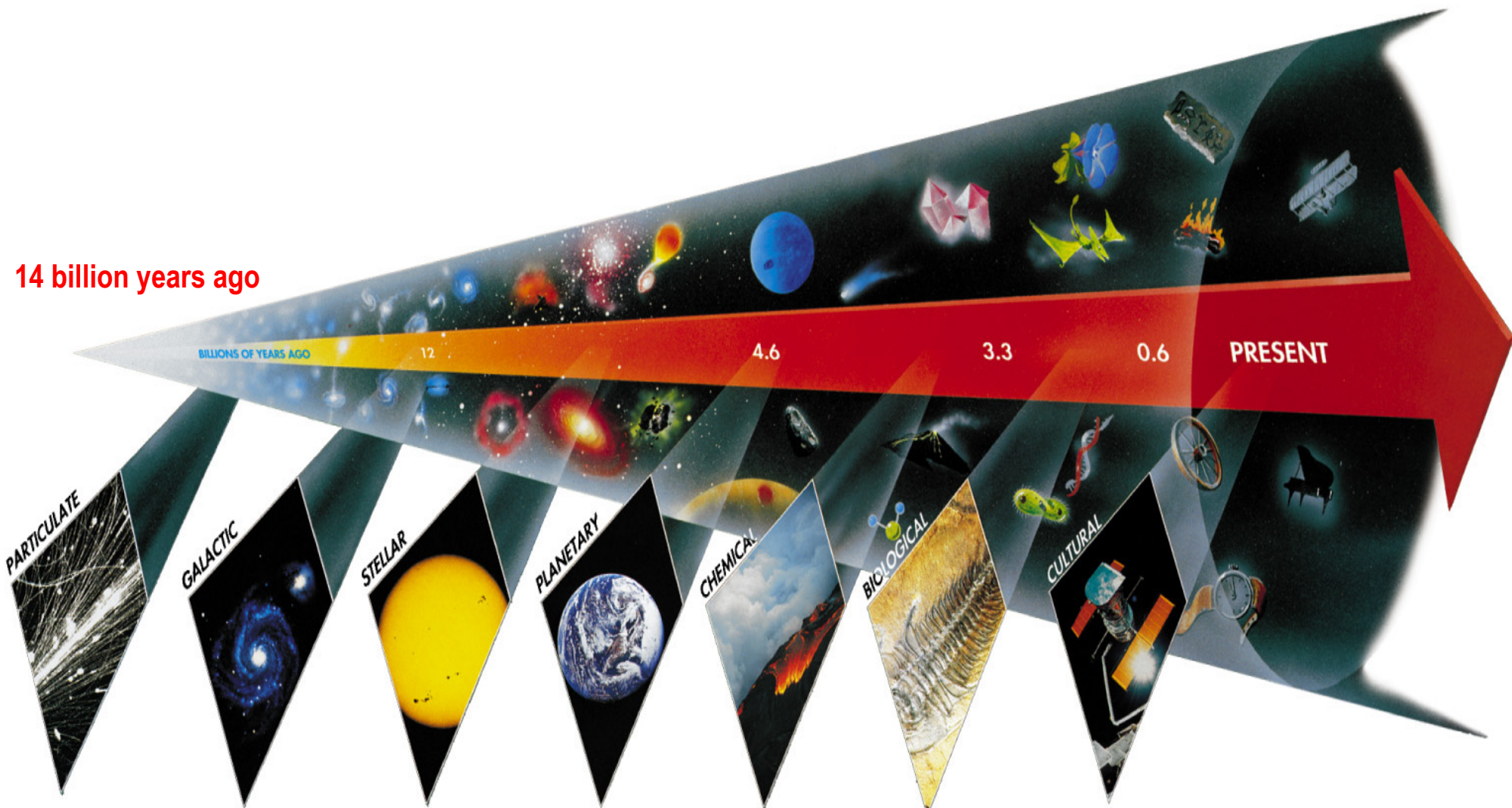

Origin of  
Particles

# CERN and LHC in Geneva

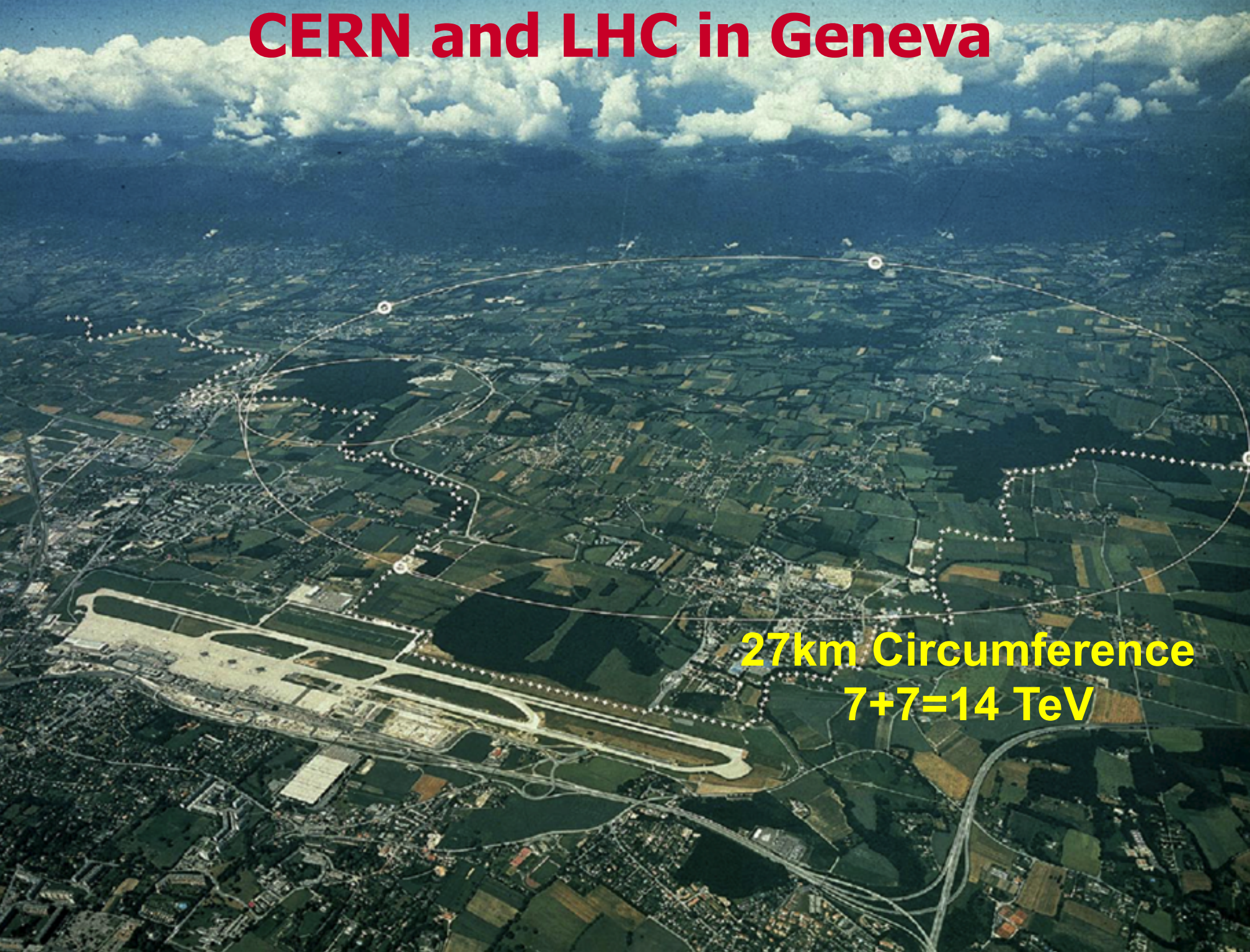

27km Circumference  
7+7=14 TeV

# Overall view of the LHC experiments.

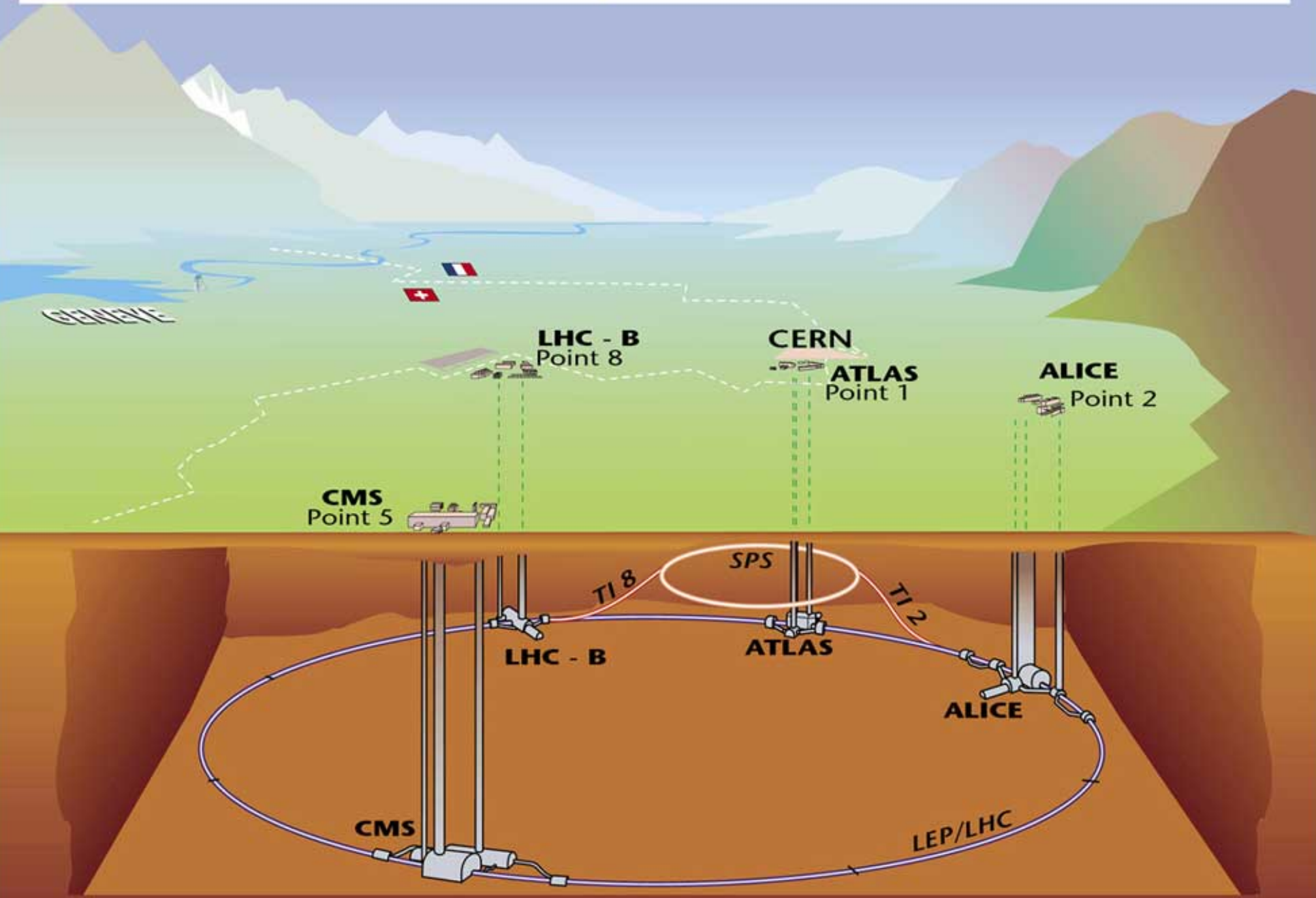

# LHC Tunnel with Magnets

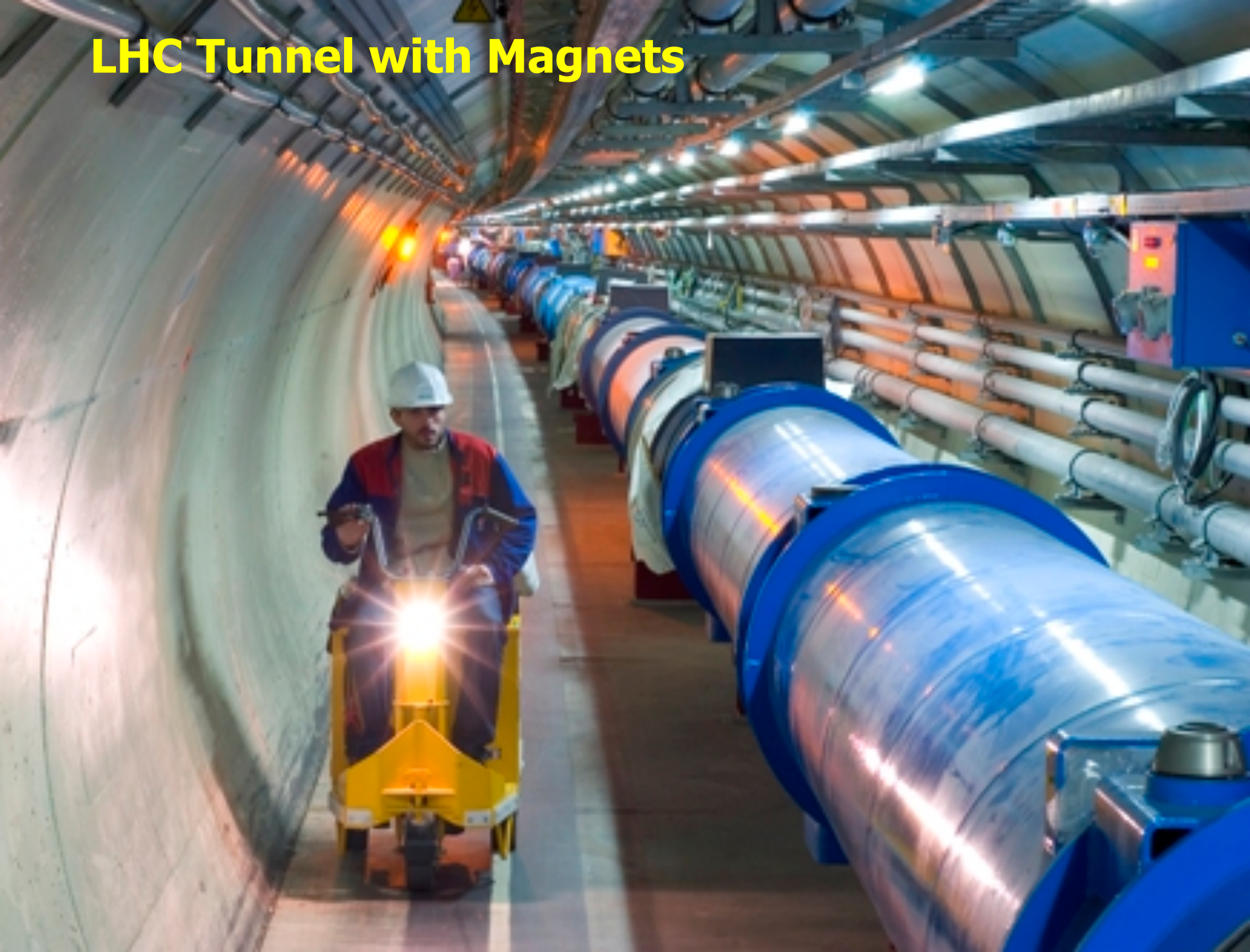

# CMS Collaboration (1993 ~)

(144 Institutions with about 1700 scientists)



## ARMENIA

- Yerevan Physics Inst., Yerevan



## AUSTRIA

- HEPHY, Wien



## BELARUS

- Institute of Nuclear Problems, Minsk
- National Centre of Part. and HEP, Minsk
- Res. Inst. of Applied Physical Probl., Minsk
- Byelorussian State Univ., Minsk



## BELGIUM

- Univ. Instelling Antwerpen, Wilrijk
- Univ. Libre de Bruxelles, Brussels
- Vrije Universiteit Brussel, Brussels
- Univ. Catholique de Louvain, Louvain-la-Neuve
- Univ. de Mons-Hainaut, Mons



## BULGARIA

- Inst. for Nucl. Res. and Nucl. Energy, Sofia
- Univ. of Sofia, Sofia



## CHINA, PR

- Inst. of High Energy Physics, Beijing
- Peking Univ., Beijing
- Univ. for Science & Tech. of China, Hefei, Anhui



## CROATIA

- Tech. Univ. of Split, Split
- Univ. of Split, Split



## CYPRUS

- Univ. of Cyprus, Nicosia



## ESTONIA

- Inst. of Chemical Phys. and Biophys., Tallinn



## FINLAND

- Helsinki Institute of Physics, Helsinki
- Dpt of Phys., Univ. of Helsinki, Helsinki
- Univ. of Jyväskylä, Jyväskylä
- Helsinki University of Technology, Helsinki
- Univ. of Oulu, Oulu
- Tampere Univ. of Tech., Tampere



## FRANCE

- LAPP, IN2P3-CNRS, Annecy-le-Vieux
- IPN, IN2P3-CNRS, Univ. Lyon I, Villeurbanne
- LPNHE, Ecole Polytech., IN2P3-CNRS, Palaiseau
- DSM/DAPNIA, CEA/Saclay, Gif-sur-Yvette
- IRES, IN2P3-CNRS - ULP, UHA, LEPSI, Strasbourg



## GEORGIA

- High Energy Phys. Inst., Tbilisi State Univ., Tbilisi
- Inst. of Physics Academy of Science, Tbilisi



## GERMANY

- RWTH, I. Physik. Inst., Aachen
- RWTH, III. Physik. Inst. A, Aachen
- RWTH, III. Physik. Inst. B, Aachen
- Humboldt-Univ. zu Berlin, Berlin
- Inst. für Exp. Kernphysik, Karlsruhe



## GREECE

- Univ. of Athens, Athens
- Inst. of Nucl. Phys. "Demokritos", Attiki
- Univ. of Ioánnina, Ioánnina



## HUNGARY

- KFKI Res. Inst. for Part. & Nucl. Phys., Budapest
- Kossuth Lajos Univ., Debrecen
- Institute of Nuclear Research ATOMKI, Debrecen



## INDIA

- Panjab Univ., Chandigarh
- Bhabha Atomic Res. Centre, Mumbai
- Univ. of Delhi South Campus, New Delhi
- TIFR - EHEP, Mumbai
- TIFR - HECR, Mumbai



## ITALY

- Univ. di Bari e Sez. dell' INFN, Bari
- Univ. di Bologna e Sez. dell' INFN, Bologna
- Univ. di Catania e Sez. dell' INFN, Catania
- Univ. di Firenze e Sez. dell' INFN, Firenze
- Univ. di Genova e Sez. dell' INFN, Genova
- Univ. di Padova e Sez. dell' INFN, Padova
- Univ. di Pavia e Sez. dell' INFN, Pavia
- Univ. di Perugia e Sez. dell' INFN, Perugia
- Univ. di Pisa e Sez. dell' INFN, Pisa
- Univ. di Roma I e Sez. dell' INFN, Roma
- Univ. di Torino e Sez. dell' INFN, Torino



## KOREA

- Cheju National University, Cheju
- Chonnam National University, Kwangju
- Choongbuk National University, Chongju
- Dongshin University, Naju
- Kangnung National University, Kangnung
- Kangwon National University, Chunchon
- Kon-Kuk University, Seoul
- Korea University, Seoul
- Kyungpook National University, Taegu
- Pohang University of Science and Technology, Pohang
- Gyeongsang National University, Jinju
- Seonam University, Namwon
- Seoul National Univ. of Education, Seoul
- Wonkwang University, Iri



## PAKISTAN

- Quaid-I-Azam Univ., Islamabad
- Ghulam Ishaq Khan Institute, Swabi



## POLAND

- Inst. of Exp. Phys., Warsaw
- Soltan Inst. for Nucl. Studies, Warsaw



## PORTUGAL

- LIP, Lisboa



## RUSSIA

- JINR, Dubna
- Inst. for Nucl. Res., Moscow
- Inst. for Theoretical and Exp. Phys., Moscow
- P.N. Lebedev Phys. Inst., Moscow
- Moscow State Univ., Moscow
- Budker Inst. for Nucl. Phys., Novosibirsk
- Inst. for High Energy Phys., Protvino
- Petersburg Nucl. Phys. Inst., Gatchina (St Petersburg)



## SLOVAK REPUBLIC

- Slovak University of Technology, Bratislava



## SPAIN

- CIEMAT, Madrid
- Univ. Autónoma de Madrid, Madrid
- Univ. de Oviedo, Oviedo
- IFCA, CSIC-Univ. de Cantabria, Santander



## SWITZERLAND

- Univ. Basel, Basel
- CERN, Geneva
- Paul Scherrer Inst., Villigen
- Inst. für Teilchenphysik, ETH, Zürich
- Univ. Zürich, Zürich



## TURKEY

- Cukurova Univ., Adana
- Middle East Technical Univ., Ankara



## UKRAINE

- Inst. of Single Crystals of Nat. Acad. of Science, Kharkov
- Kharkov Inst. of Phys. and Tech., Kharkov
- Kharkov State Univ., Kharkov



## UNITED KINGDOM

- Univ. of Bristol, Bristol
- Brunel Univ., Uxbridge
- Imperial College, Univ. of London, London
- RAL, Didcot



## USA

- Univ. of Alabama, Tuscaloosa
- Iowa State Univ., Ames
- Boston Univ., Boston
- California Inst. of Tech., Pasadena
- Carnegie Mellon Univ., Pittsburgh
- Univ. of Illinois at Chicago, Chicago
- Fairfield Univ., Fairfield
- Fermi National Accelerator Lab., Batavia
- Florida State Univ. - HEPG, Tallahassee
- Florida State Univ. - SCRI, Tallahassee
- Univ. of Florida, Gainesville
- The Univ. of Iowa, Iowa City
- Johns Hopkins Univ., Baltimore
- LLNL, Livermore
- Los Alamos Nat. Lab., Los Alamos
- Univ. of Maryland, College Park
- Univ. of Minnesota, Minneapolis
- Univ. of Mississippi, Oxford
- Massachusetts Inst. of Tech., Cambridge
- Univ. of Nebraska-Lincoln, Lincoln
- Northeastern Univ., Boston
- Northwestern Univ., Evanston
- Univ. of Notre Dame, Notre Dame
- The Ohio State Univ., Columbus
- Princeton Univ., Princeton
- Purdue Univ., West Lafayette
- Rice Univ., Houston
- Univ. of California, Riverside
- Univ. of Rochester, Rochester
- Rutgers, the State Univ. of New Jersey, Piscataway
- Texas Tech Univ., Lubbock
- Univ. of Texas at Dallas, Richardson
- Univ. of California at Davis, Davis
- UCLA, Los Angeles
- Univ. of California San Diego, La Jolla
- Virginia Polytech. Inst. and State Univ., Blacksburg
- Univ. of Wisconsin, Madison



## UZBEKISTAN

- Inst. of Nucl. Phys. of the Uzbekistan Acad. of Sciences, Tashkent

electromagnetic calorimeter

solenoid

muon chambers

hadronic calorimeter

inner tracker

magnet yoke

CMS

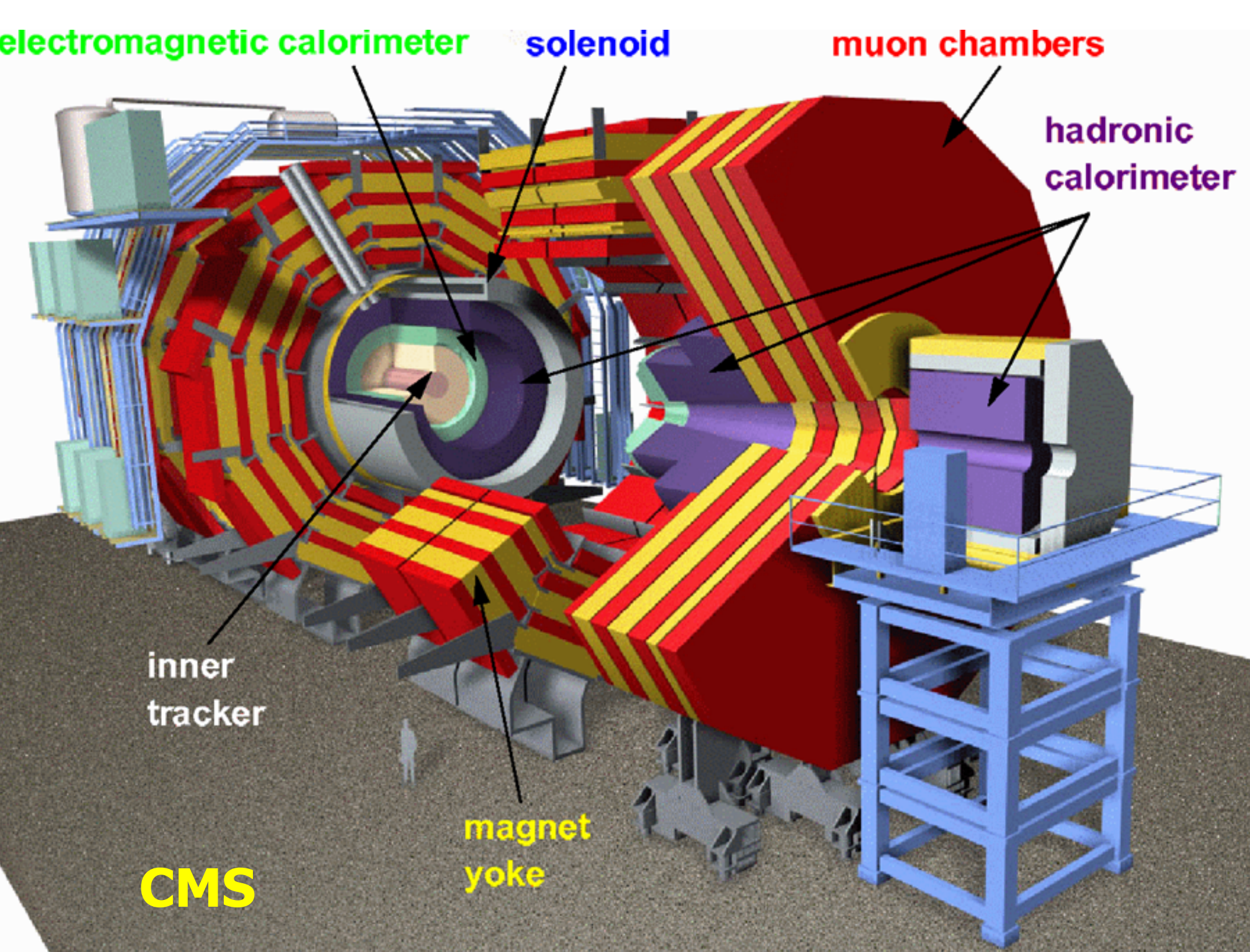

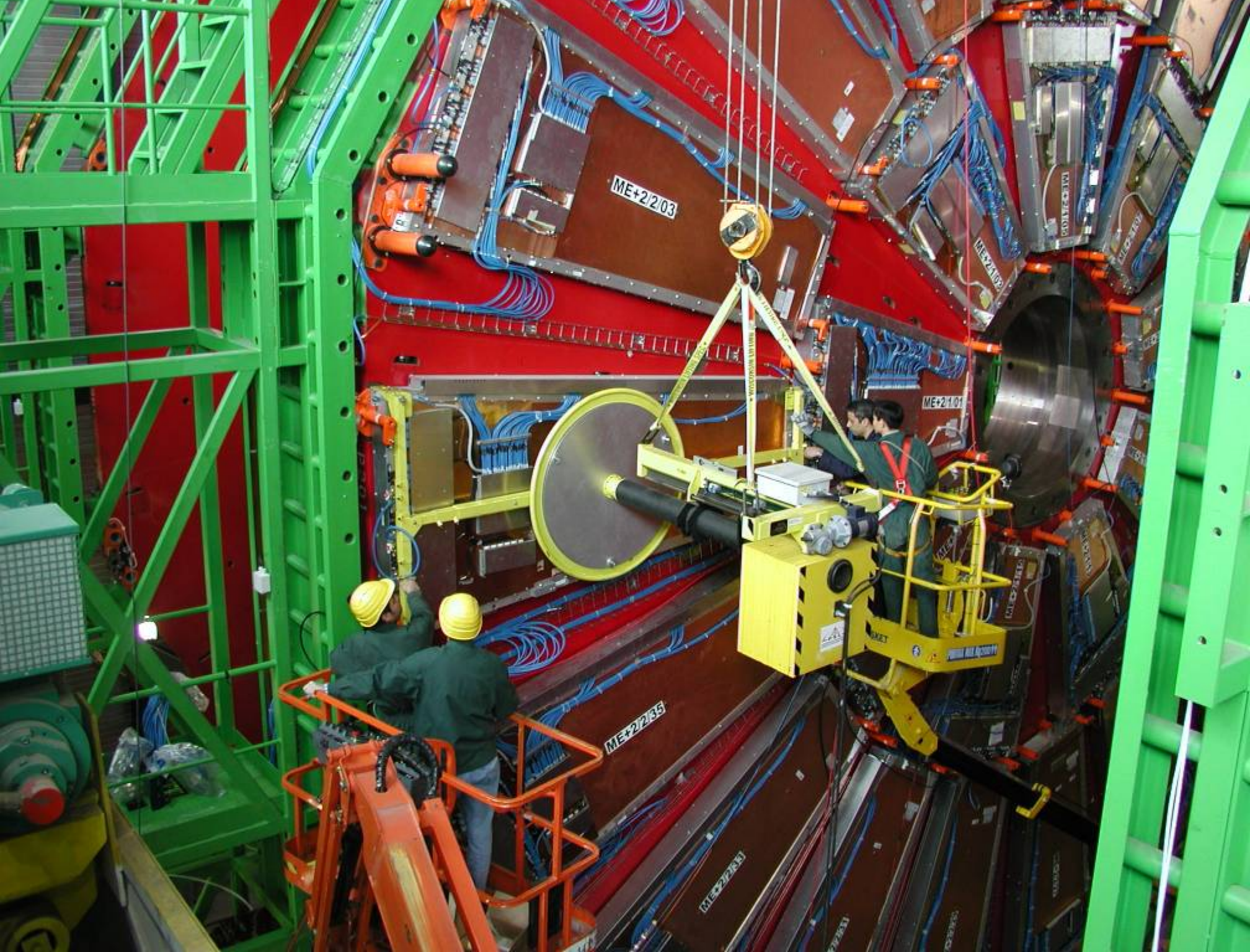







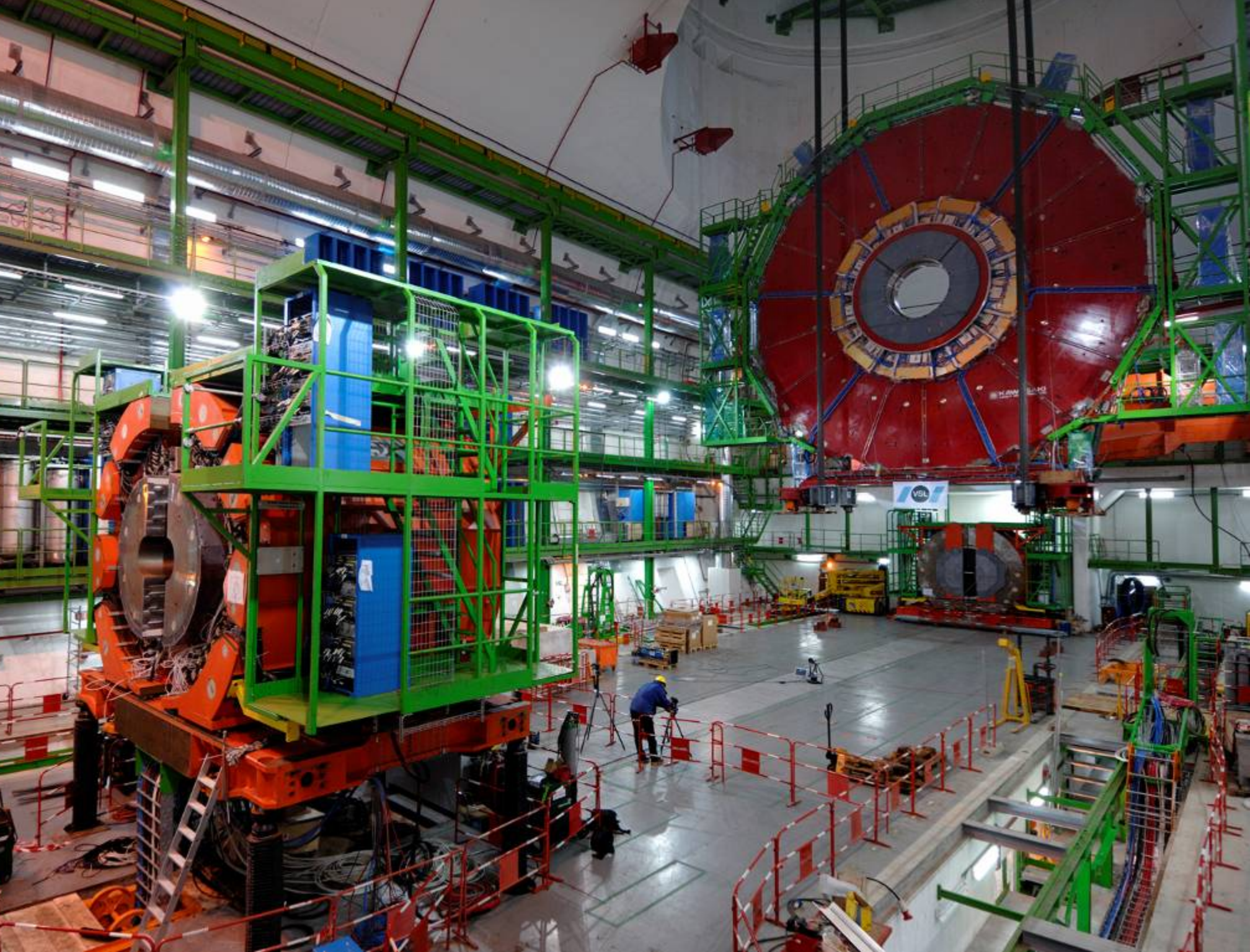

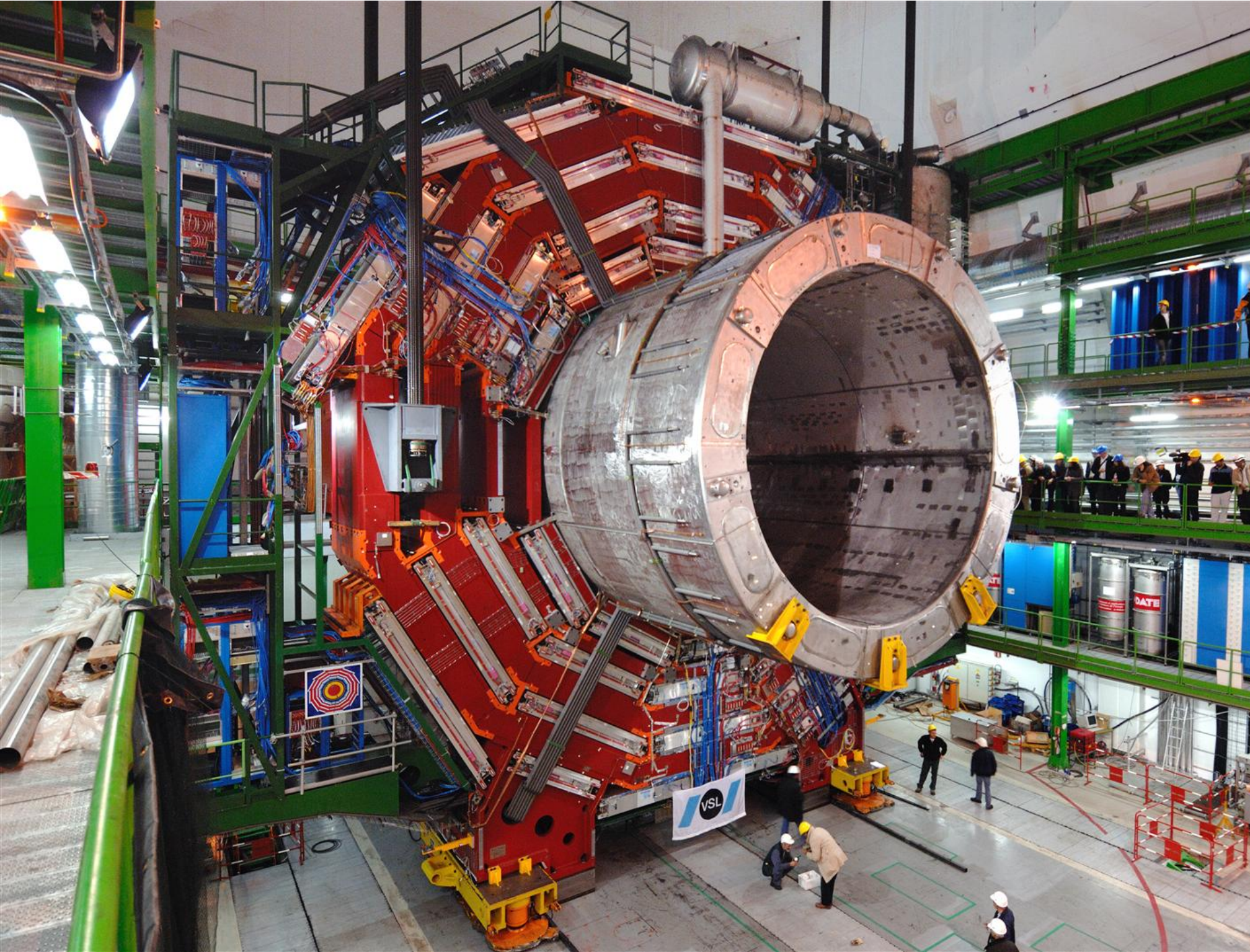

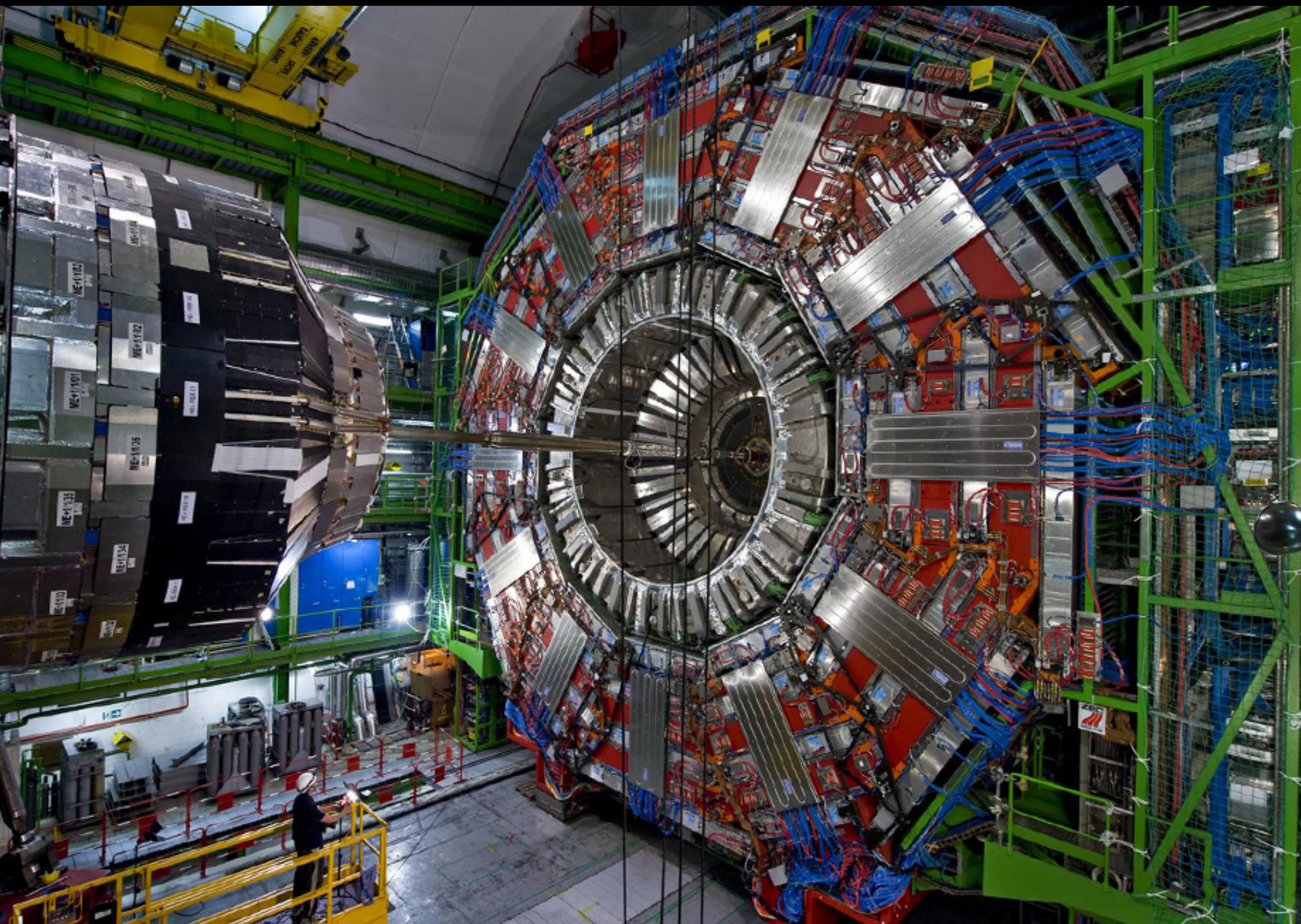

1/29/2011

Katsushi Arisaka

48

CMS Experiment, CERN

Data\_taken 2009-Nov-07 19:12:36.880368 GMT

Run\_no 120015

Event\_no 8

Lumi\_sec 1

Orbit 584946

Crossing 2603

<http://iguana.cern.ch/iss/>

L1 Triggers:

-----  
L1\_DoubleHEBitCountsRing1\_P1N1

L1\_DoubleHEBitCountsRing2\_P1N1

L1\_ETM20

L1\_ETM30

L1\_MinBias\_HTT10

L1\_Mu3QE8\_Jet6

L1\_SingleEG1

L1\_SingleEG10

L1\_SingleEG12

L1\_SingleEG15

L1\_SingleEG20

L1\_SingleEG25

L1\_SingleEG30

L1\_SingleEG35

L1\_SingleEG40

L1\_SingleEG45

L1\_SingleEG50

L1\_SingleEG55

L1\_SingleEG60

L1\_SingleEG65

L1\_SingleEG70

L1\_SingleEG75

L1\_SingleEG80

L1\_SingleEG85

L1\_SingleEG90

L1\_SingleEG95

L1\_SingleEG100

L1\_SingleEG105

L1\_SingleEG110

L1\_SingleEG115

L1\_SingleEG120

L1\_SingleEG125

L1\_SingleEG130

L1\_SingleEG135

L1\_SingleEG140

L1\_SingleEG145

L1\_SingleEG150

L1\_SingleEG155

L1\_SingleEG160

L1\_SingleEG165

L1\_SingleEG170

L1\_SingleEG175

L1\_SingleEG180

L1\_SingleEG185

L1\_SingleEG190

L1\_SingleEG195

L1\_SingleEG200

L1\_SingleEG205

L1\_SingleEG210

L1\_SingleEG215

L1\_SingleEG220

L1\_SingleEG225

L1\_SingleEG230

L1\_SingleEG235

L1\_SingleEG240

L1\_SingleEG245

L1\_SingleEG250

L1\_SingleEG255

L1\_SingleEG260

L1\_SingleEG265

L1\_SingleEG270

L1\_SingleEG275

L1\_SingleEG280

L1\_SingleEG285

L1\_SingleEG290

L1\_SingleEG295

L1\_SingleEG300

L1\_SingleEG305

L1\_SingleEG310

L1\_SingleEG315

L1\_SingleEG320

L1\_SingleEG325

L1\_SingleEG330

L1\_SingleEG335

L1\_SingleEG340

L1\_SingleEG345

L1\_SingleEG350

L1\_SingleEG355

L1\_SingleEG360

L1\_SingleEG365

L1\_SingleEG370

L1\_SingleEG375

L1\_SingleEG380

L1\_SingleEG385

L1\_SingleEG390

L1\_SingleEG395

L1\_SingleEG400

L1\_SingleEG405

L1\_SingleEG410

L1\_SingleEG415

L1\_SingleEG420

L1\_SingleEG425

L1\_SingleEG430

L1\_SingleEG435

L1\_SingleEG440

L1\_SingleEG445

L1\_SingleEG450

L1\_SingleEG455

L1\_SingleEG460

L1\_SingleEG465

L1\_SingleEG470

L1\_SingleEG475

L1\_SingleEG480

L1\_SingleEG485

L1\_SingleEG490

L1\_SingleEG495

L1\_SingleEG500

L1\_SingleEG505

L1\_SingleEG510

L1\_SingleEG515

L1\_SingleEG520

L1\_SingleEG525

L1\_SingleEG530

L1\_SingleEG535

L1\_SingleEG540

L1\_SingleEG545

L1\_SingleEG550

L1\_SingleEG555

L1\_SingleEG560

L1\_SingleEG565

L1\_SingleEG570

L1\_SingleEG575

L1\_SingleEG580

L1\_SingleEG585

L1\_SingleEG590

L1\_SingleEG595

L1\_SingleEG600

L1\_SingleEG605

L1\_SingleEG610

L1\_SingleEG615

L1\_SingleEG620

L1\_SingleEG625

L1\_SingleEG630

L1\_SingleEG635

L1\_SingleEG640

L1\_SingleEG645

L1\_SingleEG650

L1\_SingleEG655

L1\_SingleEG660

L1\_SingleEG665

L1\_SingleEG670

L1\_SingleEG675

L1\_SingleEG680

L1\_SingleEG685

L1\_SingleEG690

L1\_SingleEG695

L1\_SingleEG700

L1\_SingleEG705

L1\_SingleEG710

L1\_SingleEG715

L1\_SingleEG720

L1\_SingleEG725

L1\_SingleEG730

L1\_SingleEG735

L1\_SingleEG740

L1\_SingleEG745

L1\_SingleEG750

L1\_SingleEG755

L1\_SingleEG760

L1\_SingleEG765

L1\_SingleEG770

L1\_SingleEG775

L1\_SingleEG780

L1\_SingleEG785

L1\_SingleEG790

L1\_SingleEG795

L1\_SingleEG800

L1\_SingleEG805

L1\_SingleEG810

L1\_SingleEG815

L1\_SingleEG820

L1\_SingleEG825

L1\_SingleEG830

L1\_SingleEG835

L1\_SingleEG840

L1\_SingleEG845

L1\_SingleEG850

L1\_SingleEG855

L1\_SingleEG860

L1\_SingleEG865

L1\_SingleEG870

L1\_SingleEG875

L1\_SingleEG880

L1\_SingleEG885

L1\_SingleEG890

L1\_SingleEG895

L1\_SingleEG900

L1\_SingleEG905

L1\_SingleEG910

L1\_SingleEG915

L1\_SingleEG920

L1\_SingleEG925

L1\_SingleEG930

L1\_SingleEG935

L1\_SingleEG940

L1\_SingleEG945

L1\_SingleEG950

L1\_SingleEG955

L1\_SingleEG960

L1\_SingleEG965

L1\_SingleEG970

L1\_SingleEG975

L1\_SingleEG980

L1\_SingleEG985

L1\_SingleEG990

L1\_SingleEG995

L1\_SingleEG1000

L1\_SingleEG1005

L1\_SingleEG1010

L1\_SingleEG1015

L1\_SingleEG1020

L1\_SingleEG1025

L1\_SingleEG1030

L1\_SingleEG1035

L1\_SingleEG1040

L1\_SingleEG1045

L1\_SingleEG1050

L1\_SingleEG1055

L1\_SingleEG1060

L1\_SingleEG1065

L1\_SingleEG1070

L1\_SingleEG1075

L1\_SingleEG1080

L1\_SingleEG1085

L1\_SingleEG1090

L1\_SingleEG1095

L1\_SingleEG1100

L1\_SingleEG1105

L1\_SingleEG1110

L1\_SingleEG1115

L1\_SingleEG1120

L1\_SingleEG1125

L1\_SingleEG1130

L1\_SingleEG1135

L1\_SingleEG1140

L1\_SingleEG1145

L1\_SingleEG1150

L1\_SingleEG1155

L1\_SingleEG1160

L1\_SingleEG1165

L1\_SingleEG1170

L1\_SingleEG1175

L1\_SingleEG1180

L1\_SingleEG1185

L1\_SingleEG1190

L1\_SingleEG1195

L1\_SingleEG1200

L1\_SingleEG1205

L1\_SingleEG1210

L1\_SingleEG1215

L1\_SingleEG1220

L1\_SingleEG1225

L1\_SingleEG1230

L1\_SingleEG1235

L1\_SingleEG1240

L1\_SingleEG1245

L1\_SingleEG1250

L1\_SingleEG1255

L1\_SingleEG1260

L1\_SingleEG1265

L1\_SingleEG1270

L1\_SingleEG1275

L1\_SingleEG1280

L1\_SingleEG1285

L1\_SingleEG1290

L1\_SingleEG1295

L1\_SingleEG1300

L1\_SingleEG1305

L1\_SingleEG1310

L1\_SingleEG1315

L1\_SingleEG1320

L1\_SingleEG1325

L1\_SingleEG1330

L1\_SingleEG1335

L1\_SingleEG1340

L1\_SingleEG1345

L1\_SingleEG1350

L1\_SingleEG1355

L1\_SingleEG1360

L1\_SingleEG1365

L1\_SingleEG1370

L1\_SingleEG1375

L1\_SingleEG1380

L1\_SingleEG1385

L1\_SingleEG1390

L1\_SingleEG1395

</

# Seven Phases of Cosmic Evolution

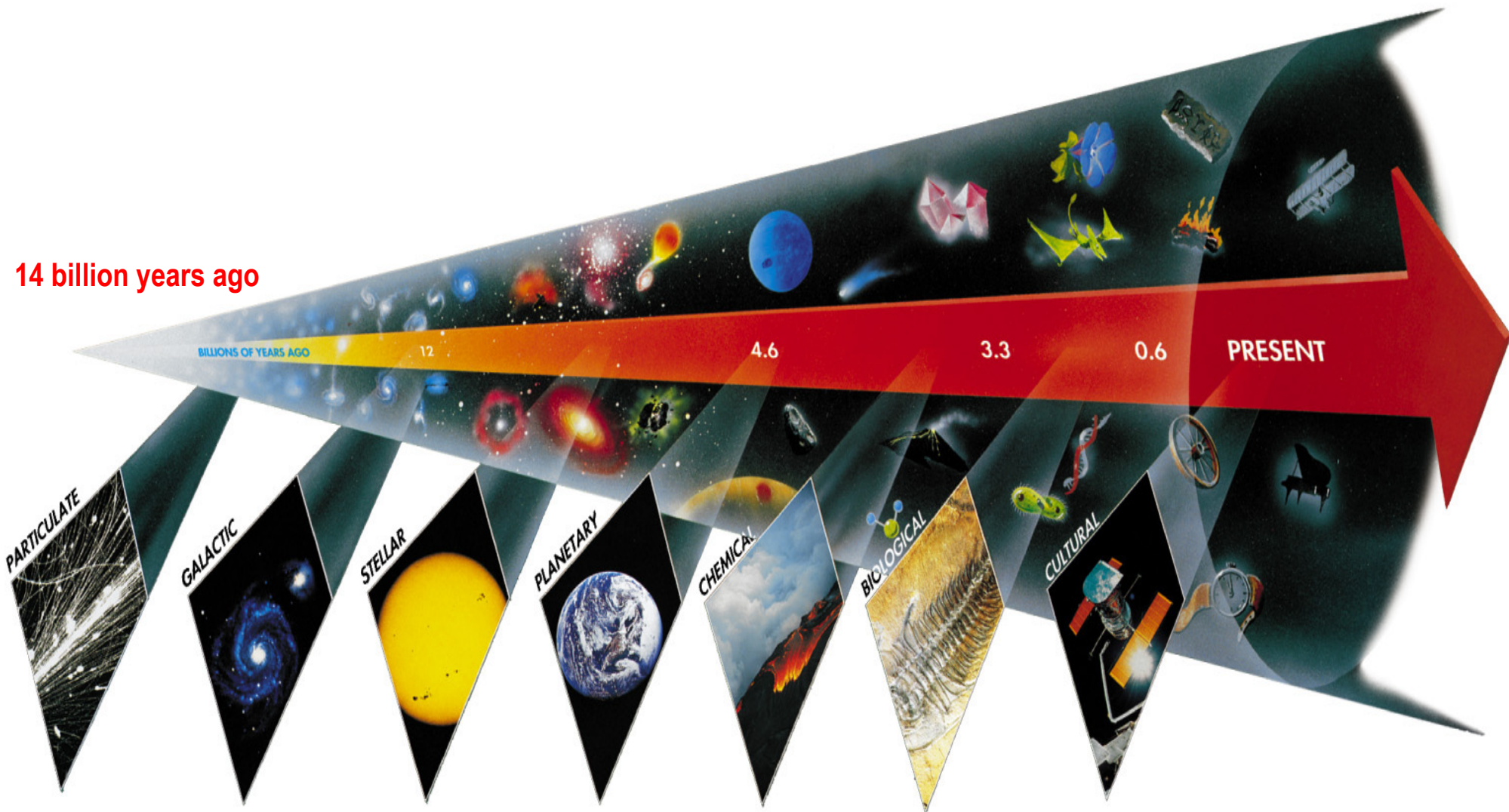

Origin of  
Particles

Origin of  
Structure

# Formation of Structure in the Universe

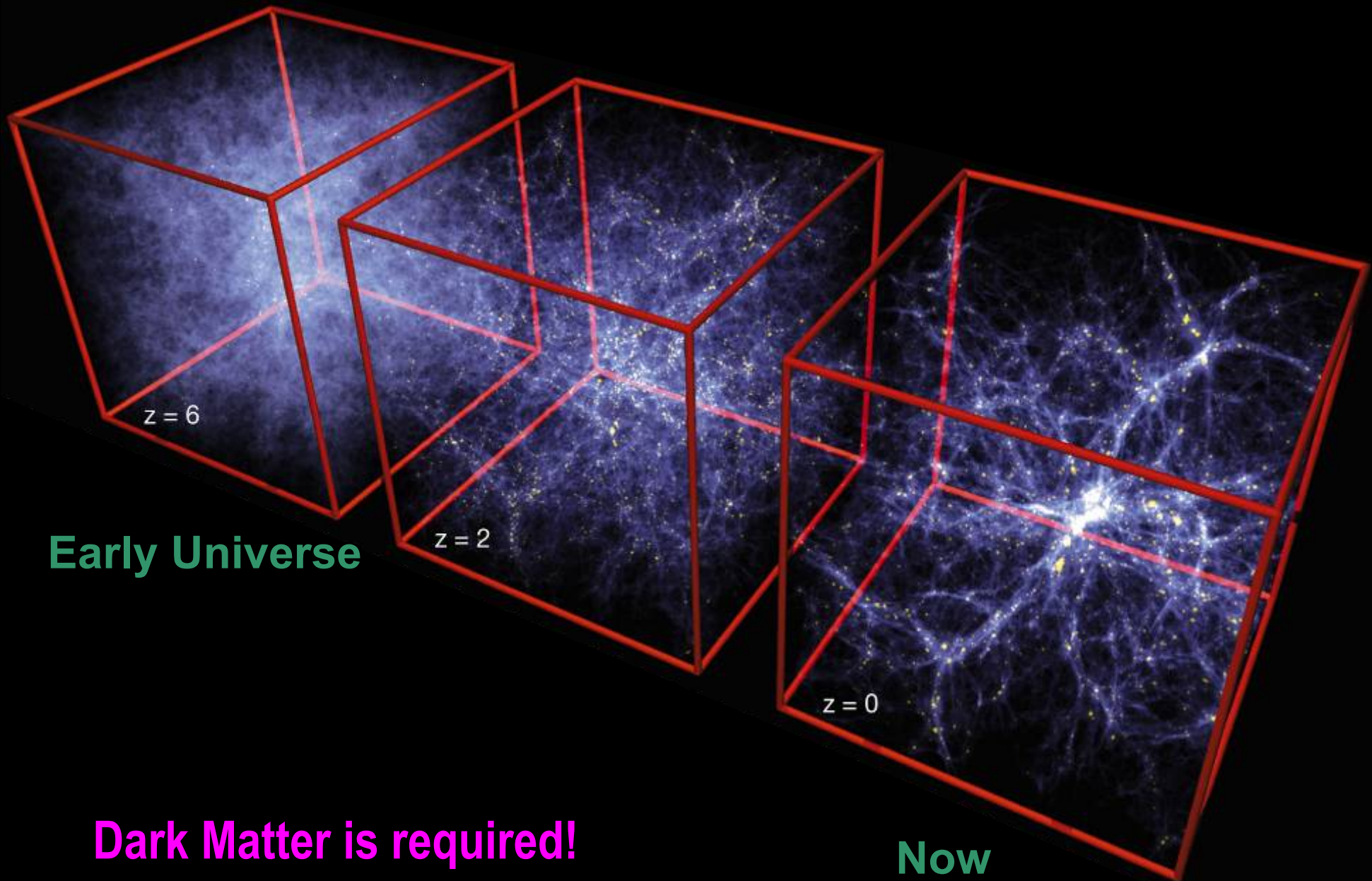

**Dark Matter is required!**

**Now**



**Dark Matter is required!**

**ANDROMEDA  
GALAXY.**

# Laboratori Nazionali del Gran Sasso, Italy

LNGS 1400 m Rock (3100 w.m.e)



# XENON100 Detector

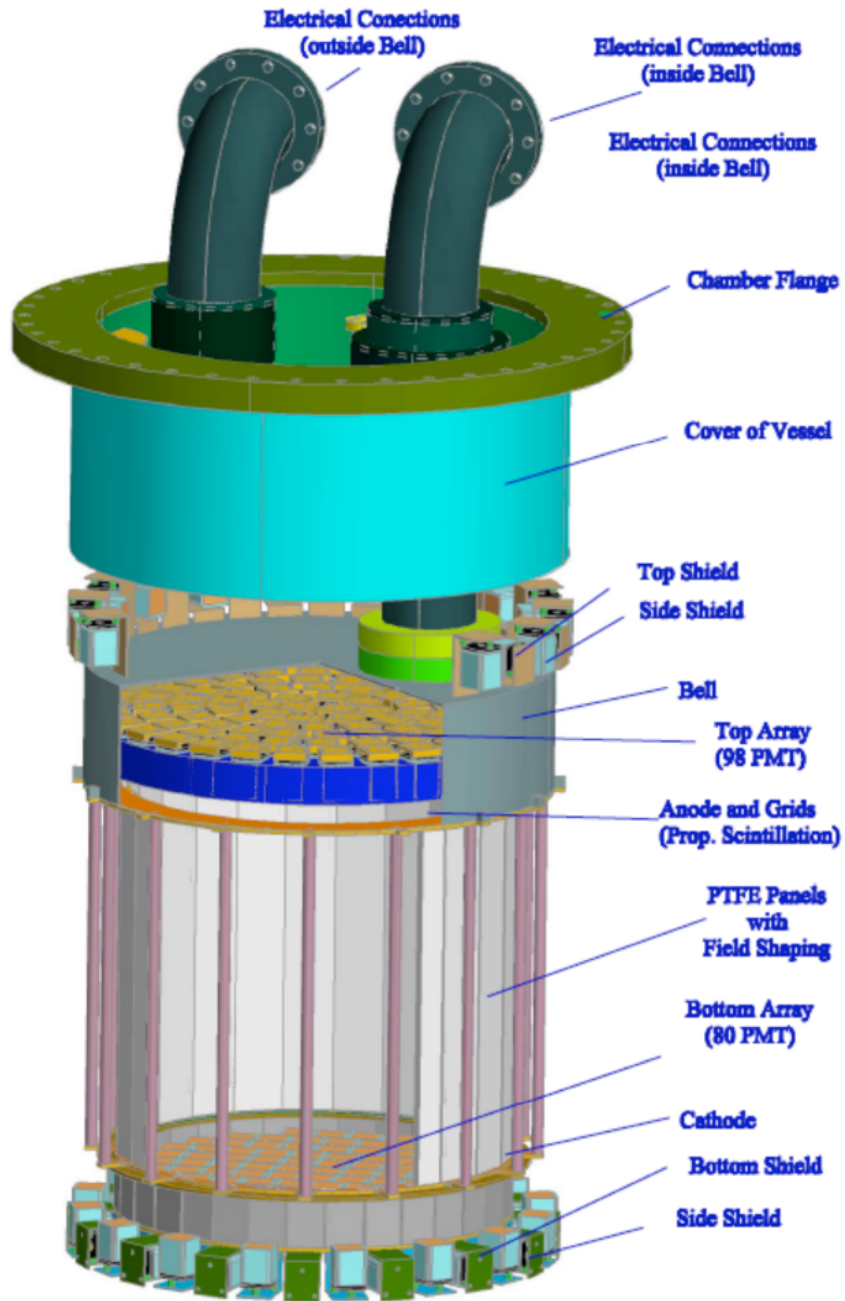

# Evolution of a Star like Sun

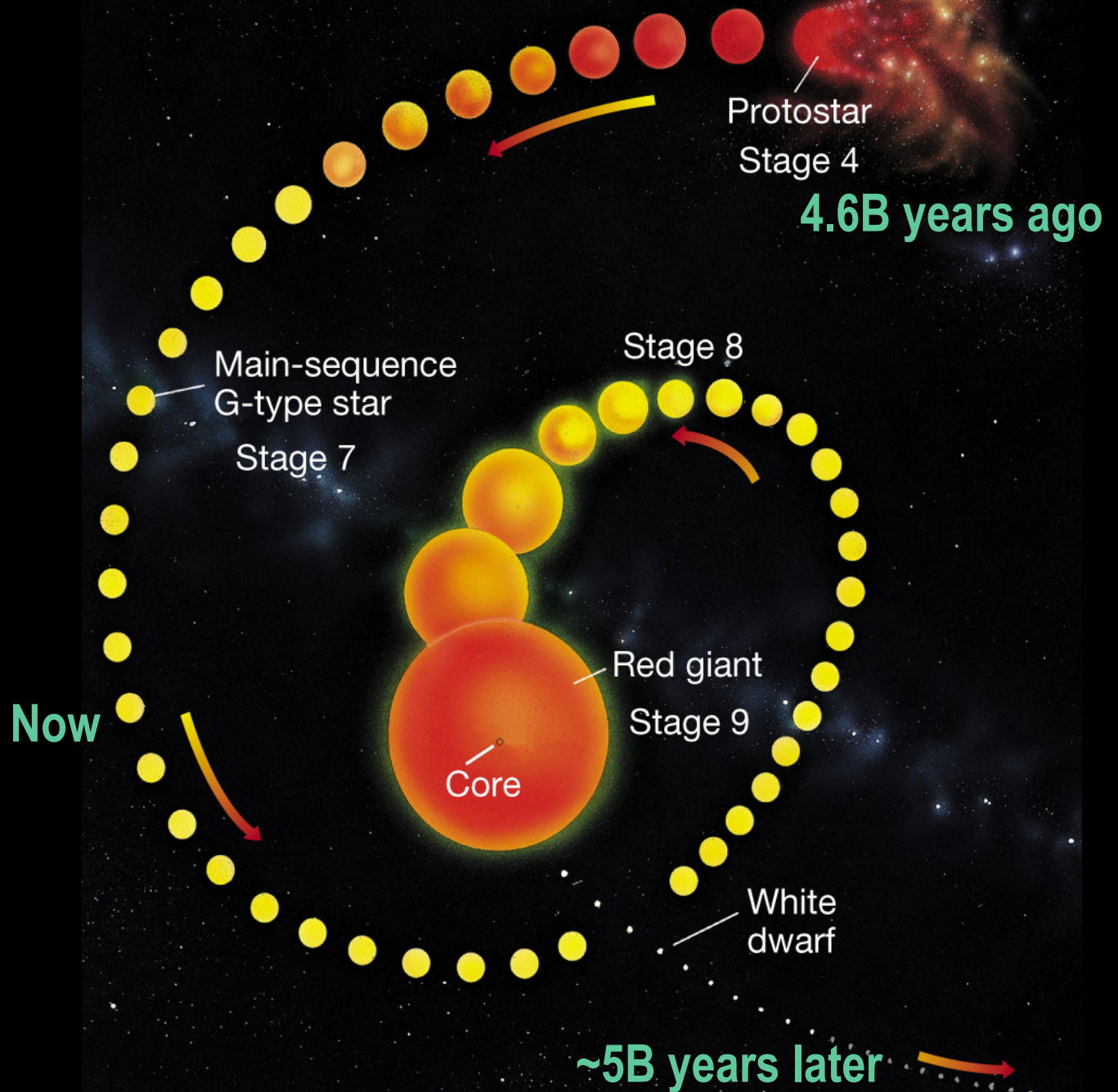

# Nuclear Burning in High Mass Stars

(20 times solar mass star)

Hydrogen	$10^7$ year
Helium	$10^6$ year
Carbon	$10^3$ year
Oxygen	1 year
Neon	
Magnesium	
Silicon	1 week
Iron	< 1 day



**Supernova explosion!**

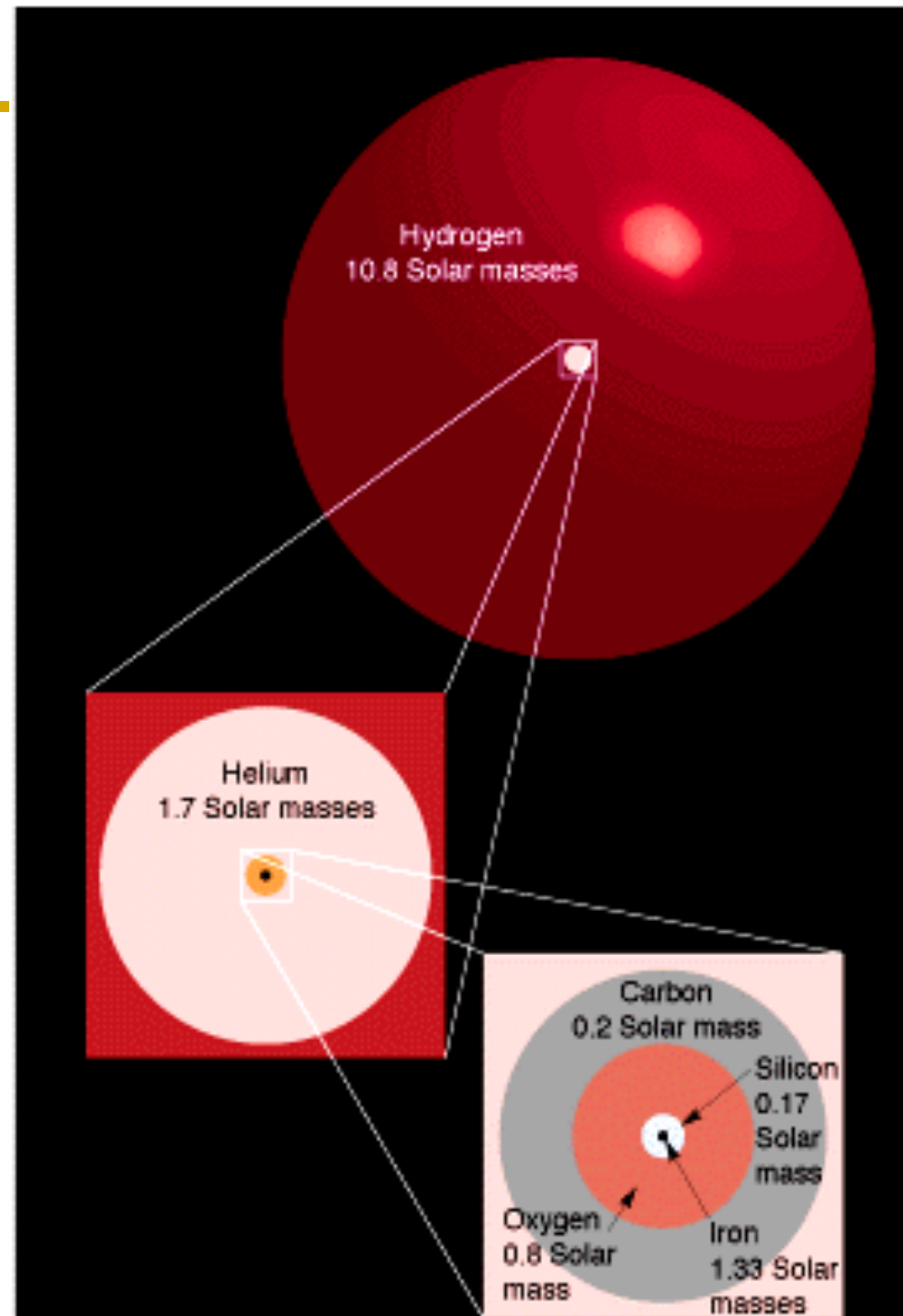

# Origin of Elements

## ➤ Hydrogen, Helium

- From “**Big Bang**”

## ➤ Carbon – Oxygen – Iron

- From “**Nuclear fusion**” at massive stars  
( $> 8 M_{\text{sun}}$ )

## ➤ Heavier than Iron (Cu, Au, Pt, Pb...)

- From “**Supernova**”

---

**We are made  
from “stardust”**

# Star's Life Cycle

Big Bang! (14 B years ago)

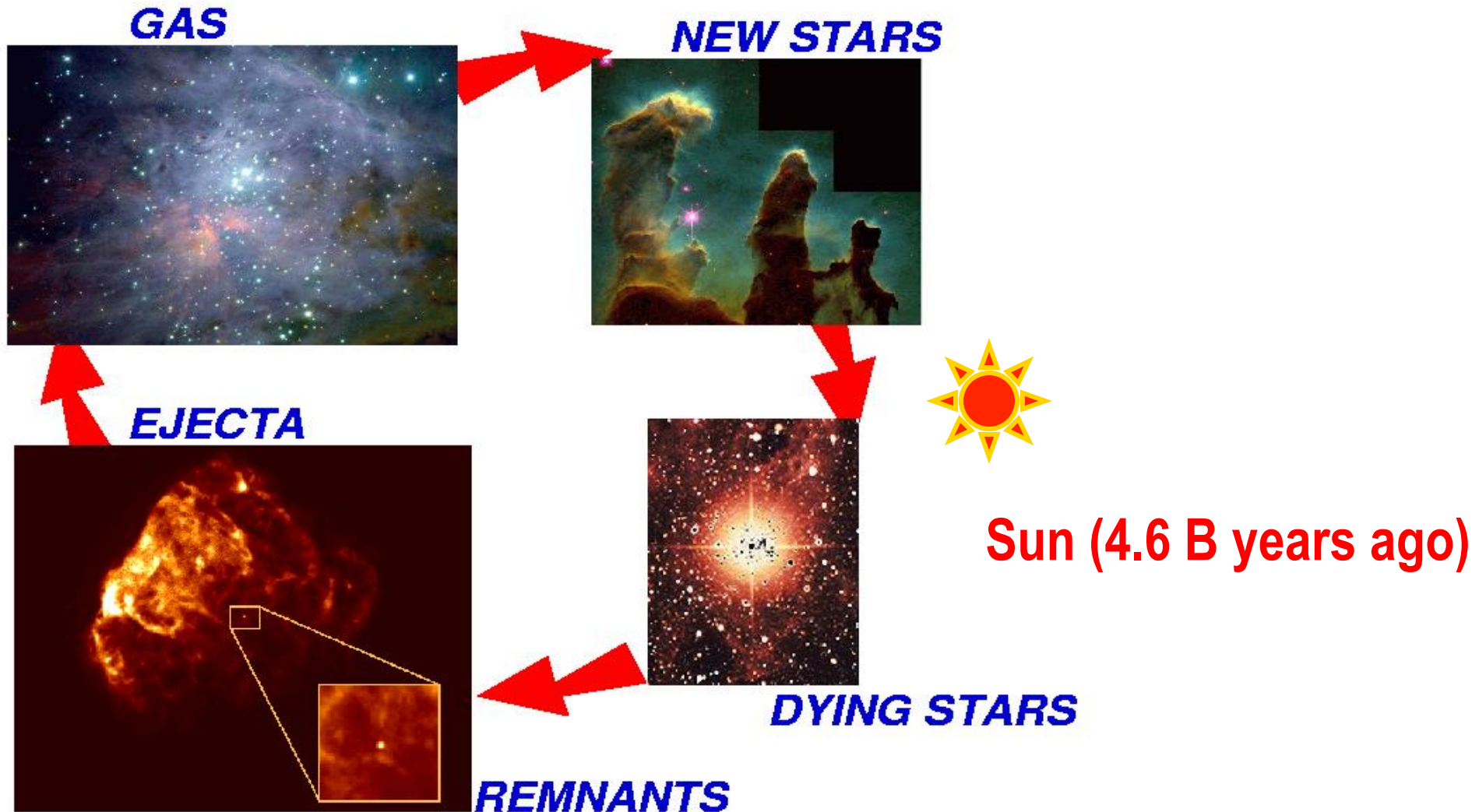

# Solar System (4.6 B years ago)

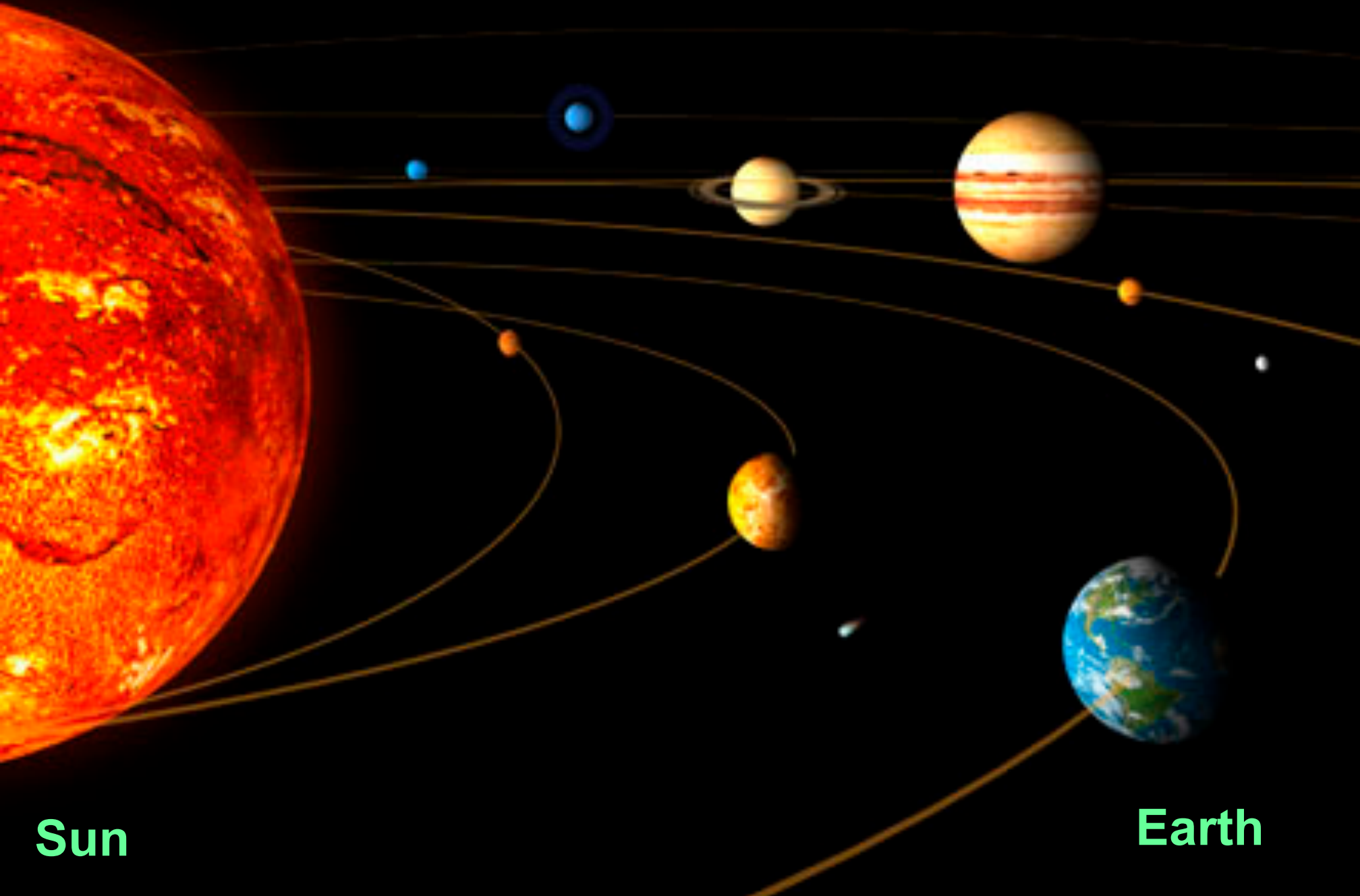

Sun

Earth



**Now we are here!**

# History of the Universe

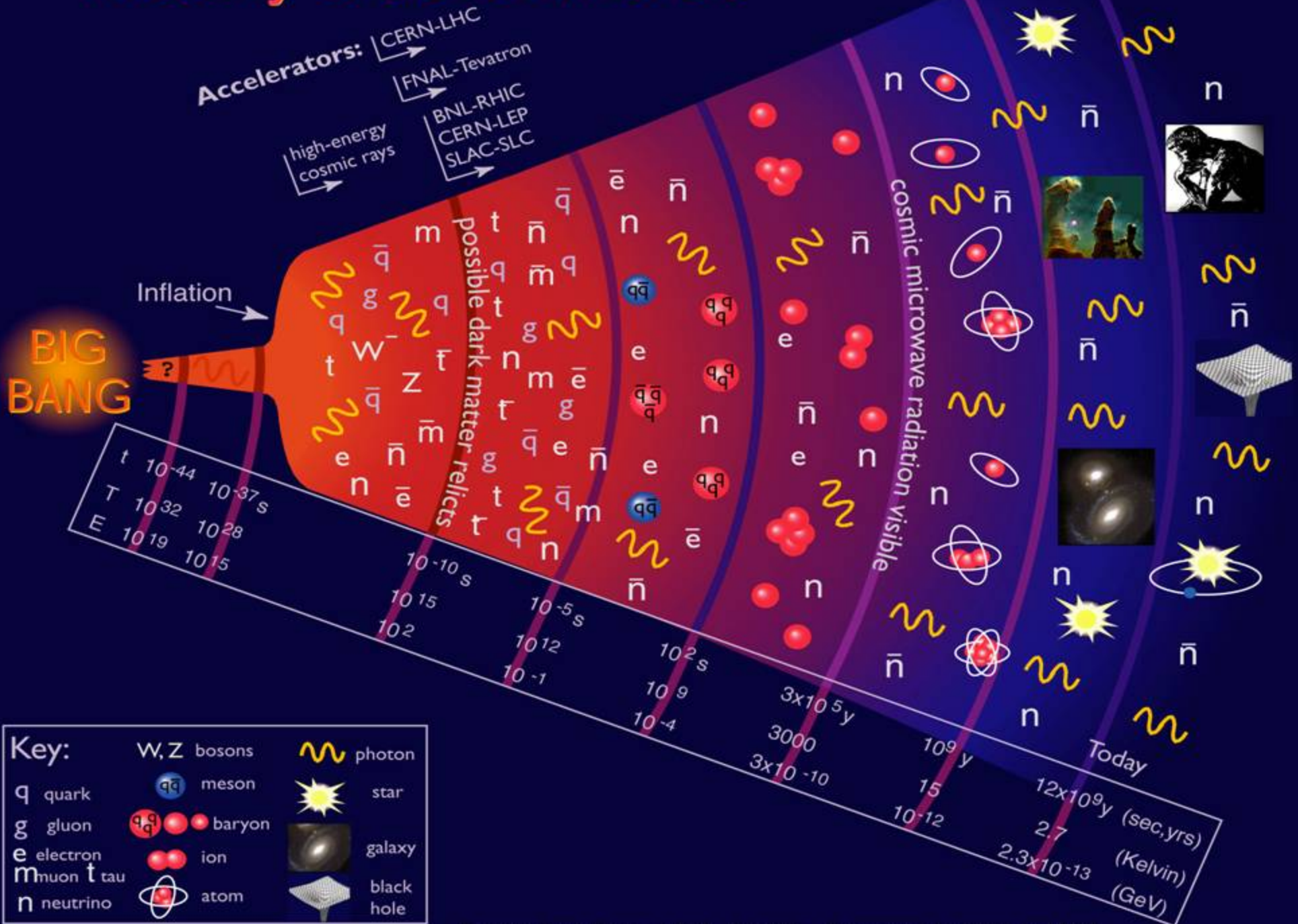

**Are there more than  
one Universe?**

# Linde's Multiverse by Chaotic Inflation

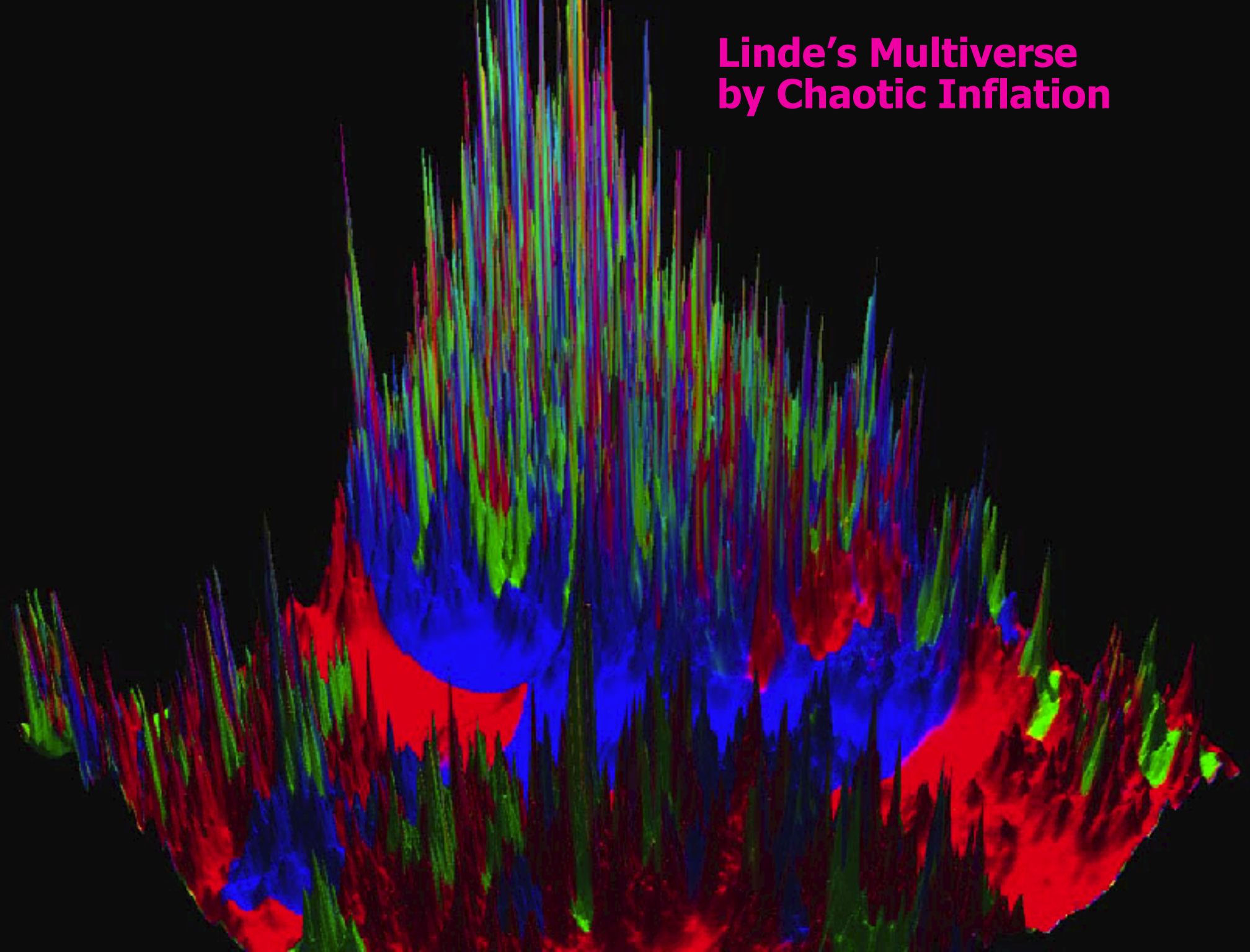



**There may be ~100 Billion Universes.**

# Cyclic Model

M theory

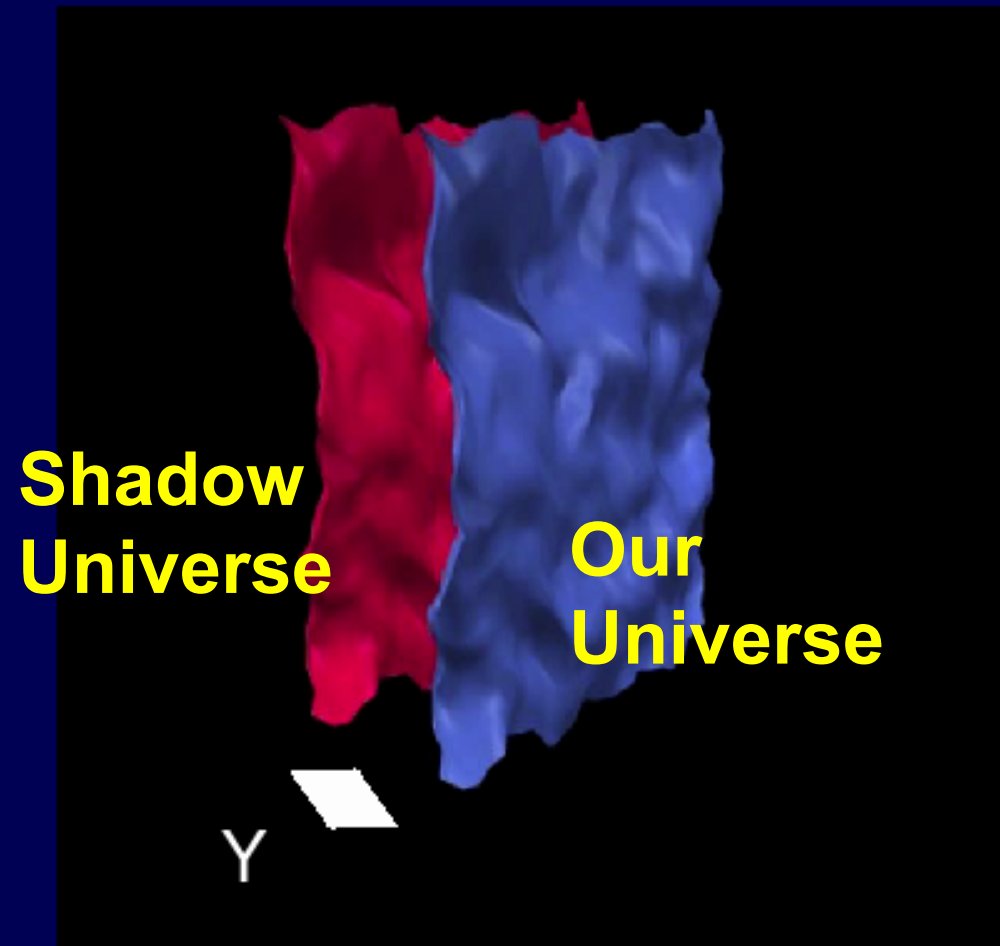
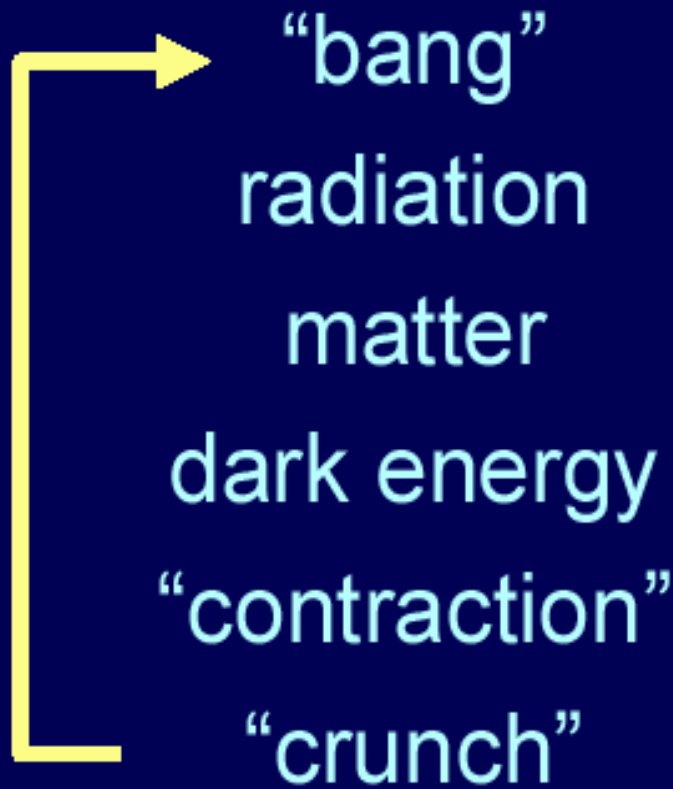

# Seven Phases of Cosmic Evolution

