

Exploring the Origin of Consciousness by high-speed Optical Microscopes

Katsushi Arisaka

***University of California, Los Angeles
Department of Physics and Astronomy***



Why are we here?

Seven Phases of Cosmic Evolution

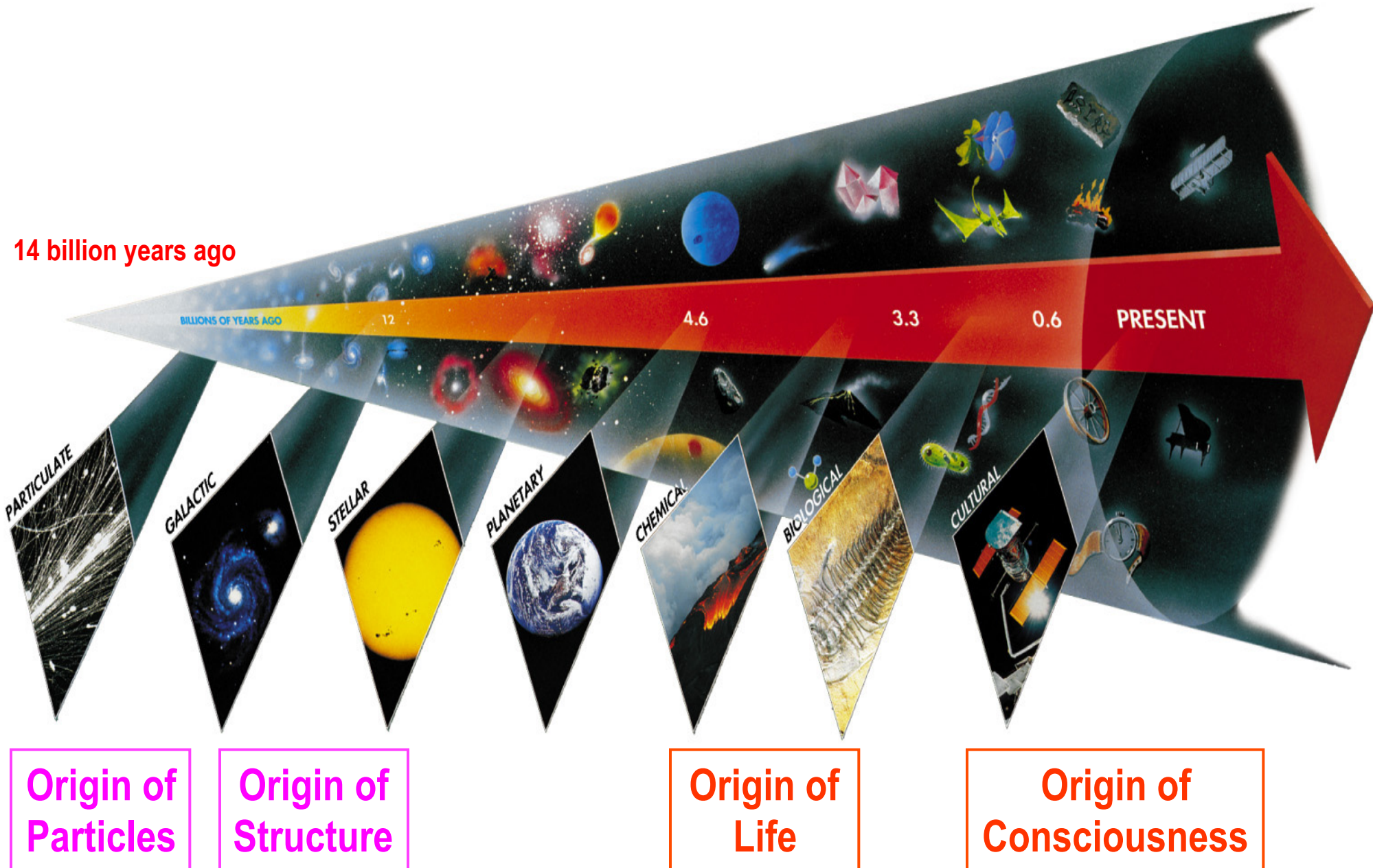

Unification of Forces

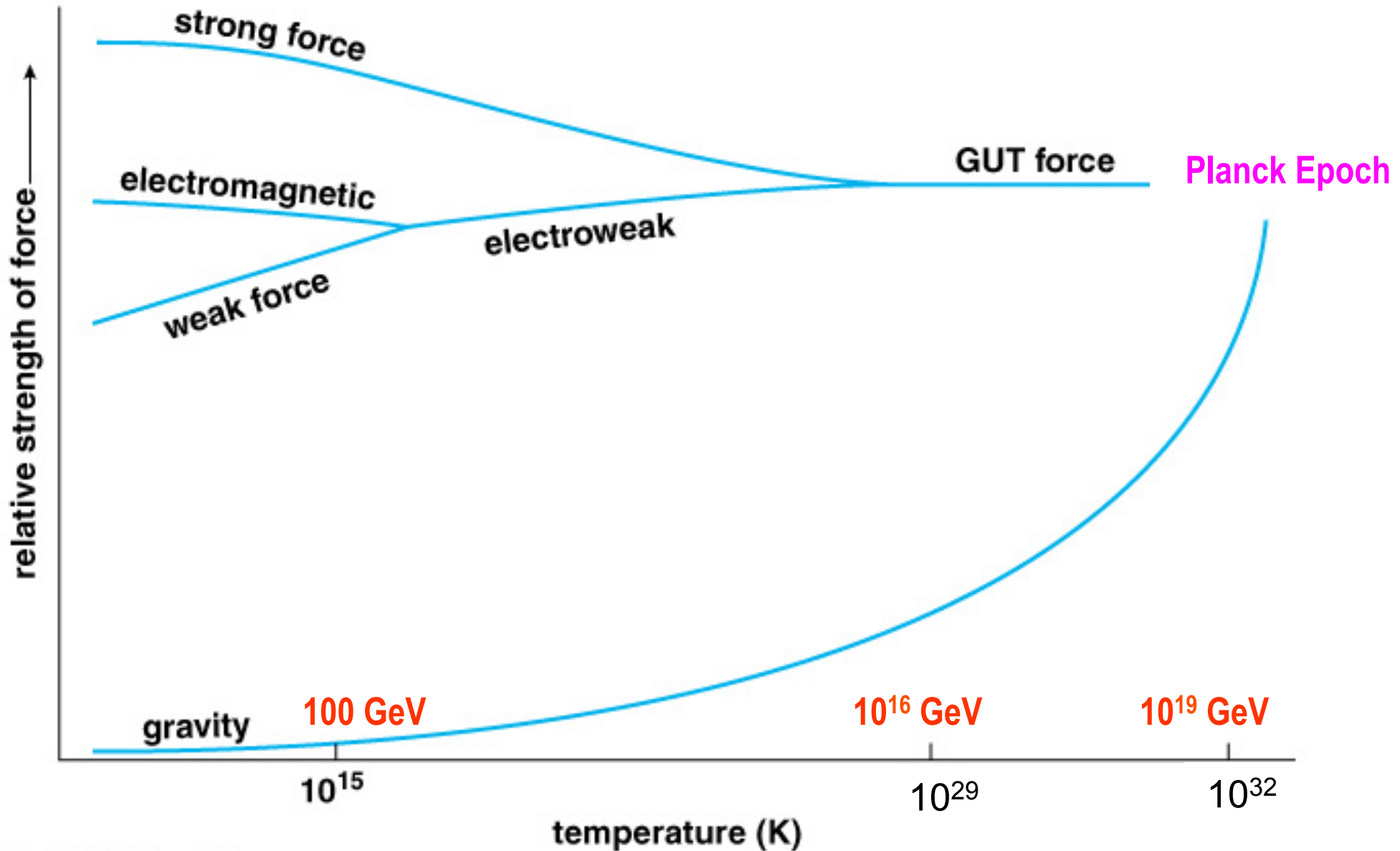

Copyright © Addison Wesley.

Physicists' View of Early Universe

Lorentz Invariance
Local Gauge Invariance

Structure of DNA

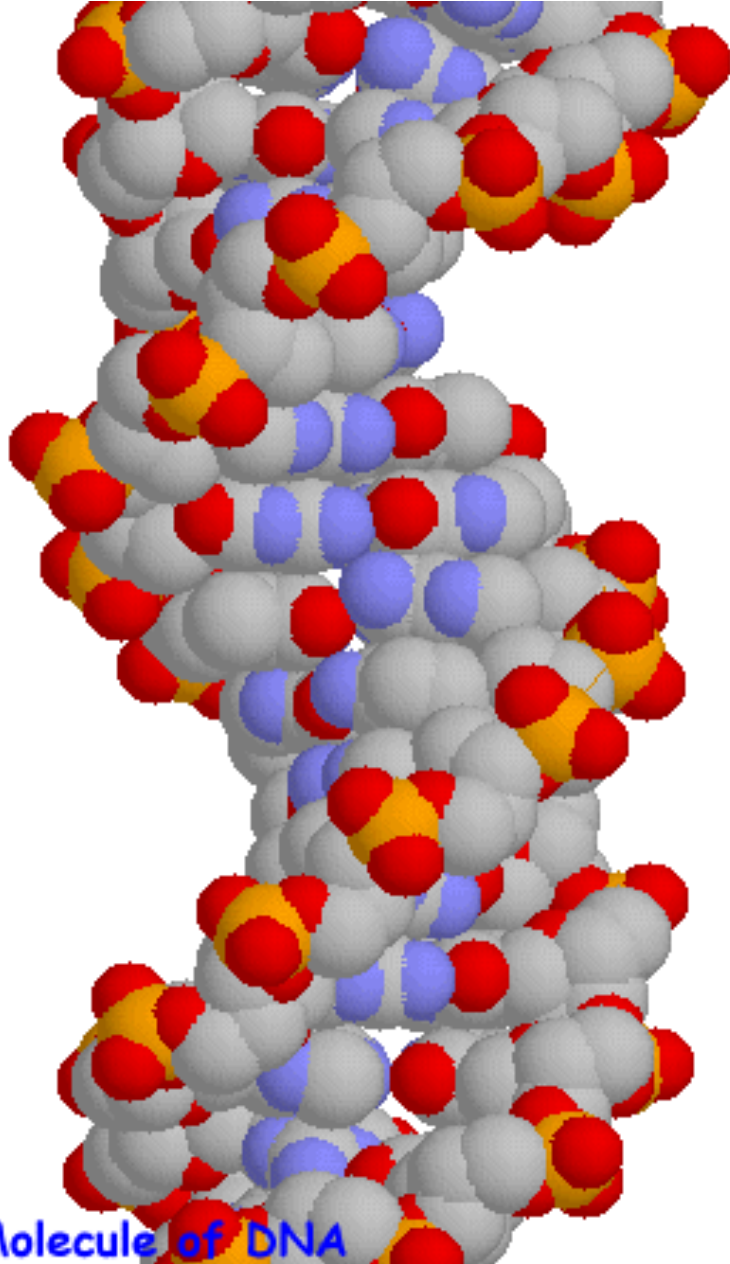

©Rothamsted Experimental Station, 1997, 1998

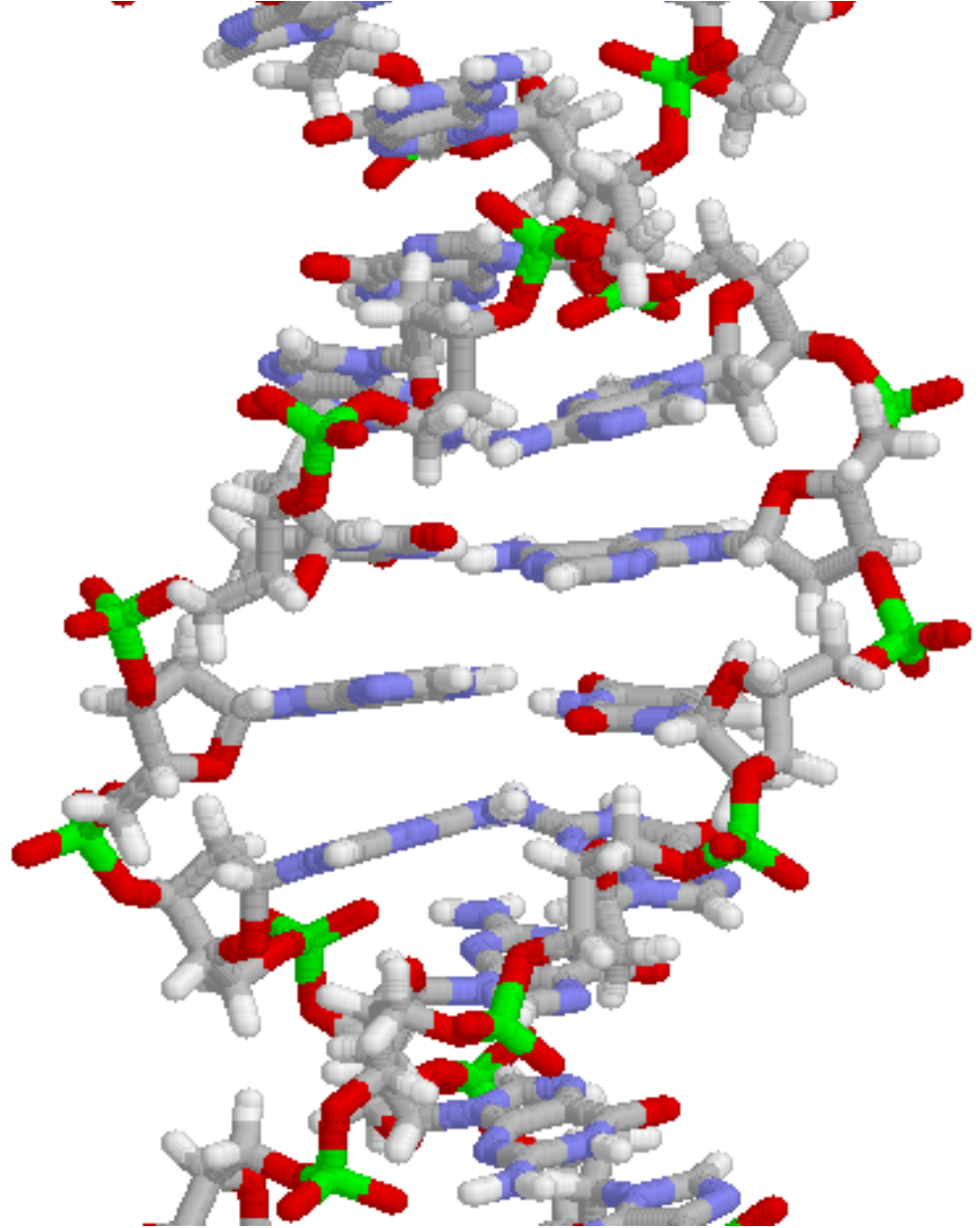

Molecule of DNA

Symmetry Breaking

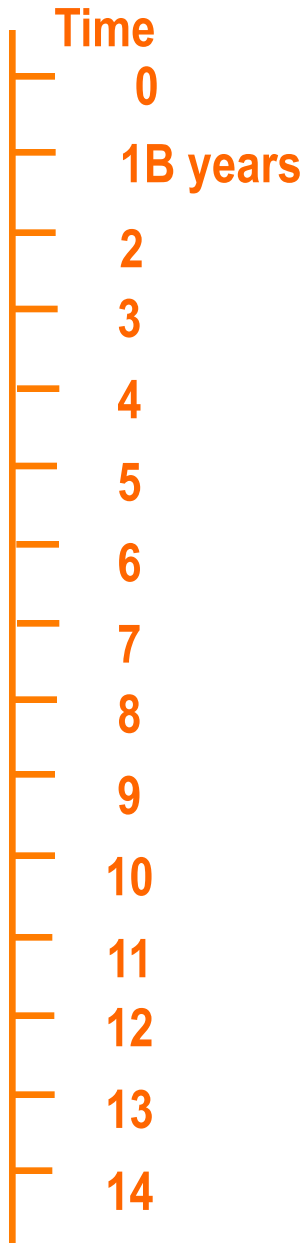

Simple

*Symmetry
Break Down*

Complex

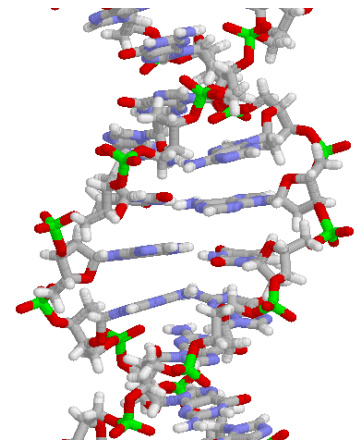
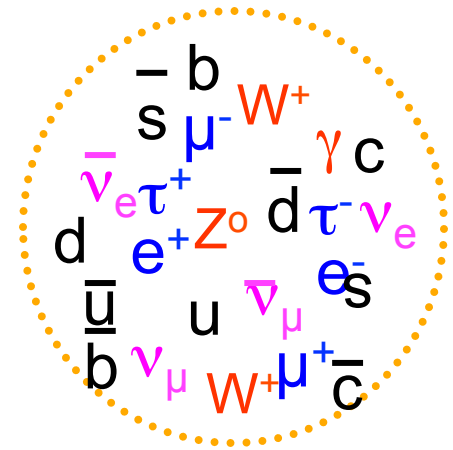

CERN and LHC in Geneva

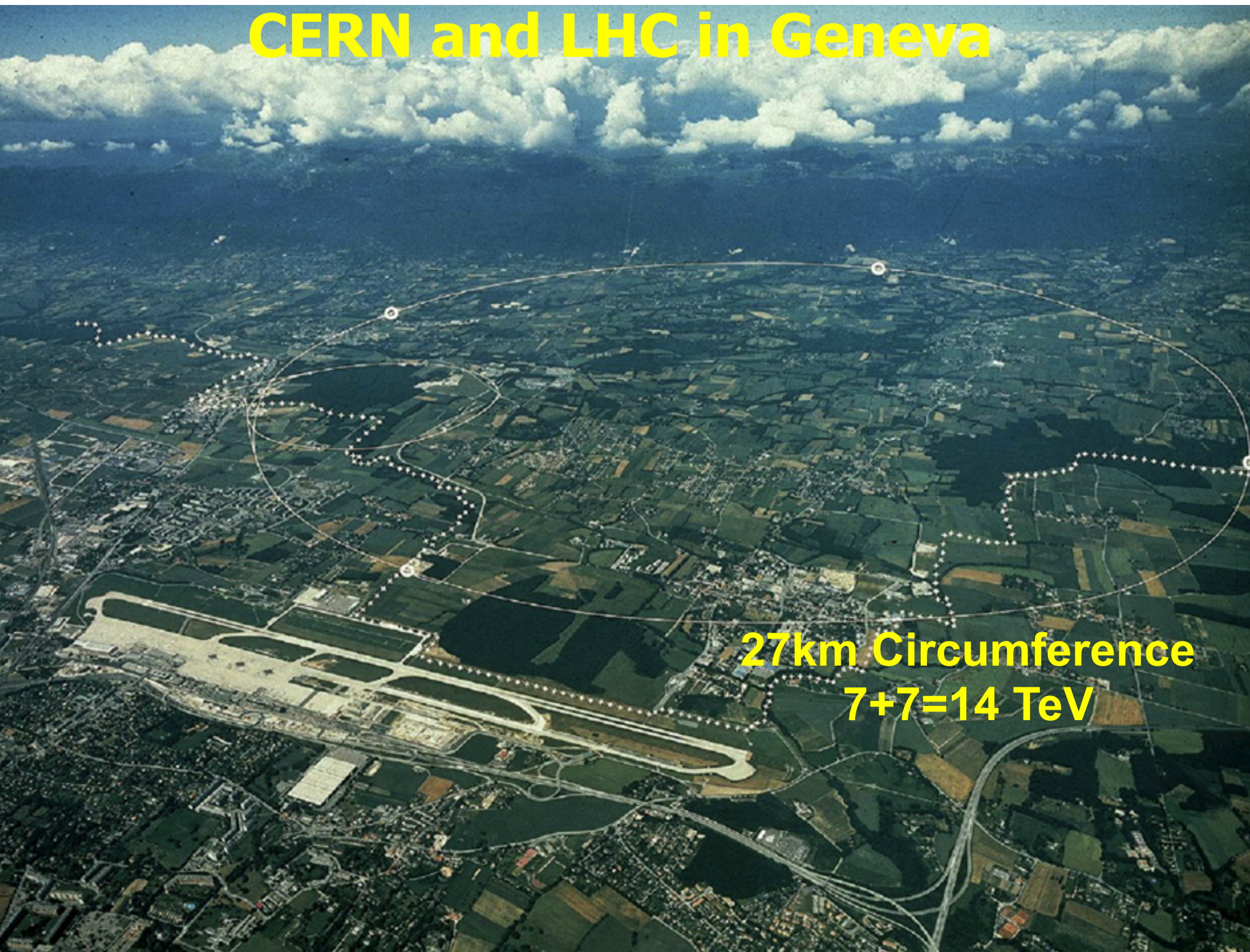

27km Circumference
7+7=14 TeV

LHC Tunnel with Magnets

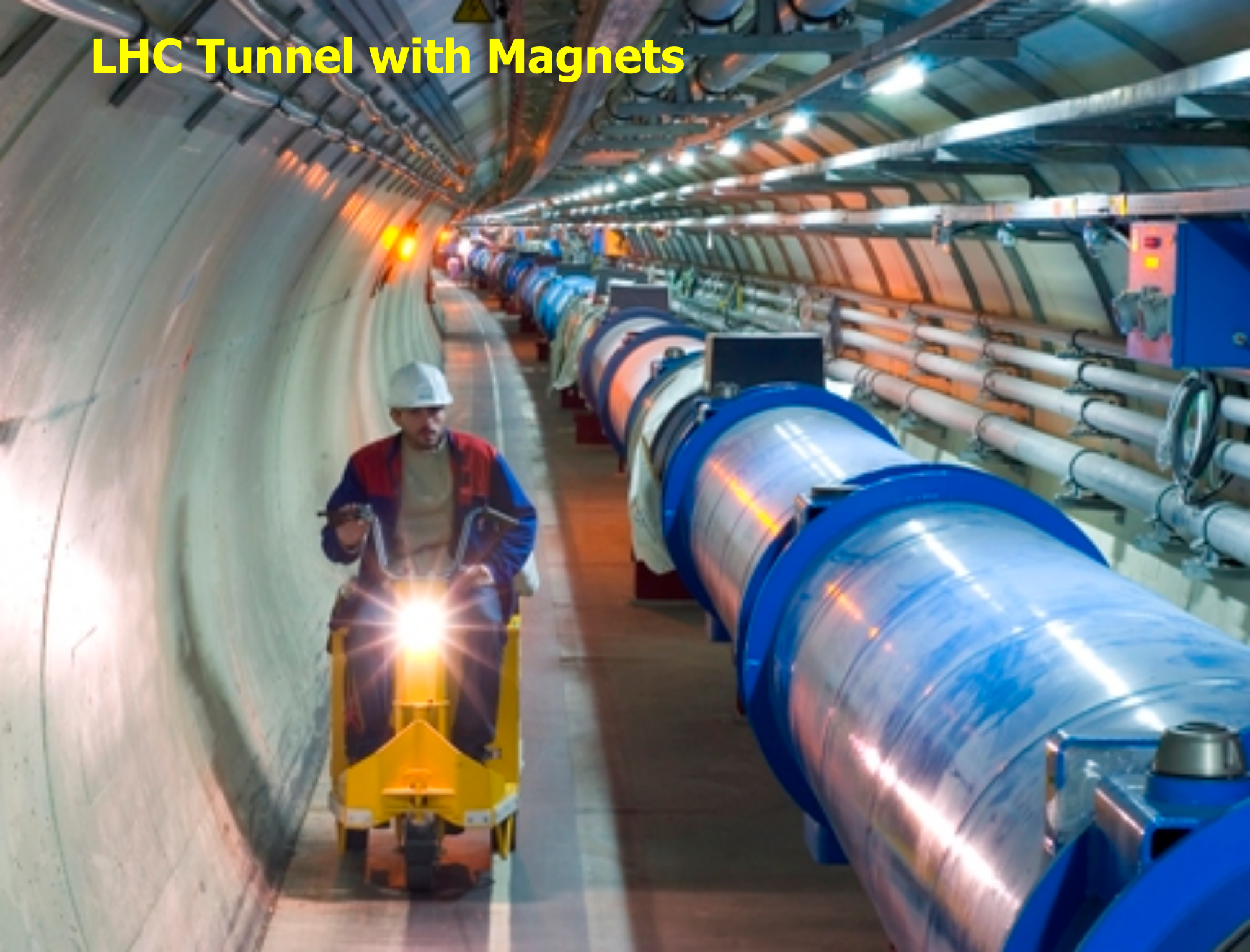

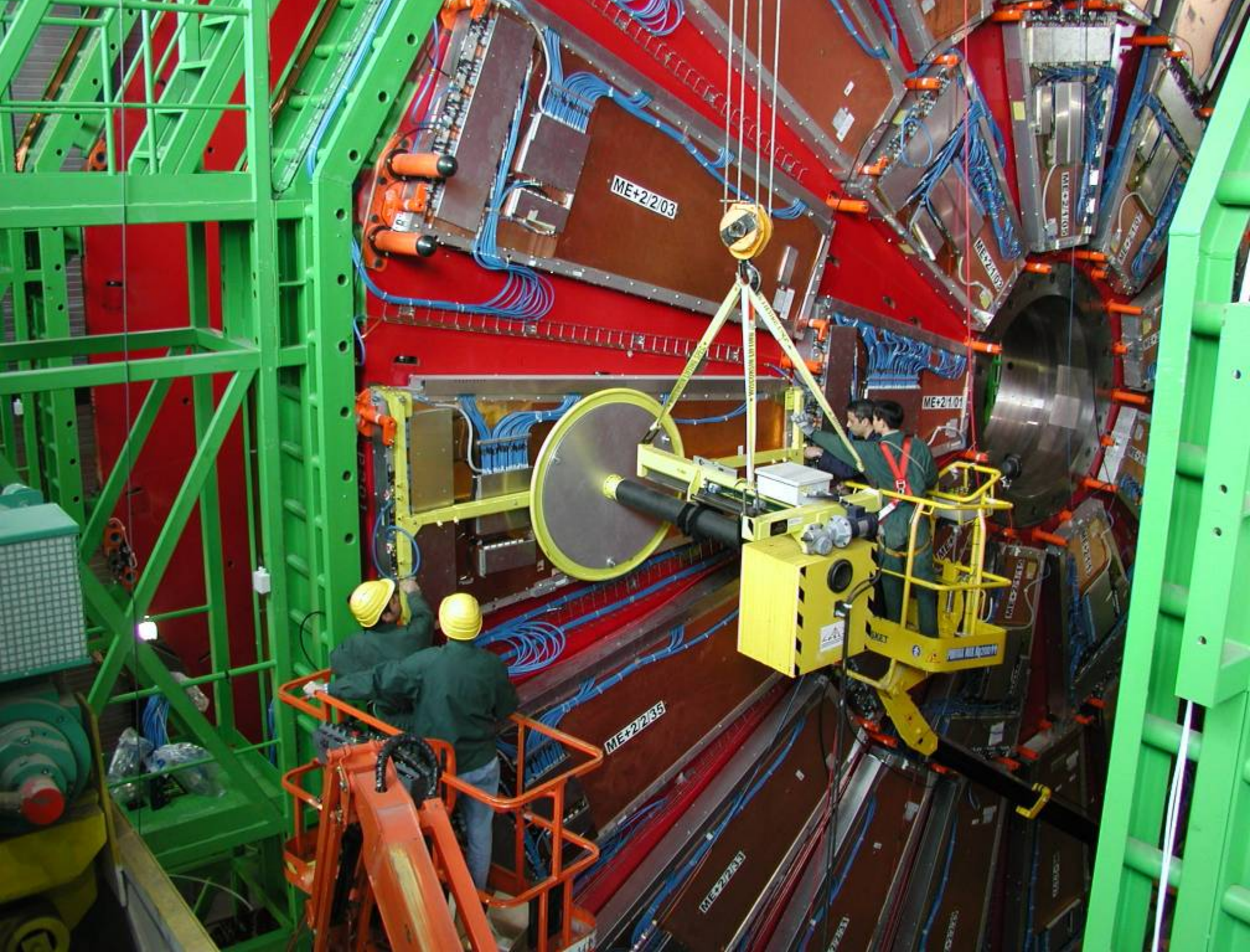

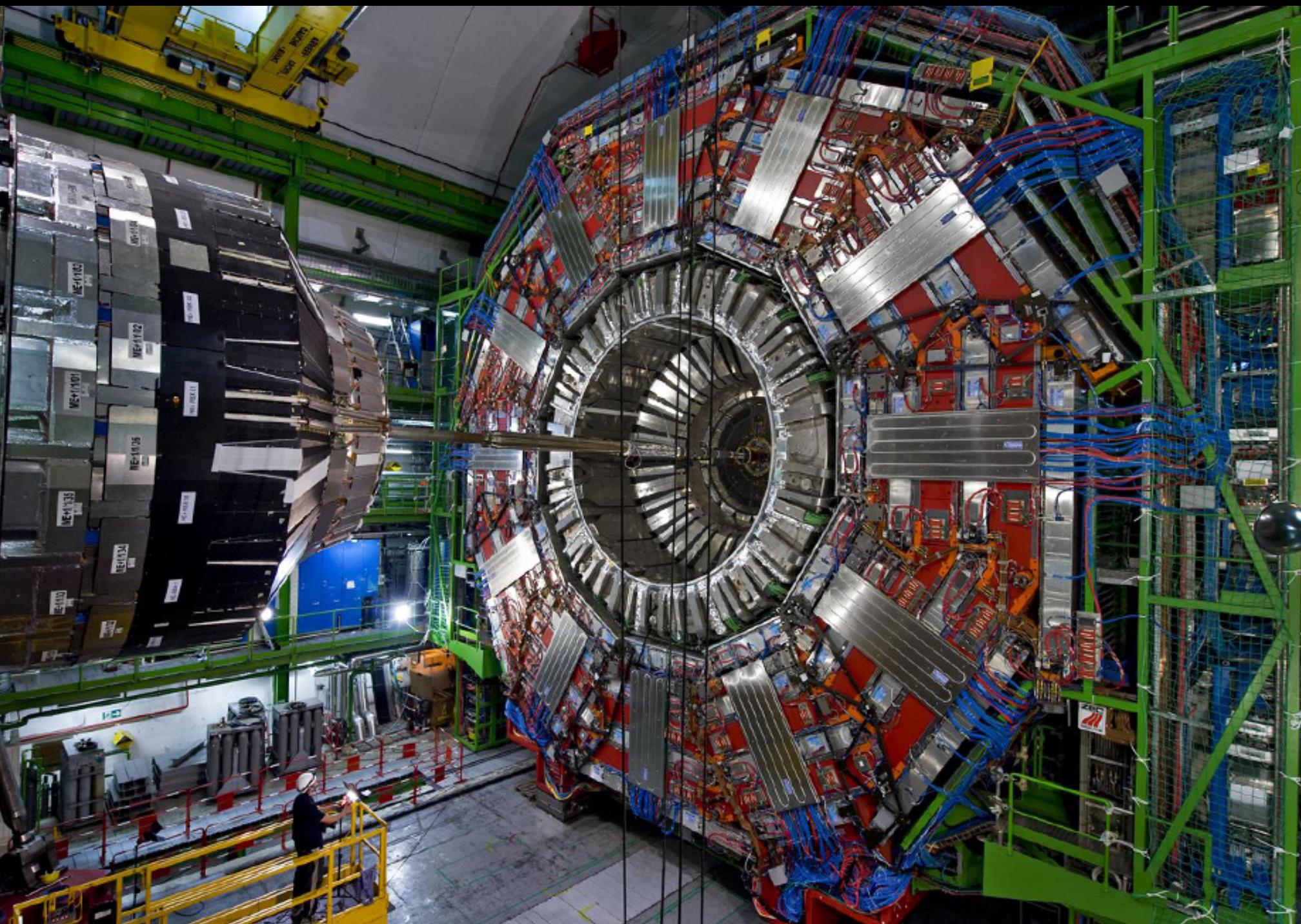

4/11/2012

Katsushi Arisaka, UCLA

12

Sept 15, 2008

Newsweek

The Biggest Experiment Ever (And It's European)



PHOTOGRAPH BY MARTIAL TREZZINI—AP
newsweek.com SEPTEMBER 15, 2008

The new CERN collider in Geneva

CMS End-cap
Muon Chamber
made at Westwood
in 1999 - 2005



Albania	Lek 600	Finland	€4.40	Israel	NIS 20.00	Netherlands	€4.40	Slovenia	€3.40
Austria	€4.40	France	€4.40	Italy	€4.40	Norway	Kr 41.00	Spain	€4.40
Belgium	€4.40	Germany	€4.40	Kazakhstan	\$4.40	Poland (incl tax)	PLN 12.30	Sweden	SKr 34.00
Bulgaria	BGL 4.50	Gibraltar	£2.90	Latvia	€4.40	Portugal Cont	€4.40	Switzerland	SF 7.70
Croatia	KN 22.00	Greece	€4.40	Lithuania	\$4.40	Romania	Lei 11.00	Turkey	YTL 4.00
Cyprus	€2.58/€4.40	Hungary	Ft. 700.00	Luxembourg	€4.40	Russia	€4.40	Ukraine	\$4.40
Czech Republic	CZK 115.00	Iceland	IKR 390.00	Malta	Lm 1.70/€3.98	Serbia	DIN 240	United Kingdom	£2.80
Denmark	Kr 38.00	Ireland (incl tax)	€4.40	Montenegro	DIN 240	Slovakia	SK 120.00/€3.98	U.S. Forces	\$3.25

4/11/2012

CMS Detector

Data_taken 2009-Nov-07 19:12:36.880368 GMT

Run_no 120015

Event_no 8

Lumi_sec 1

Orbit 584946

Crossing 2603

<http://iguana.cern.ch/isy/>

L1 Triggers:

-
- L1_DoubleHfBitCountsRing1_P1N1
- L1_DoubleHfBitCountsRing2_P1N1
- L1_ETM20
- L1_ETM30
- L1_MinBias_HTT10
- L1_Mu3QE8_Jet6
- L1_SingleEG1
- L1_SingleEG10
- L1_SingleEG12
- L1_SingleEG15
- L1_SingleEG20
- L1_SingleEG25
- L1_SingleEG30
- L1_SingleEG35
- L1_SingleEG40
- L1_SingleEG45
- L1_SingleEG50
- L1_SingleEG55
- L1_SingleEG60
- L1_SingleEG65
- L1_SingleEG70
- L1_SingleEG75
- L1_SingleEG80
- L1_SingleEG85
- L1_SingleEG90
- L1_SingleEG95
- L1_SingleEG100
- L1_SingleEG105
- L1_SingleEG110
- L1_SingleEG115
- L1_SingleEG120
- L1_SingleEG125
- L1_SingleEG130
- L1_SingleEG135
- L1_SingleEG140
- L1_SingleEG145
- L1_SingleEG150
- L1_SingleEG155
- L1_SingleEG160
- L1_SingleEG165
- L1_SingleEG170
- L1_SingleEG175
- L1_SingleEG180
- L1_SingleEG185
- L1_SingleEG190
- L1_SingleEG195
- L1_SingleEG200
- L1_SingleEG205
- L1_SingleEG210
- L1_SingleEG215
- L1_SingleEG220
- L1_SingleEG225
- L1_SingleEG230
- L1_SingleEG235
- L1_SingleEG240
- L1_SingleEG245
- L1_SingleEG250
- L1_SingleEG255
- L1_SingleEG260
- L1_SingleEG265
- L1_SingleEG270
- L1_SingleEG275
- L1_SingleEG280
- L1_SingleEG285
- L1_SingleEG290
- L1_SingleEG295
- L1_SingleEG300
- L1_SingleEG305
- L1_SingleEG310
- L1_SingleEG315
- L1_SingleEG320
- L1_SingleEG325
- L1_SingleEG330
- L1_SingleEG335
- L1_SingleEG340
- L1_SingleEG345
- L1_SingleEG350
- L1_SingleEG355
- L1_SingleEG360
- L1_SingleEG365
- L1_SingleEG370
- L1_SingleEG375
- L1_SingleEG380
- L1_SingleEG385
- L1_SingleEG390
- L1_SingleEG395
- L1_SingleEG400
- L1_SingleEG405
- L1_SingleEG410
- L1_SingleEG415
- L1_SingleEG420
- L1_SingleEG425
- L1_SingleEG430
- L1_SingleEG435
- L1_SingleEG440
- L1_SingleEG445
- L1_SingleEG450
- L1_SingleEG455
- L1_SingleEG460
- L1_SingleEG465
- L1_SingleEG470
- L1_SingleEG475
- L1_SingleEG480
- L1_SingleEG485
- L1_SingleEG490
- L1_SingleEG495
- L1_SingleEG500
- L1_SingleEG505
- L1_SingleEG510
- L1_SingleEG515
- L1_SingleEG520
- L1_SingleEG525
- L1_SingleEG530
- L1_SingleEG535
- L1_SingleEG540
- L1_SingleEG545
- L1_SingleEG550
- L1_SingleEG555
- L1_SingleEG560
- L1_SingleEG565
- L1_SingleEG570
- L1_SingleEG575
- L1_SingleEG580
- L1_SingleEG585
- L1_SingleEG590
- L1_SingleEG595
- L1_SingleEG600
- L1_SingleEG605
- L1_SingleEG610
- L1_SingleEG615
- L1_SingleEG620
- L1_SingleEG625
- L1_SingleEG630
- L1_SingleEG635
- L1_SingleEG640
- L1_SingleEG645
- L1_SingleEG650
- L1_SingleEG655
- L1_SingleEG660
- L1_SingleEG665
- L1_SingleEG670
- L1_SingleEG675
- L1_SingleEG680
- L1_SingleEG685
- L1_SingleEG690
- L1_SingleEG695
- L1_SingleEG700
- L1_SingleEG705
- L1_SingleEG710
- L1_SingleEG715
- L1_SingleEG720
- L1_SingleEG725
- L1_SingleEG730
- L1_SingleEG735
- L1_SingleEG740
- L1_SingleEG745
- L1_SingleEG750
- L1_SingleEG755
- L1_SingleEG760
- L1_SingleEG765
- L1_SingleEG770
- L1_SingleEG775
- L1_SingleEG780
- L1_SingleEG785
- L1_SingleEG790
- L1_SingleEG795
- L1_SingleEG800
- L1_SingleEG805
- L1_SingleEG810
- L1_SingleEG815
- L1_SingleEG820
- L1_SingleEG825
- L1_SingleEG830
- L1_SingleEG835
- L1_SingleEG840
- L1_SingleEG845
- L1_SingleEG850
- L1_SingleEG855
- L1_SingleEG860
- L1_SingleEG865
- L1_SingleEG870
- L1_SingleEG875
- L1_SingleEG880
- L1_SingleEG885
- L1_SingleEG890
- L1_SingleEG895
- L1_SingleEG900
- L1_SingleEG905
- L1_SingleEG910
- L1_SingleEG915
- L1_SingleEG920
- L1_SingleEG925
- L1_SingleEG930
- L1_SingleEG935
- L1_SingleEG940
- L1_SingleEG945
- L1_SingleEG950
- L1_SingleEG955
- L1_SingleEG960
- L1_SingleEG965
- L1_SingleEG970
- L1_SingleEG975
- L1_SingleEG980
- L1_SingleEG985
- L1_SingleEG990
- L1_SingleEG995

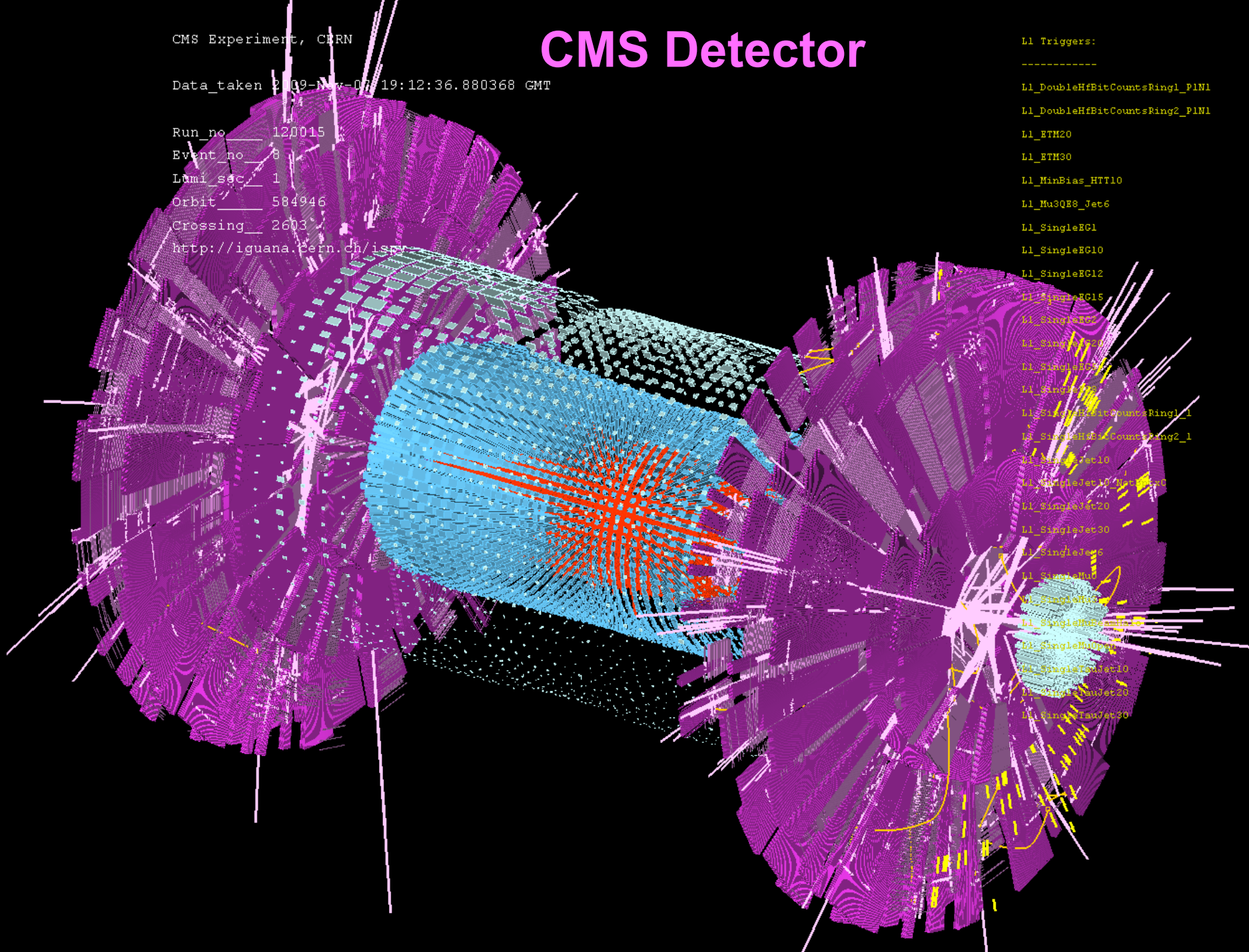

First Event at LHC – Recreation of the Big Bang! (Nov 7, 2009)

Seven steps of cosmic evolution

Spontaneous Symmetry Breaking

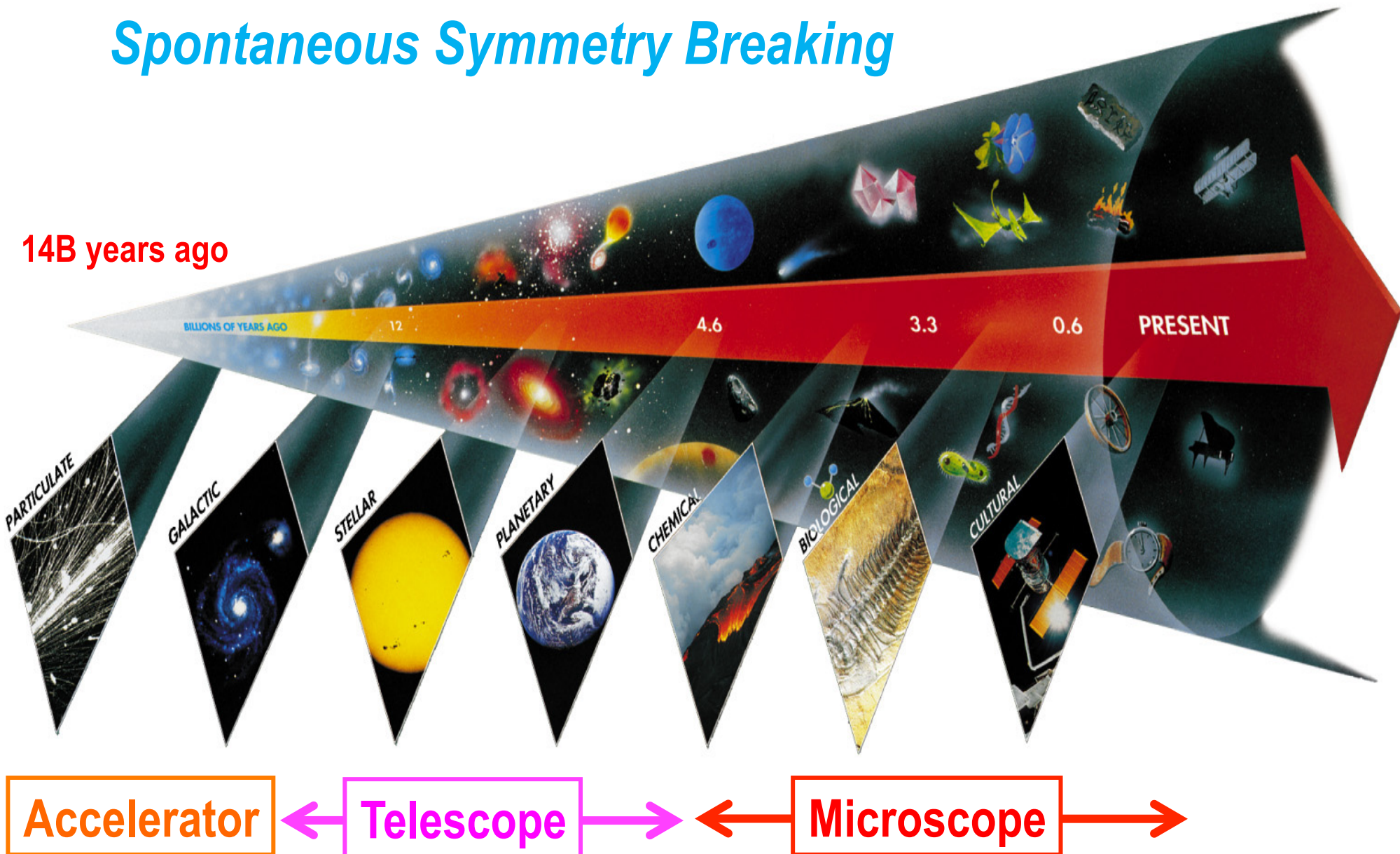

How to observe the Life and Consciousness ?

- We must look for “**Live Life**”
- Exactly the same way as we look for the “**Origin of Universe**”
Telescope ↔ **Microscope**
- Take advantages of the state of art “**Photon Detectors**” in particle physics.

Single Molecule Imaging

January 2006

Shimon Weiss (Chemistry)

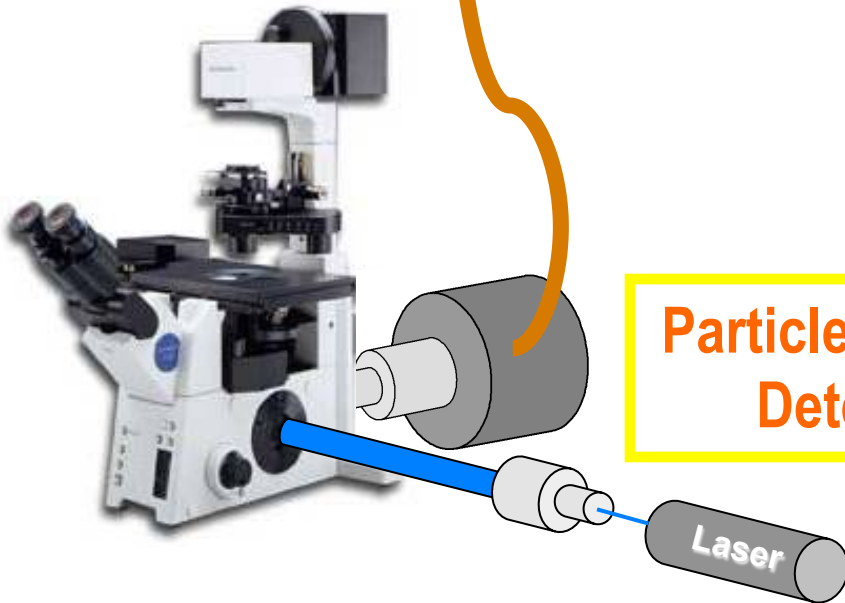

Particle Physics
Detector

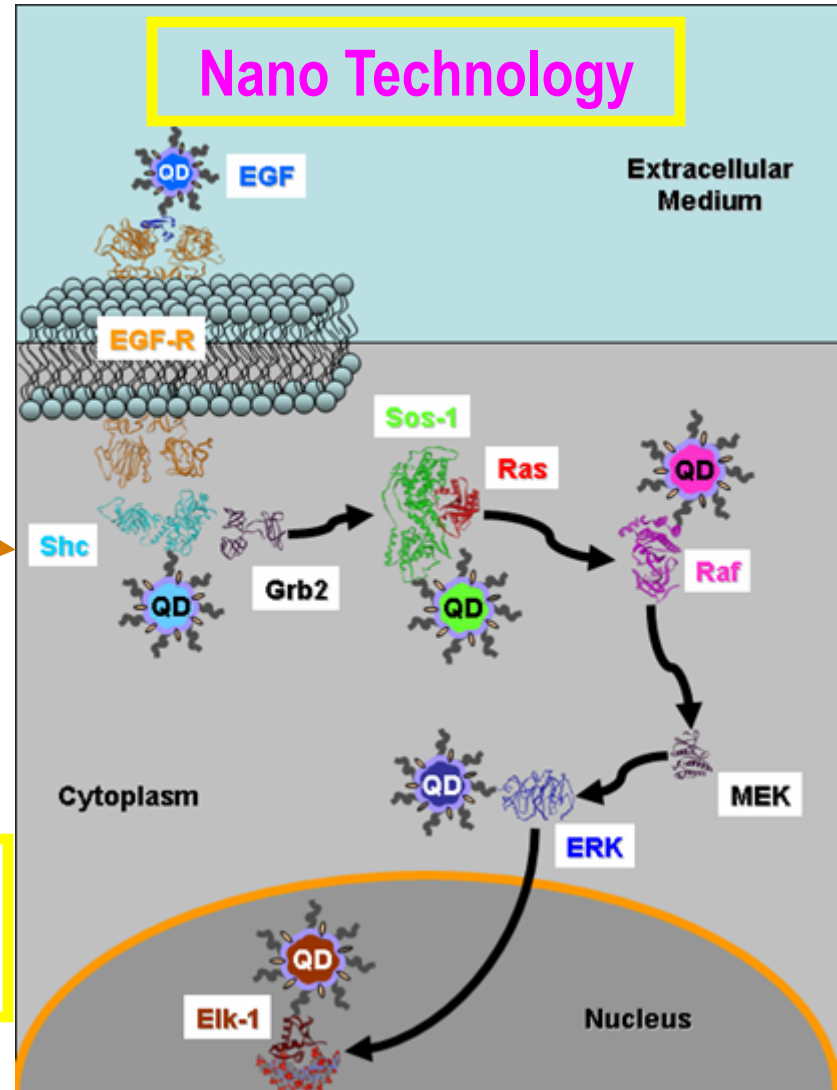

How to speed up microscopes

- All the existing microscopes are limited by the narrow bandwidth of readout.
 - Just one channel of FADC (Flash Analog to Digital Converter) running at 10 – 50 MHz
 - So-called Video Rate (30 frame/sec)
- The first step is to adopt multiple channels of FADC for massive parallel processing.
 - Like high energy experiments (such as LHC)
- In addition, we need Single Photon Sensitivity with high Quantum Efficiency.

Principle of High-speed Bio Imaging

Wide Field

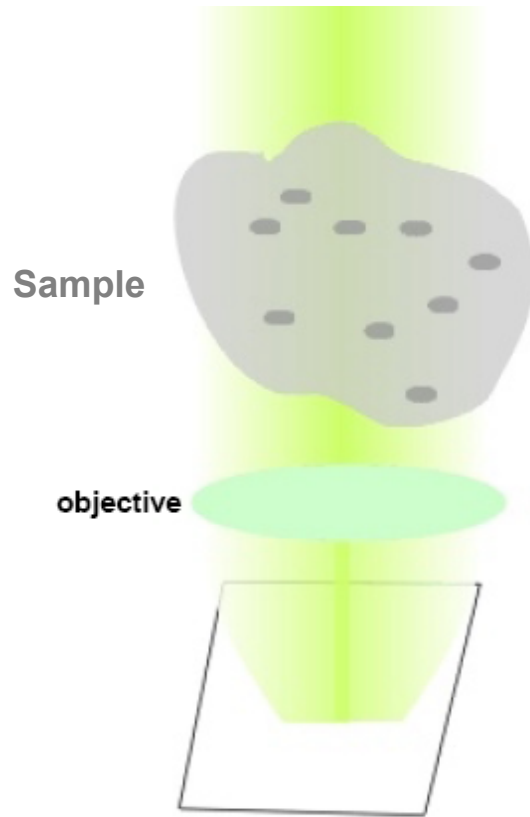

CCD + FADC (10 – 50 MHz)



CMOS [FADC (50 MHz) * 100]

Confocal

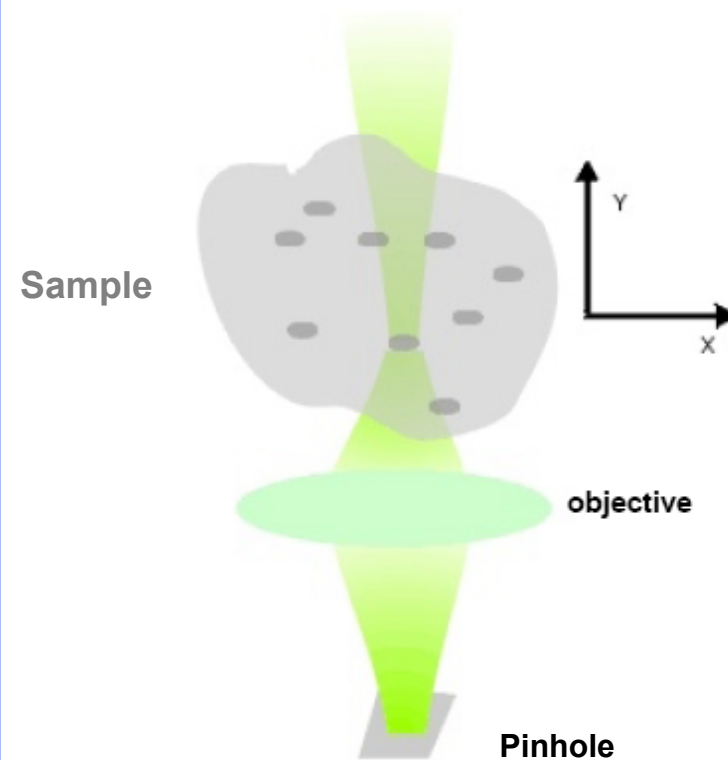

PMT + FADC (10 – 50 MHz)



[HAPD + FADC (1 GHz)] * 64

Micron 1.3M-Pixel CMOS Sensor

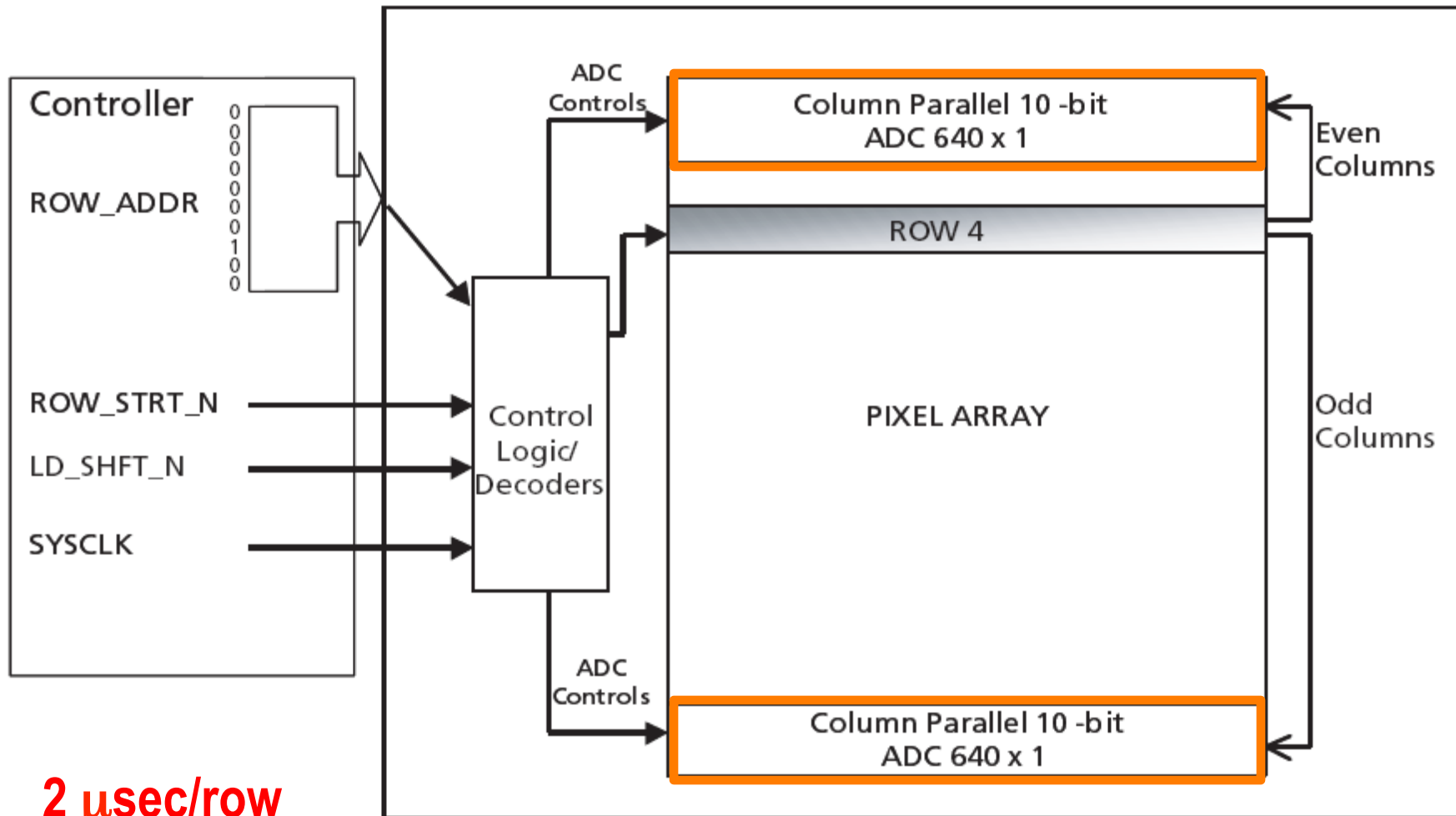

2 μ sec/row
2 msec/frame

R
(10 bits, 66MHz)

Photron SA-5 CMOS Camera



FRAME RATE (fps)	MAXIMUM RESOLUTION	
	Horizontal	Vertical
1,000	1,024	1,024
2,000	1,024	1,024
4,000	1,024	1,024
5,000	1,024	1,024
7,000	1,024	1,024
7,500	1,024	1,000
9,300	1,024	800
10,000	1,024	744
15,000	960	528
20,000	832	448
30,000	768	320
50,000	512	272
75,000	320	264
100,000	320	192
150,000	256	144
300,000	256	64
420,000	128	64
525,000	128	48
775,000	128	24
930,000	128	16
1,000,000	64	16

Gold nano particle (40nm) attached to Transferrin Receptor (TfR) on Cancer Cell

Prof. Manuel Penichet (Oncology)

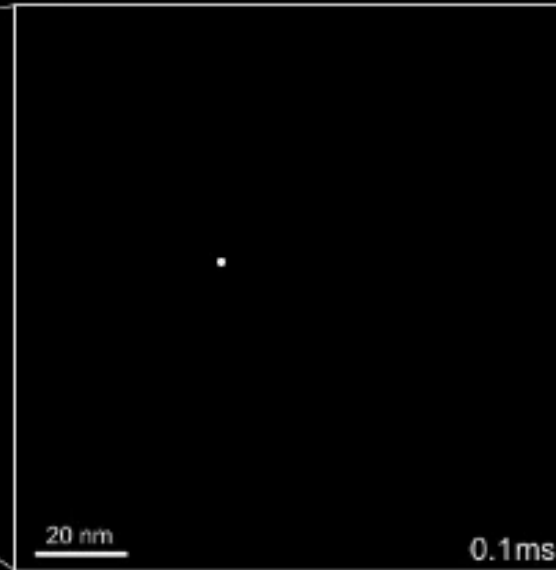
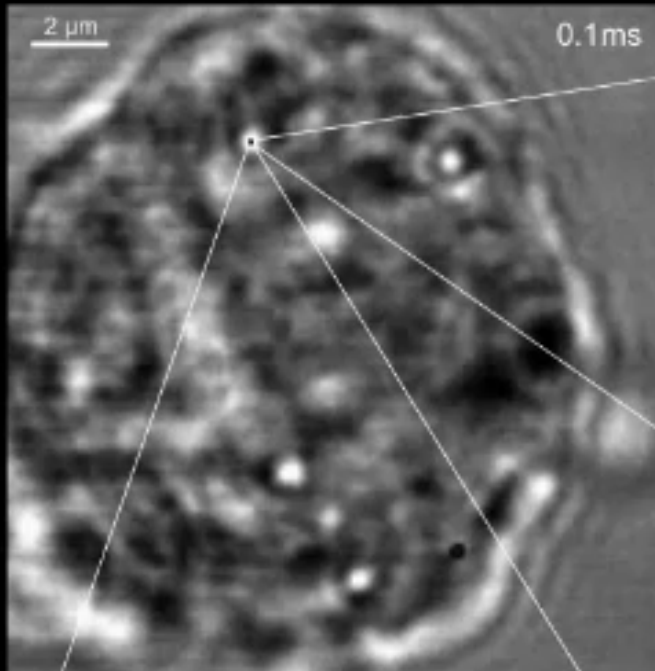

(10,000 frame/sec)

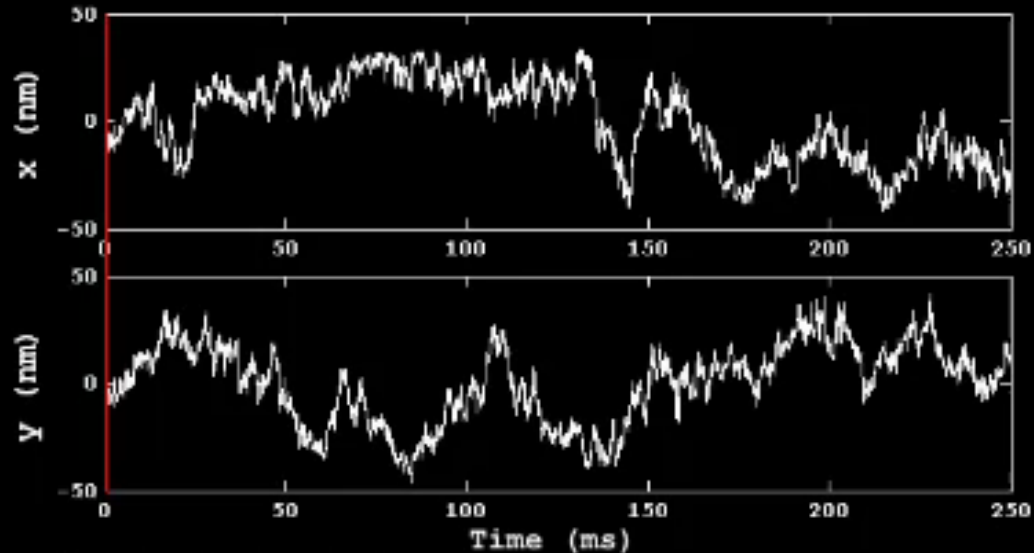
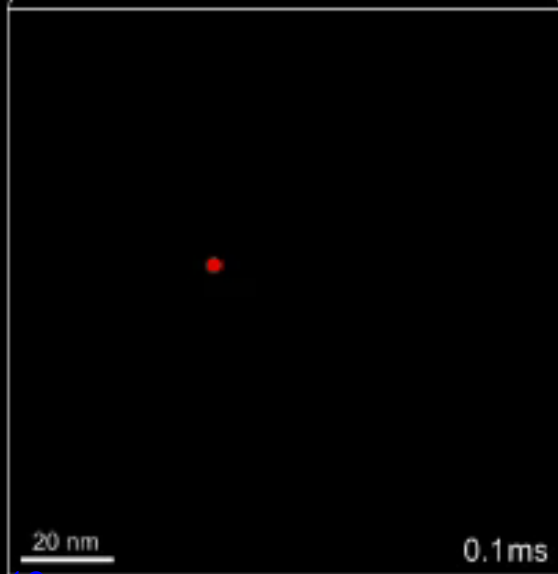

UCLA Fast Bio-Imaging Group

L. Fredriksson, A. Rodriguez, C. A. Cheng, K. Jewhurst, J. Miao, K. Arisaka

Mean Squire Displacement $\langle r^2 \rangle$ of TfR on a Human Multiple Myeloma Cell vs. Time

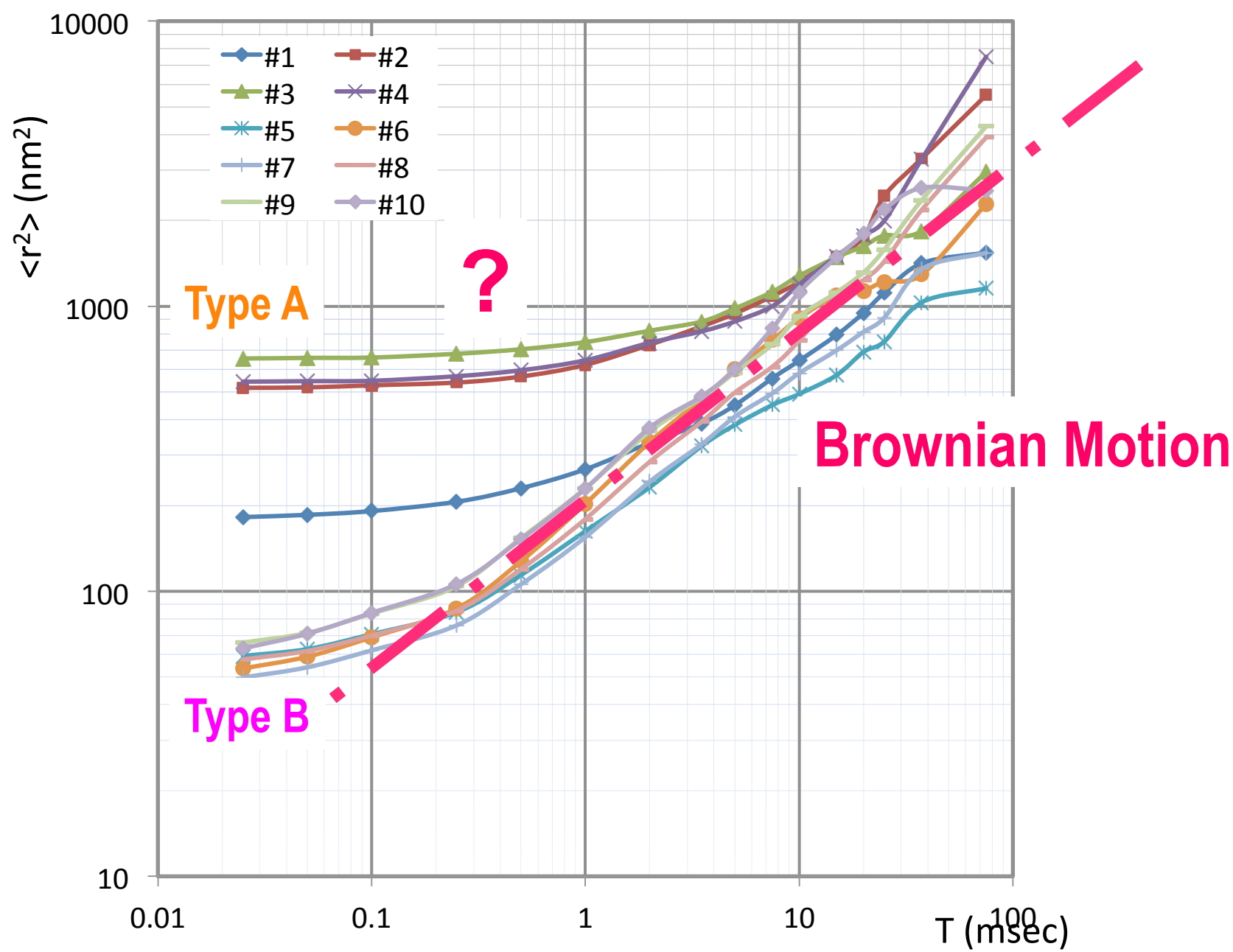

Arisaka's Campus-wide Collaborations on High-Speed Bio-imaging

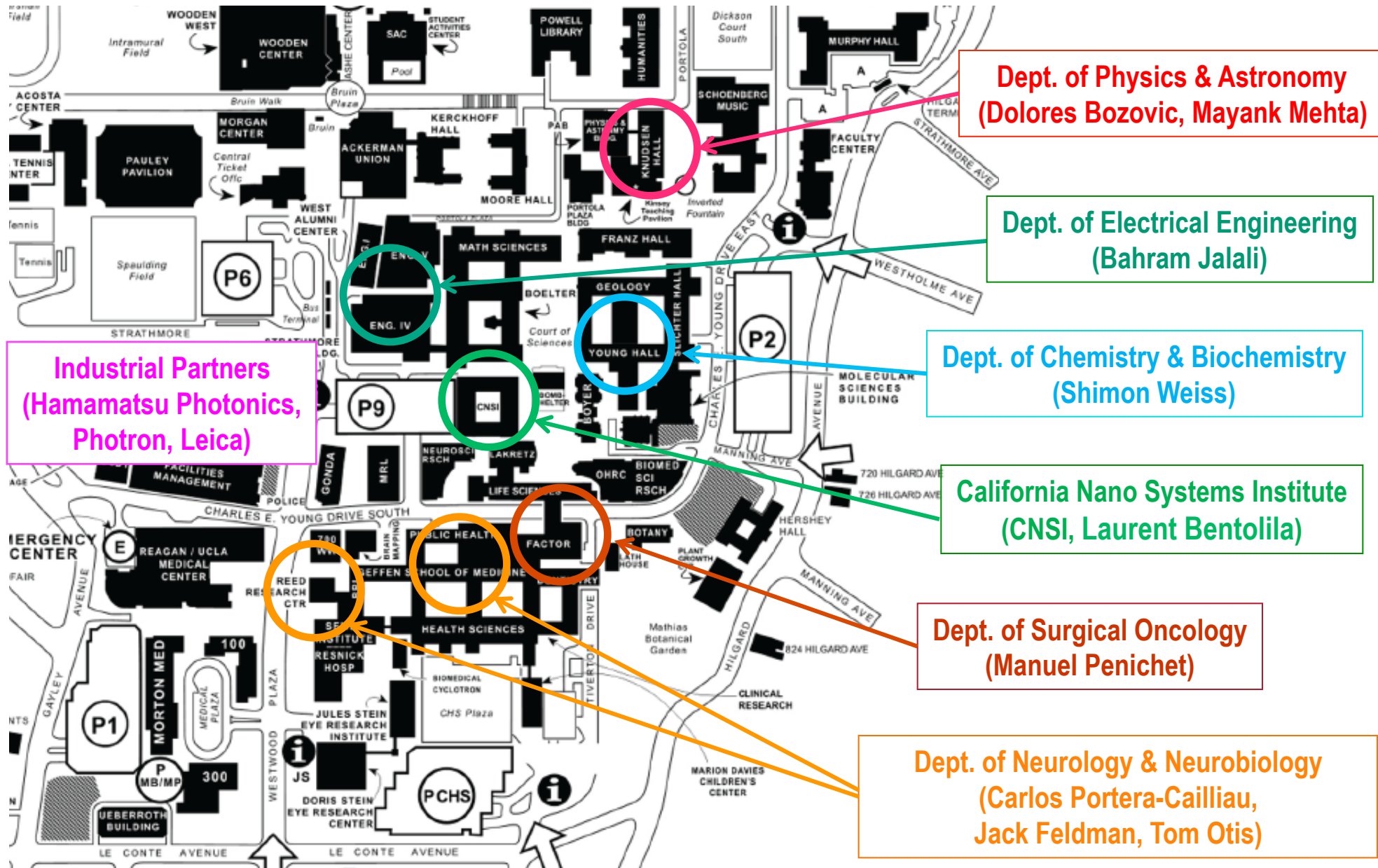

User-shared Core Facility of High-speed Microscopes at CNSI



4D Nano Biophysics

Nikon Microscope TE200E with TIRF at CNSI

Laurent Bentolila (CNSI)

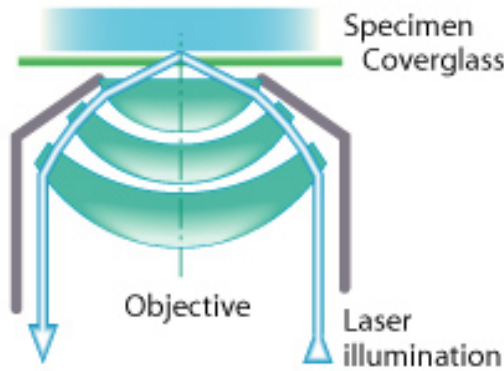
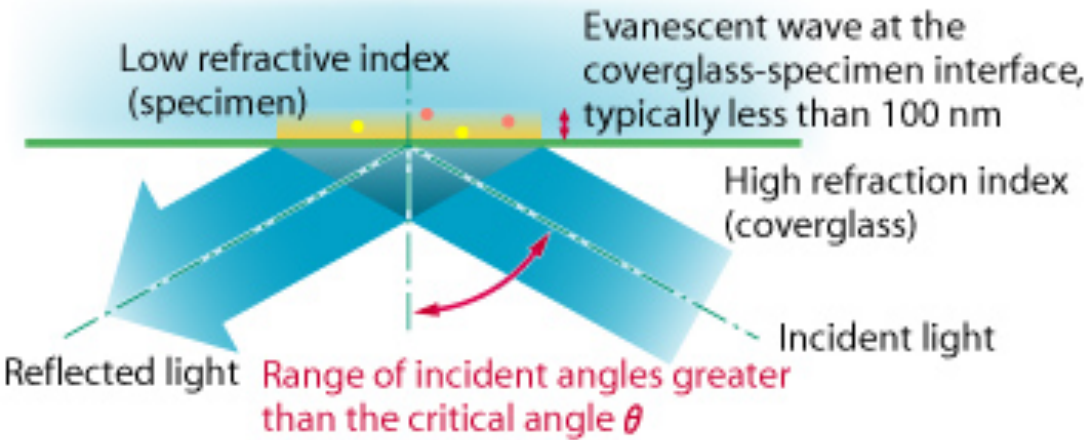

5k – 500k fps



CMOS Camera
Photron SA-1

Principle of ICMOS

Photron

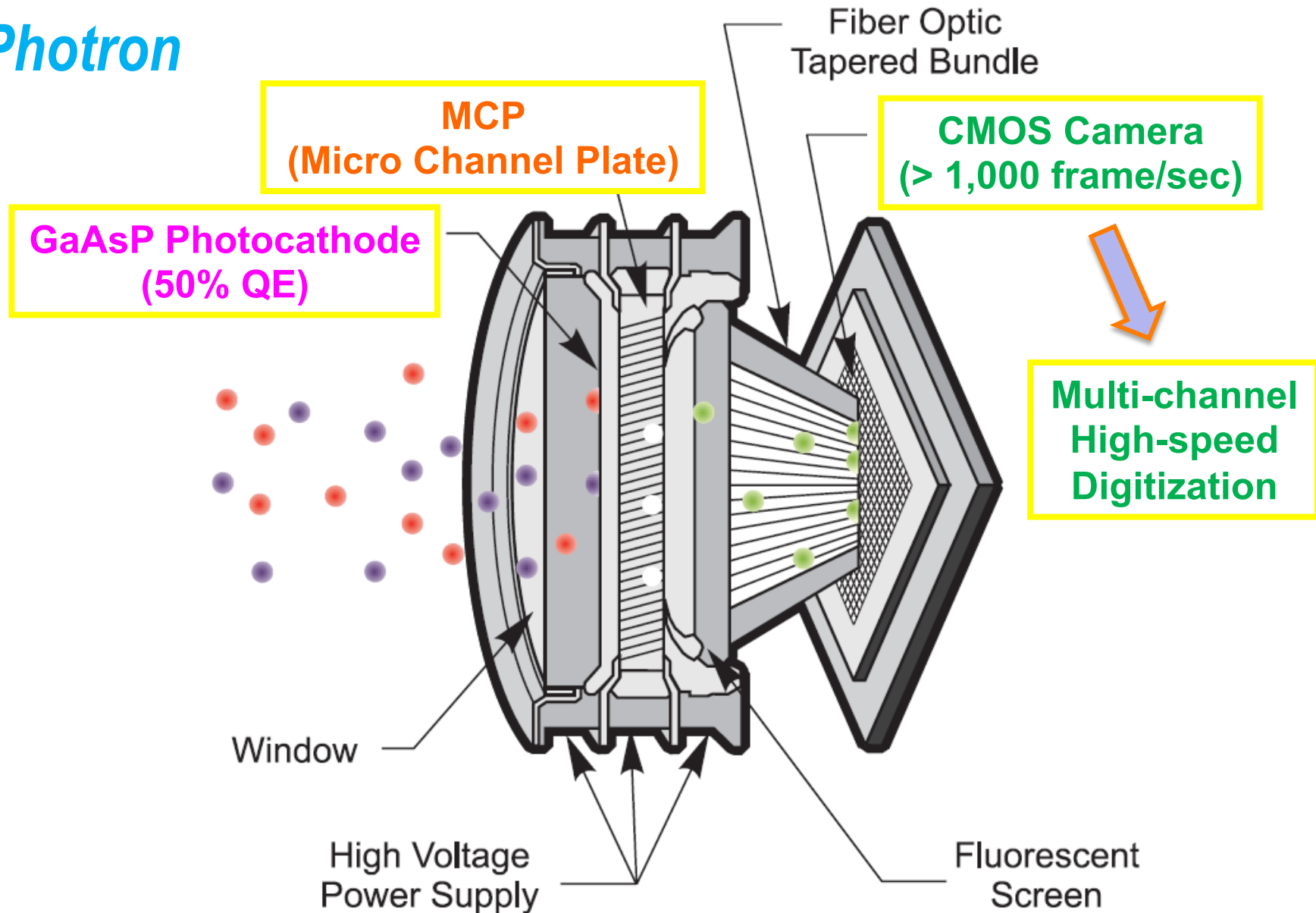

MCP (Micro Channel Plate)

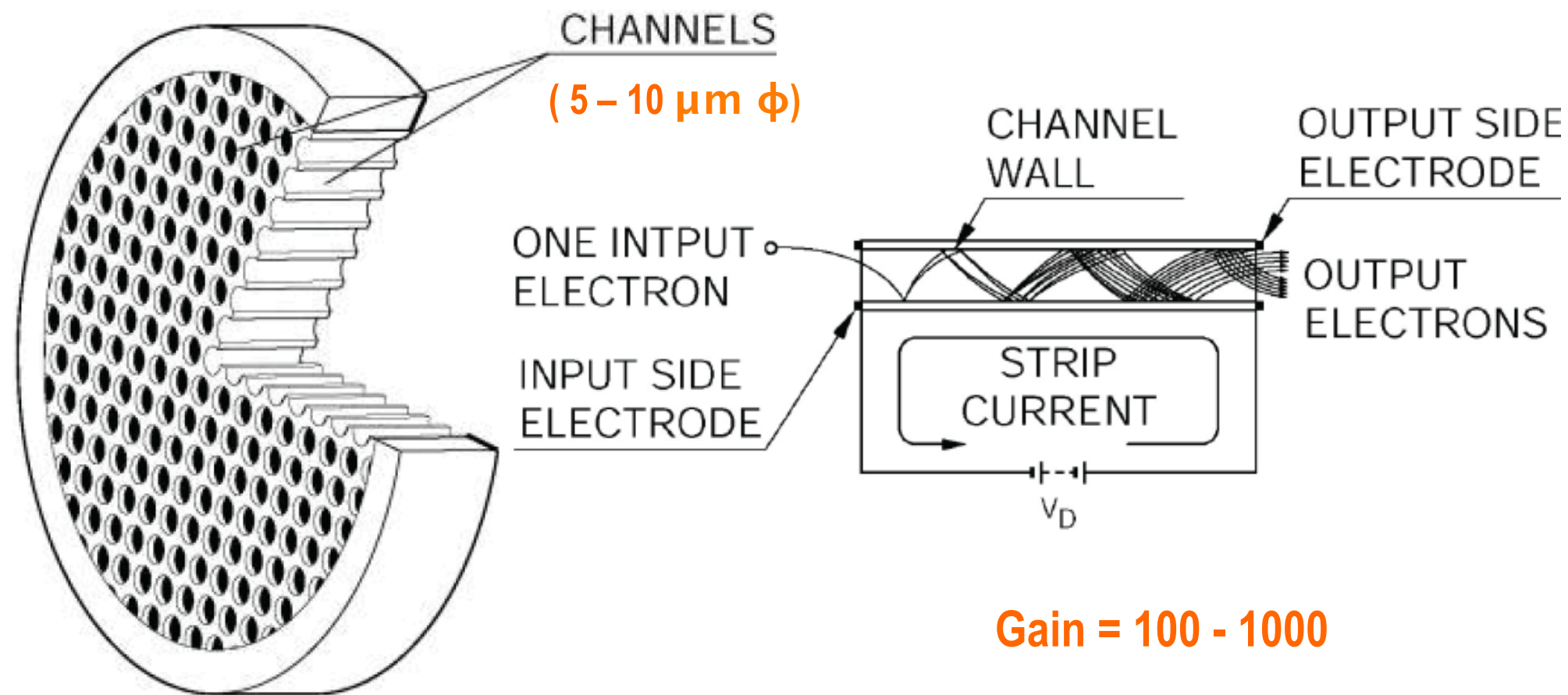

Gain = 100 - 1000

High-speed Confocal Microscope with ICMOS at CNSI

(1,000 frame/s)

ICMOS Camera
(Photron SV200i)

Leica Microscope

EMCCD Camera
(Ando iXon 897)

Confocal Spinner
(Yokogawa CSU-X1)

Laurent Bentolila (CNSI)

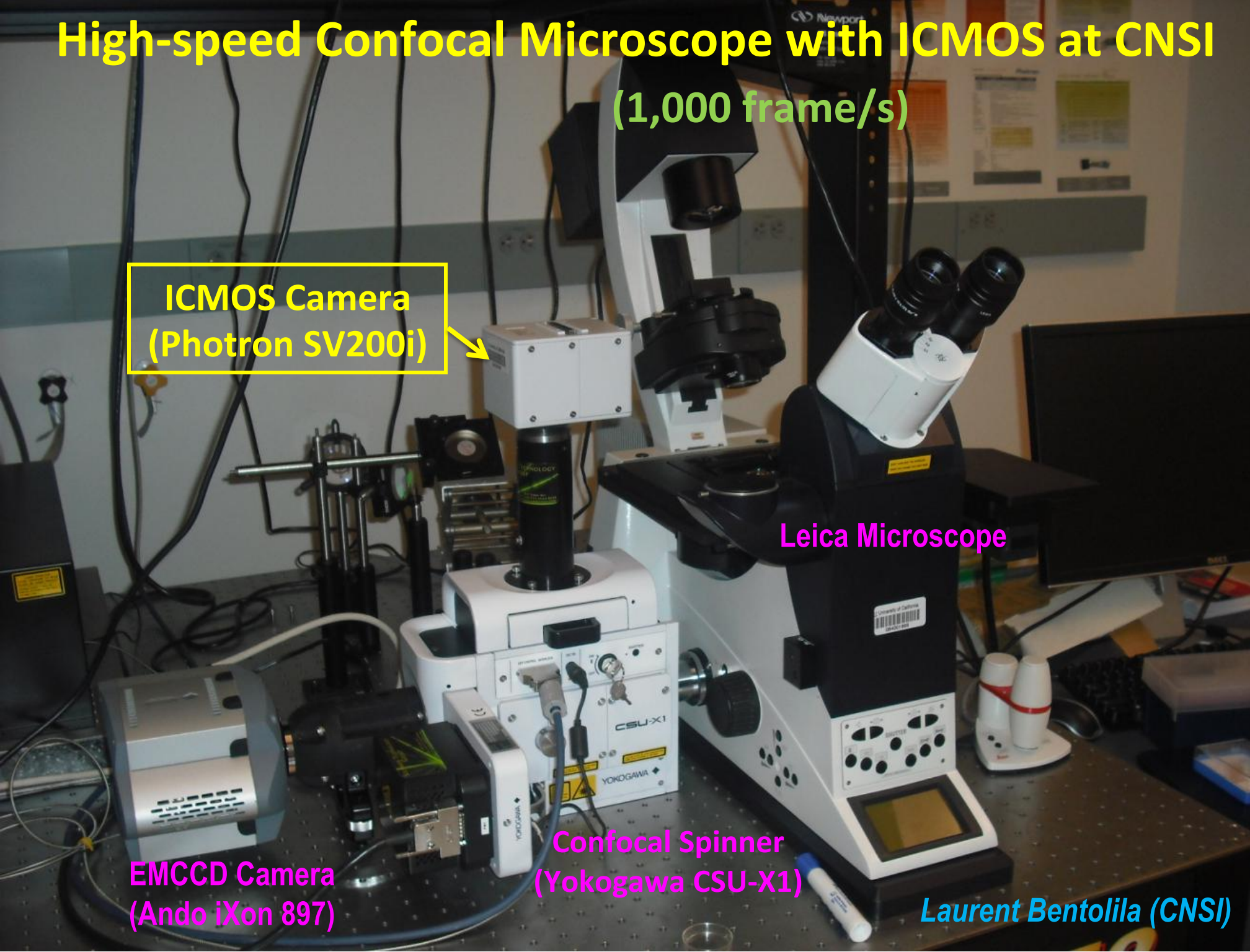

Yokogawa CSU-X1

2,000 fps

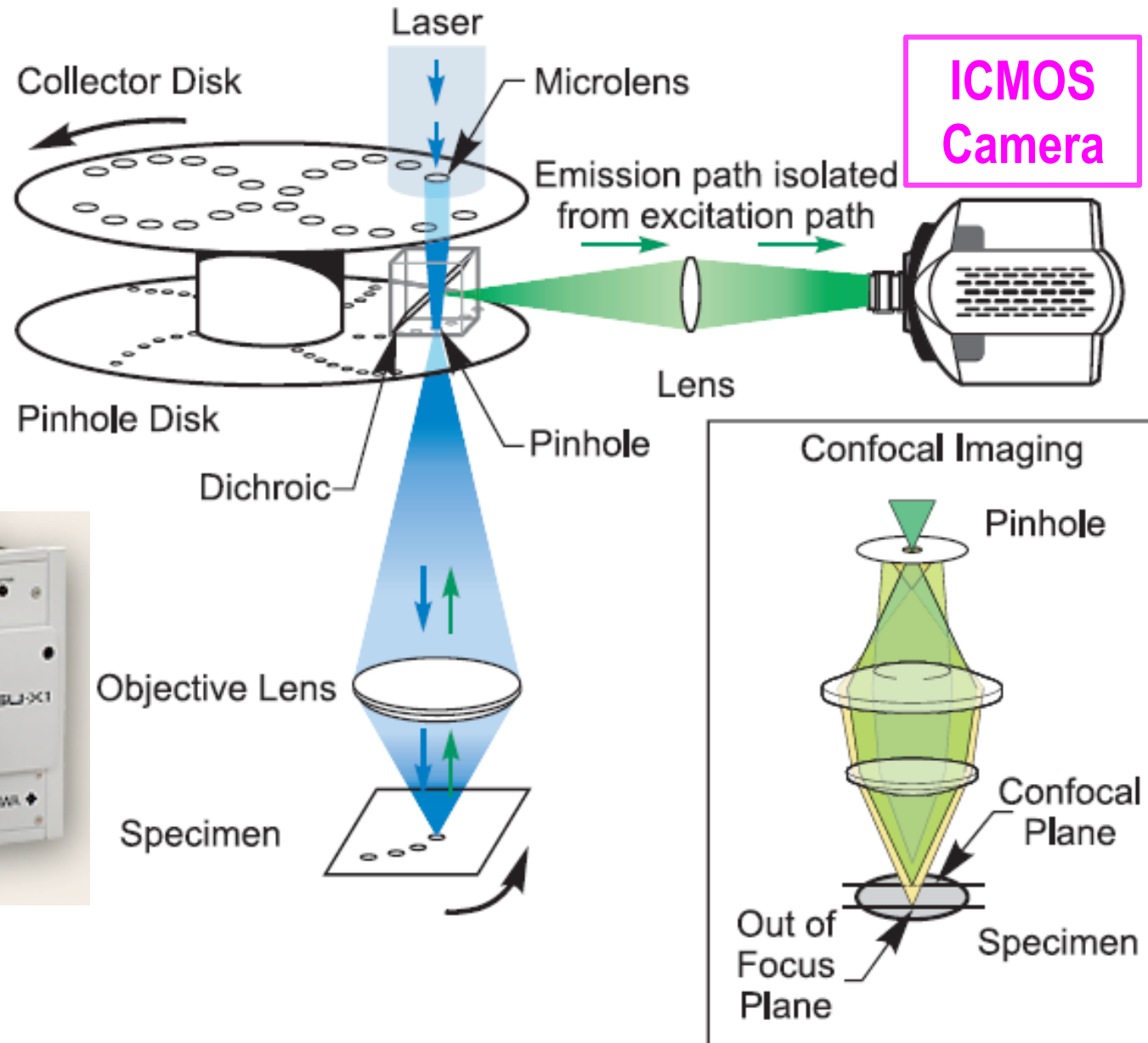

Confocal Dual Spinning Disk

Frame Rate vs. Resolution

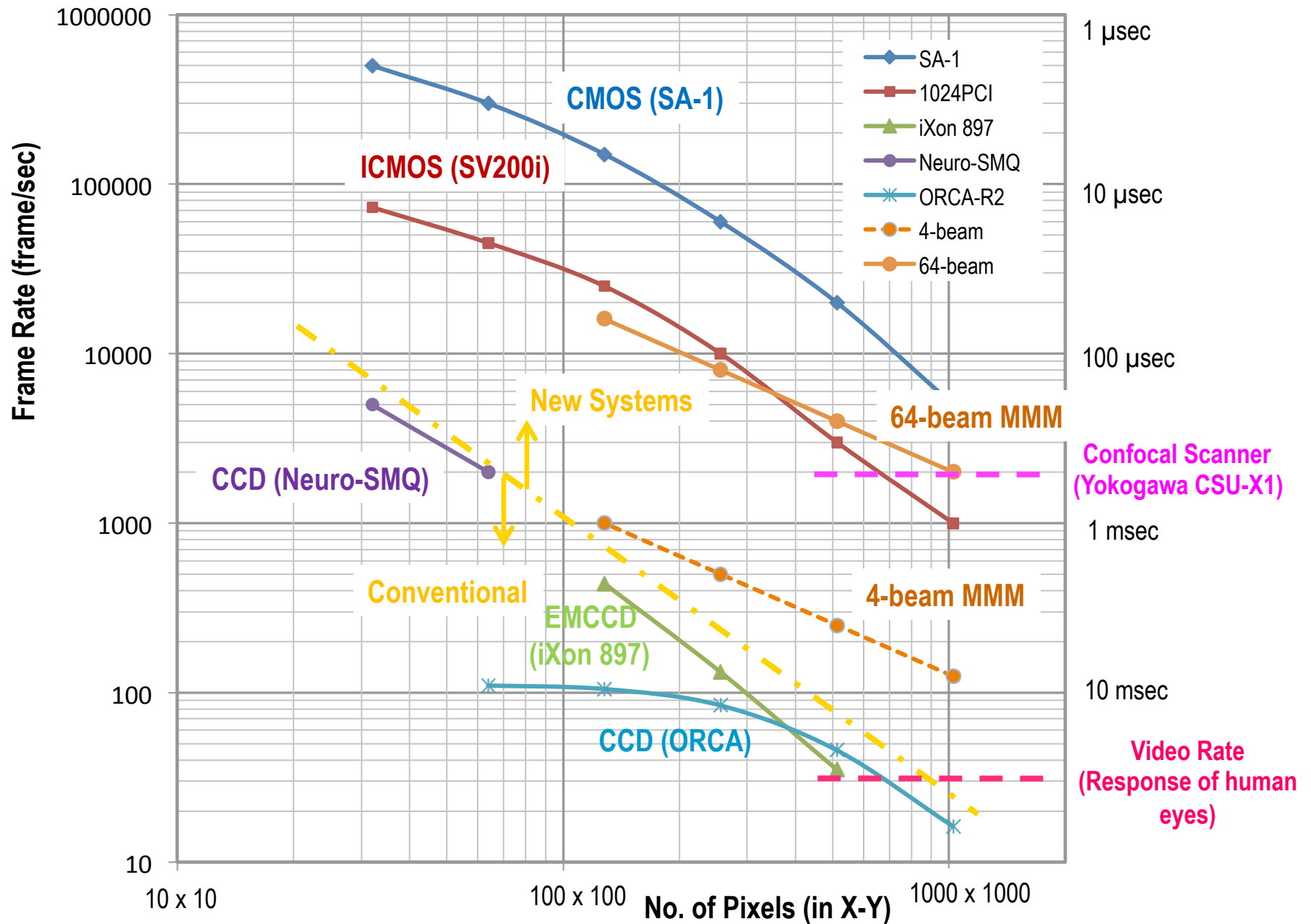

E2V-Caeleste scientific-CMOS (in development)

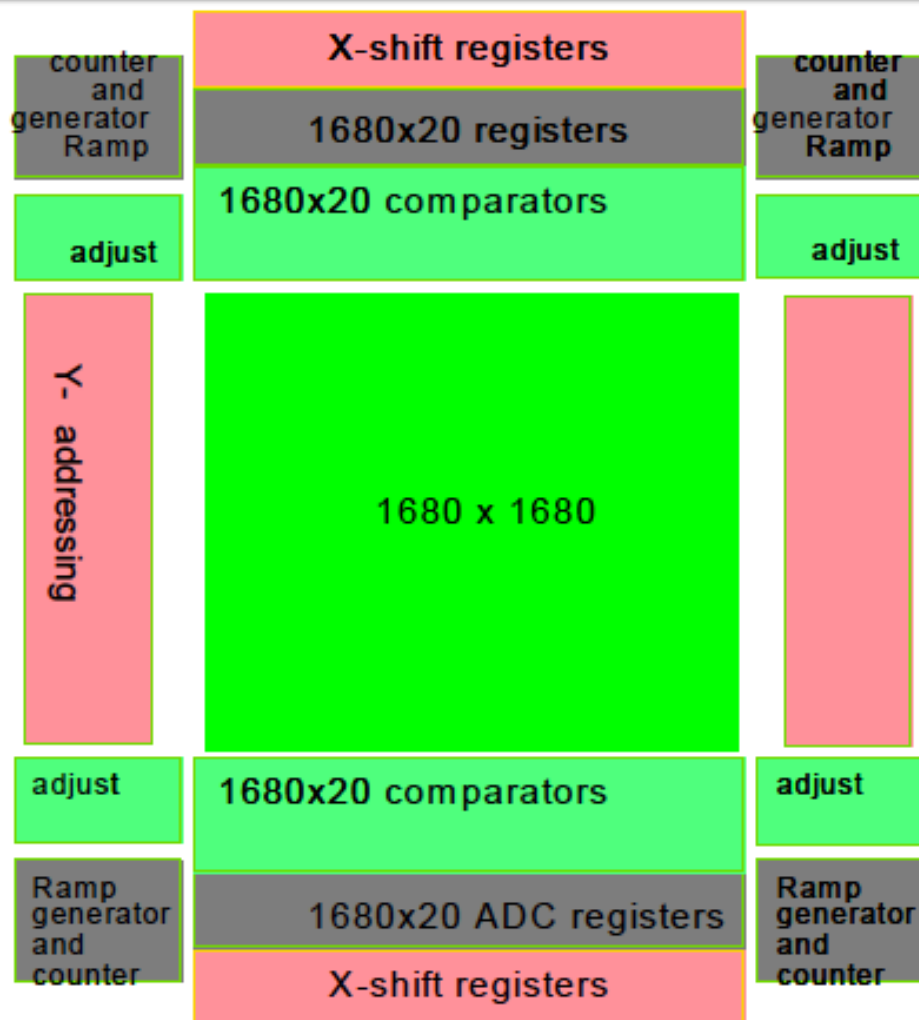

- ⇒ Foorplan of the full size sensor
- ⇒ Size is about 7x5cm
- ⇒ Max 1000 fps
- ⇒ Operating at 26Gbps
- ⇒ With over 68000 ADCs running in parallel
- ⇒ An ADC preamplifier gain adjustable per group of pixels
- ⇒ And with a noise level of less than 3 electrons_{RMS}
- ⇒ Electronic shutter: rolling segments of local synchronous shutter
- ⇒ Packaging
 - ⇒ Peltier cooler
 - ⇒ > 300 pins

Origin of Consciousness

Brain

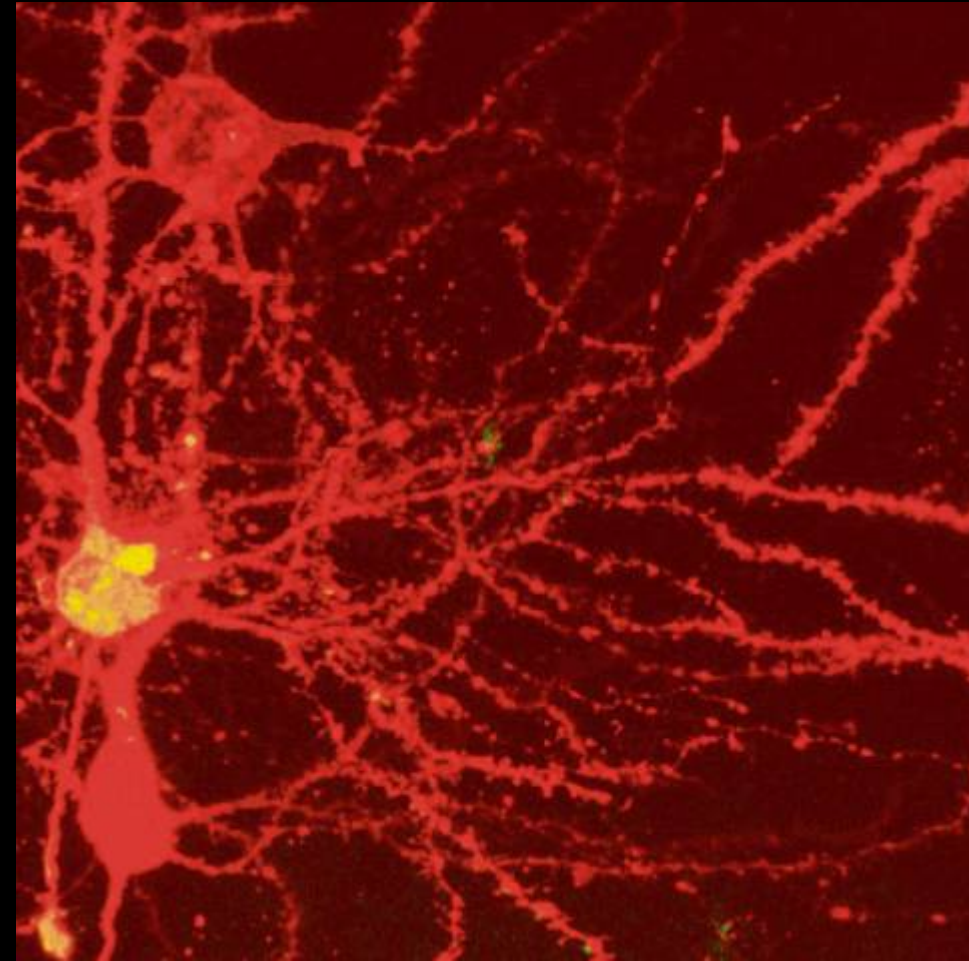

100 Billions Neurons

Universe

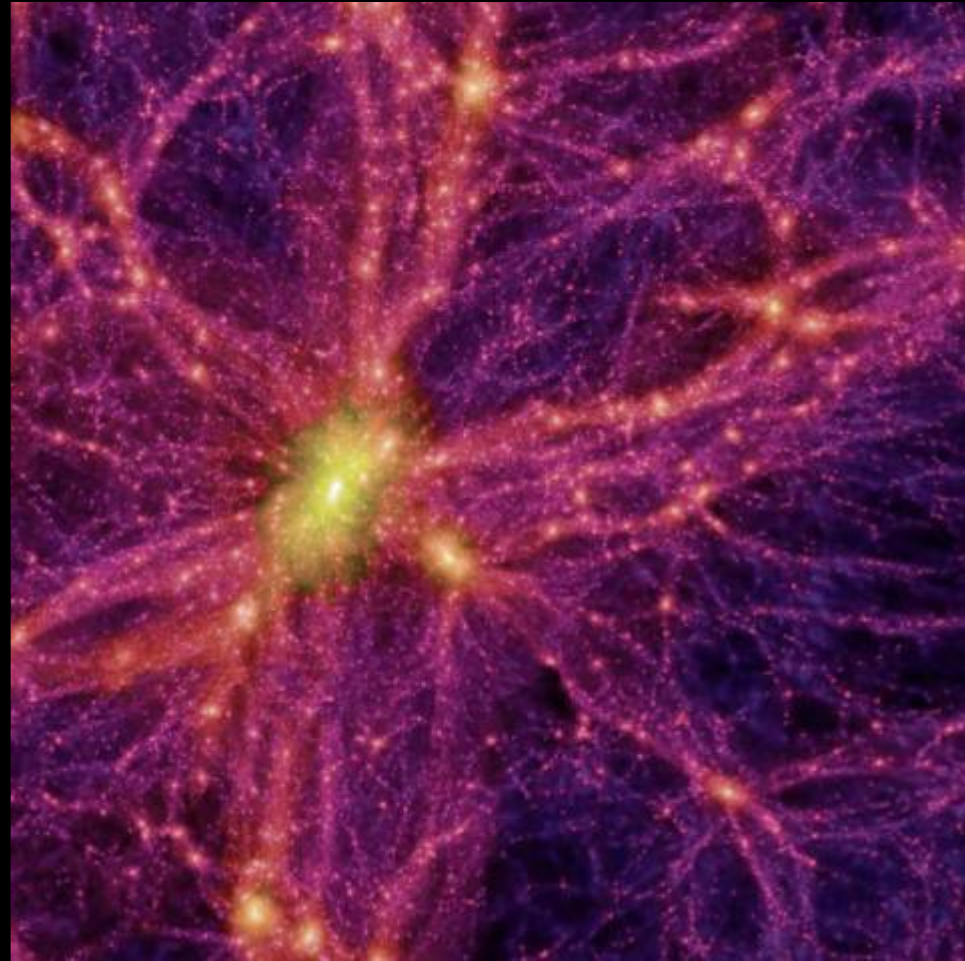

100 Billions Galaxies

Ca²⁺ Signal in cultivated Rat's Brain by Confocal Microscope

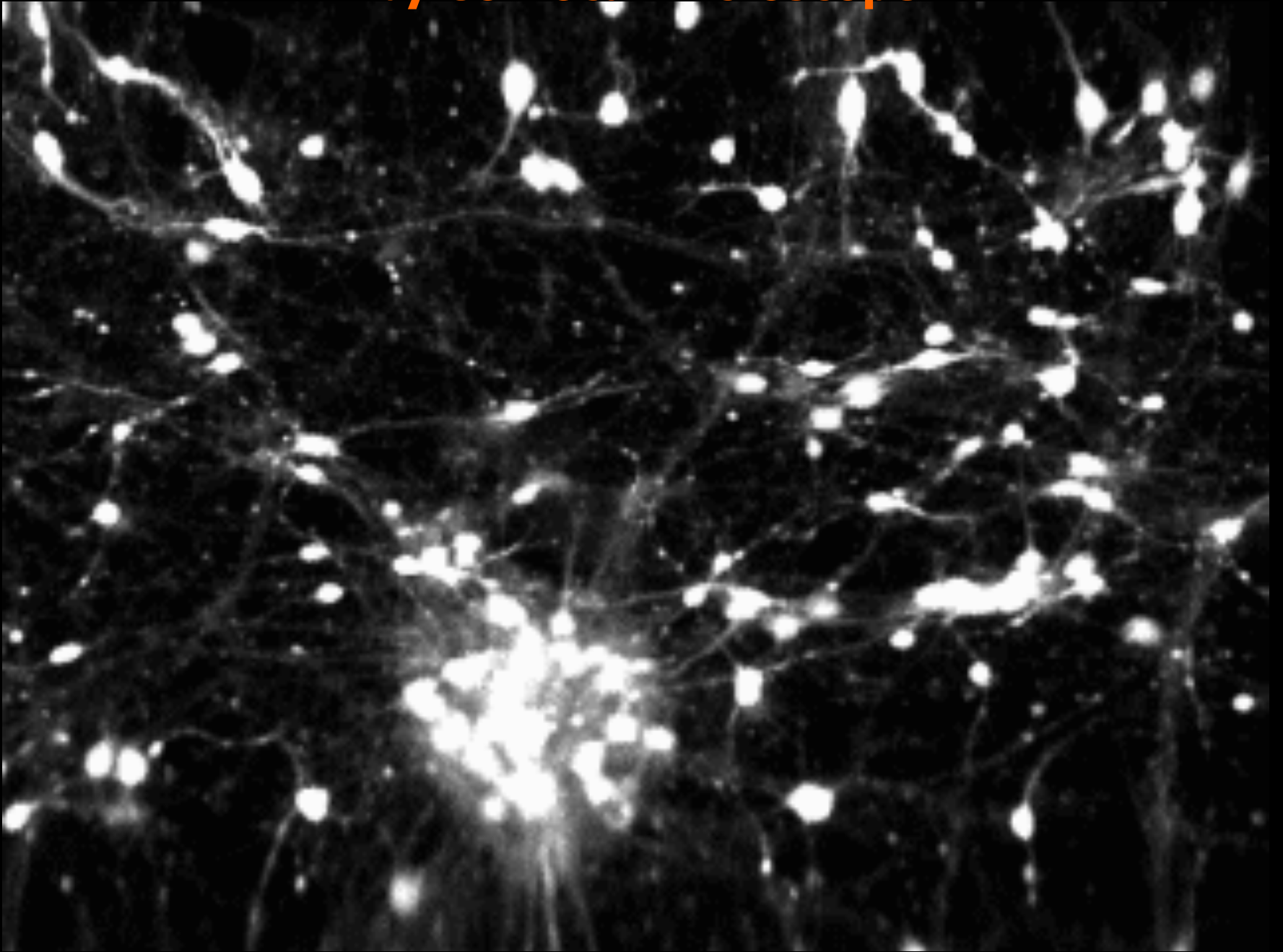

Andrew Charles (Neurobiology)

15 frame/sec

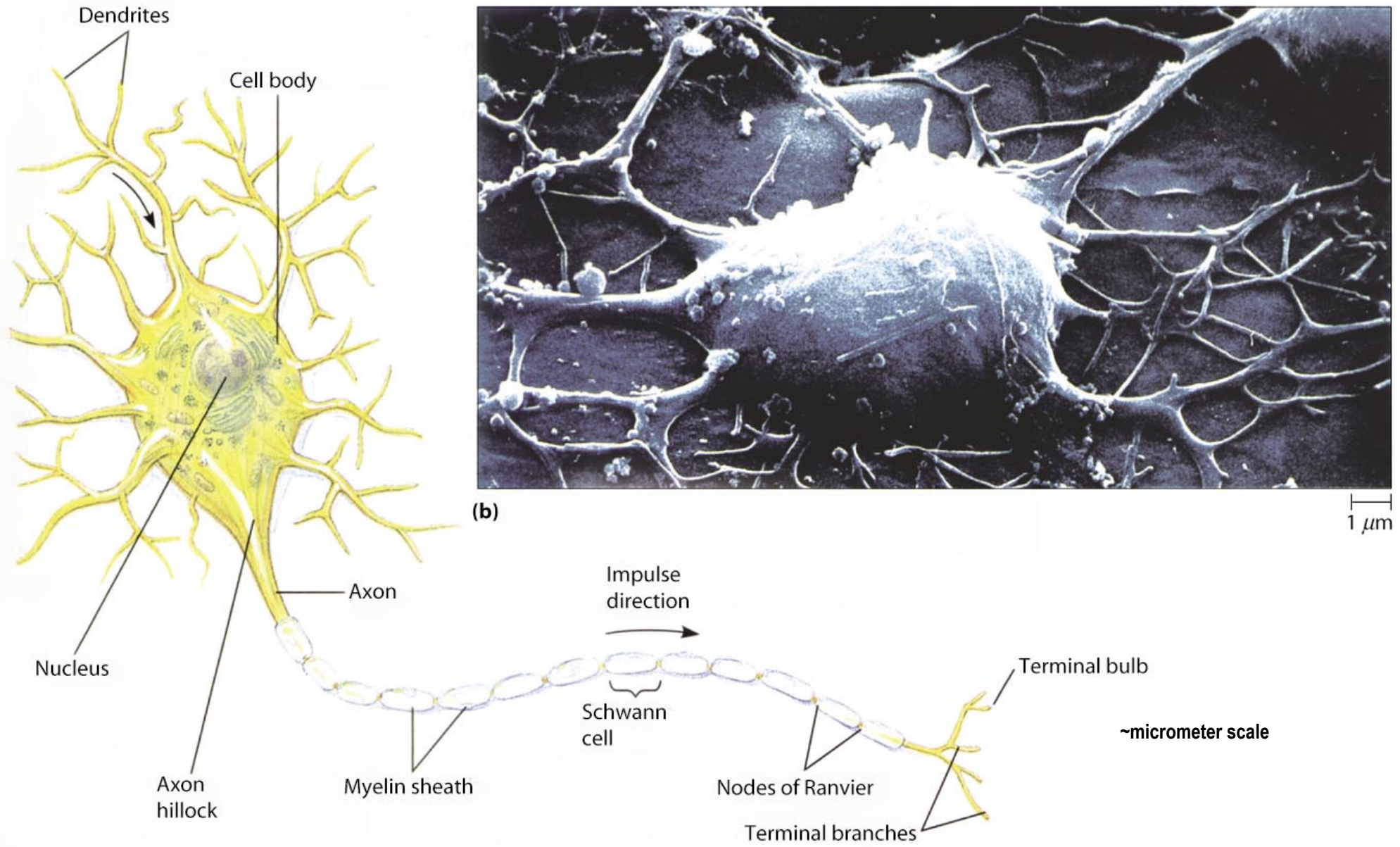

Neurons

Each Neuron has ~1,000 connections ($10^{11} \times 1000 = 10^{14}$)



IBM's Watson on 'Jeopardy!': The machine has won

February 16, 2011 | 9:11 pm

 (42)  (19)  Comments (2)



The machine has won.

Watson defeated the two biggest "Jeopardy" winners of all time: Ken Jennings and Brad Rutter.

The IBM computer finished the final round of competition on Wednesday night with \$77,147 in winnings over Jennings' \$24,000 and Rutter's \$21,600.

Jennings holds the record for number of consecutive Jeopardy matches won, with 74. Rutter has won more money than anyone else on Jeopardy.

The two men competed against each other in a 2005 tournament that resulted in a Rutter victory.

Since Watson won, IBM is awarded \$1 million -- all of it going to charities [World Vision](#) (an anti-poverty group) and [World Community Grid](#) (which builds computer grids to address social issues such as water shortages).

Katsushi Arisaka, UCLA

“Moore’s Law” Transistors in Computer

Watson

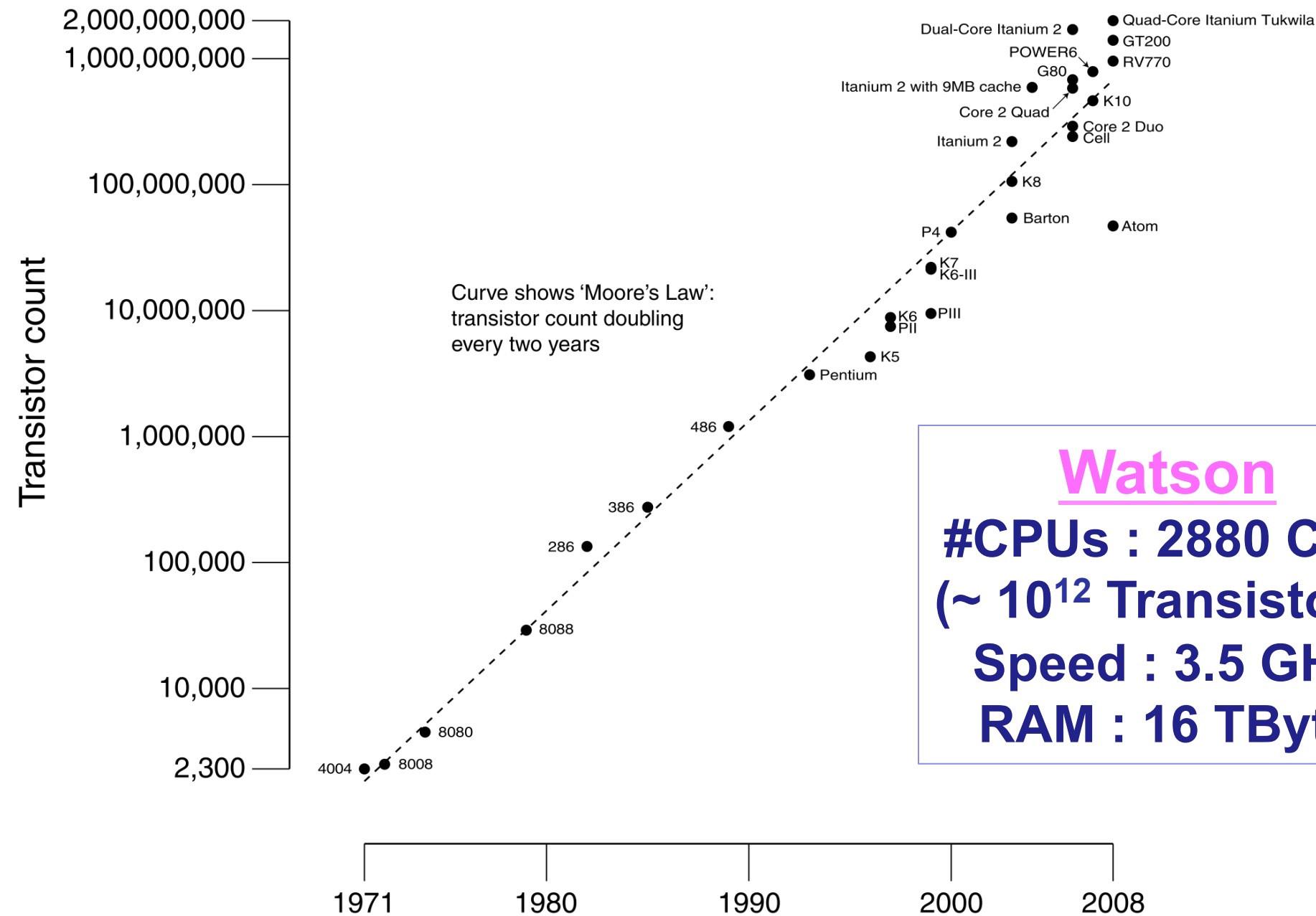

Watson
#CPUs : 2880 CPU
(~ 10¹² Transistors)
Speed : 3.5 GHz
RAM : 16 TByte

From No Brain to Big Brain



Paramecium (Single Cell)



Bullfrog ($\sim 10^7$ neurons)



Lymnaea ($\sim 1,000$ neurons)



Zebrafish ($\sim 10,000$ neurons)



Rat ($\sim 10^8$ neurons)

Neurons in Brain

Human

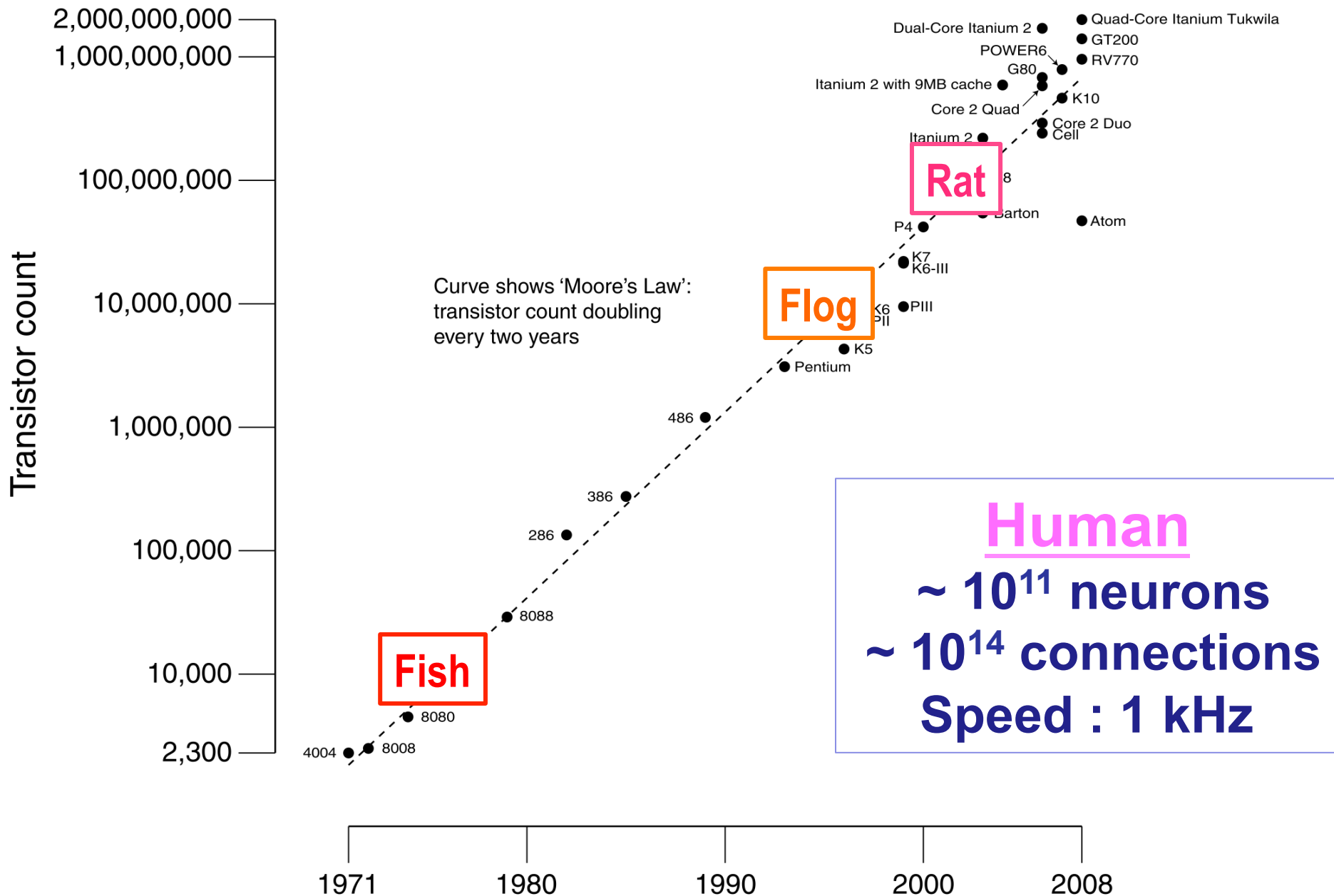

Computer vs. Brain

	Computer (Watson)	Human Brain
<i>Key Unit</i>	Transistor	Neuron
<i>No. of units</i>	$\sim 10^9$ ($\sim 10^{12}$)	$\sim 10^{11}$
<i>Connection</i>	Copper Wire	Axon + Dendrite
<i>No. of Connections</i>	$\sim 10^{10}$ ($\sim 10^{13}$)	$\sim 10^{14}$
<i>Signal Carrier</i>	Electrons	Ions (Na ⁺ , Ca ⁺ , K ⁺)
<i>Clock Speed</i>	~ 1 GHz	~ 1 kHz
<i>Method</i>	Sequential	Parallel Processing

Neural Networks for Breathing

~300 neurons in rat's brain (pre-Botzinger Cells) responsible for breathing

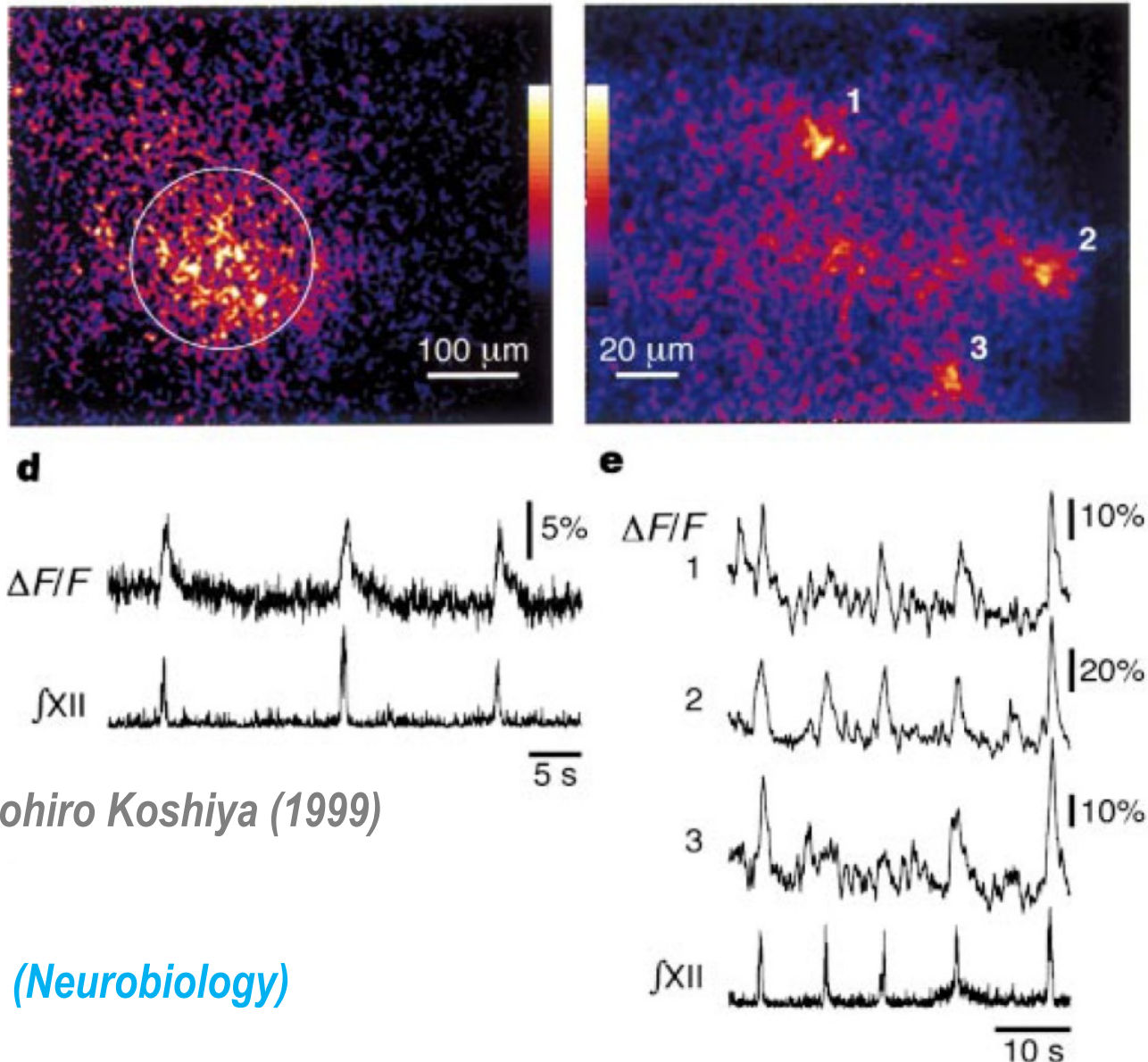

Nature by Naohiro Koshiya (1999)

Jack Feldman (Neurobiology)

High-speed Ca^{2+} Imaging of pre-Botzinger Cells of Rats

Prof. Jack Feldman (Neurobiology)

(1,000 frame/sec)

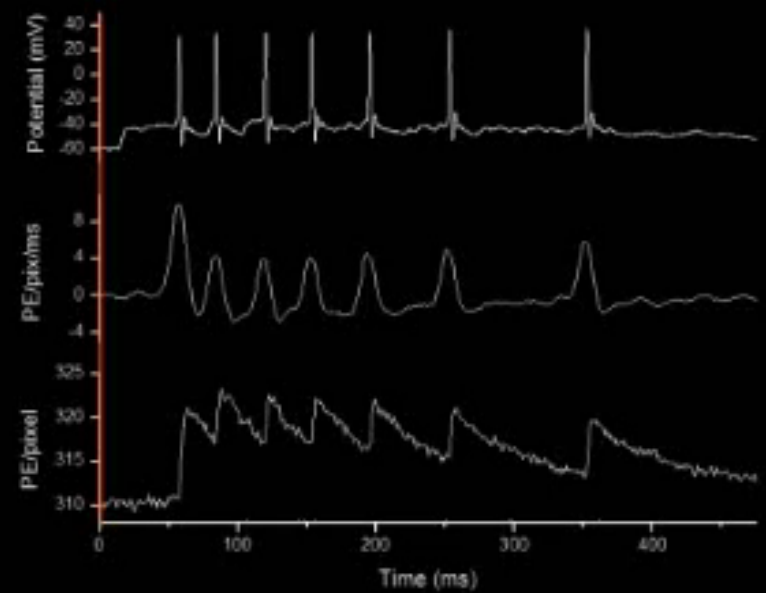
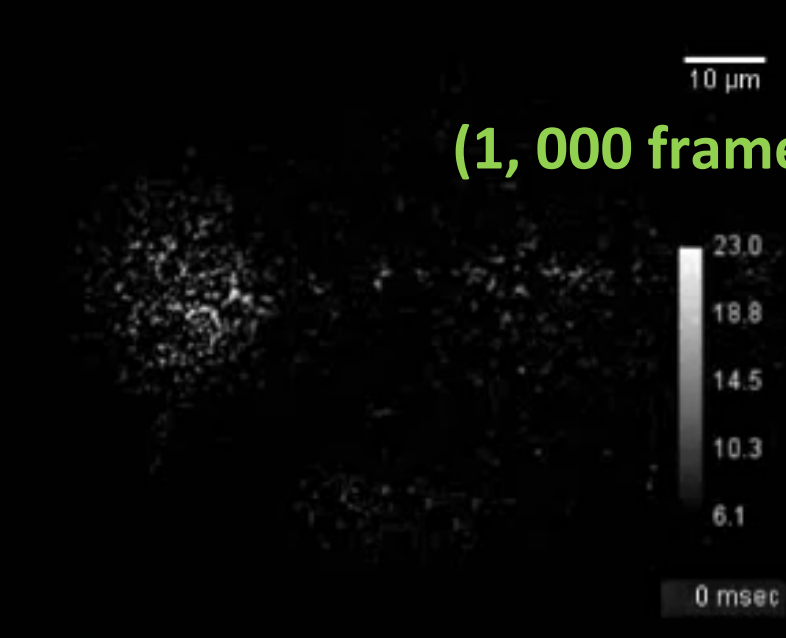

UCLA Ultra-fast Bio-imaging Group

C. Morgado, A. Cheng, L. Frederickson, K. Arisaka, J. Feldman

Sensory Input and Decision Making in Brain

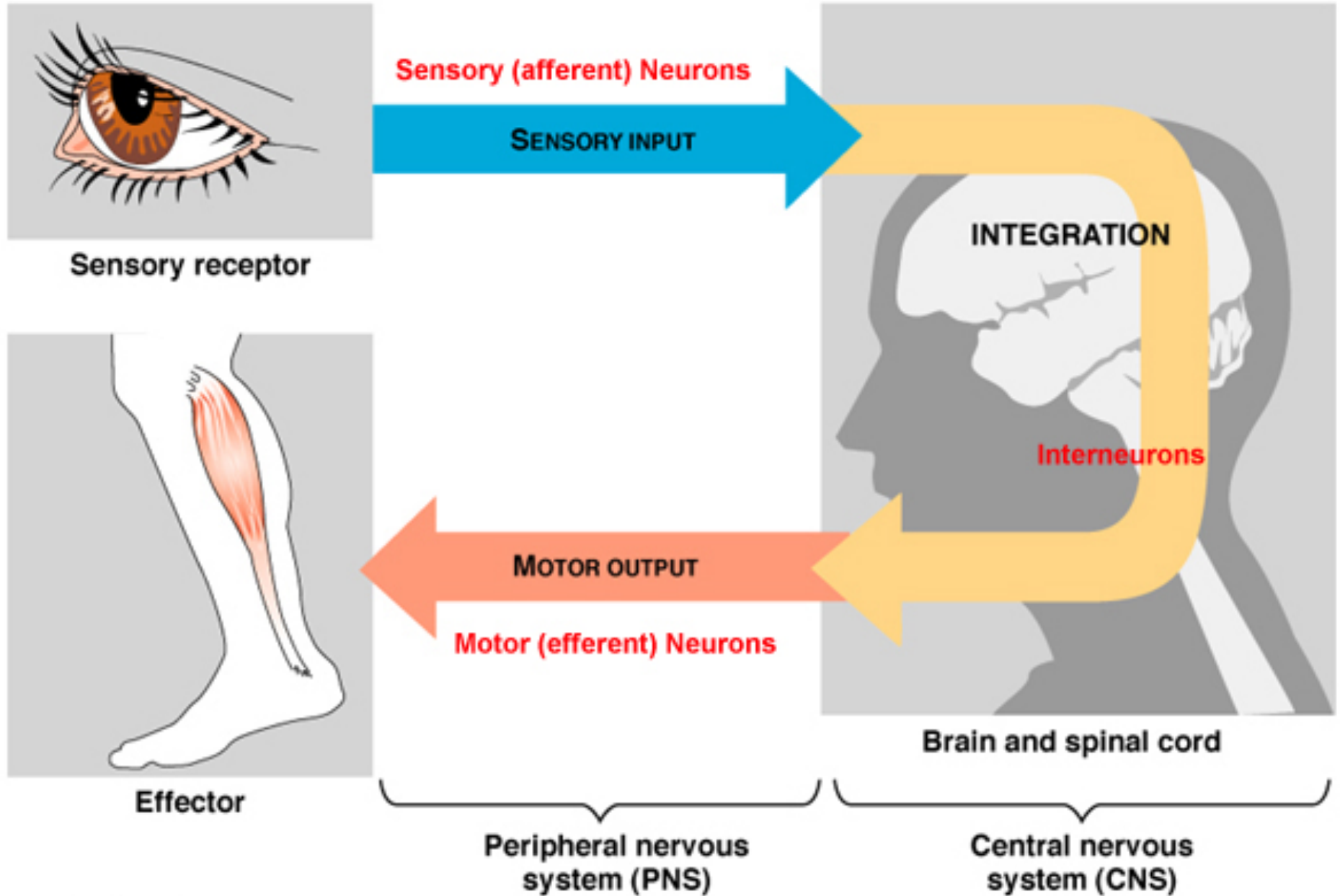

Human Eyes

~100M photo receptors

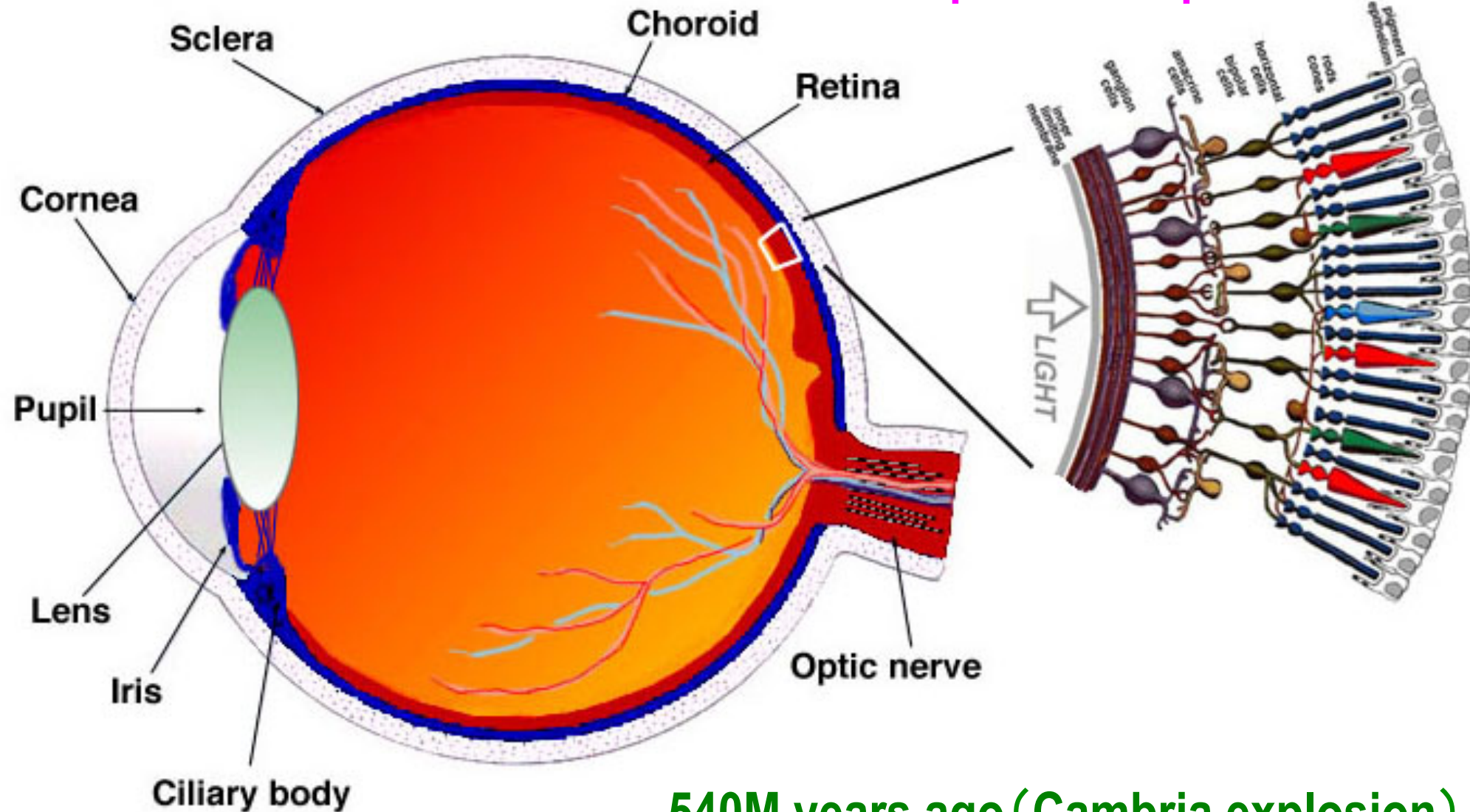

540M years ago (Cambria explosion)

Human Ears

~10,000 Hair Cells

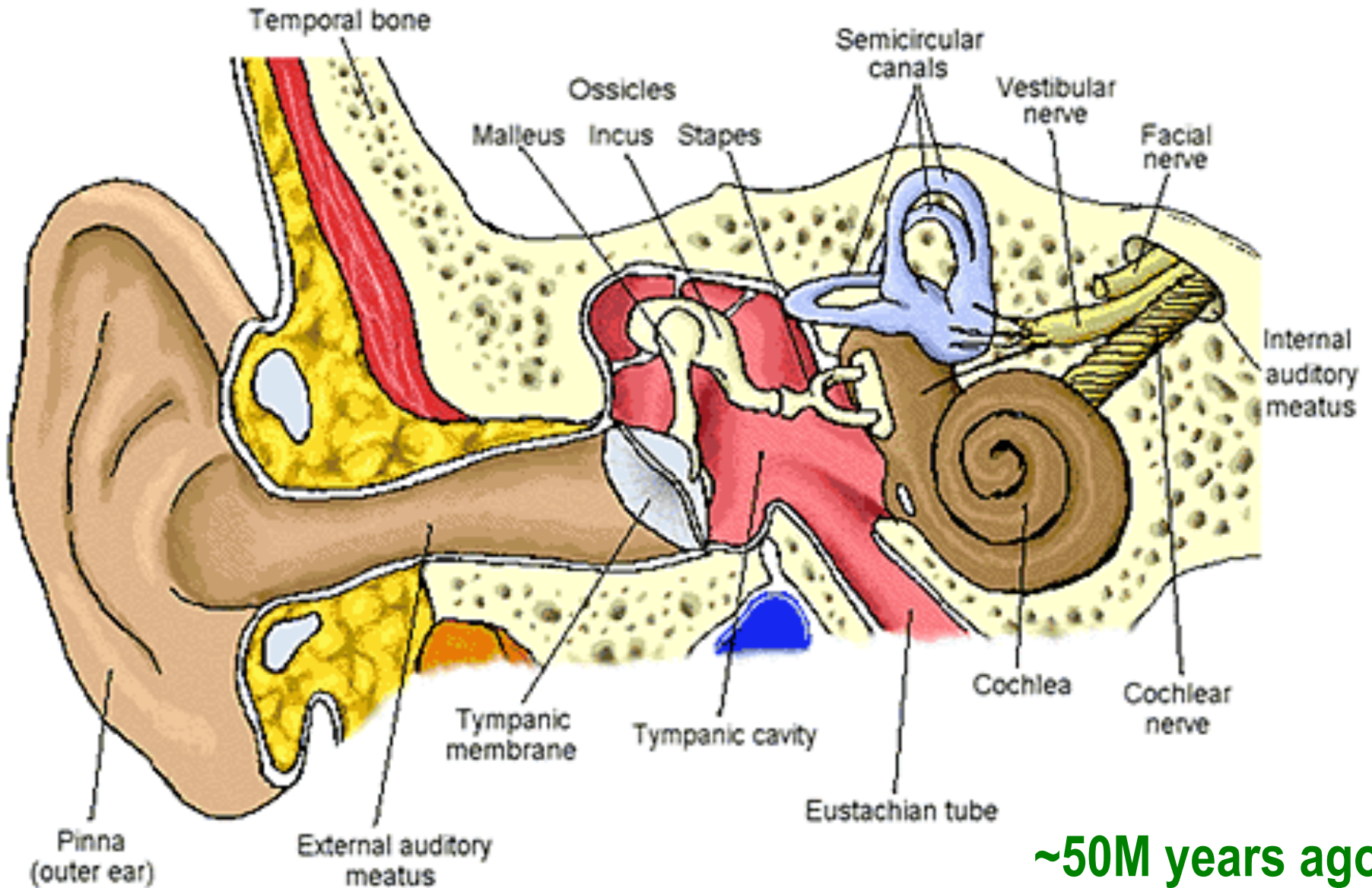

~50M years ago

Anatomy of Inner Ear

Dolores Bozovic (Physics)

Human auditory system

Cross-section of the cochlear

Hair bundle

Molecular mechano-transduction machinery

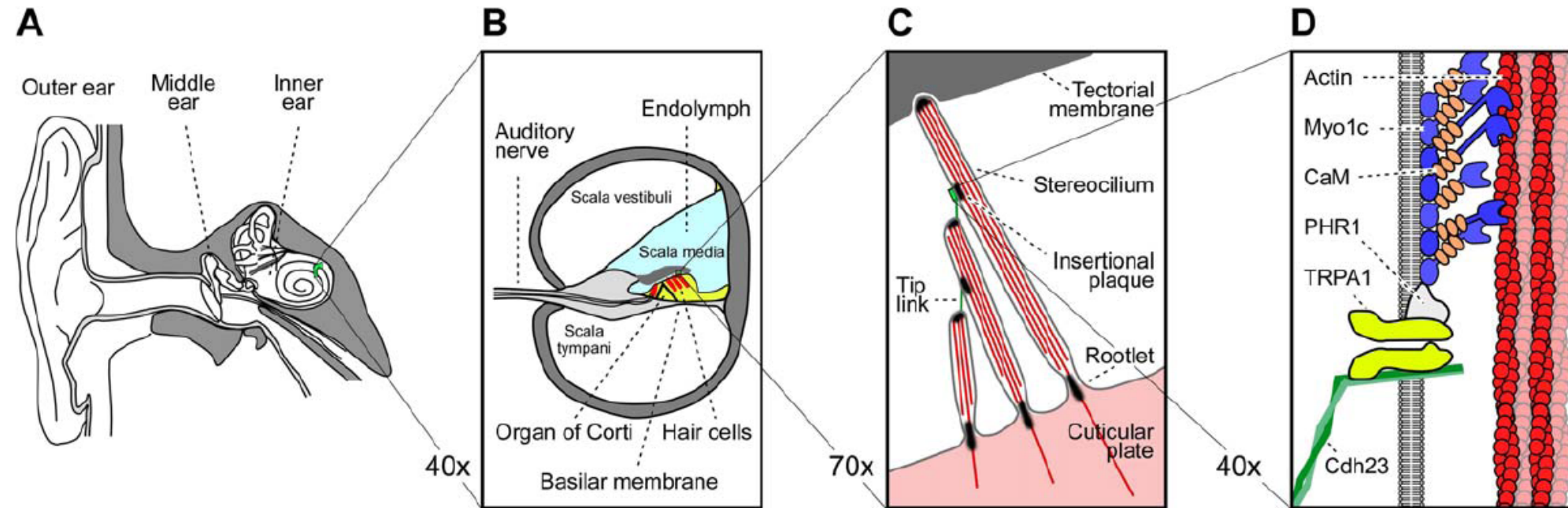

Meredith LeMasurier and Peter G. Gillespie, *Neuron*, Vol. 48, 2005

Simultaneous observation of entire process

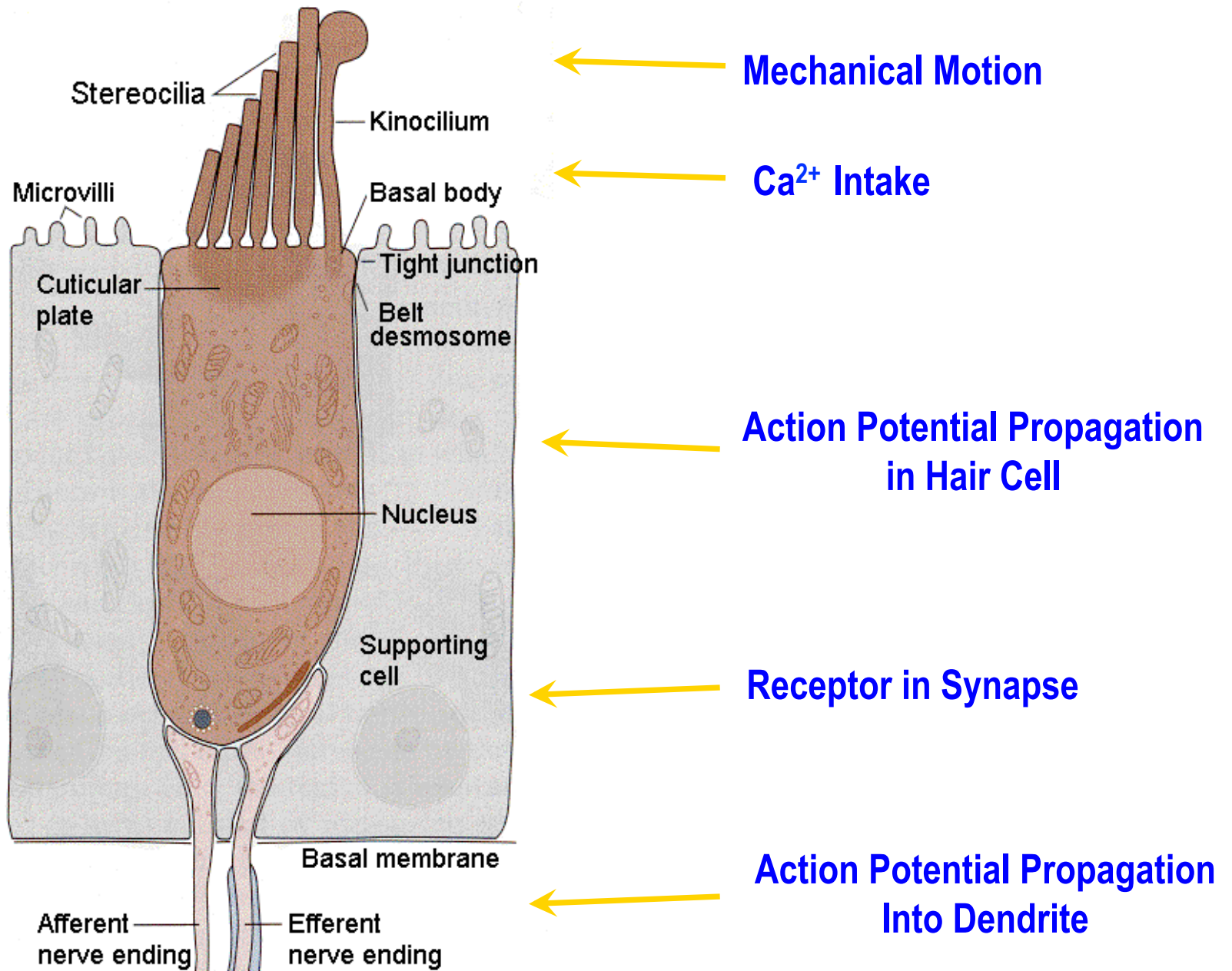

**CMOS Camera
(Photron SA-1)**

**EMCCD Camera
(Andor iXon 897)**

Microscopes

Objective

Dolores Bozovic's Lab (Physics)

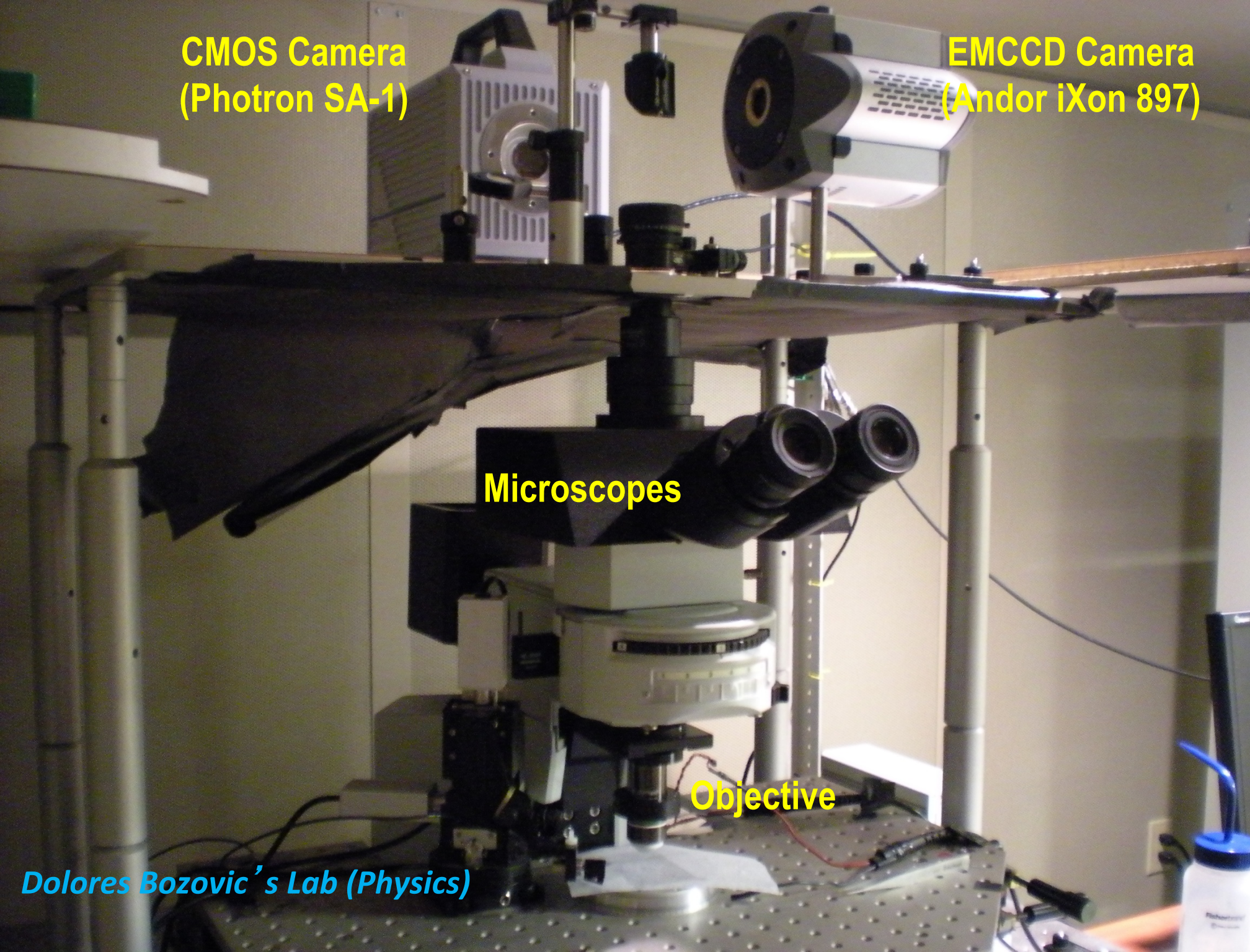

Mechanical Motion of Hair Cells in Inner Ear

Prof. Dolores Bozovic (Physics)

(1,000 frame/sec)

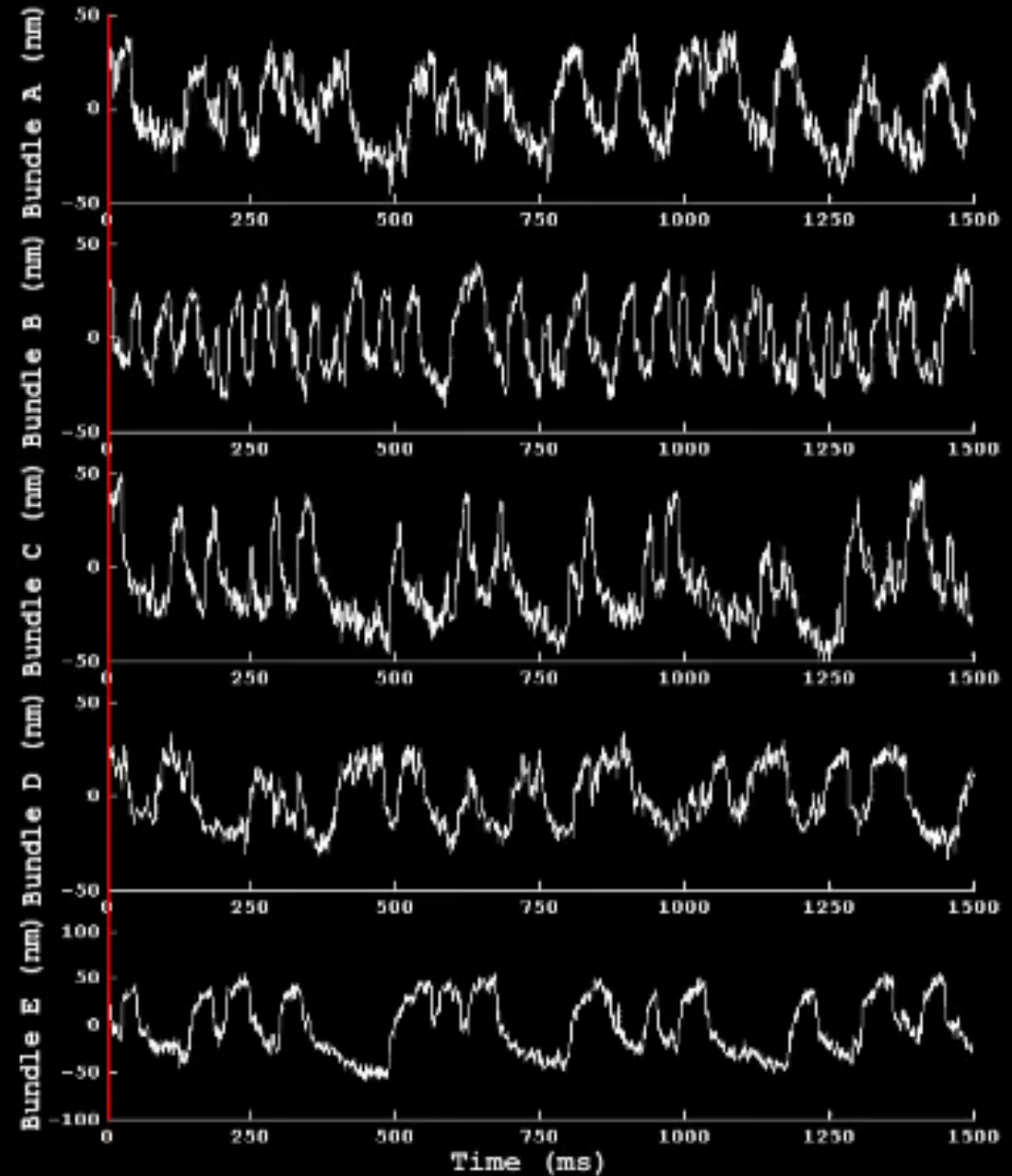
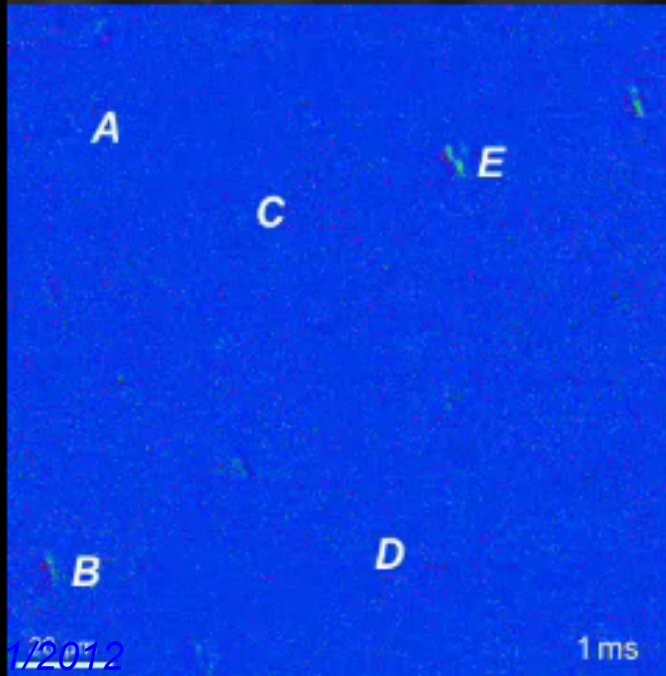
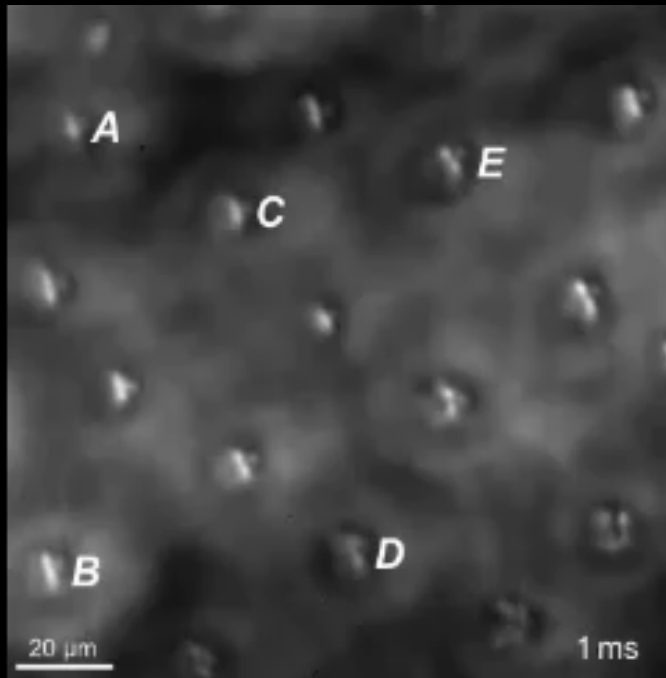

UCLA Fast Bio-Imaging Group

L. Fredrickson, A. Cheng, J. Jewhurst, C. E. Stimbu, D. Bozovic, K. Arisaka

Mystery of Hearing

- **Extremely wide dynamic range in amplitude.**
 - 10^6 compressed to 100
 - Smallest amplitude is 0.3 nm
- **Extremely wide frequency range.**
 - 20 Hz – 20 kHz
 - Dynamic range of 1000
 - Corresponding to 10^6 in k
 - **Selectivity of 0.2%**
 - up to 5 kHz
 - **How can the brain handle up to 20 kHz?**
 - miss match to the speed of action potential of 1 kHz

$$\omega = \sqrt{\frac{k}{m}}$$

How can I recognize a woman so far away?



- Genetically encoded?
- Learning and memory?

Nature vs. Nurture

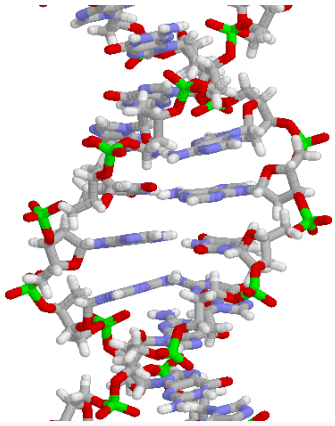

Nature

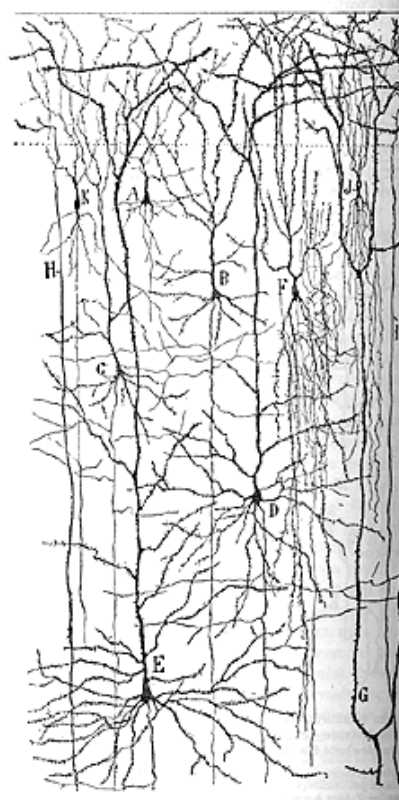

Nurture

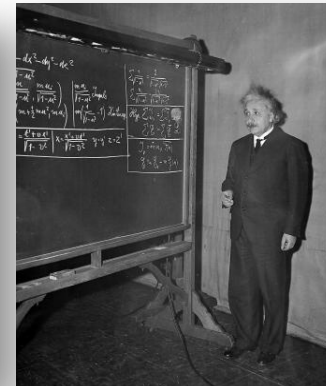
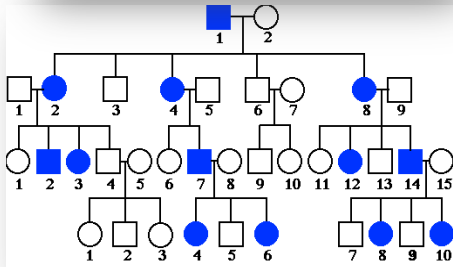
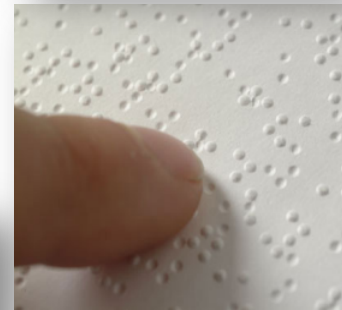

The Cerebral Cortex

Conscious
↑

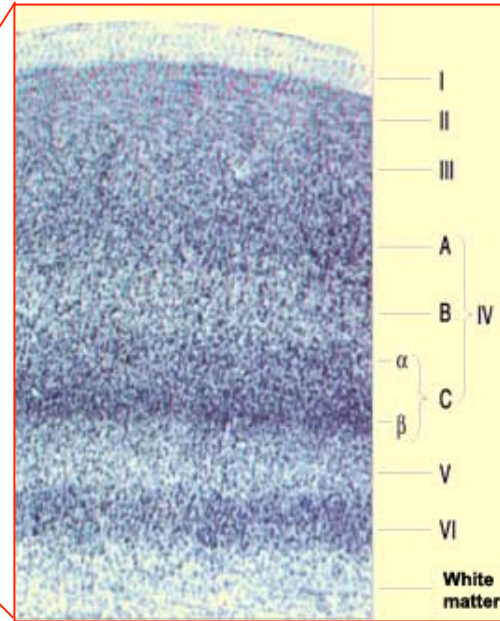
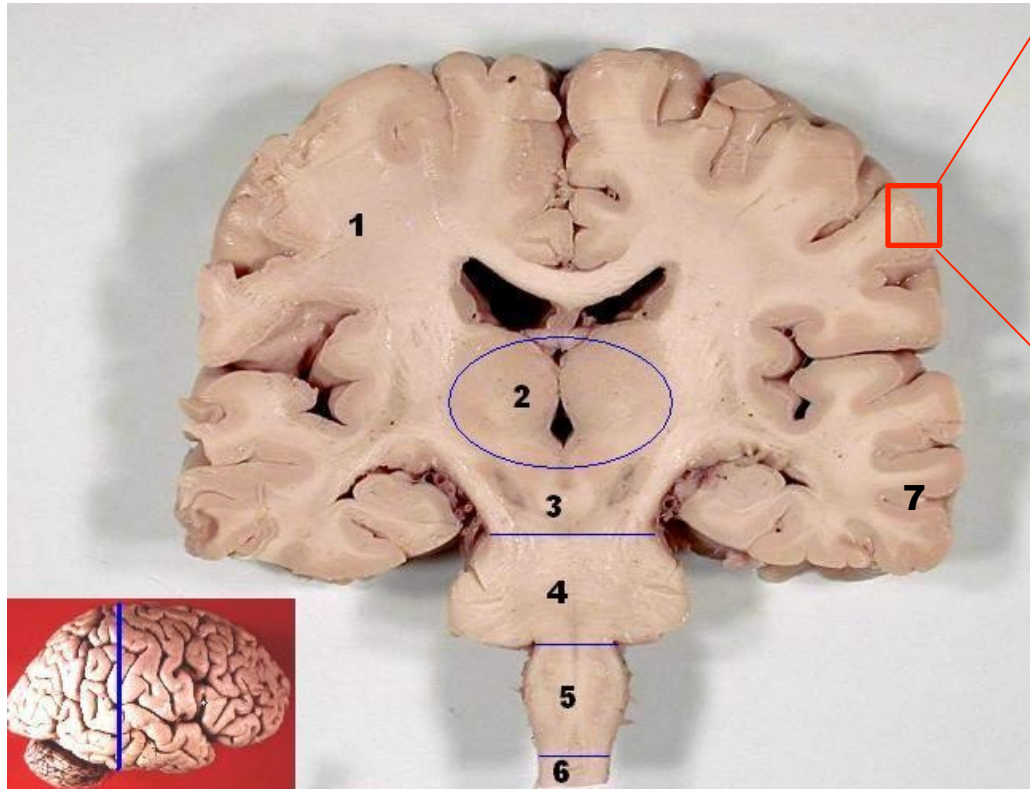

↓
Unconscious

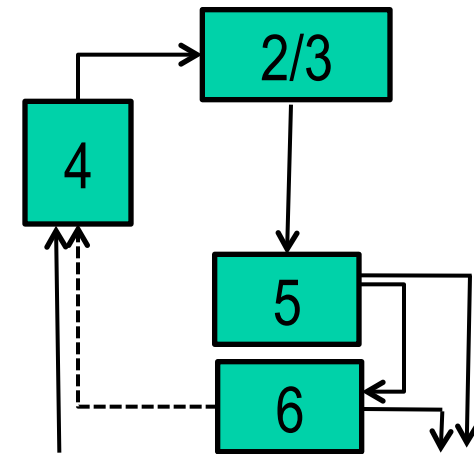

Assembly of rat's cortical circuits during development

How/when do neurons establish networks? → *Symmetry Breaking*

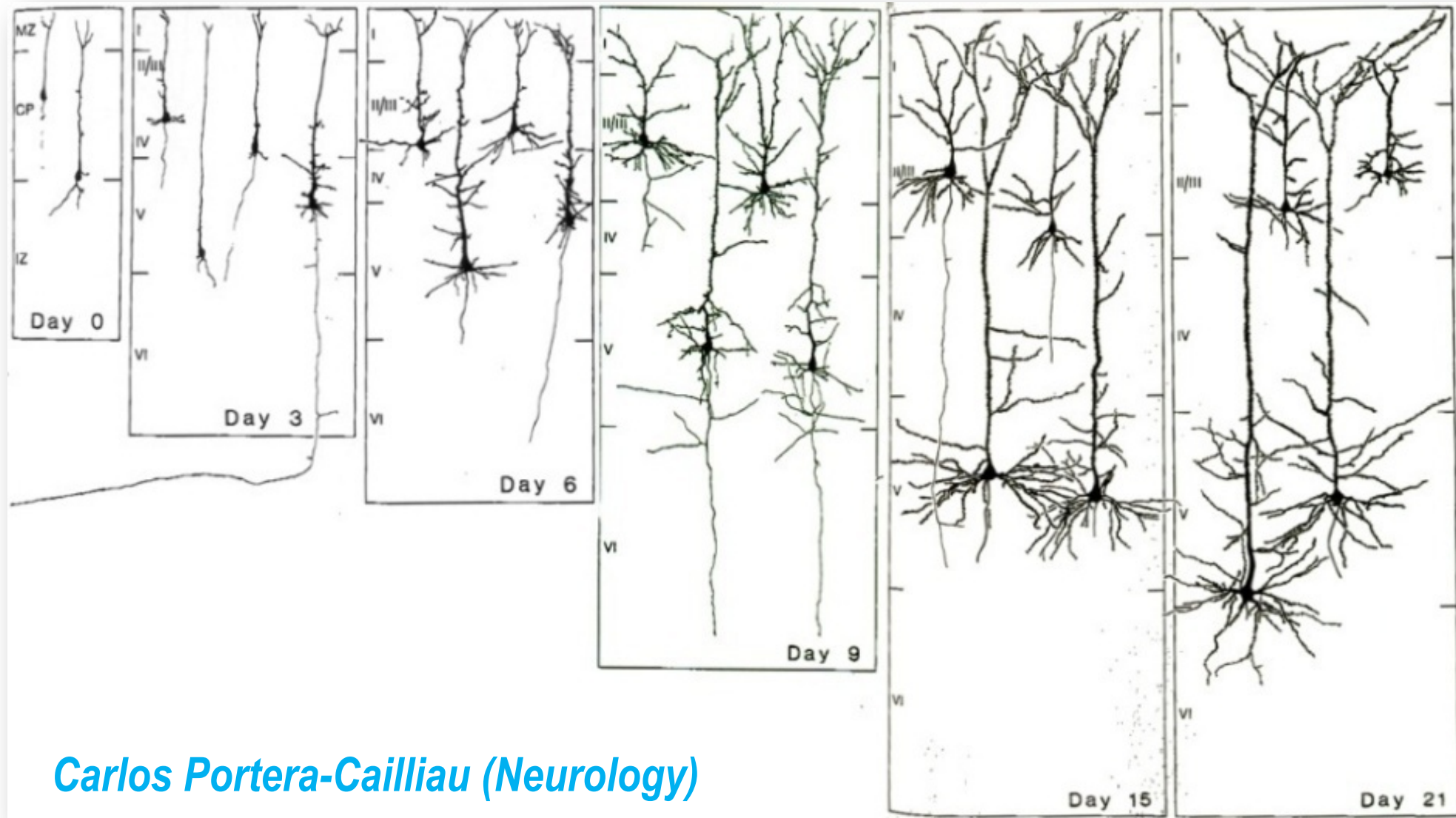

Multiphoton Microscope

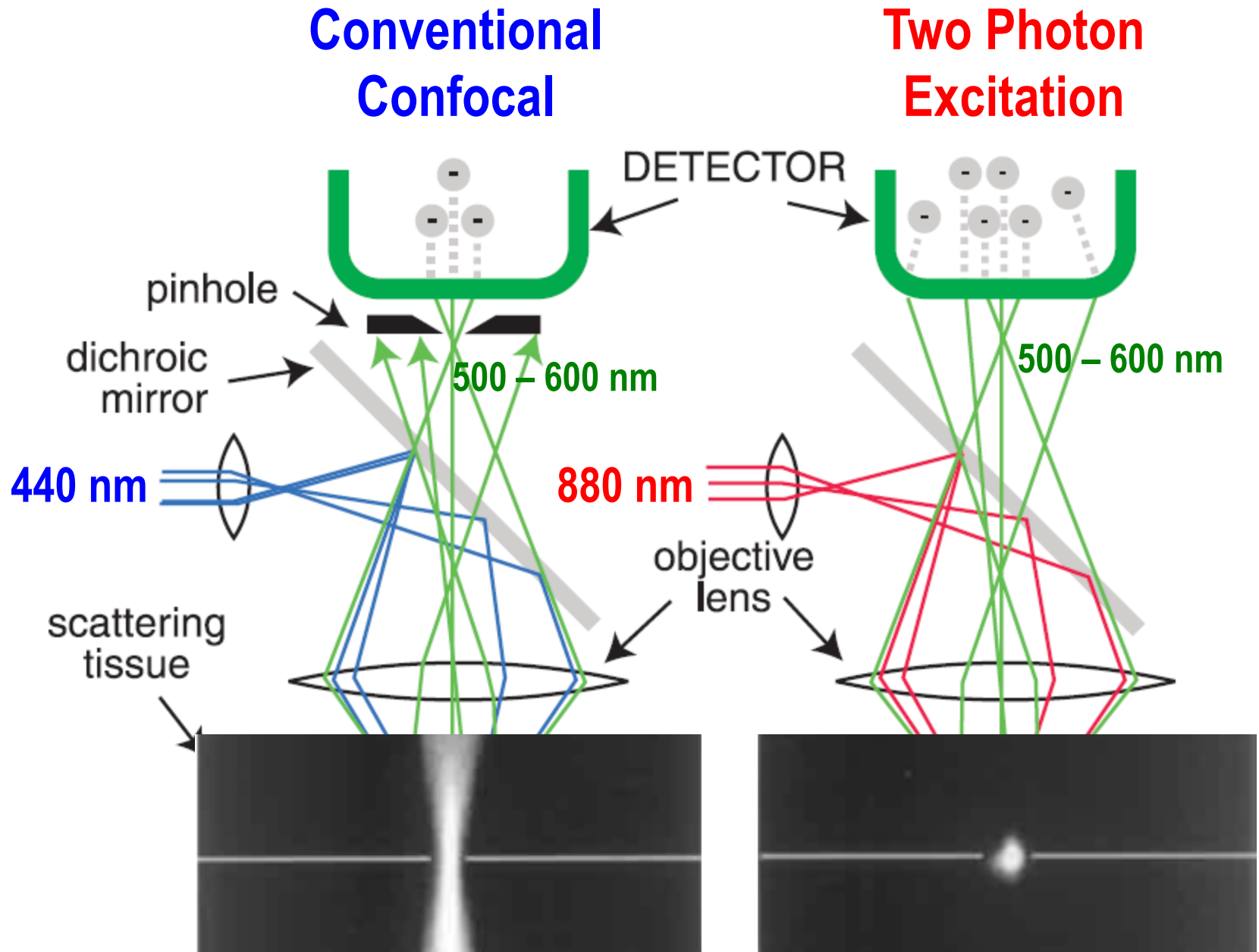

Principle of High-speed Bio Imaging

Wide Field

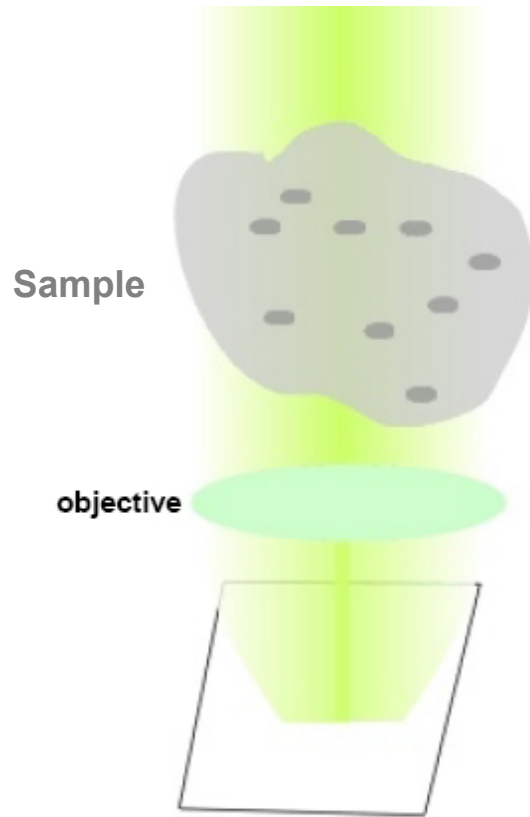

CCD + FADC (10 – 50 MHz)



CMOS [FADC (50 MHz) * 100]

Confocal

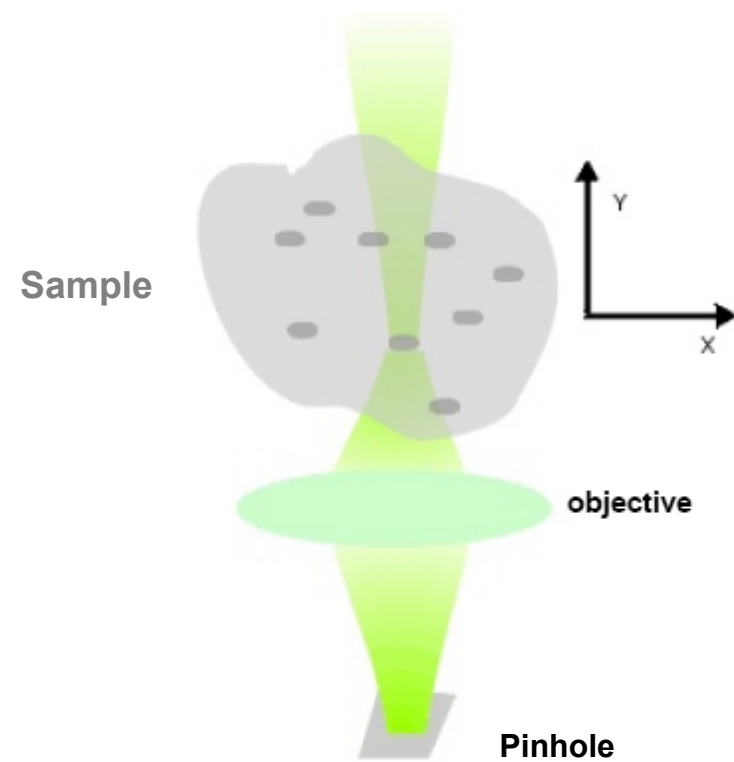

PMT + FADC (10 – 50 MHz)



[HAPD + FADC (1 GHz)] * 64

Hamamatsu Hybrid APD

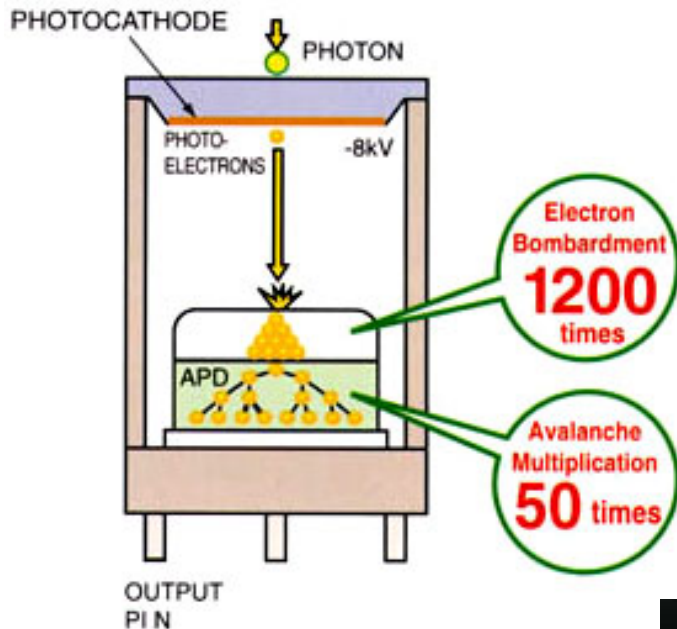

Single Channel
HAPD

64 Channel HAPD
+ Readout

Motohiro Suyama
(Hamamatsu)
Xavier Michalet
Shimon Weiss
(Chemistry)

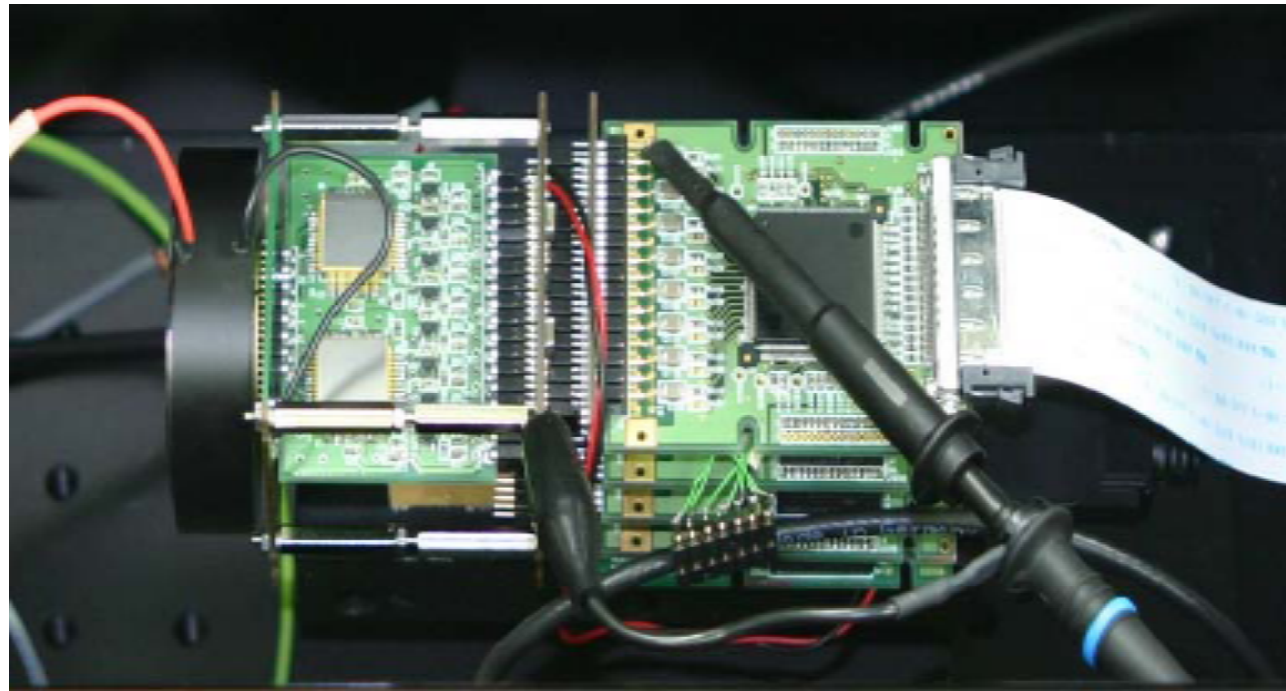

Quantum Efficiency of UBA, GaAsP and GaAs

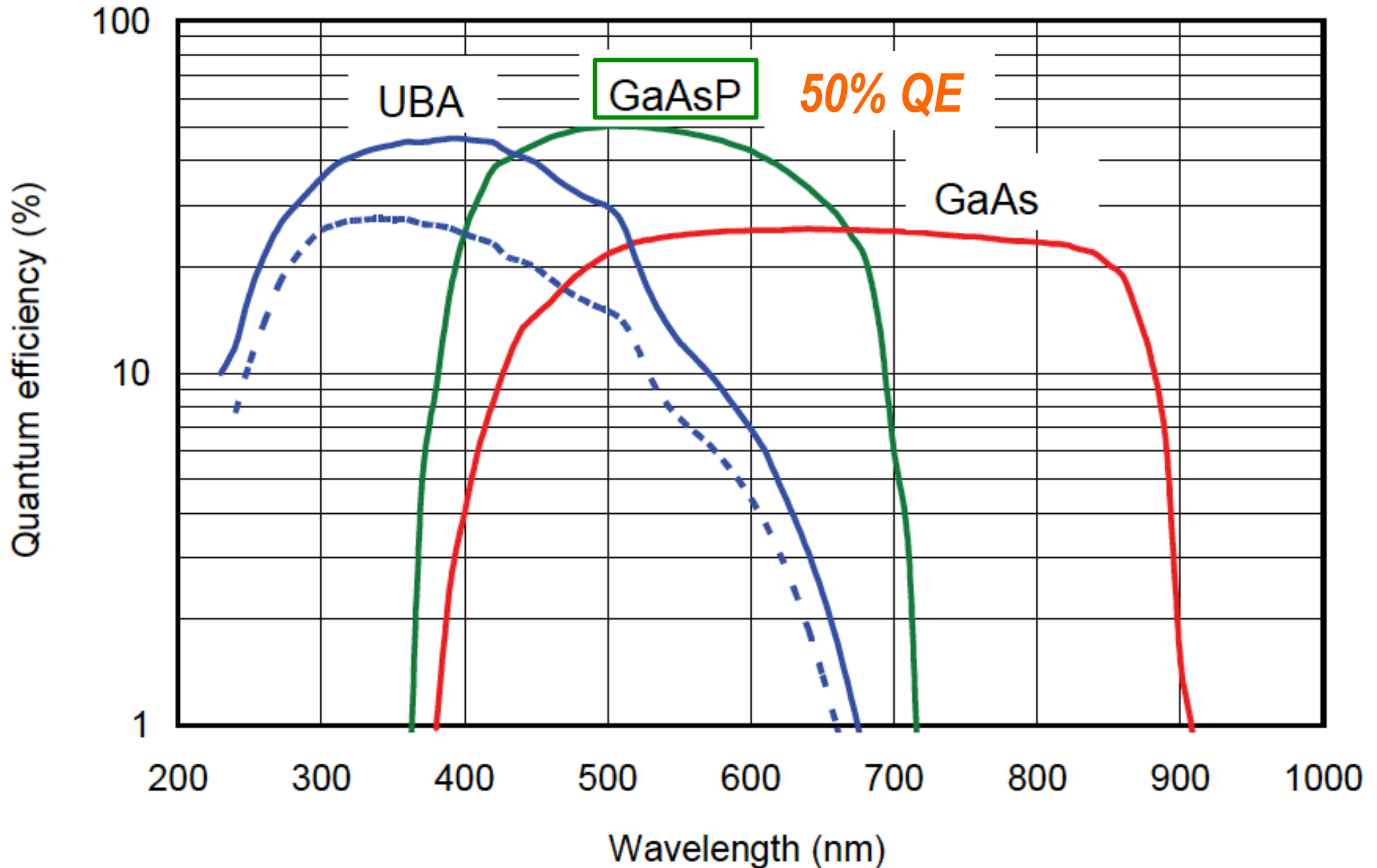

1, 2, 3 ... Photo-electron Distribution

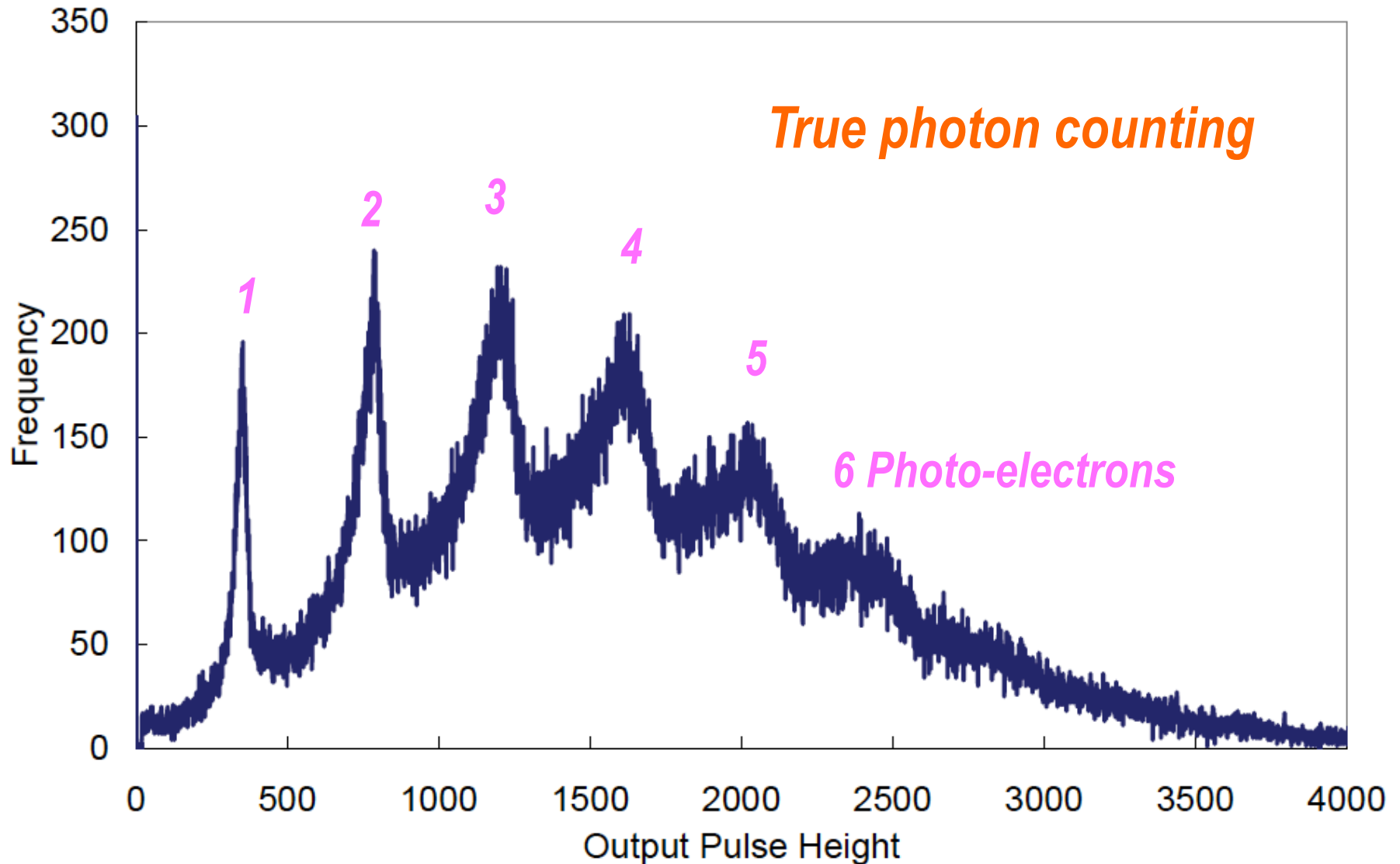

Decay Time Measurement by HAPD

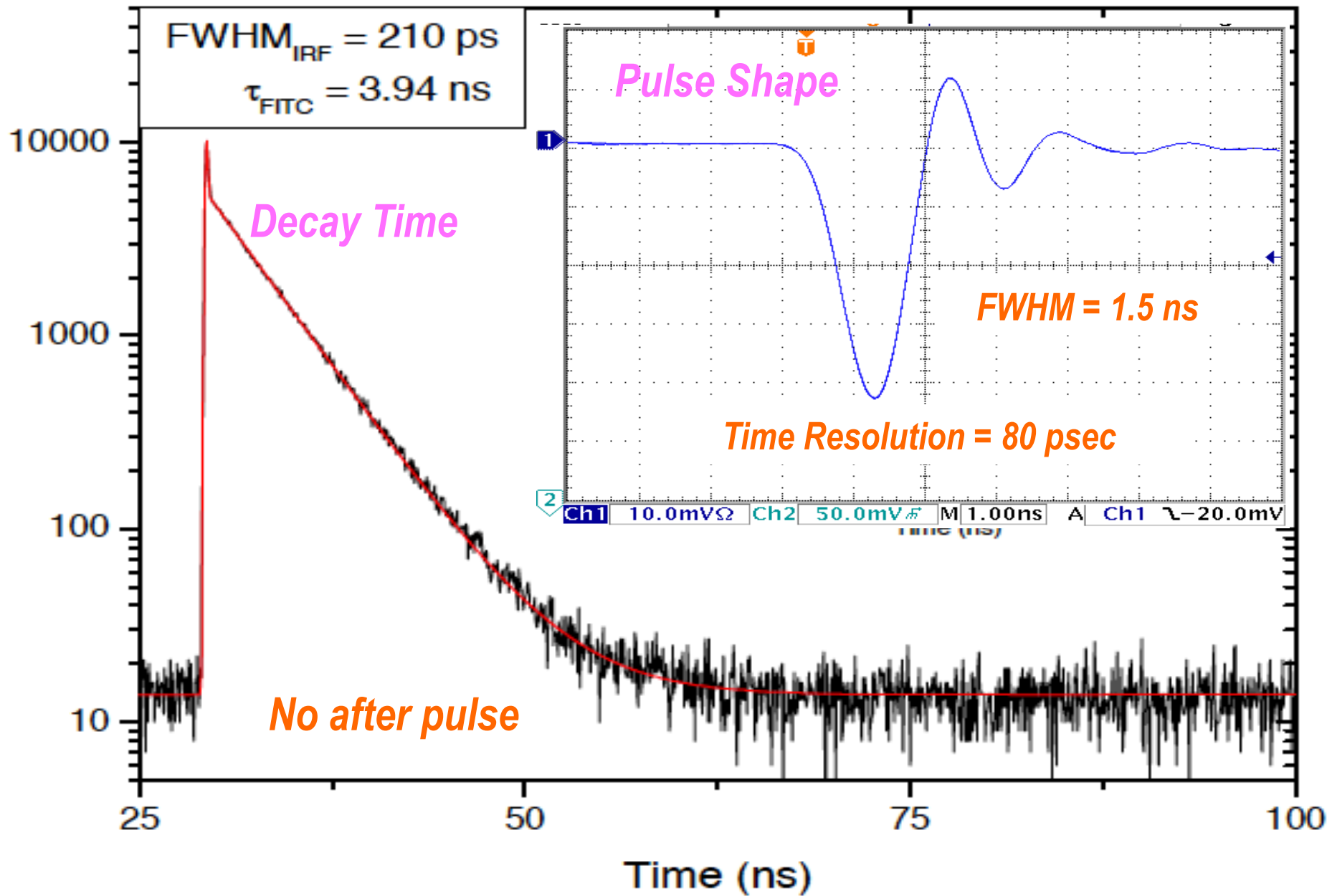

Spatio-Temporal Excitation-Emission Multiplexing (STEM) Microscope

Adrian Cheng (Physics)

Carlos Portera-Cailliau (Neurology)

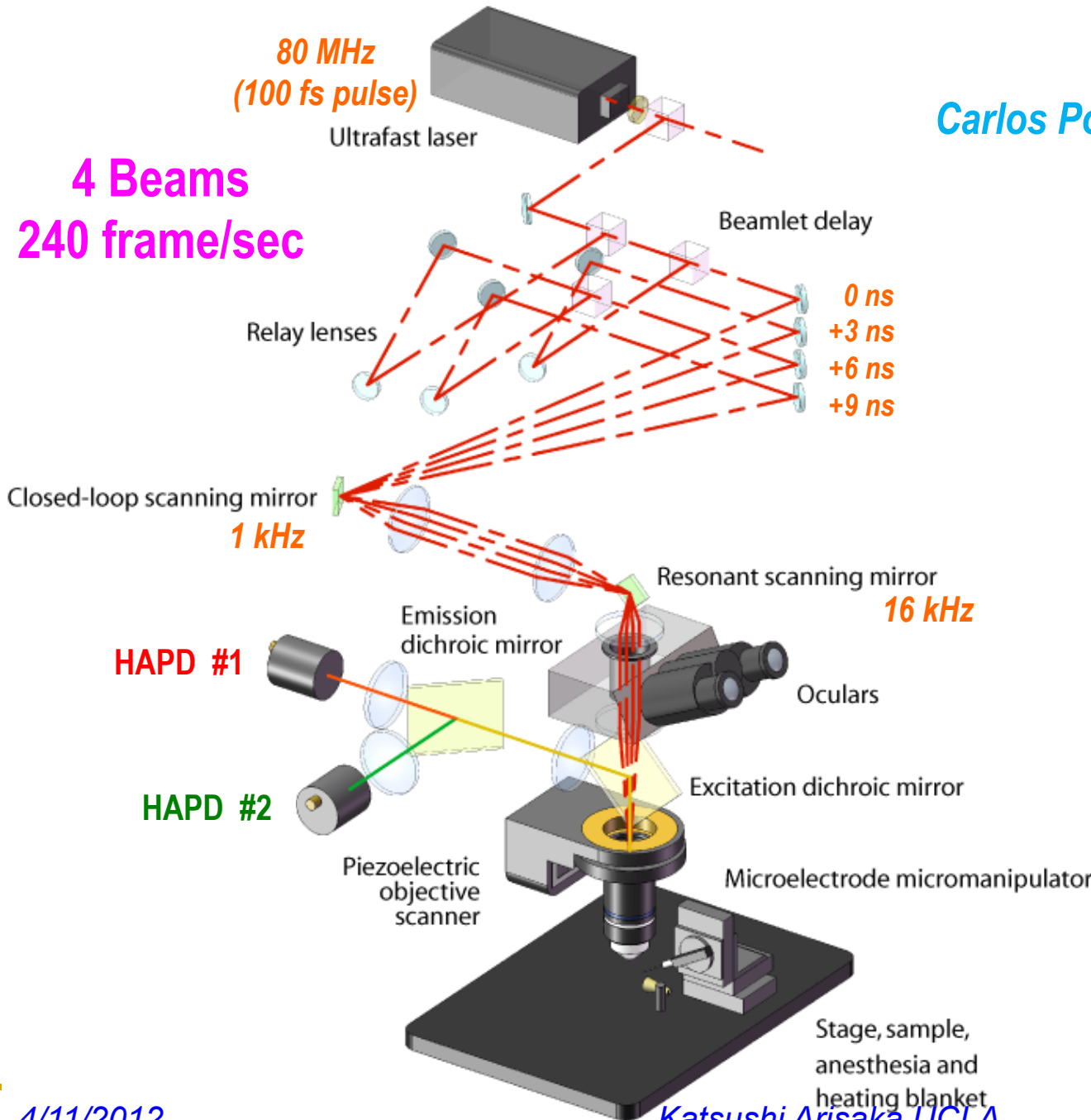

Single beam



Oscilloscope



Histogram

Spatio-temporally multiplexed MMM



Oscilloscope



Histogram

12 ns

In vivo calcium imaging of neuronal activity

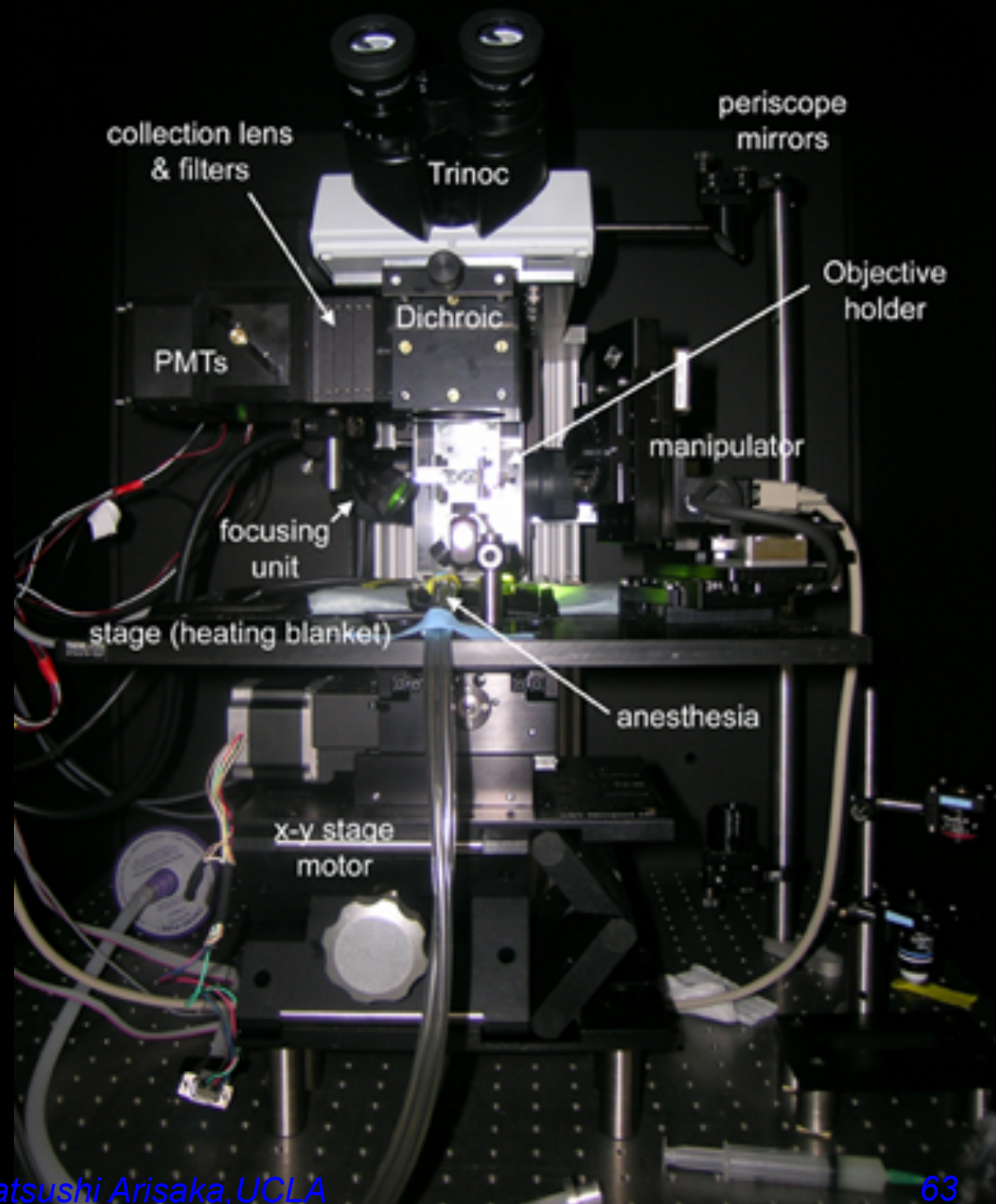
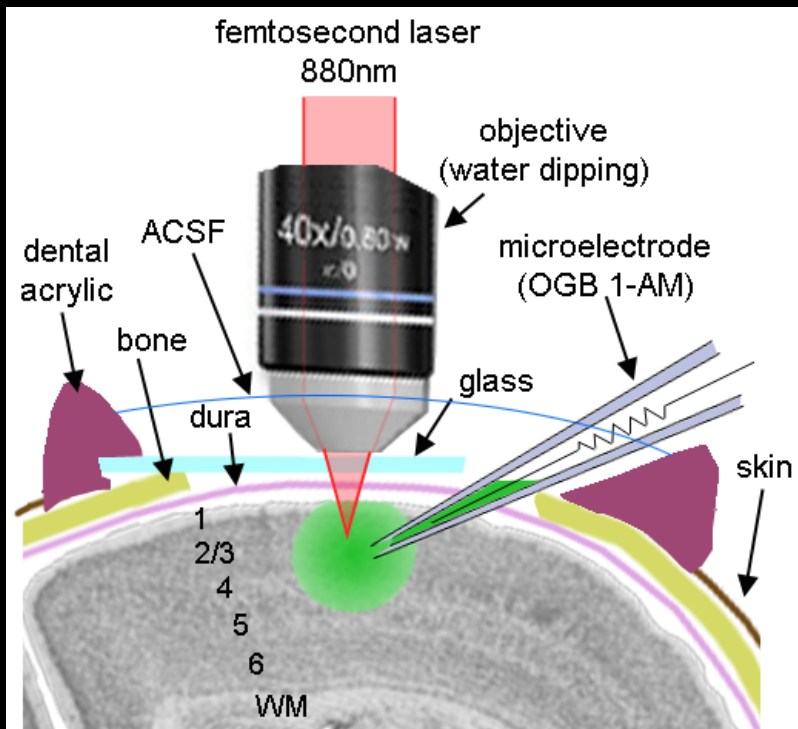

Fluo-4 AM labeled astrocytes are colabeled with sulforhodamine 101 to eliminate background (yellow)

Glass microelectrode for dye injection and electrophysiology

- cell-attached voltage follower
- whole-cell voltage/current clamp
- $10^{15} \Omega$ input impedance, $< 150 \text{ fA}$ input current bias

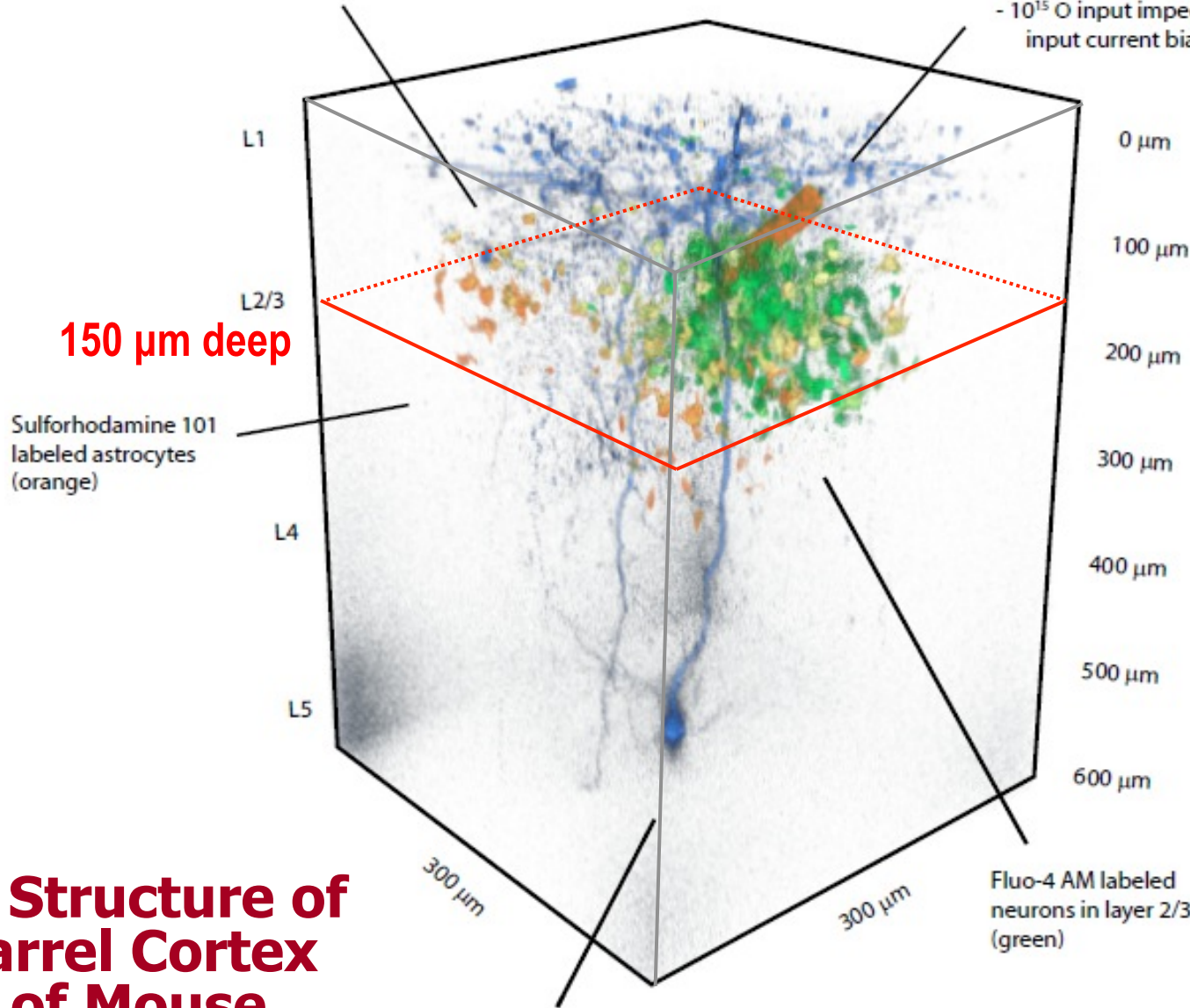

*Adrian Cheng
(Physics)*

*Tiago Goncalves,
Peyman Golshani,
Carlos Portera-Cailliau
(Neurology)*

3D Structure of Barrel Cortex of Mouse

Layer 5 pyramidal neuron soma and apical dendrite from a transgenic animal demonstrates imaging depth (blue)

Katsushi Arisaka, UCLA

In vivo calcium imaging of Barrel Cortex of Mouse

**Barrel Cortex
Layer 2/3**

150 μm deep

**240 fps
Raw Data**

**(x3 faster
than real)**

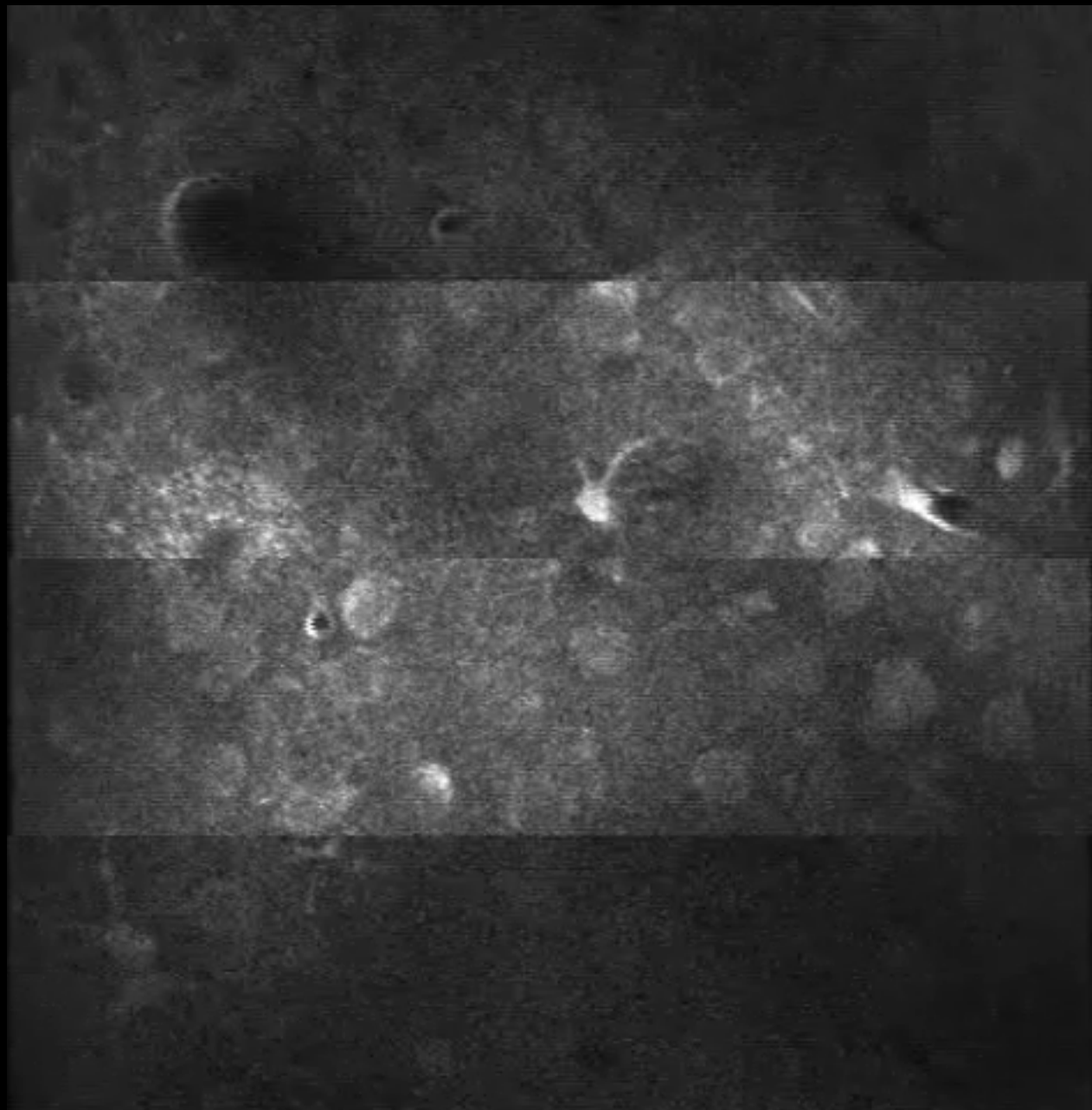

**Beam 1
(0 ns)**

**Beam 2
(+3 ns)**

**Beam 3
(+6 ns)**

**Beam 4
(+9 ns)**

In vivo calcium imaging of Barrel Cortex of Mouse

Barrel Cortex
Layer 2/3

150 μm deep

After
averaging

(x3 faster
than real)

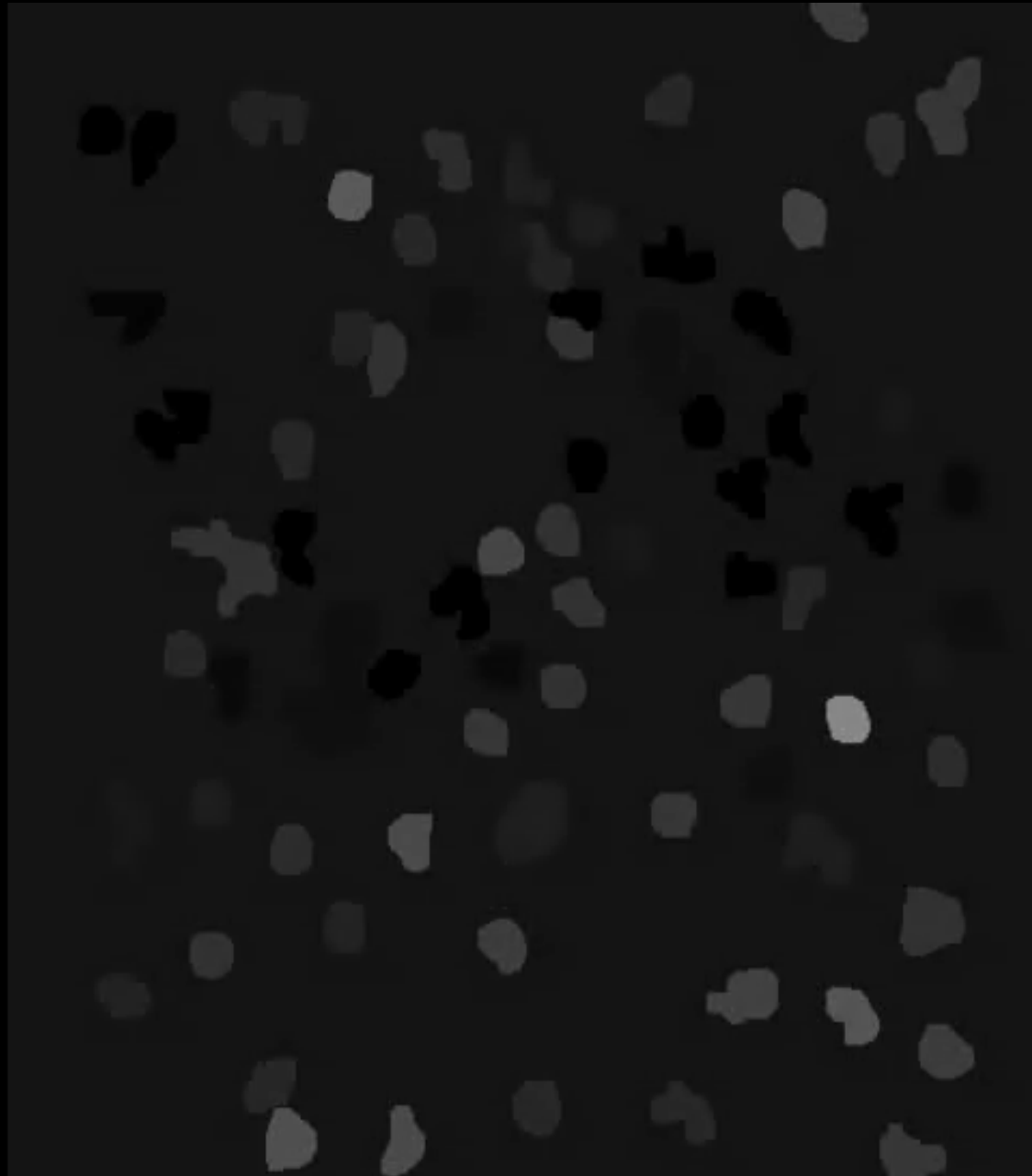

58 neurons

(~100 billions
neurons
in our brain)

In vivo calcium imaging of layer 2/3 neurons in barrel cortex with STEM

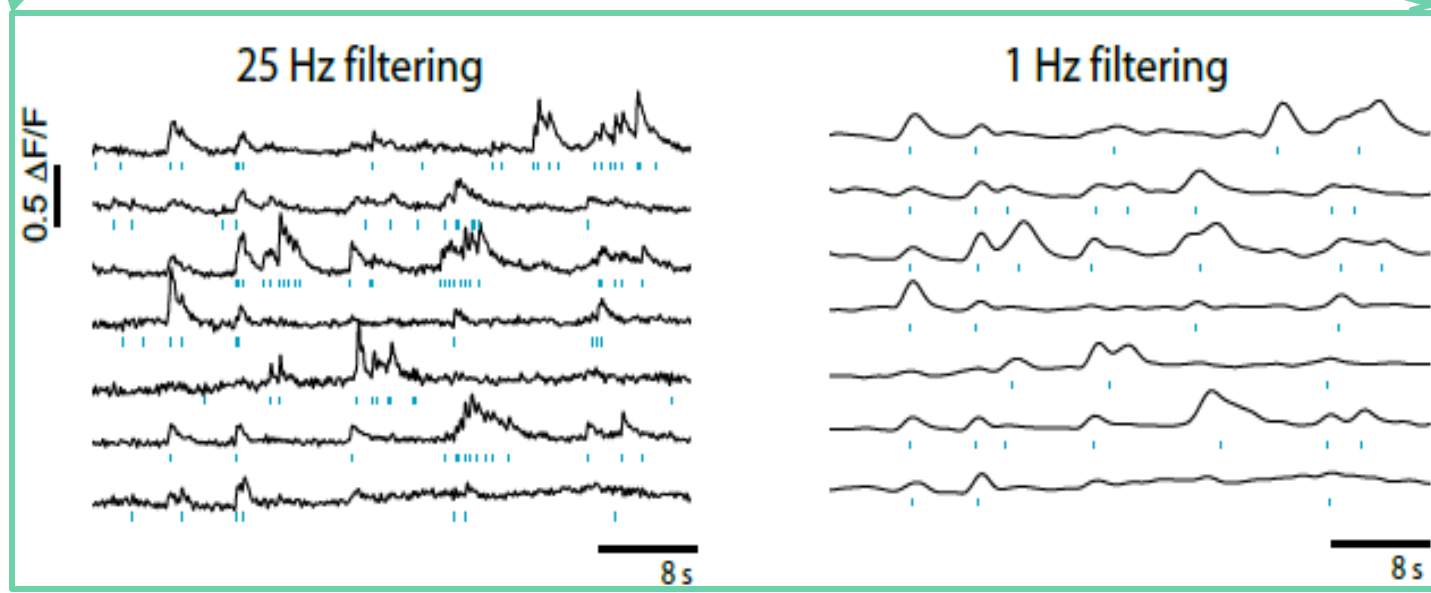
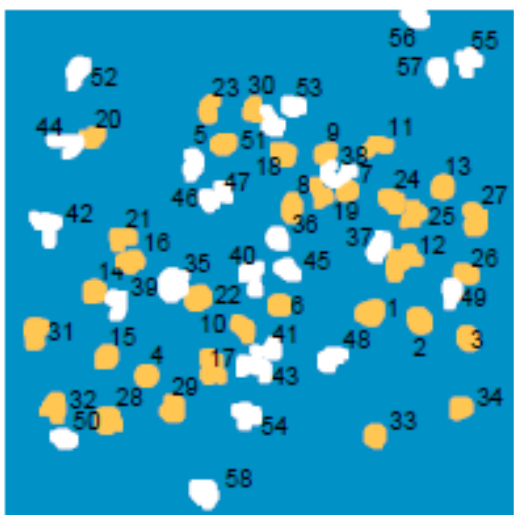
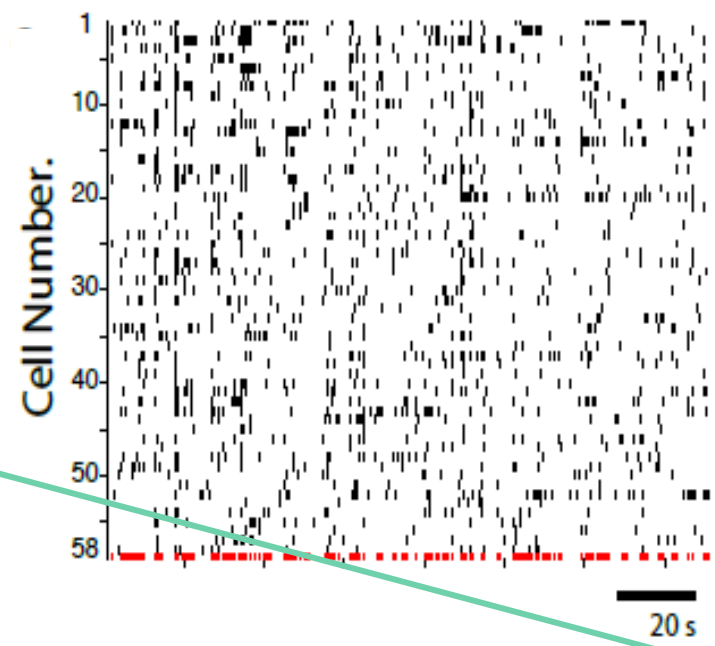
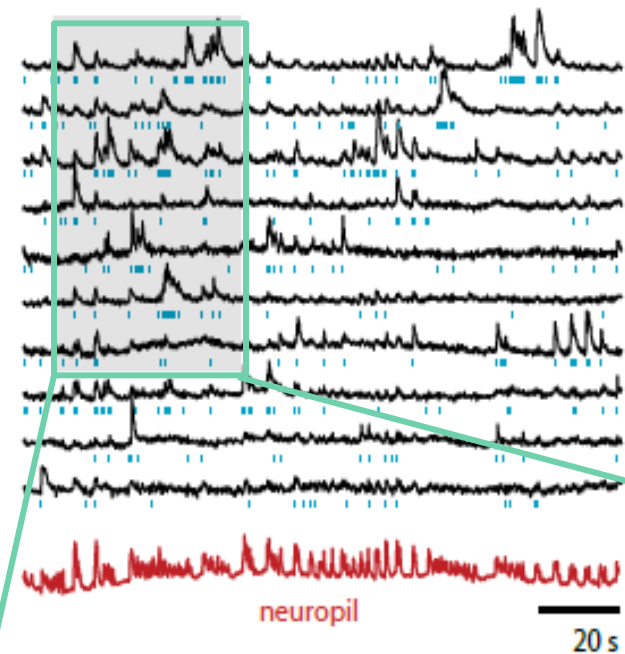
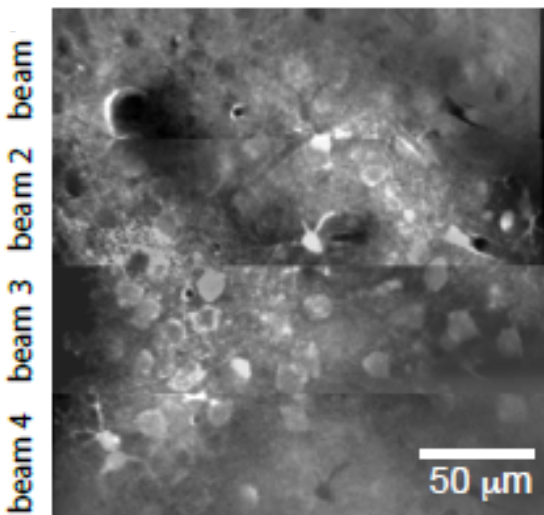

Adrian Cheng (Physics)

Fluo-4 AM labeled astrocytes are colabeled with sulforhodamine 101 to eliminate background (yellow)

Glass microelectrode for dye injection and electrophysiology

- cell-attached voltage follower
- whole-cell voltage/current clamp
- $10^{15} \Omega$ input impedance, $< 150 \text{ fA}$ input current bias

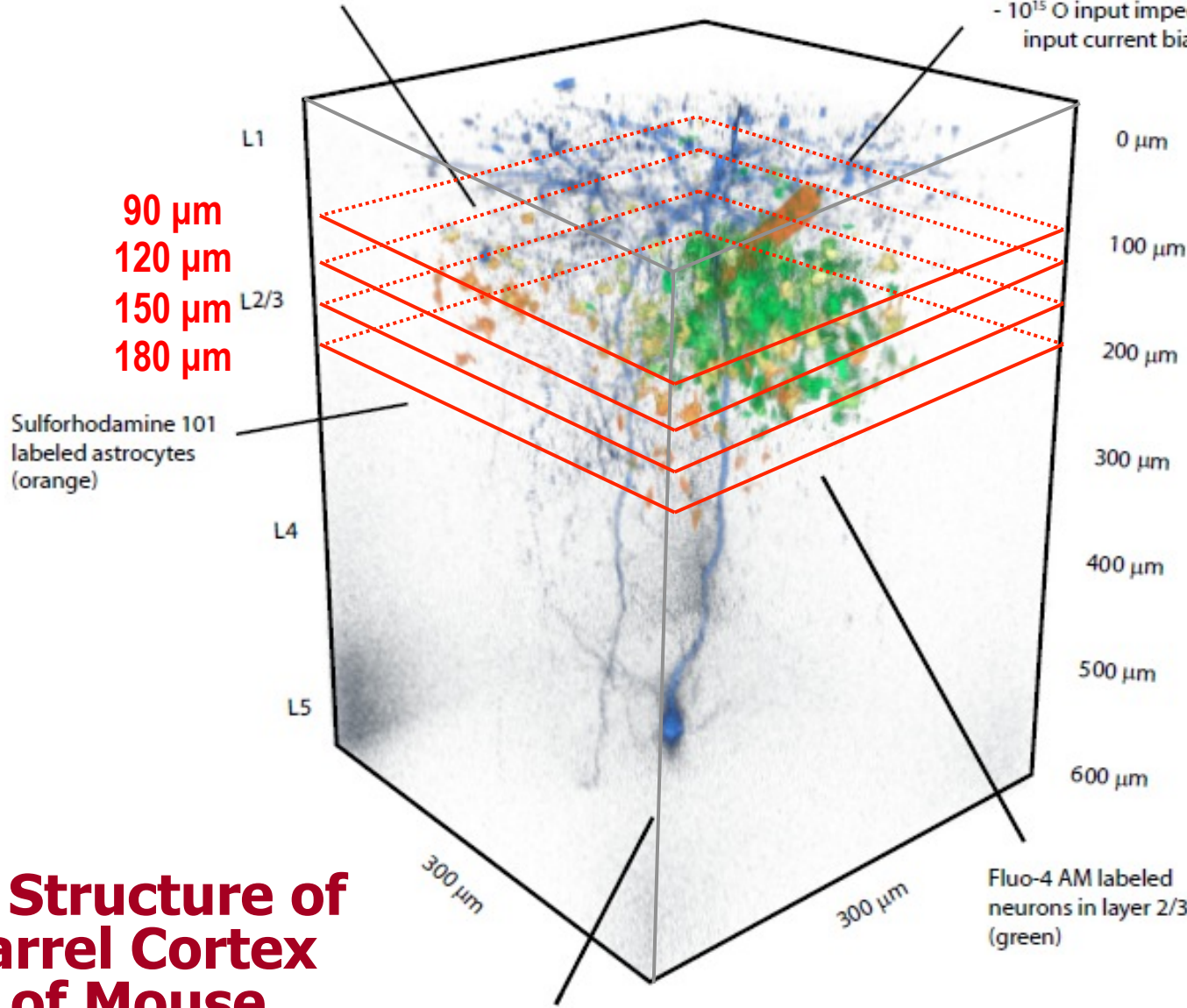

3D Structure of Barrel Cortex of Mouse

Adrian Cheng
(Physics)

Tiago Goncalves,
Peyman Golshani,
Carlos Portera-Cailliau
(Neurology)

Layer 5 pyramidal neuron soma and apical dendrite from a transgenic animal demonstrates imaging depth (blue)

Simultaneous in vivo calcium imaging in 4 axial planes

Barrel
Cortex
Layer 2/3

60 fps

(x3 faster
than real)

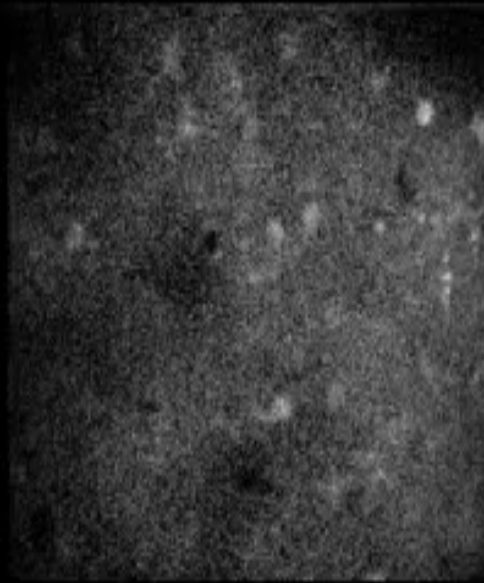

Beam 1

90 μm

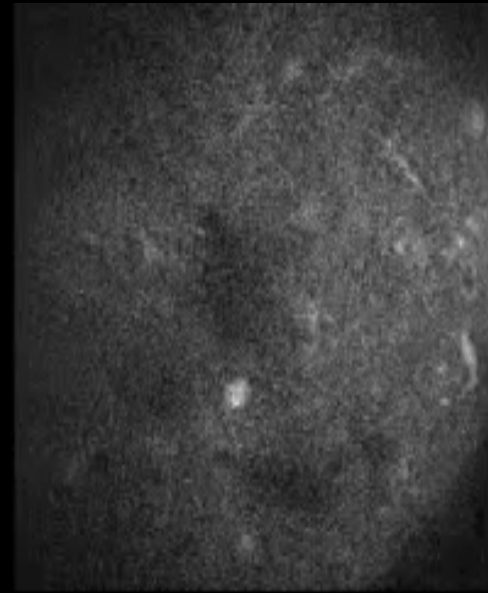

Beam 2 120 μm

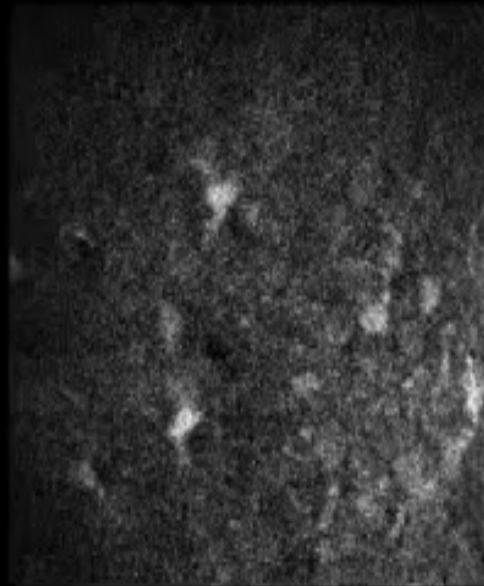

Beam 3

150 μm

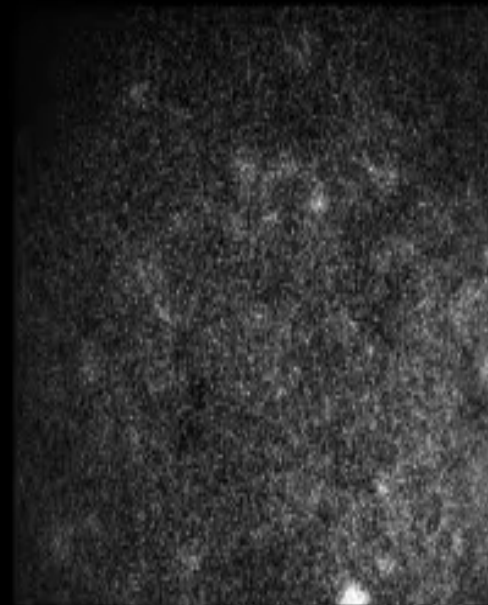

Beam 4 180 μm

Simultaneous in vivo calcium imaging of neuronal activity in 4 axial planes with STEM

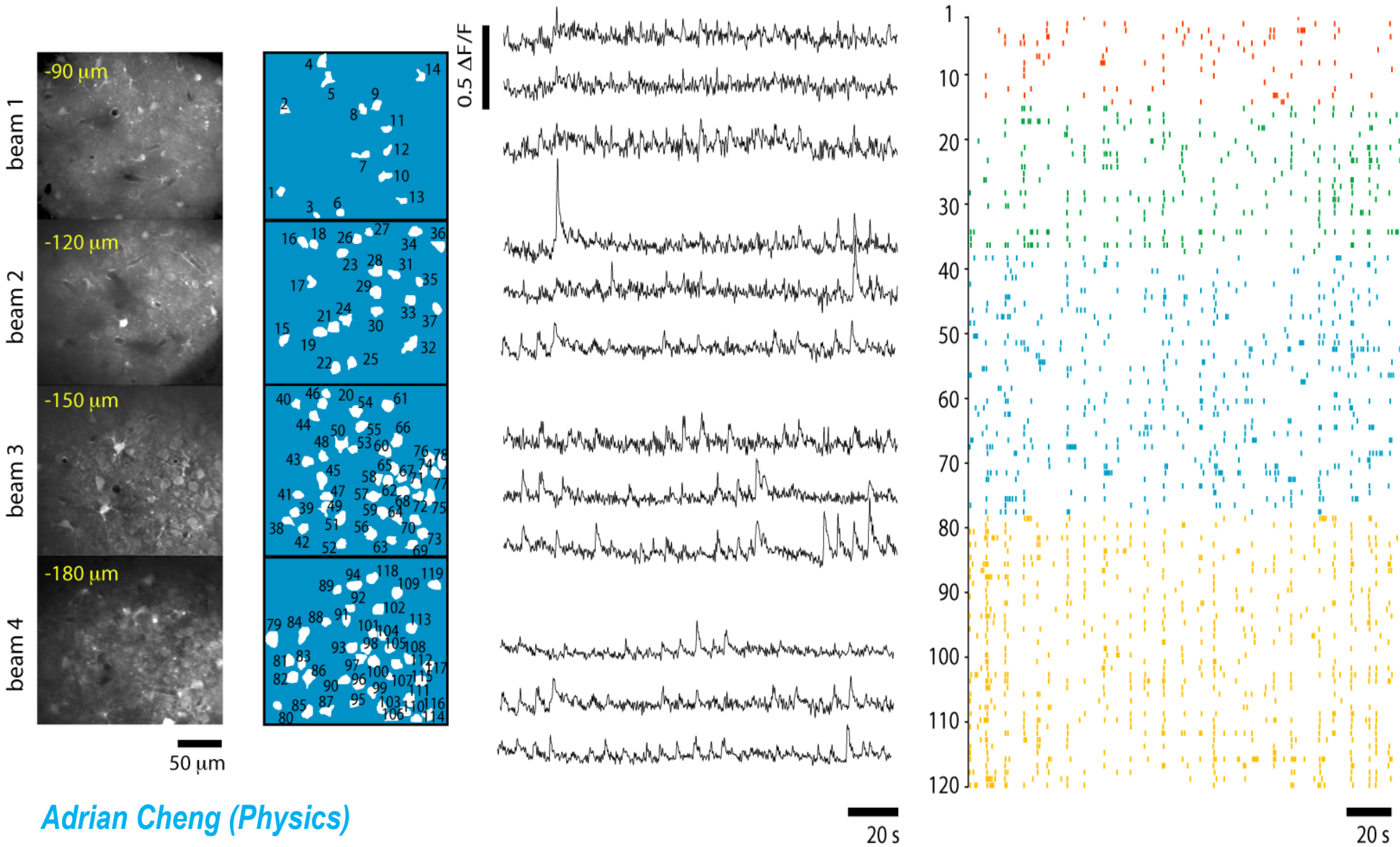

Adrian Cheng (Physics)

UCLA Newsroom on January 11, 2011

January 11, 2011

[UCLA Home](#) [Campus Directory](#)

[Media Contacts](#) [News Releases](#) [About UCLA](#)

UCLA Newsroom

Search UCLA Newsroom

Go

Home

All Stories

- › All Stories
- › Featured News
- › **News Releases**
- › Advisories
- › Images
- › Video

Research

Health Sciences

Arts & Humanities

Student Affairs

Academics & Faculty

UCLA News Week

Campus News

Images

Video

Blog

For News Media

News releases

[UCLA Newsroom](#) > [All Stories](#) > [News Releases](#)

New UCLA-designed microscope records firing of thousands of individual neurons in 3-D

Imaging system could help reveal 'miscommunications' in autism, schizophrenia

By **Mark Wheeler** | January 11, 2011



Some disorders of the brain are obvious — the massive death of brain cells after a stroke, the explosion in the growth of cells that marks a tumor. Other disorders, such as autism, schizophrenia and mental retardation show no physical signs of damage and are believed to be caused by problems in how brain cells communicate with one another.

To understand the root of the problem of these latter diseases, visualizing brain activity is key. But even the best imaging devices available — fMRIs and PET scans — can only give a "coarse" picture of brain activity.

UCLA neuroscientists have now collaborated with physicists to develop a non-invasive, ultra-high-speed microscope that can record in real time the firing of thousands of individual neurons in the brain as they communicate, or miscommunicate, with each other.

"In our view, this is the world's fastest two-photon excitation microscope for three-dimensional imaging *in vivo*," said UCLA physics professor Katsushi Arisaka, who designed the new optical imaging system with UCLA assistant professor of neurology and neurobiology Dr. Carlos Portera-Cailliau and colleagues.

Their research appears in the Jan. 9 edition of the journal *Nature Methods*.

Because neuropsychiatric diseases like autism and mental retardation often display no physical brain damage, it's thought they are caused by conductivity problems — neurons not firing properly. Normal cells have patterns of electrical activity, said Portera-Cailliau, but abnormal cell activity as a whole doesn't generate relevant information for the brain circuitry.



RSS



Alerts



Share/Print



Facebook



Twitter



Youtube

Media Contacts

Mark Wheeler,
310-794-2265
mwheeler@mednet.ucla.edu

Related Images

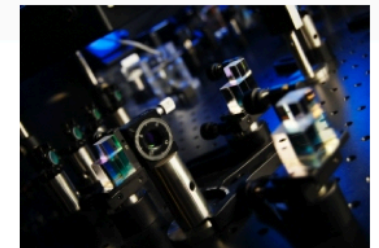

STEM microscope designed at UCLA



[View All Images](#)

Block Diagram of Multi-beam Confocal Microscope

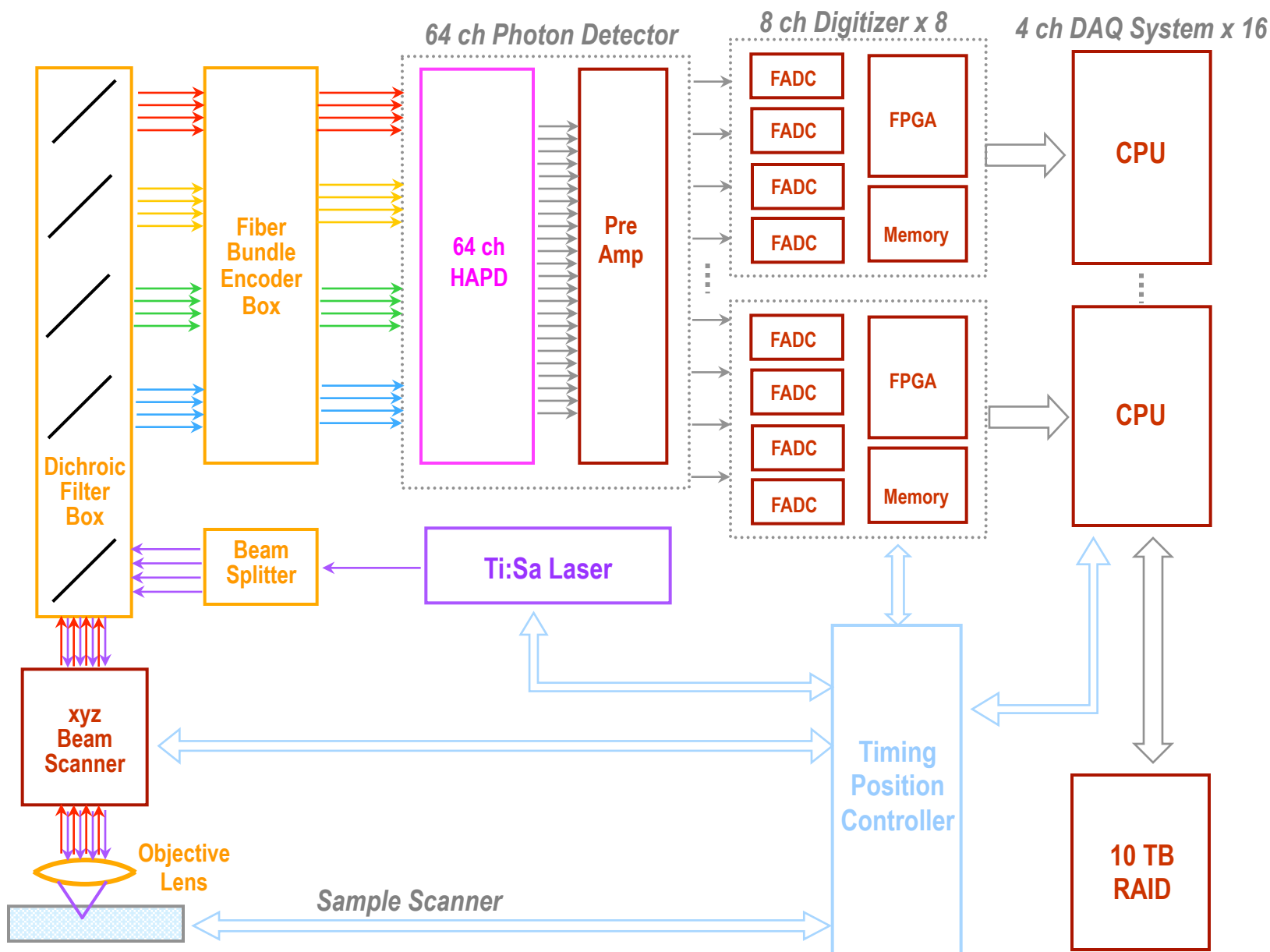

Future Directions - Virtual Reality -

How can we recognize and memorize the space?

Mayank Mehta (Physics, Neurology)



Tetrodes

Activity of (excitatory) pyramidal neurons in CA depends on rat's position: place cells

Mayank Mehta (Physics, Neurology)

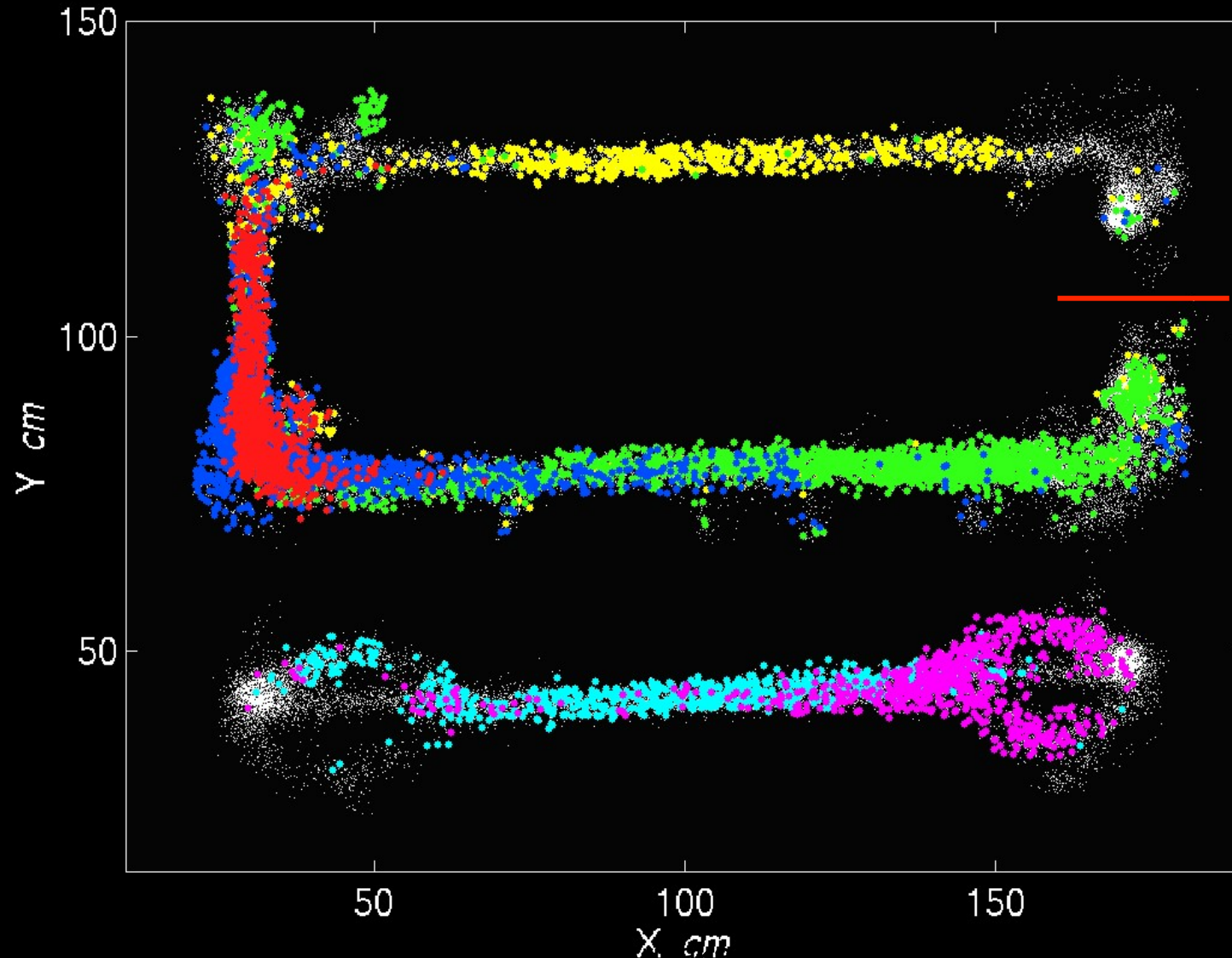

Hippocampus has a cognitive map of space

Learning and Memory by Hippocampus

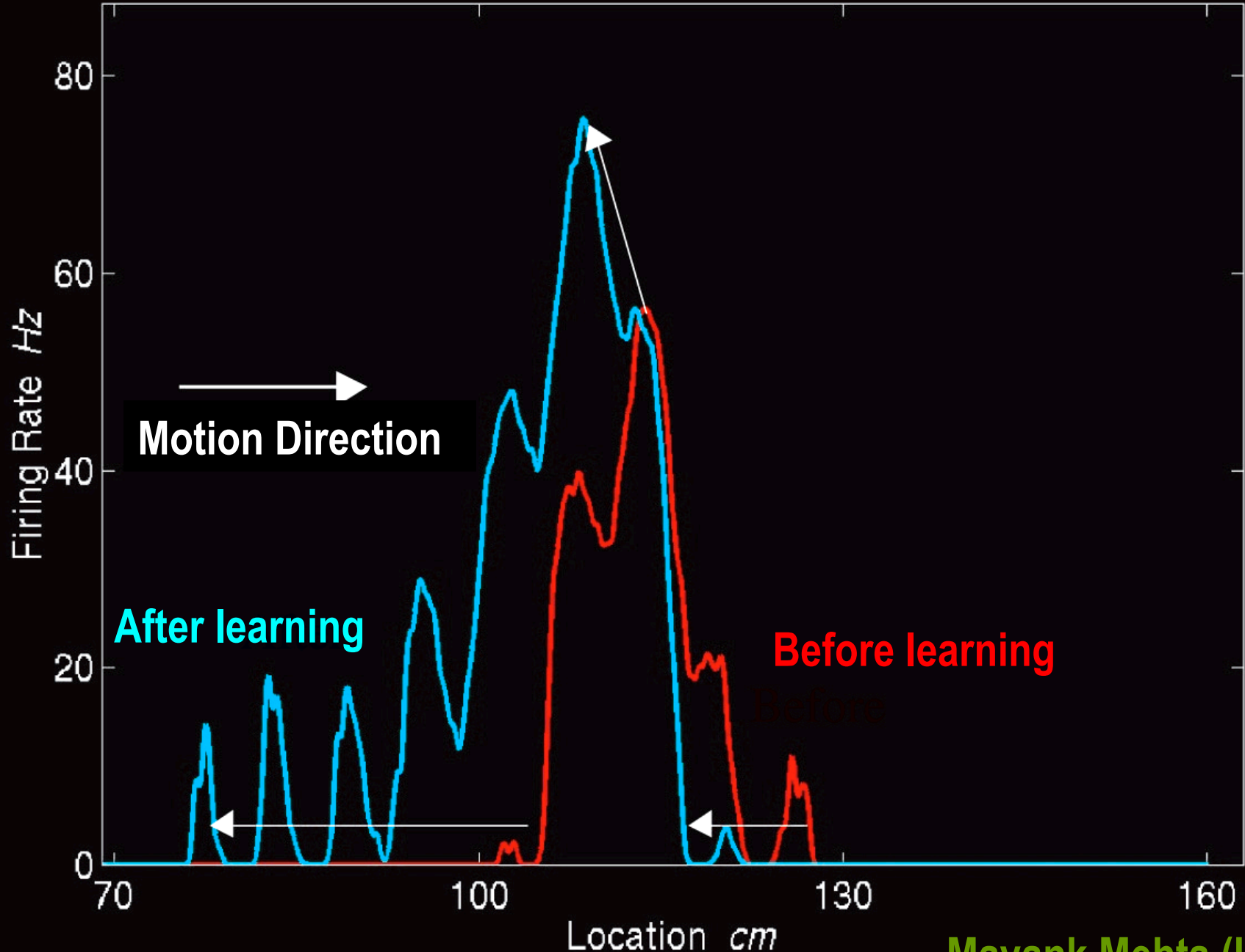

Origin of the Brain

- **Brains were evolved for animals to predict necessary motions for survival.**
 - **Find preys**
 - **Escape away from predators**
 - **Find mates for sex**
- **A brain “consciously” makes the best decision at a given time.**
- **Complex activities of brains are the results of evolution of life.**

Virtual Reality Experiment on Awake Rats

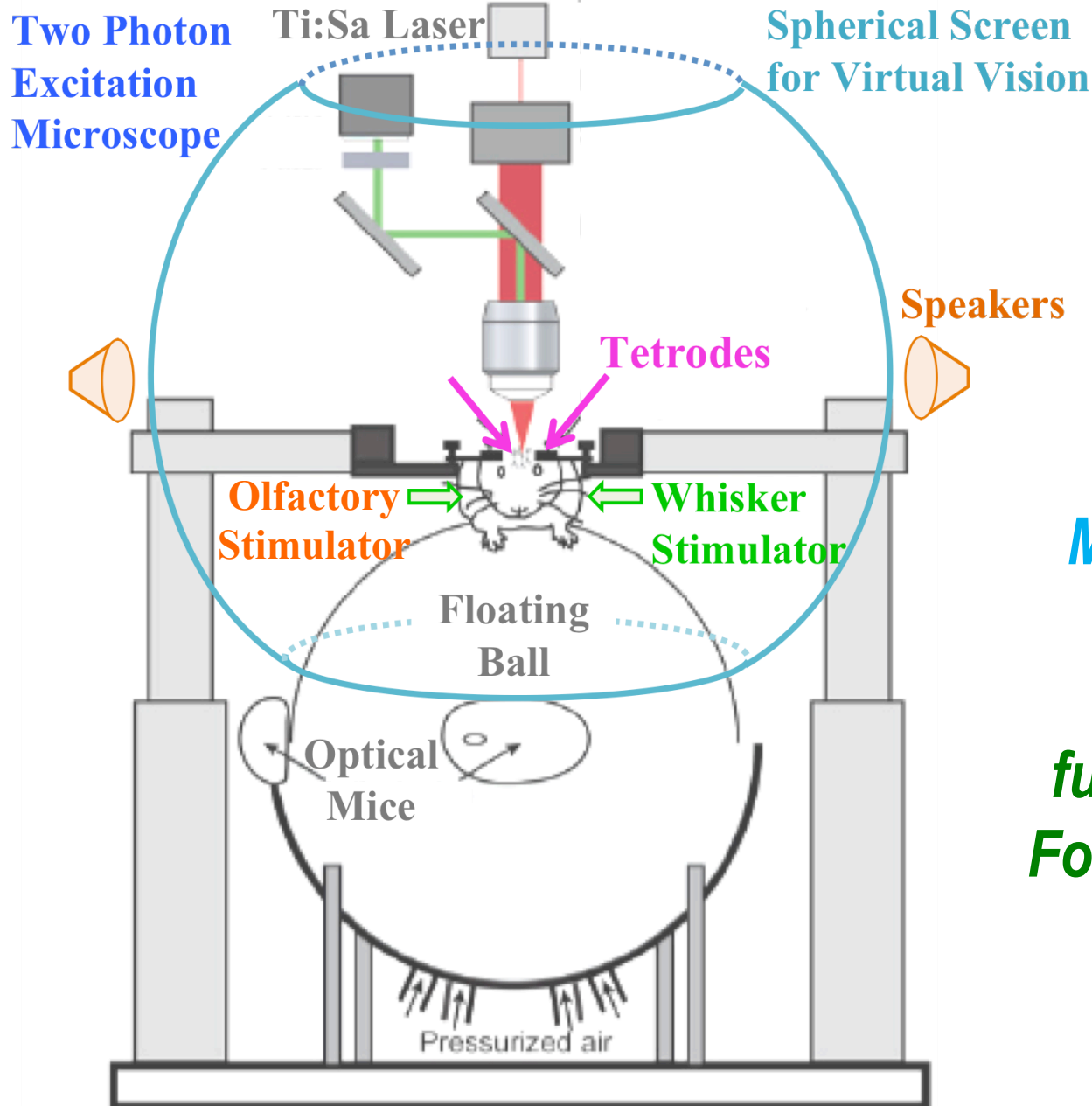

*Mayank Mehta
(Physics)*

*funded by Keck
Foundation (\$1M)*

A rat running in a Virtual Reality

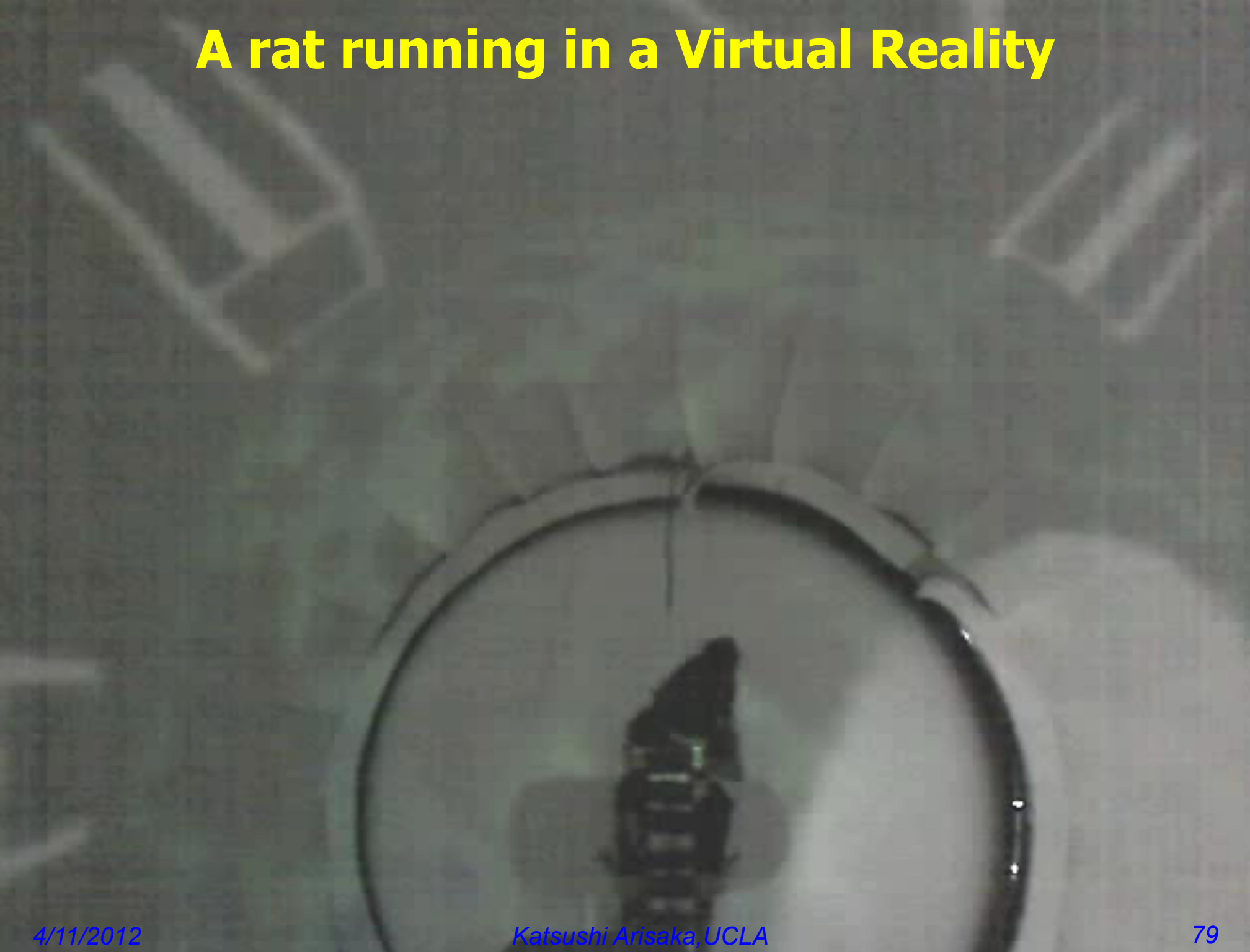

Optogenetic Excitation of Neurons

Karl Deisseroth (Stanford)

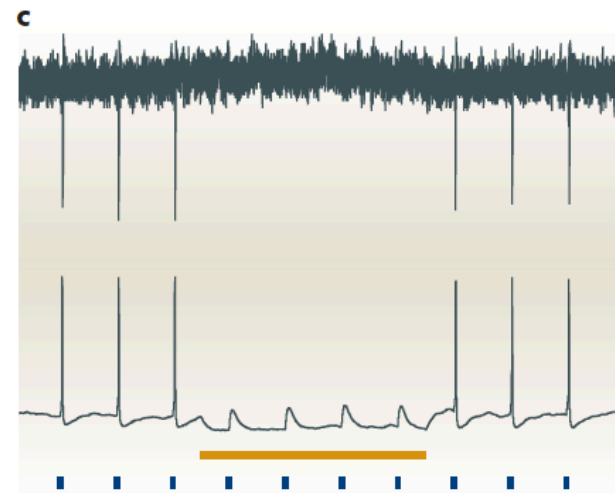
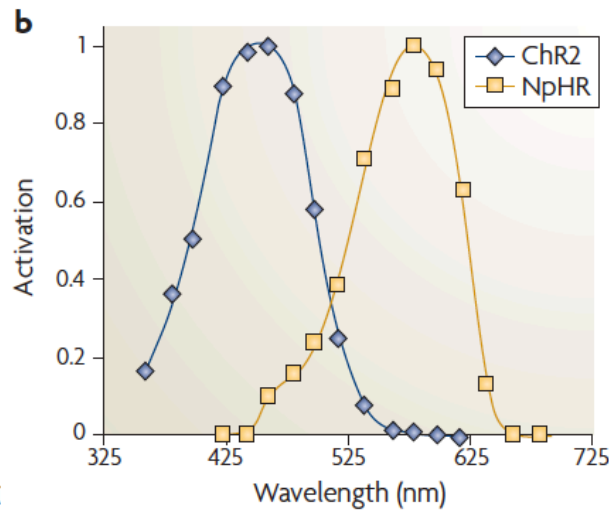
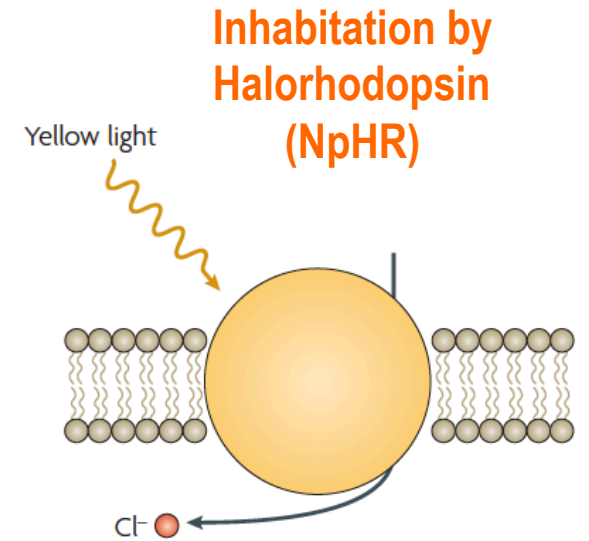
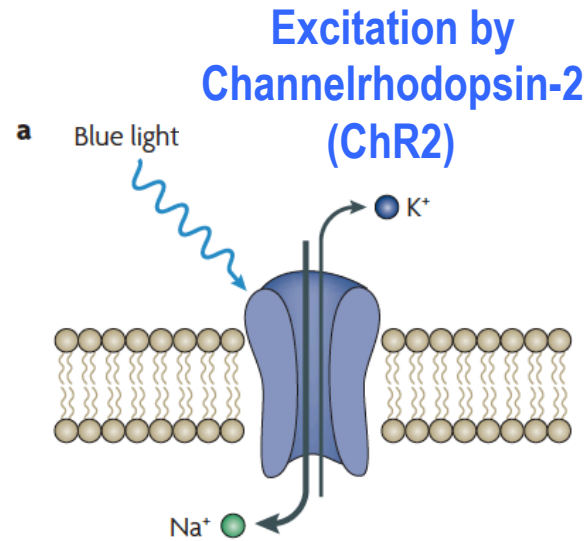
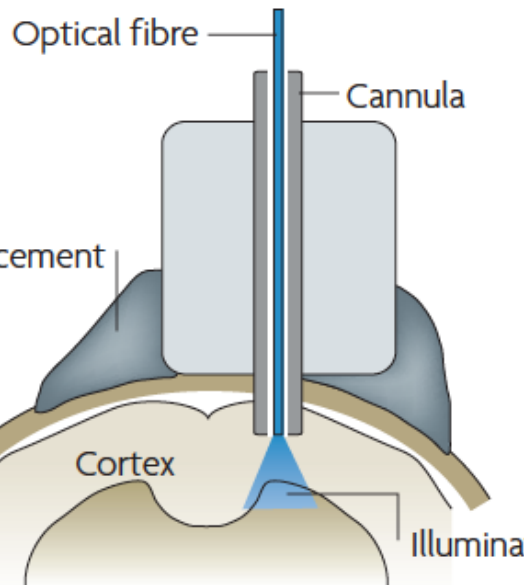

Outer world vs. Inner world

- Outer world : Five senses → Manipulate by Virtual Reality
 - Vision
 - Sound
 - Touch
 - Smell
 - Taste
- Inner world → Manipulate by Photo Excitation of single neurons
 - Neural network in brain
- Establish direct link between Inner world & Outer world
 - Control outer world – Virtual reality
 - Control inner world – Neural reality

The Origin of Consciousness

- Our brains are making enormous parallel processing “unconsciously” all the time.
 - Image processing
 - Language
 - Recognition of space-time
- “Consciousness” is merely the outcome of the decision making processes which have been performed unconsciously.
 - Language and logics are just left-over from the past.
 - We realize what we said only after we spoke.

Summary

Seven Phases of Cosmic Evolution

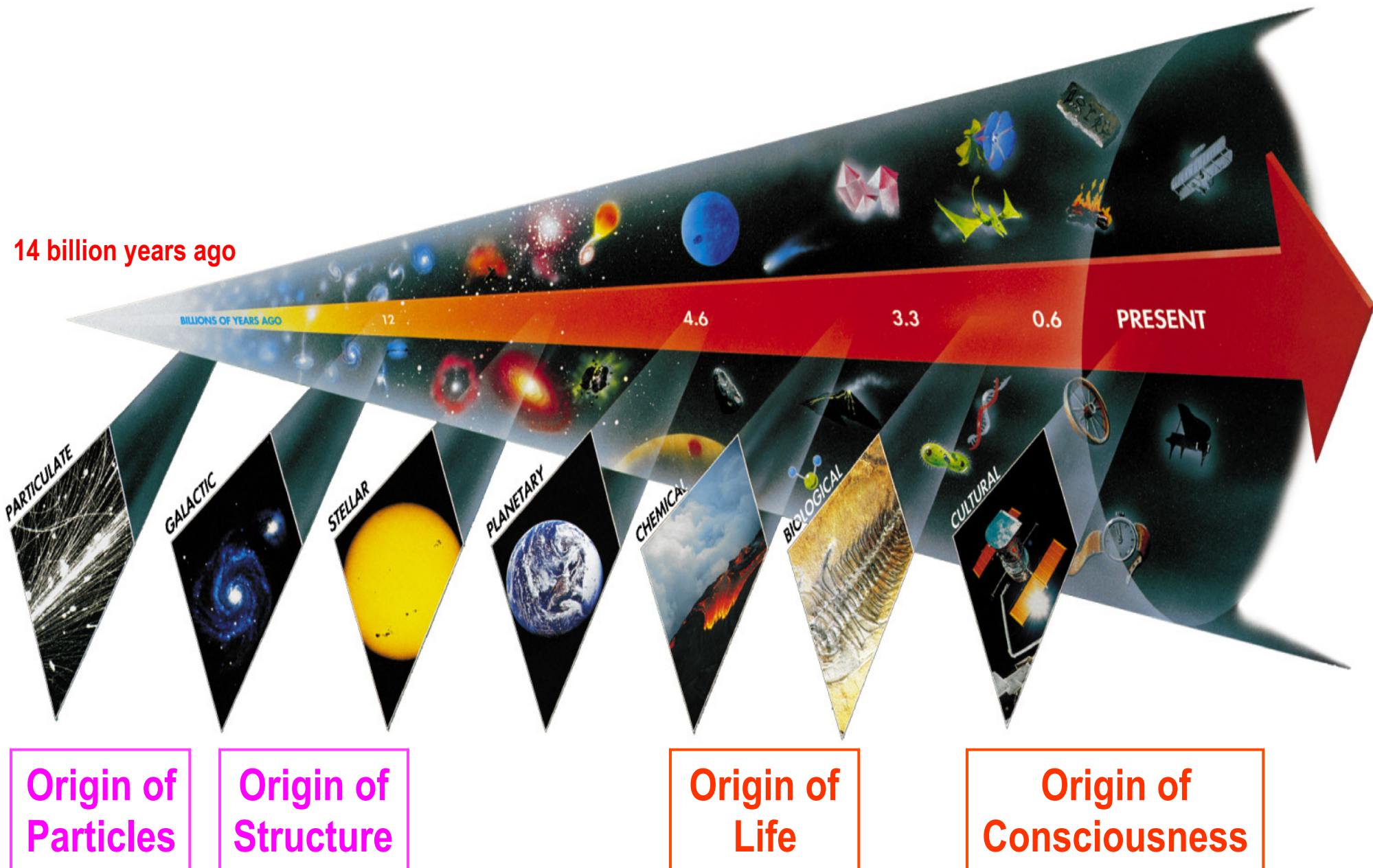

Four Major Science

Origin of Particles
Particle Physics

Origin of Universe
Cosmology

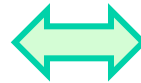

Origin of Life
Molecular Biology

Origin of Consciousness
Neurophysics

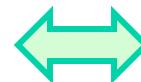

Future of Ultra High-speed Bio Imaging

➤ Origin of Life:

- Networks of molecules in/on a cell
- Competition against Brownian : 10 – 100 nm / 1 msec

➤ Origin of Consciousness:

- Neural networks
- Action potentials: 1 msec



➤ > 1,000 frame/sec with nano second time stamp.

- Gated Image Intensified CMOS
- Super-PIAS (GHz Photon-counting Imager)
- 6D Imaging by Streak-CMOS Camera

Concluding Remarks

- **“Life” is a complex system in 4 dimensional space-time.**
 - Emergent property
 - Strongly interacting
 - **Countless “spontaneous symmetry breakings” during the evolutionary and developing process of life**
 - **Fully controlled experiments by “Virtual Reality” under way.**
 - Outer world (environment) vs. Inner world (brain)
- 
- **“Ultra high-speed optical imaging” may reveal the fundamental principle of the brain function such as consciousness.**

Thanks to all the Collaborators!

Scientific Objectives	Department	Prime PI	Other Senior Person	Grad Students	Sample	High-speed Microscopes	Funding	Activities
Neurophysics (Virtual Reality)	Physics & Astronomy, Neurology	Mayank Mehta		Daniel Aharoni, Bernard Willers	Rat	2PE, Tetrode	Keck Foundation	2009 - Now
Hair cell motion	Physics & Astronomy	Dolores Bozovic		Lea Fredrickson	Frog	CMOS	NSF MRI	2007 - Now
Neutral Networks	Physics & Astronomy	Katsushi Arisaka	Luis Beltran-Parrazal	Adrian Cheng	Zebrafish	2PE, Conforcal	NSF MRI	2008 - 2009
Single Molecule	Chemistry	Shimon Weiss	Xavier Michalet, Adrian Cheng	Daniel Aharoni	Cells	64ch FCS, ALEX	NIH R01	2006 - Now
TfR tracking on Cancer cells	Oncology, Physics & Astronomy	Manuel Penichet, John Miao	Gustavo Helguera, Jose Rodriguez		Cells	CMOS, ICMOS	(NSF MRI shared)	2007 - 2008
Neural networks for breathing	Neurobiology	Jack Feldman	Consuelo Morgado	Adrian Cheng	Rat	ICMOS, Confocal	(NSF MRI shared)	2007 - 2008
Neural networks (Voltage sensing dyes)	Neurobiology	Tom Otis		Bernard Willers	Sliced Brain	ICMOS, 2PE	NIH Rec. Act	2009 - Now
Development of neural networks	Neurology	Carlos Portera-Cailliau	Adrian Cheng, Tiago Goncalves	Phuc Hoang	Mouse	2PE	NIH Rec. Act	2008 - Now
High-speed Imaging Flow Cytometer	Electrical Engineering	Bahram Jalali			Cells	ICMOS		2009 - Now
Core facility of High-speed Bio-imaging	CNSI	Shimon Weiss	Laurent Bentolila		Anything	CMOS, ICMOS, EMCCD	CNSI internal	2008 - Now
Multi-channel HAPD, LCOS	Hamamatsu	Suyama Motohiro				2PE, EMCCD	EMCCD, LCOS donated	2006 - Now
CMOS Camera	Photron	Tak Takimizu				CMOS, ICMOS	3 CMOS donated	2007 - Now
High-speed Microscope	Nikon, Leica	Jeff Huber, Thomas Zhapf				CMOS, ICMOS, 2PE	Microscope discounted	2009 - Now