

# MAX

## Multi-Ton Argon & Xenon

### Katsushi Arisaka

*University of California, Los Angeles  
Department of Physics and Astronomy*

arisaka@physics.ucla.edu

# MAX - Multi-ton Argon & Xenon

MAX Collaboration = DarkSide + XENON

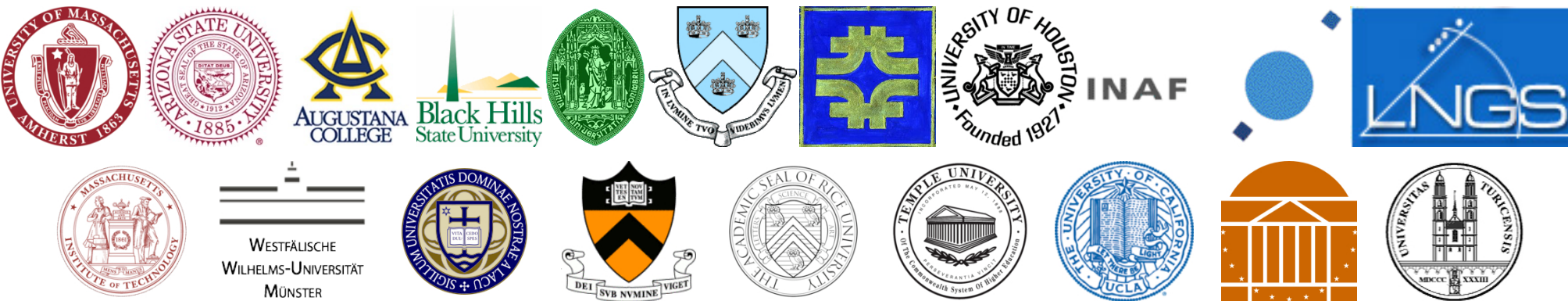

UMass Amherst, Arizona State University,  
Augustana College, Black Hills State University,  
Coimbra University, Columbia University, Fermilab,  
University of Houston, INAF, LNG, MIT, University of Münster,  
University of Notre Dame, Princeton University, Rice University,  
Temple University, UCLA, University of Virginia,  
University of Zürich

# MAX G3 Detector (at DUSEL)

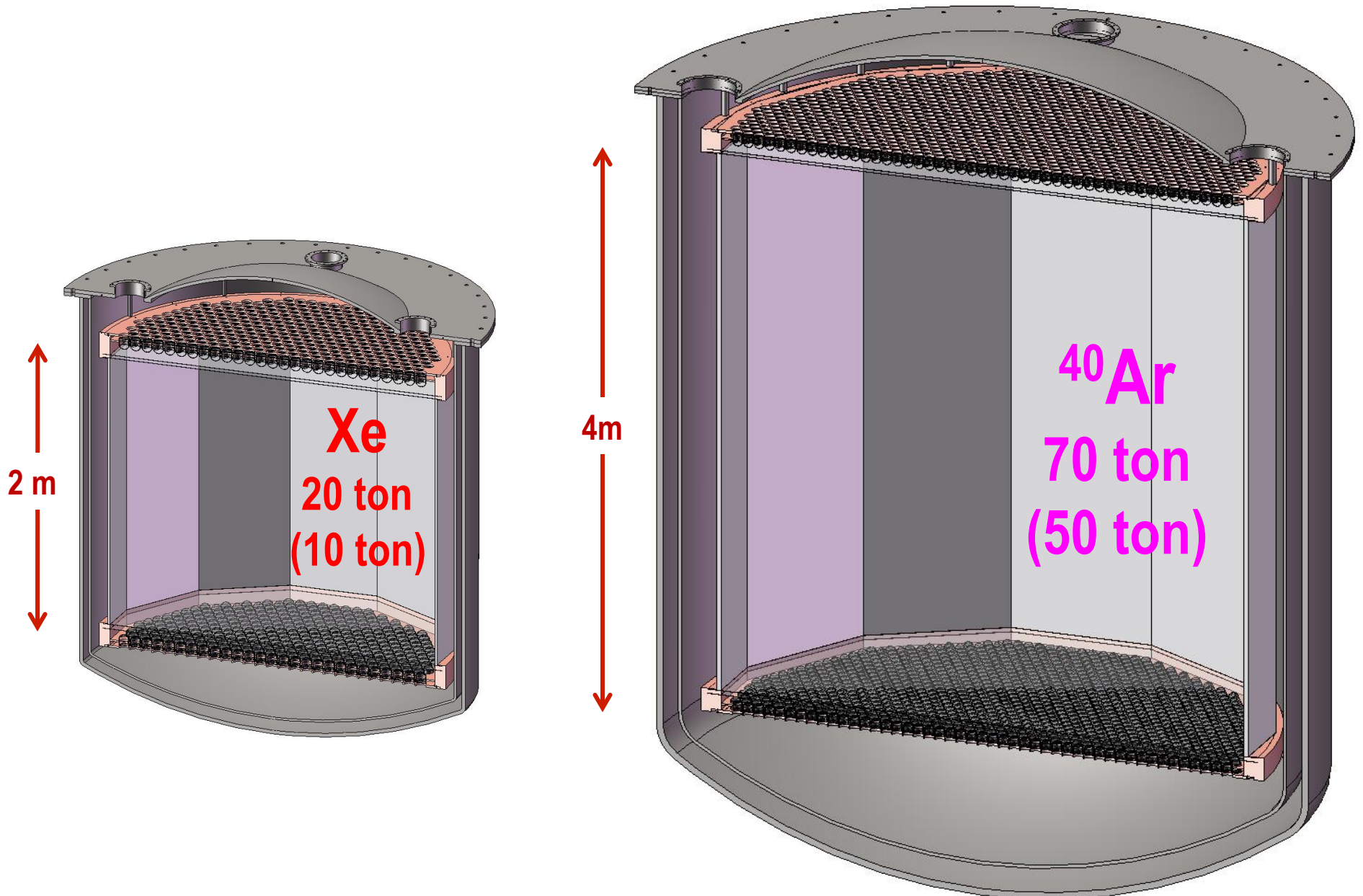

# Roadmap to MAX

2012 2013 2014 2015 2016 2017 2018 2019 2020

Gran Sasso → DUSEL

MAX

XENON100

*(Paul Scovell)*

XENON 1T

*(Elena Aprile)*

Xe 10T

DarkSide50

*(Luca Grandi, Frank Calaprice)*

DarkSide 5T

Ar 50T

G1

G2

G3

WIMP-Nucleon Cross Section [ $\text{cm}^2$ ]

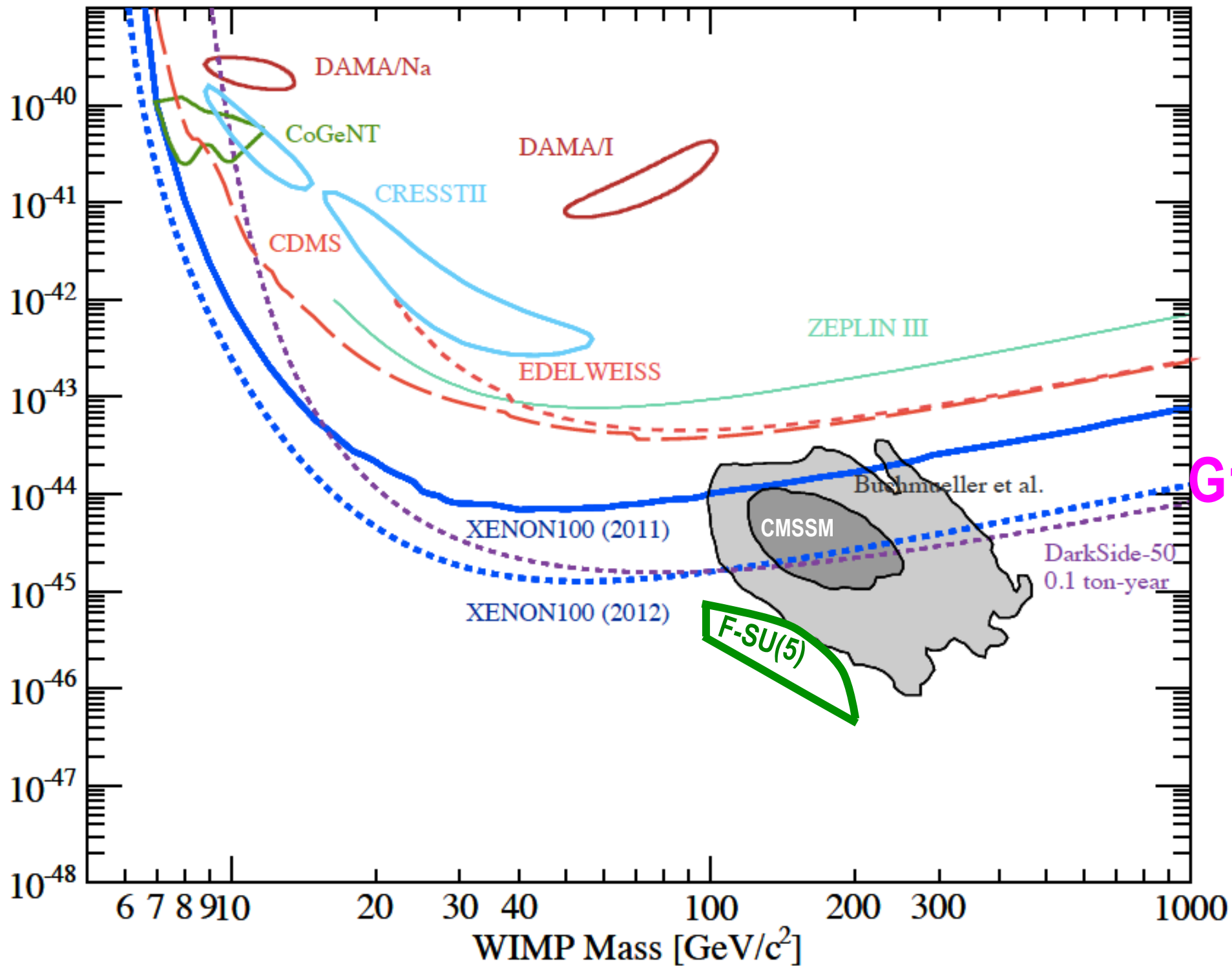

WIMP-Nucleon Cross Section [ $\text{cm}^2$ ]

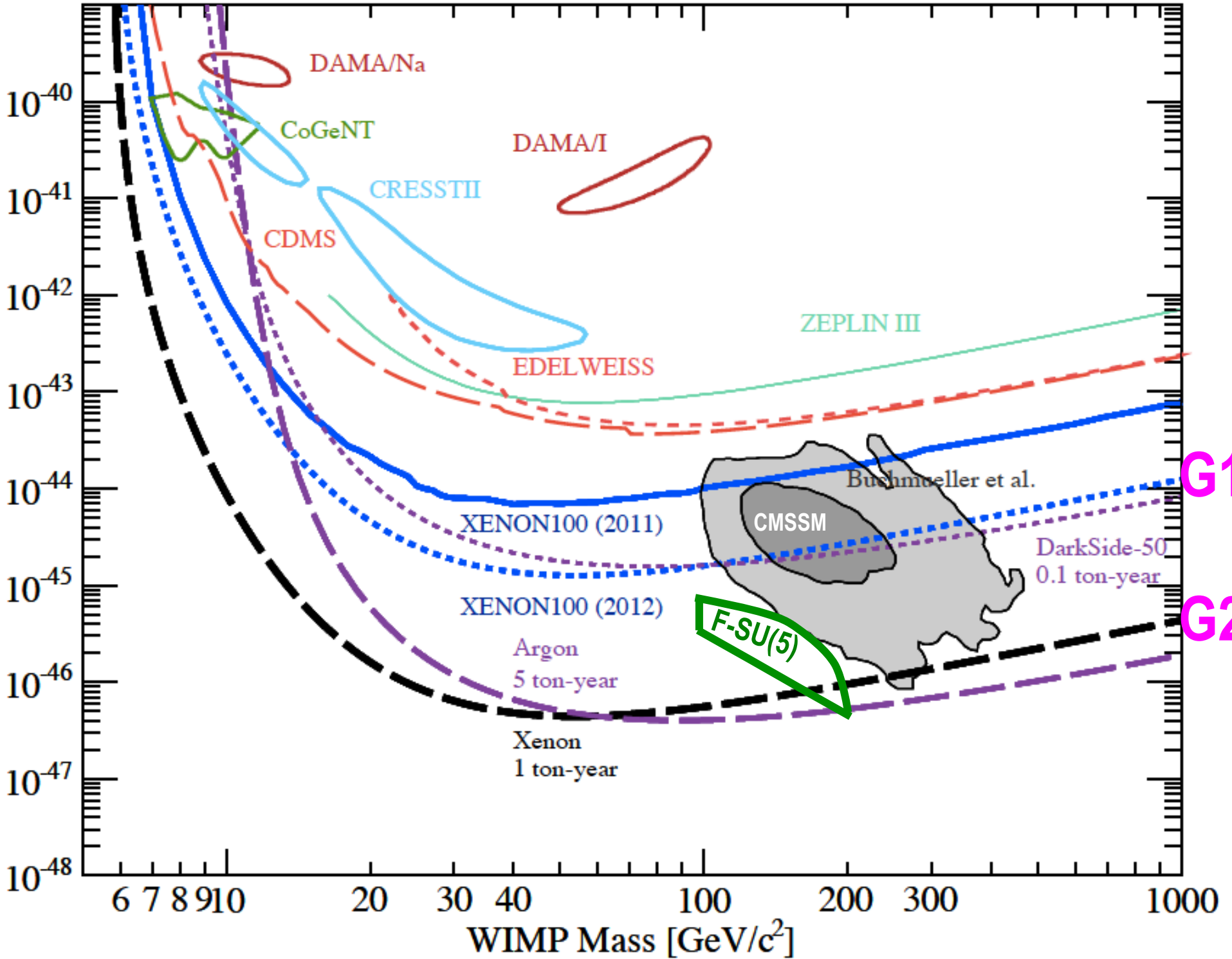

WIMP-Nucleon Cross Section [ $\text{cm}^2$ ]

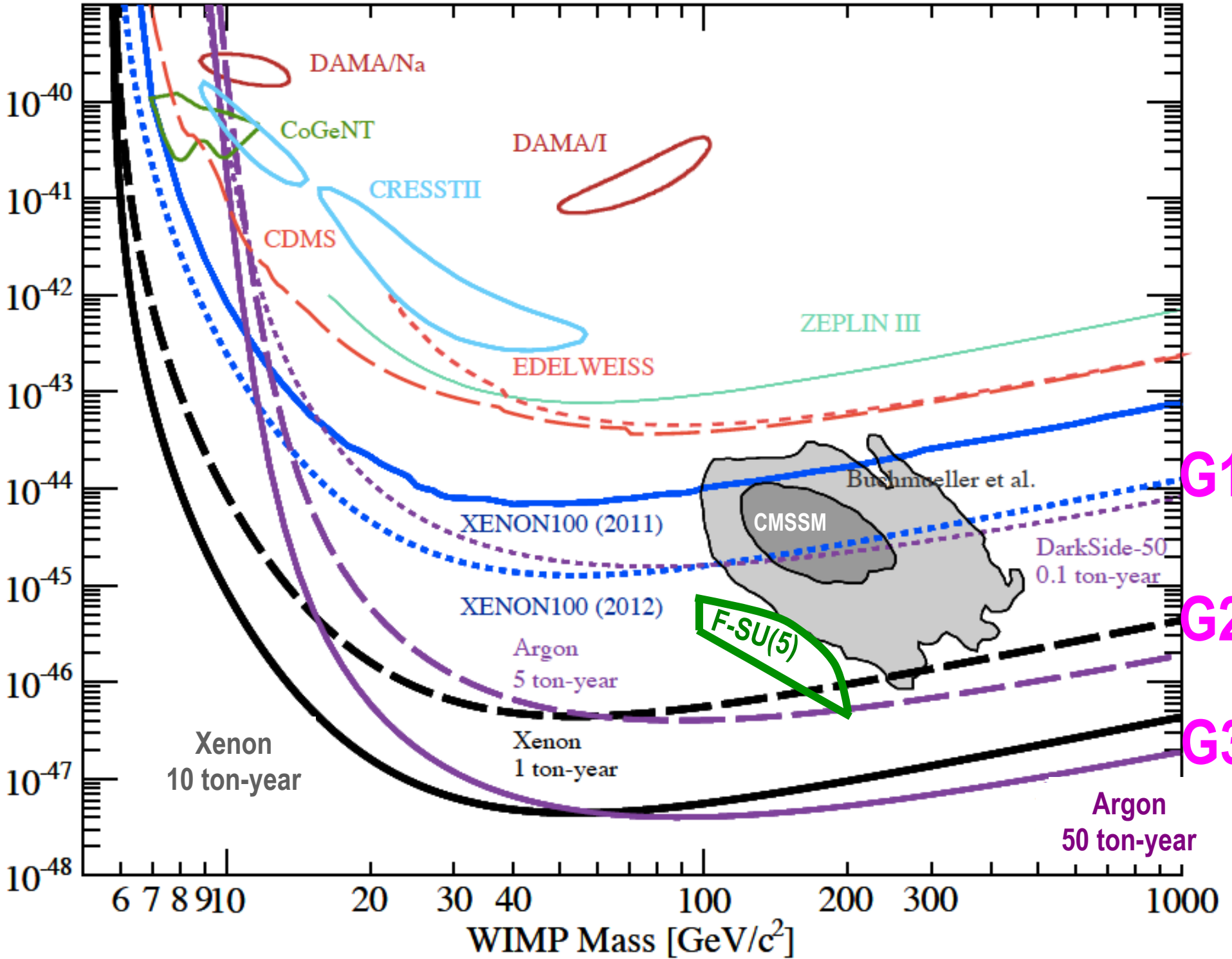

WIMP Mass [ $\text{GeV}/c^2$ ]

# (SI) WIMP Energy Spectrum for LXe (Cross Section = $10^{-45}\text{cm}^2$ )

(SI) WIMP Recoil Energy Spectrum for LXe ( $\sigma = 10^{-45}\text{cm}^2$ )

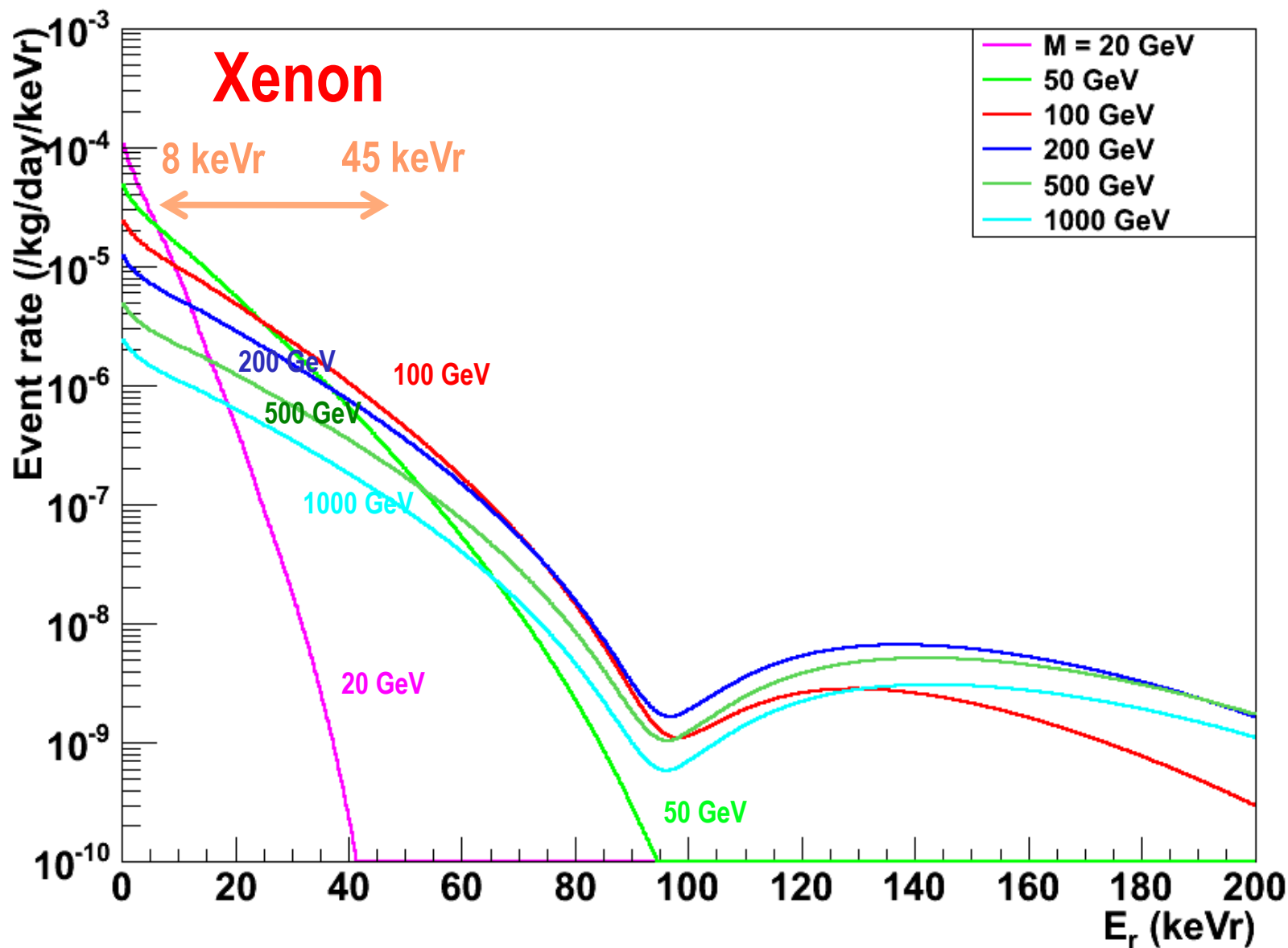

# (SI) WIMP Energy Spectrum for LAr (Cross Section = $10^{-45}\text{cm}^2$ )

(SI) WIMP Recoil Energy Spectrum for LAr ( $\sigma = 10^{-45}\text{cm}^2$ )

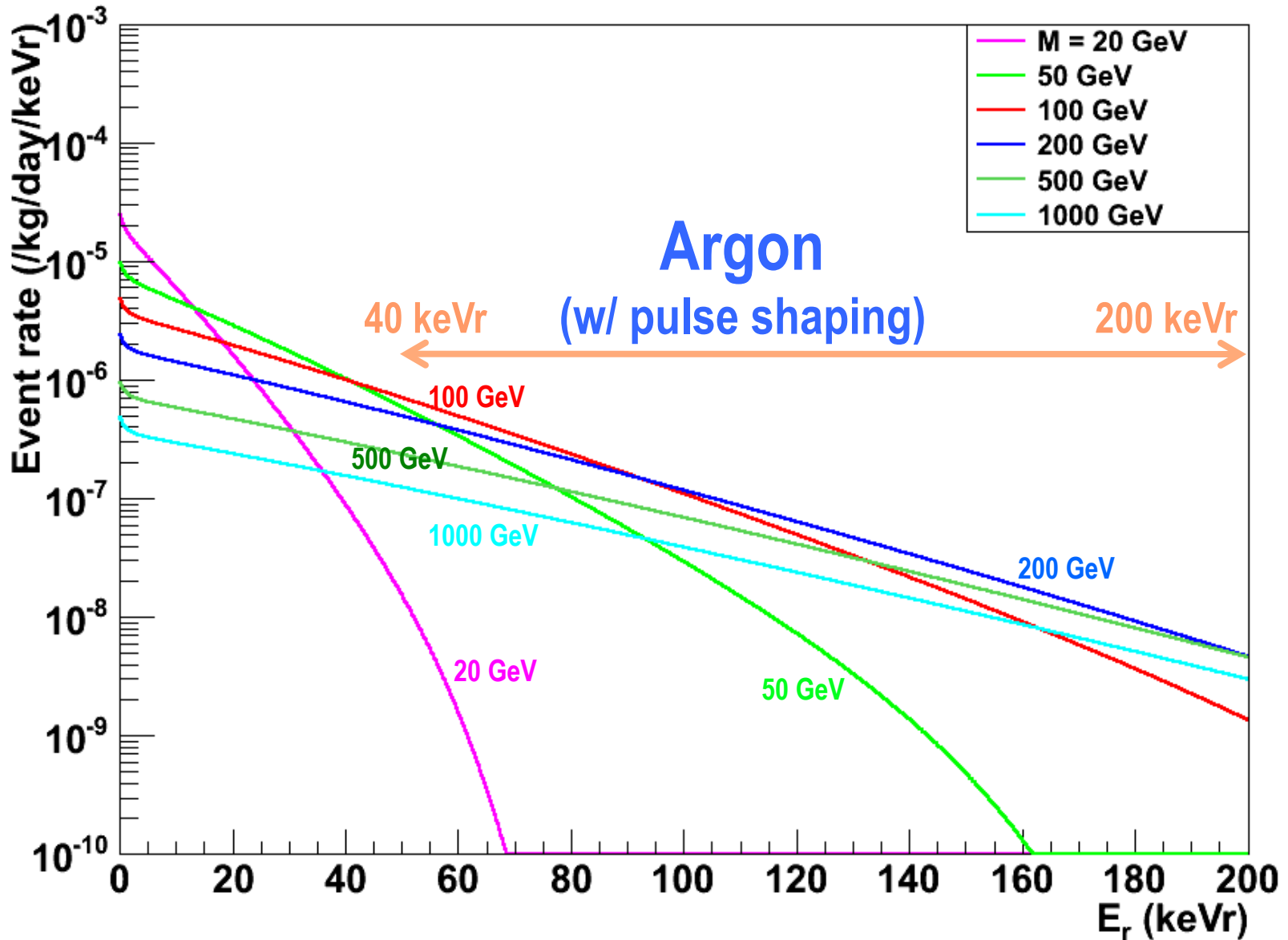

# 1- $\sigma$ Error of WIMP Mass vs SI Cross Section (10 ton\*year Xe and 50 ton\*year Ar)

1- $\sigma$  Error of WIMP Mass and SI Cross Section

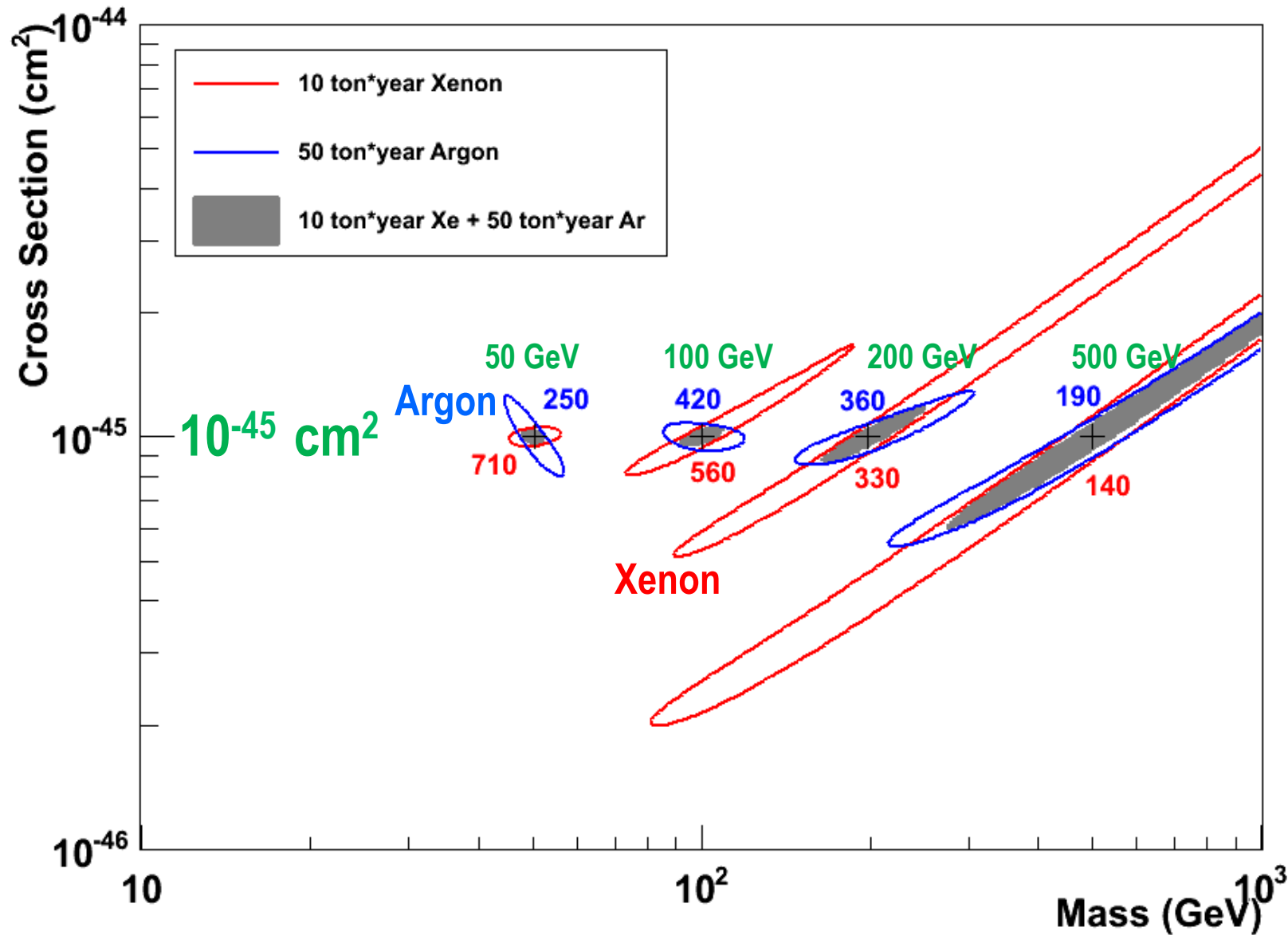

# 1- $\sigma$ Error of WIMP Mass vs SI Cross Section (10 ton\*year Xe and 50 ton\*year Ar)

1- $\sigma$  Error of WIMP Mass and SI Cross Section

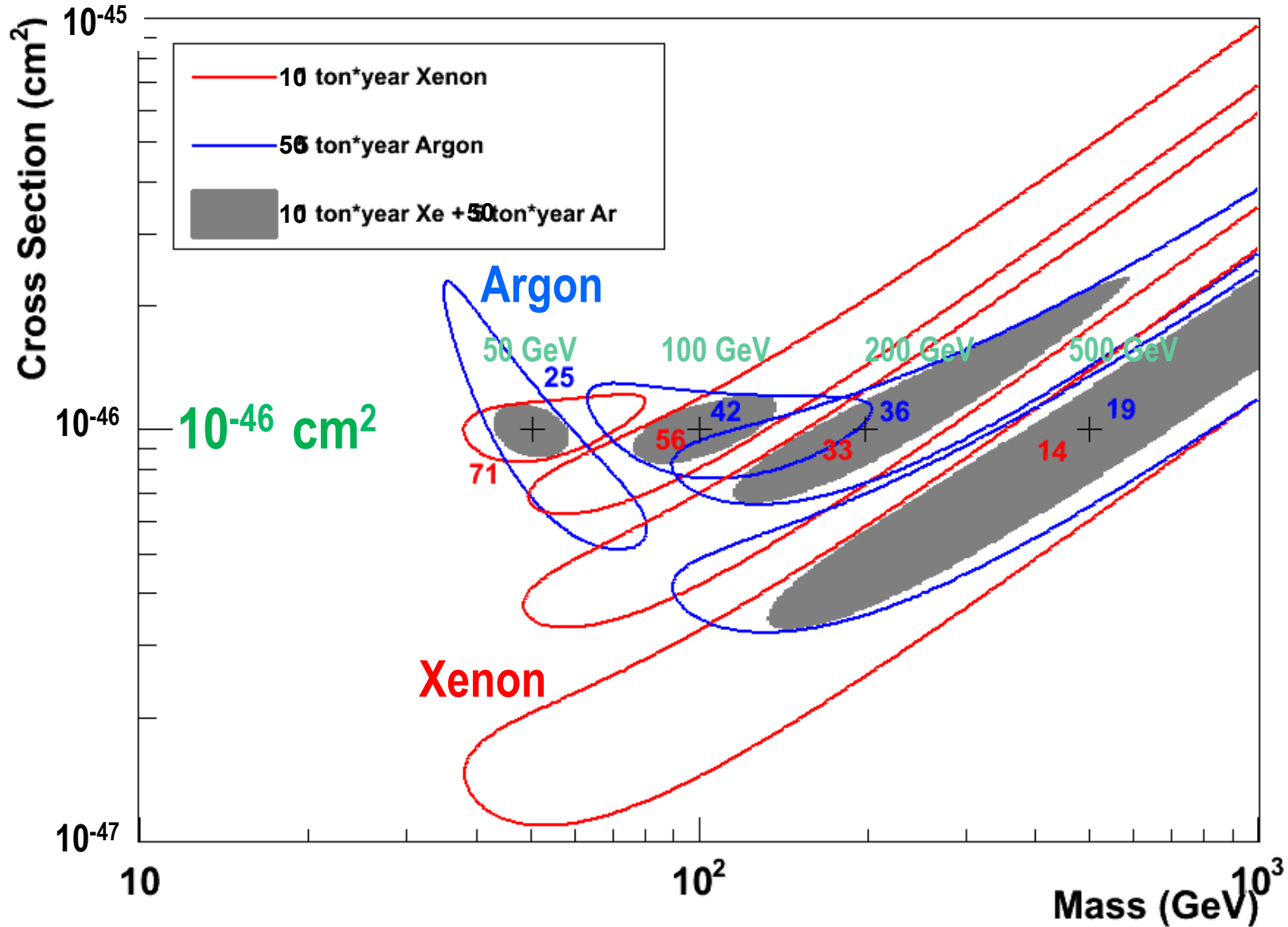

# 1- $\sigma$ Error of WIMP Mass vs SI Cross Section (10 ton\*year Xe and 50 ton\*year Ar)

1- $\sigma$  Error of WIMP Mass and SI Cross Section

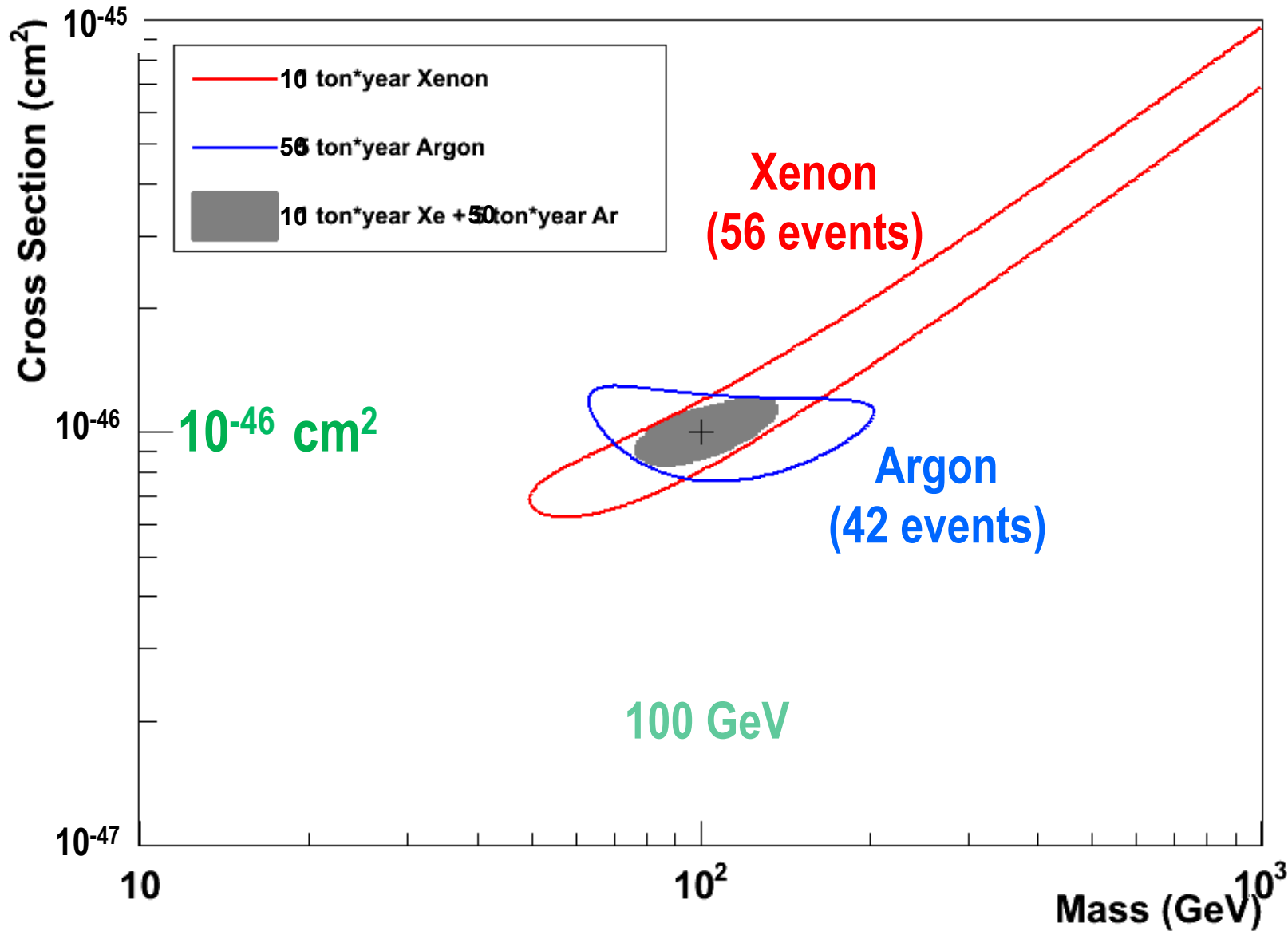

# 1- $\sigma$ Error of WIMP Mass vs SI Cross Section (10 ton\*year Xe and 50 ton\*year Ar)

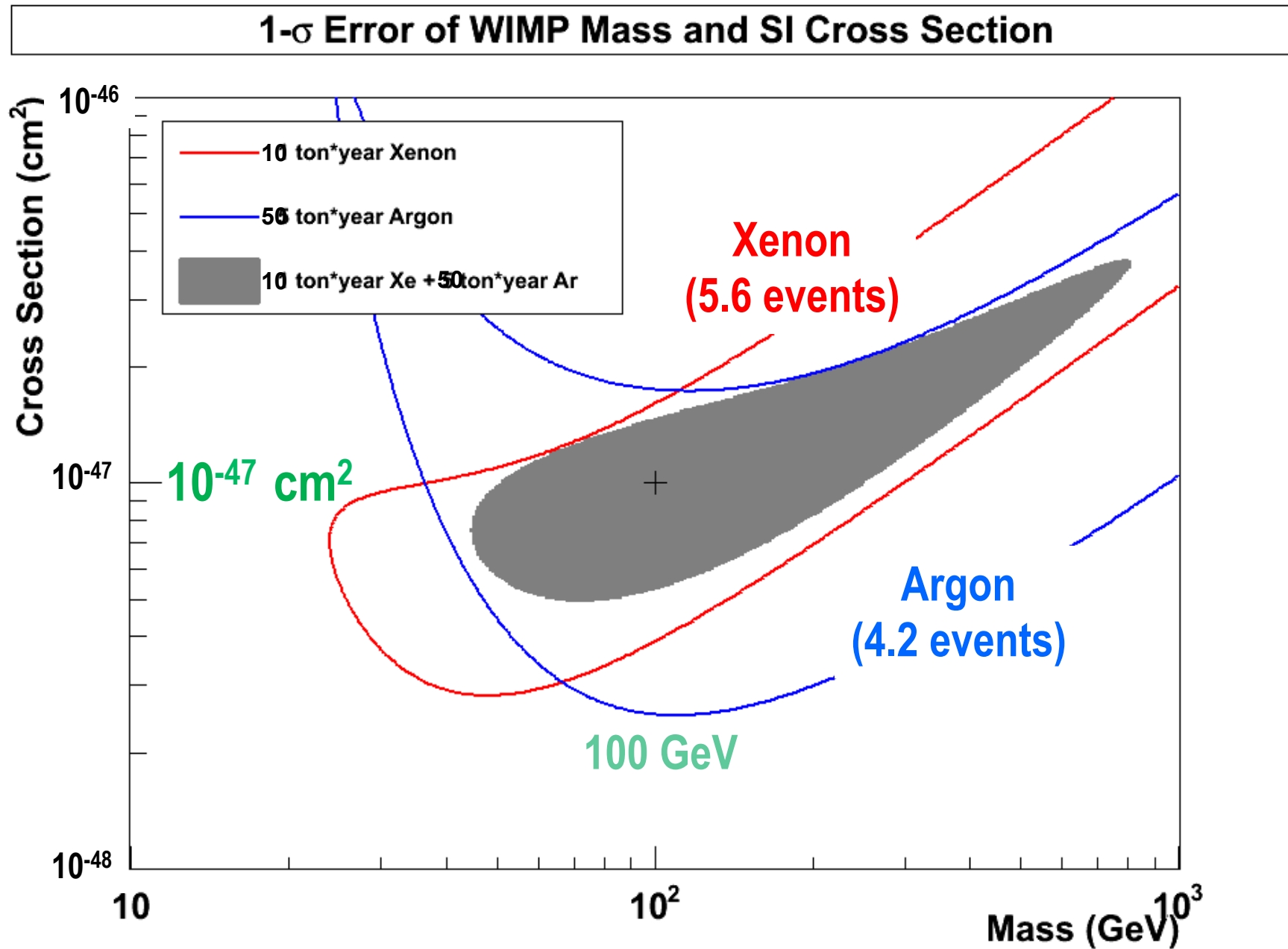

# (SI) WIMP Energy Spectrum for LXe (Cross Section = $10^{-45} \text{cm}^2$ )

(SI) WIMP Recoil Energy Spectrum for LXe ( $\sigma = 10^{-45} \text{cm}^2$ )

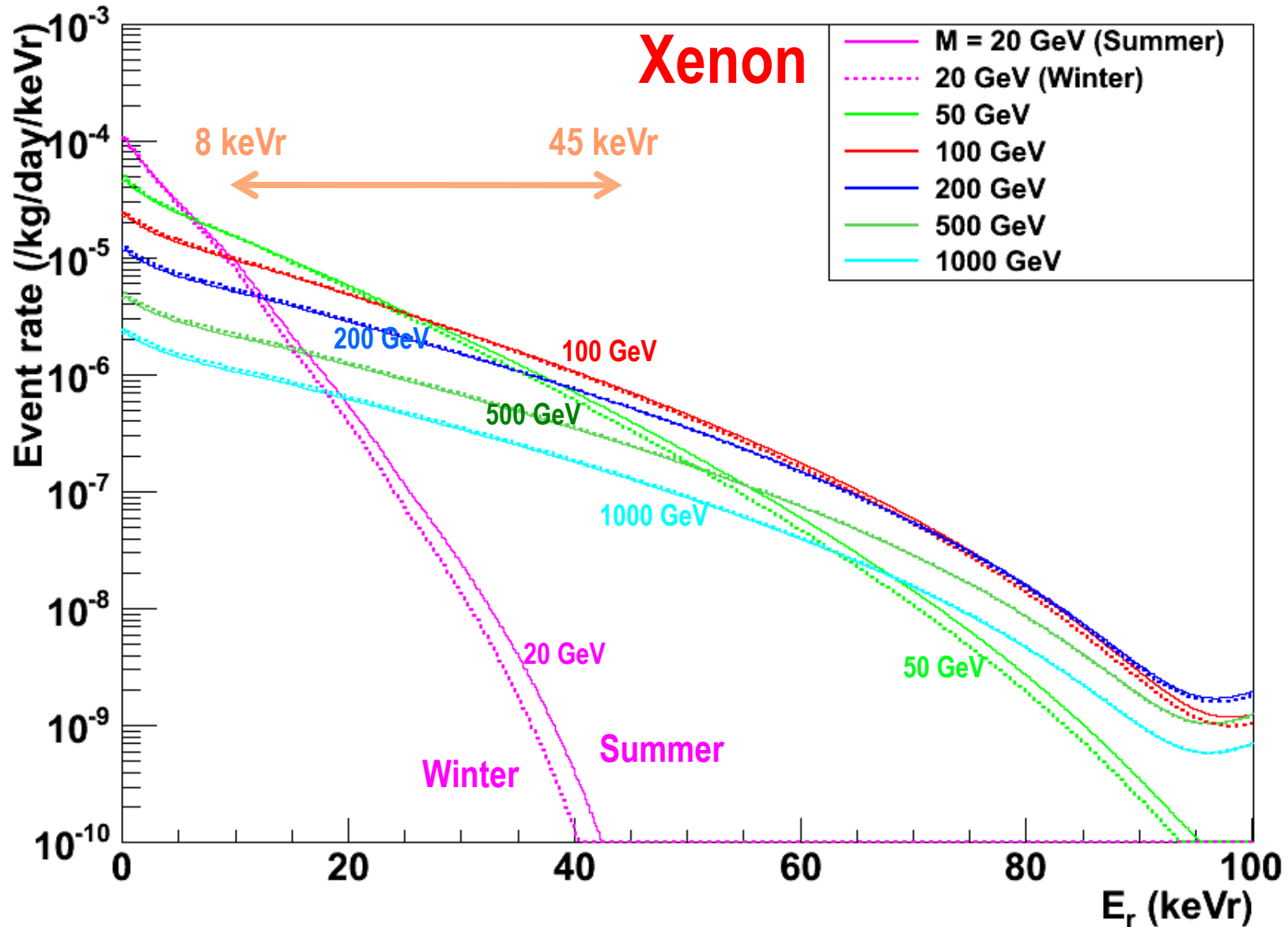

# (SI) WIMP Energy Spectrum for LAr (Cross Section = $10^{-45} \text{cm}^2$ )

(SI) WIMP Recoil Energy Spectrum for LAr ( $\sigma = 10^{-45} \text{cm}^2$ )

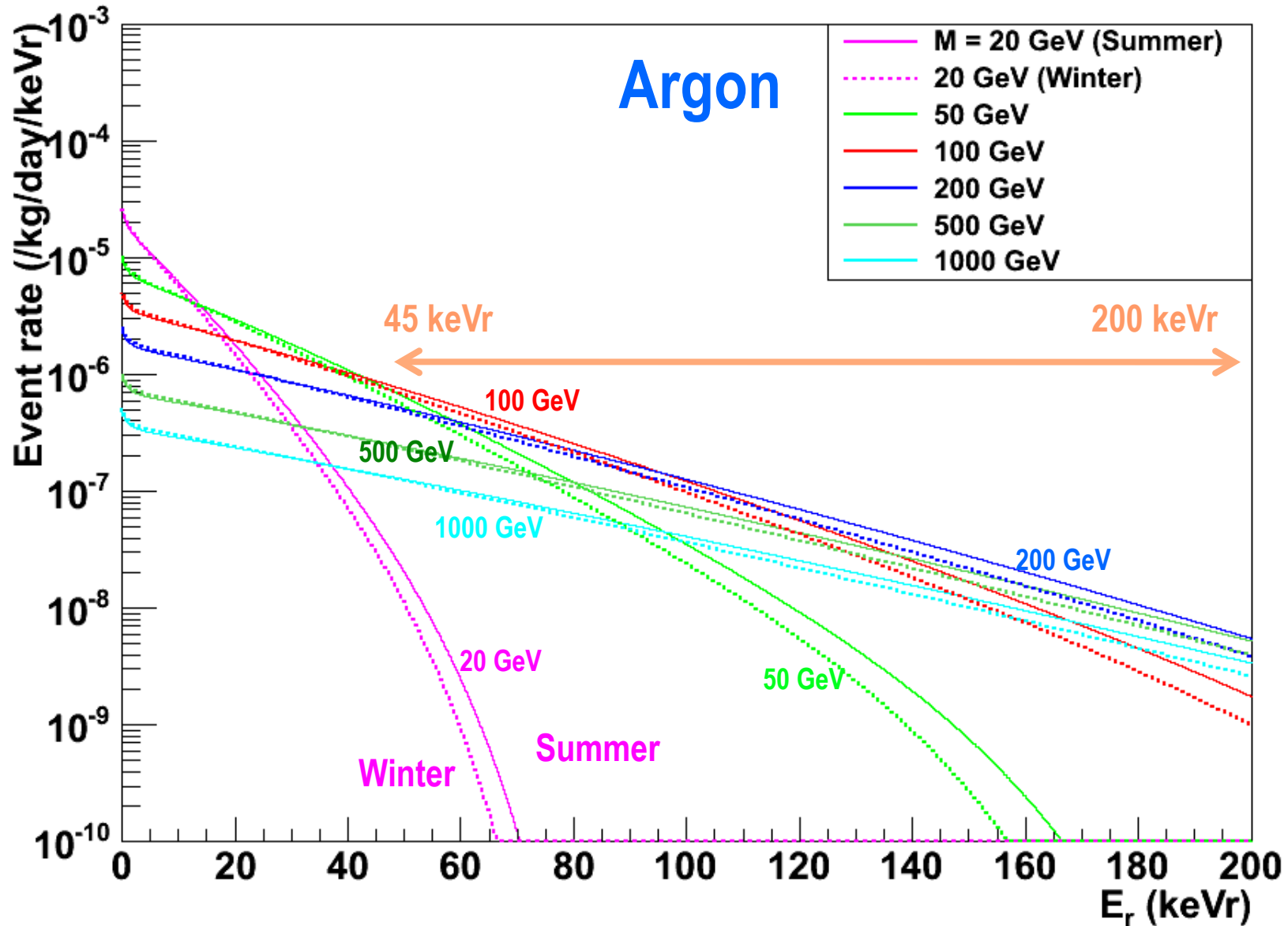

# $\pm 1\sigma$ Error of Annual Modulation Amplitude vs WIMP Mass (10 ton\*year Xe and 50 ton\*year Ar, Cross Section = $10^{-45}\text{cm}^2$ )

1-Sigma Error of Annual Modulation Amplitude vs WIMP Mass ( $\sigma = 1\text{E-}45\text{cm}^2$ )

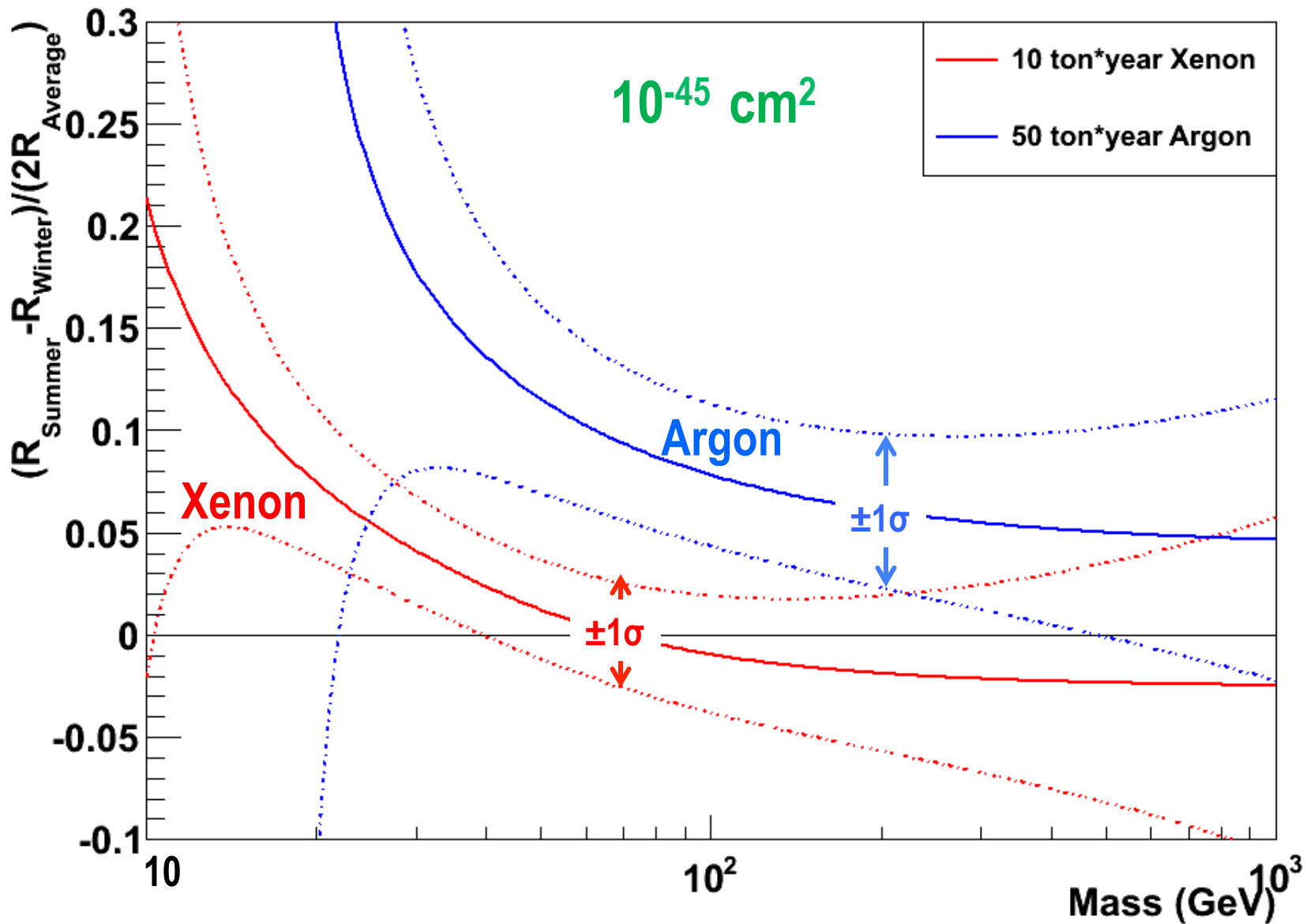

# $\pm 1\sigma$ Error of Annual Modulation Amplitude vs WIMP Mass (10 ton\*year Xe and 50 ton\*year Ar, Cross Section = $10^{-44}\text{cm}^2$ )

1-Sigma Error of Annual Modulation Amplitude vs WIMP Mass ( $\sigma = 1\text{E-}44\text{cm}^2$ )

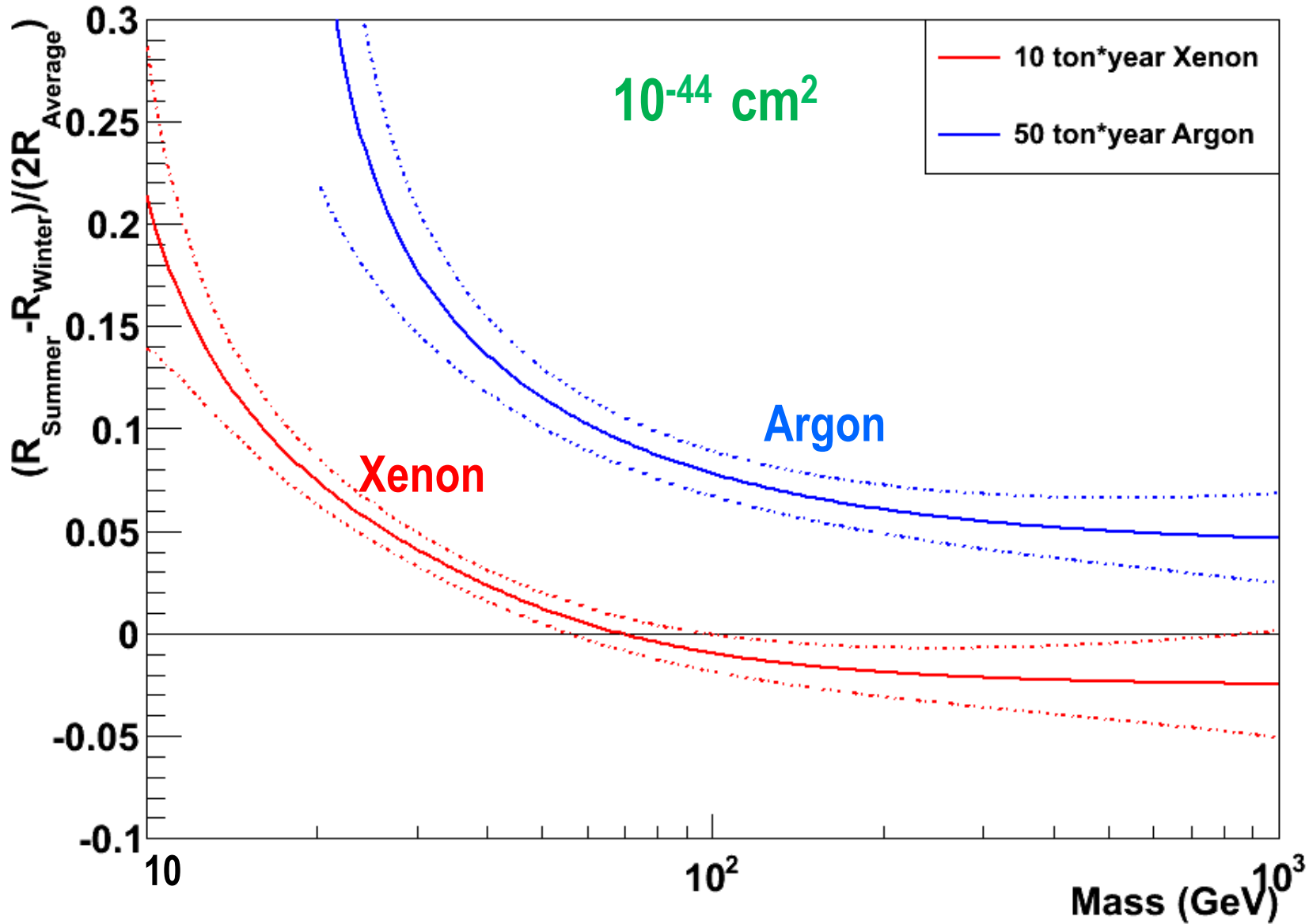

# $\pm 1 \sigma$ Error of Annual Modulation Amplitude for various WIMP velocities (50 ton\*year Ar, Cross Section = $10^{-44} \text{cm}^2$ )

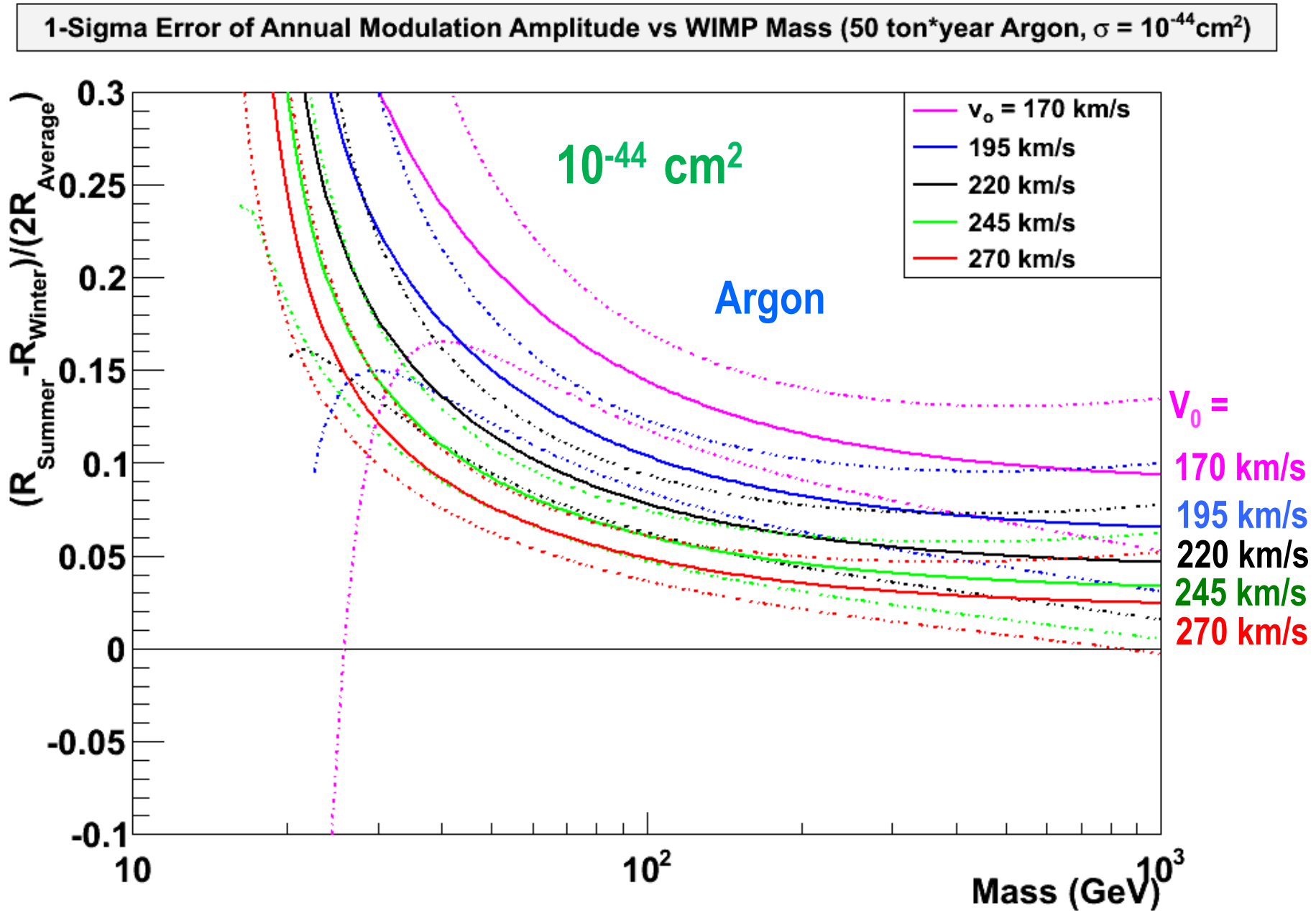

# Technological Challenges

## ➤ External Backgrounds

- Deep underground
- > 5 m water shielding

- DUSEL 4850 ft
- Water Tank (15 m)

## ➤ Detector Materials

- Photon Detectors
- Cryostat
- Others

- QUPID
- Titanium
- Copper, PTFE...

## ➤ Purity of Liquid Xe/Ar

- Radon (< 0.3 mBq / ton)
- $^{39}\text{Ar}$  (> 100 depletion)
- $^{85}\text{K}$  (< 0.2 ppt in Xe)

- Depleted Ar
- 1 event / 10 ton-year

## ➤ Physics Backgrounds in Xe

- pp-chain solar neutrinos
- 2v Double beta decays from  $^{136}\text{Xe}$

- 1 event / 10 ton-year
- 1 event / 10 ton-year

## ➤ Neutron Active Veto

- Boron doped Liquid Scintillator

# QUPID (QUartz Photon Intensifying Detector)

arXiv:1103.3689

Photo Cathode  
(-6 kV)

Quartz

Al coating

APD (0 V)

Quartz

Photo Cathode  
(-6 kV)

APD (0 V)

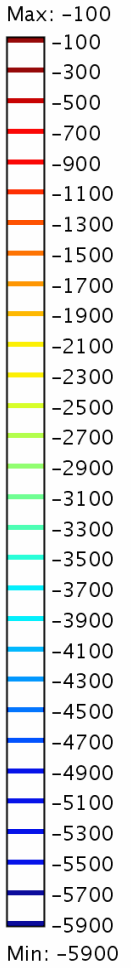

# Comparison of Low-radioactive Photon Detectors from Hamamatsu

R8520  
1 inch

~ 1 mBq

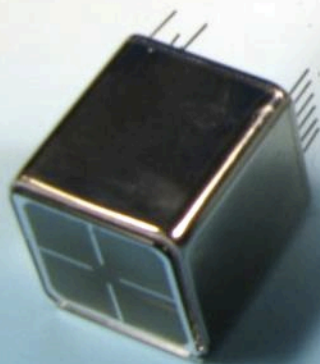

R8778  
2 inch

~ 10 mBq

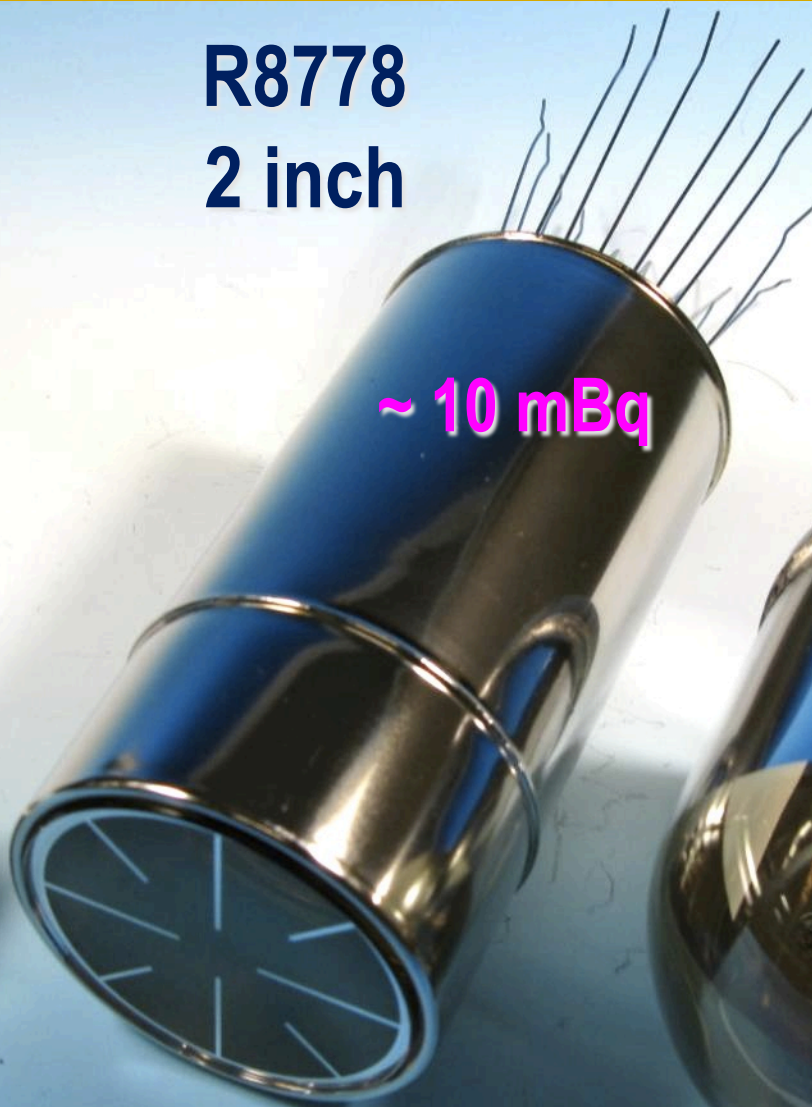

QUPID  
3 inch

< 0.3 mBq



XENON10  
XENON100

LUX  
(XMASS)

DarkSide50  
XENON1T  
MAX, XAY

# QE of two types of QUPID

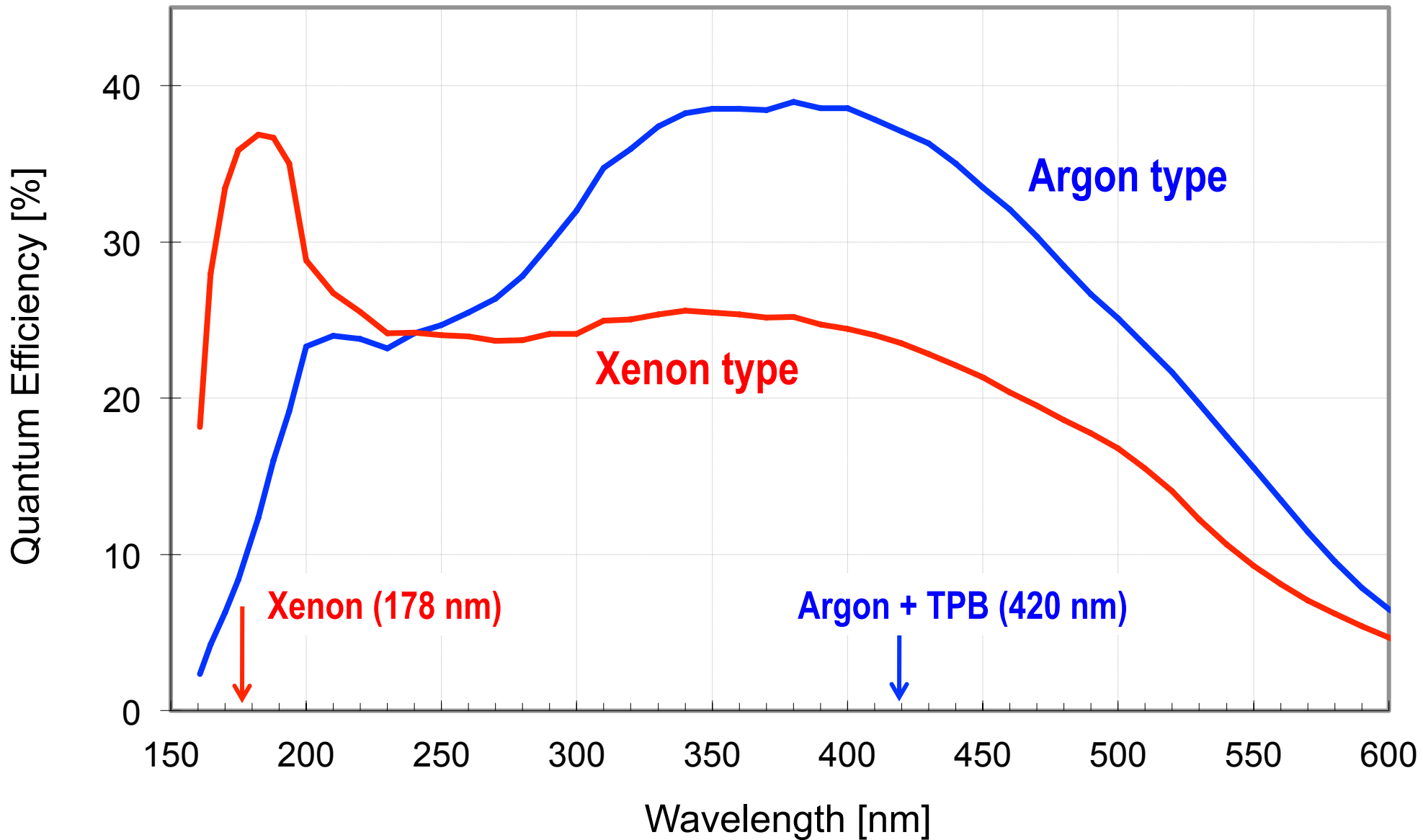

# 1, 2 and 3 PE Distribution with 2 m cable

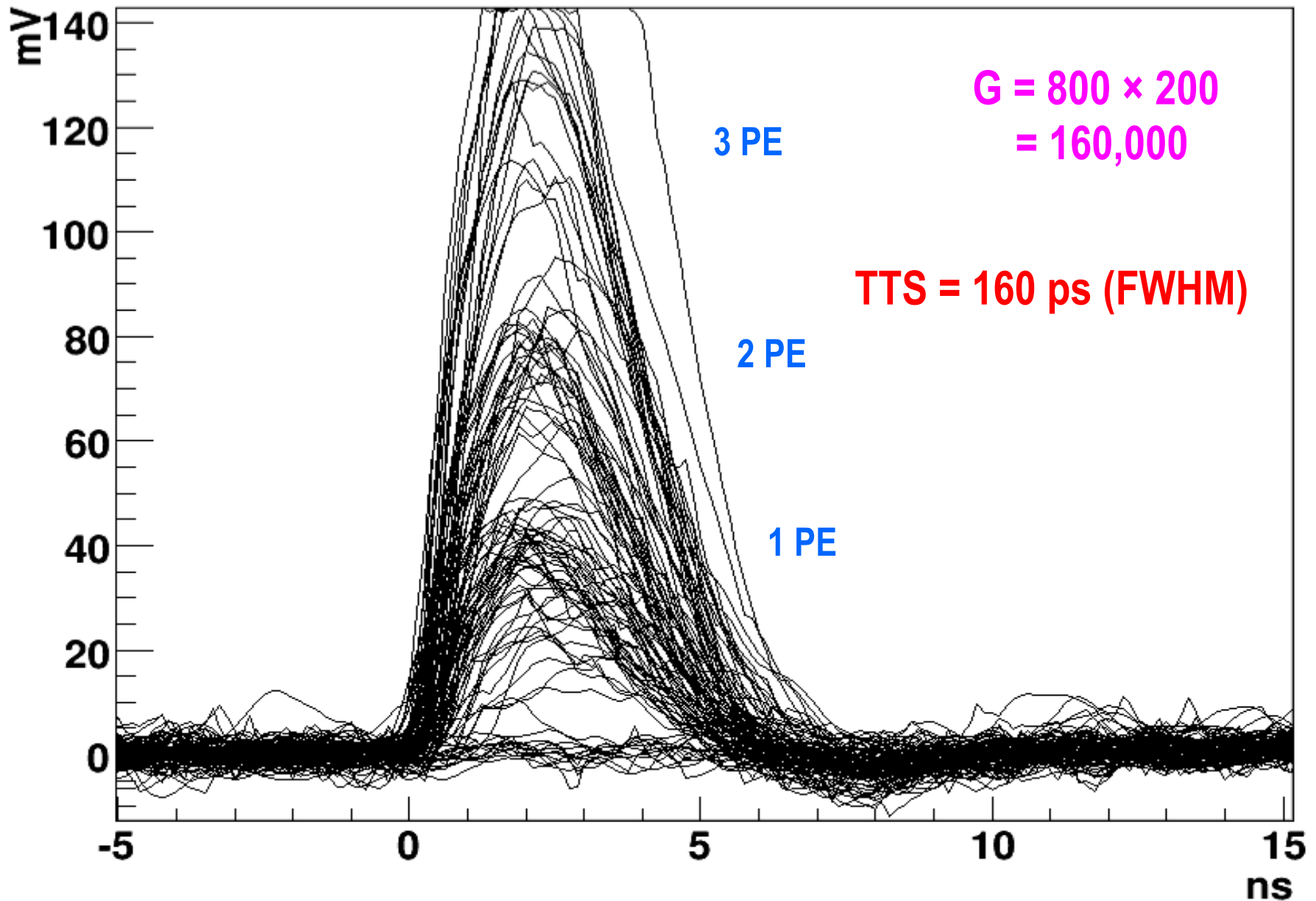

# 7 QUPID with Holder



**Tested in both Xe and Ar at UCLA**  
**Ready for DarkSide 10**

# Xe 10 ton Neutron Background (100 Years)

arXiv:1107.1295

Before Cuts

1/8

Multi Hit Cut

1/4

Liquid Scinti. Veto

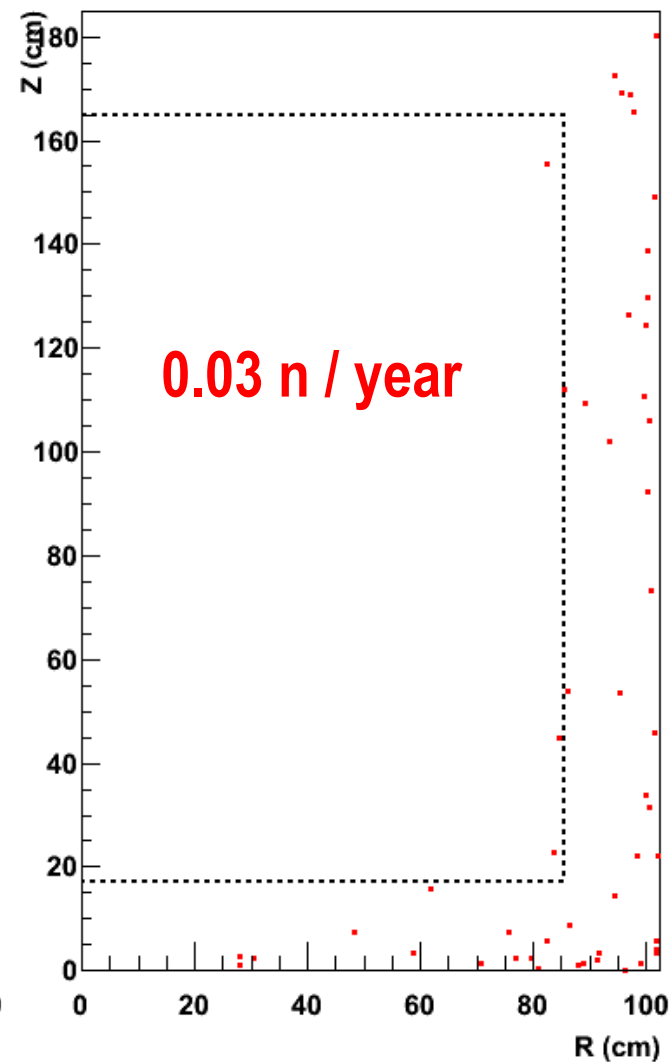
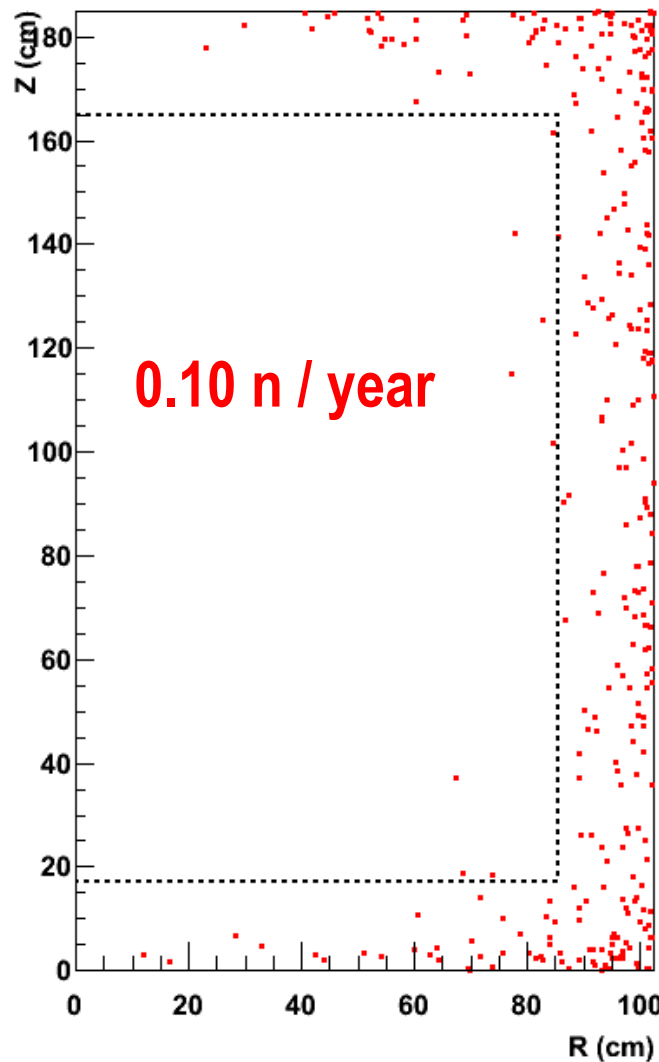
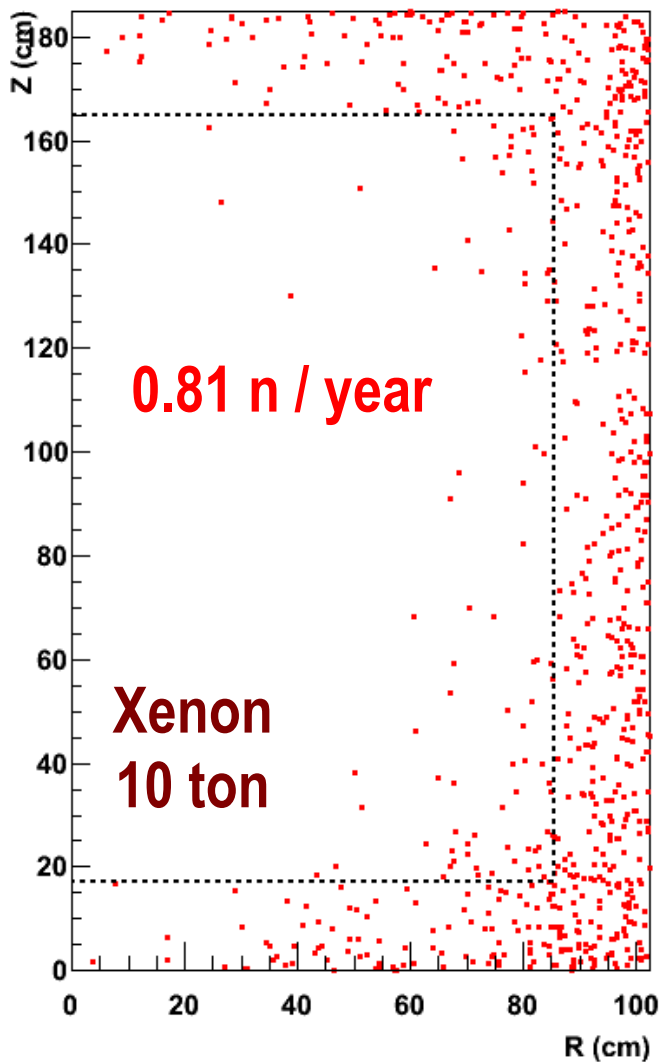

# Ar 50 ton Neutron Background (100 Years)

arXiv:1107.1295

Before Cuts

1/20

Multi Hit Cut

1/6

Liquid Scinti. Veto

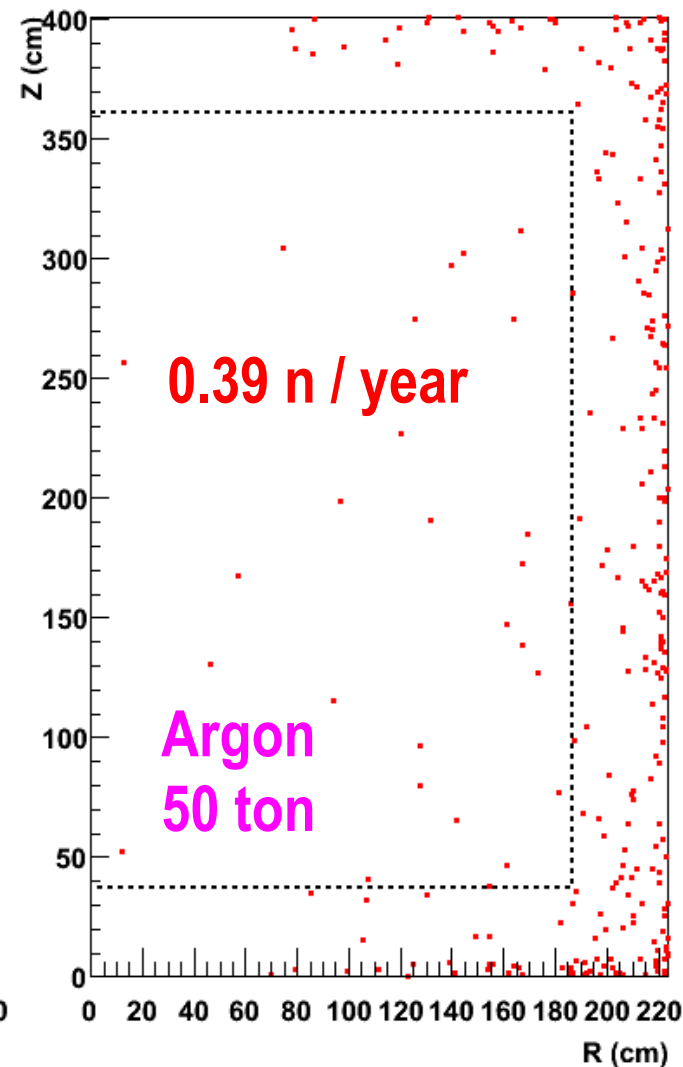
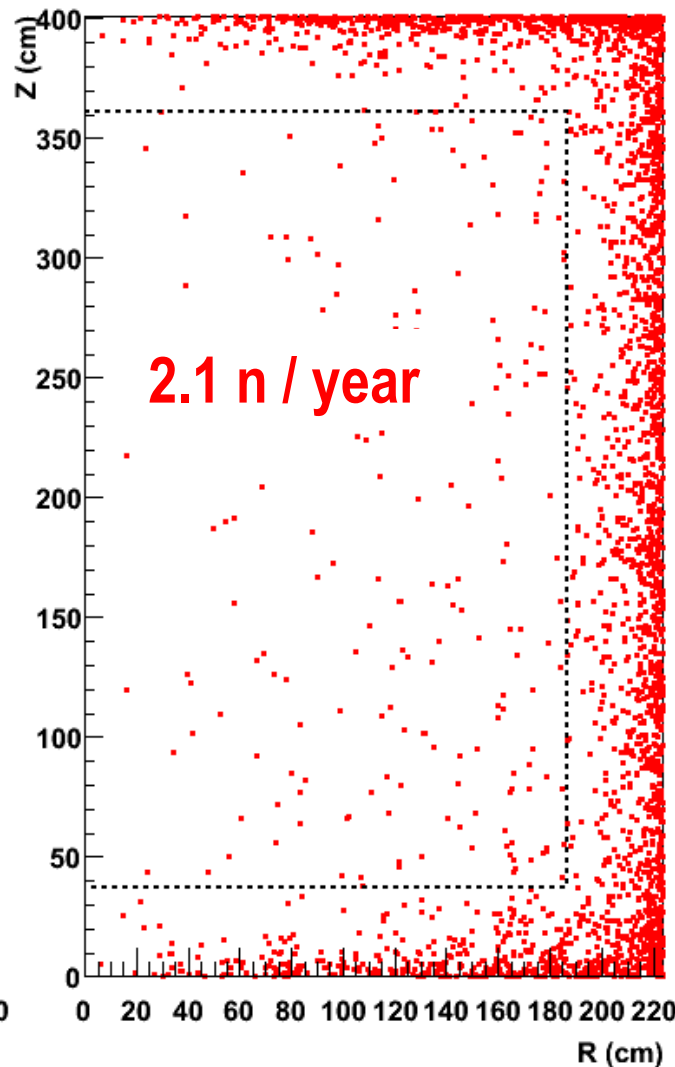
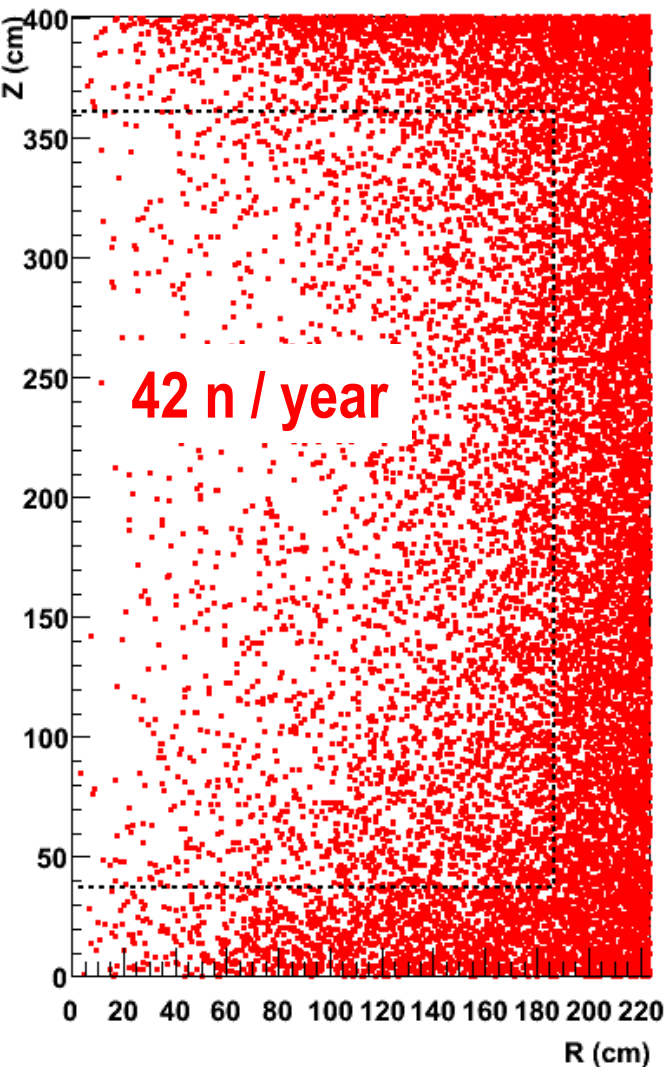

# XAX (Xenon-Argon-Xenon)

arXiv:0808.3968

*WIMP (Spin even)  
Double Beta Decay*

*WIMP (Spin odd)  
pp Solar Neutrino*

*WIMP (Spin even)*

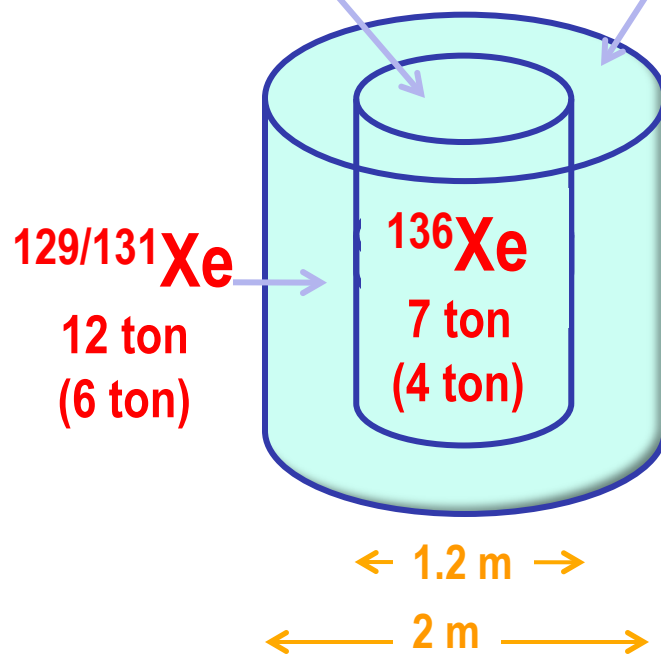

# $^{136}\text{Xe}$ Double Beta Decay and Gamma Background (1 mBq / QUPID, 2m Xenon Detector)

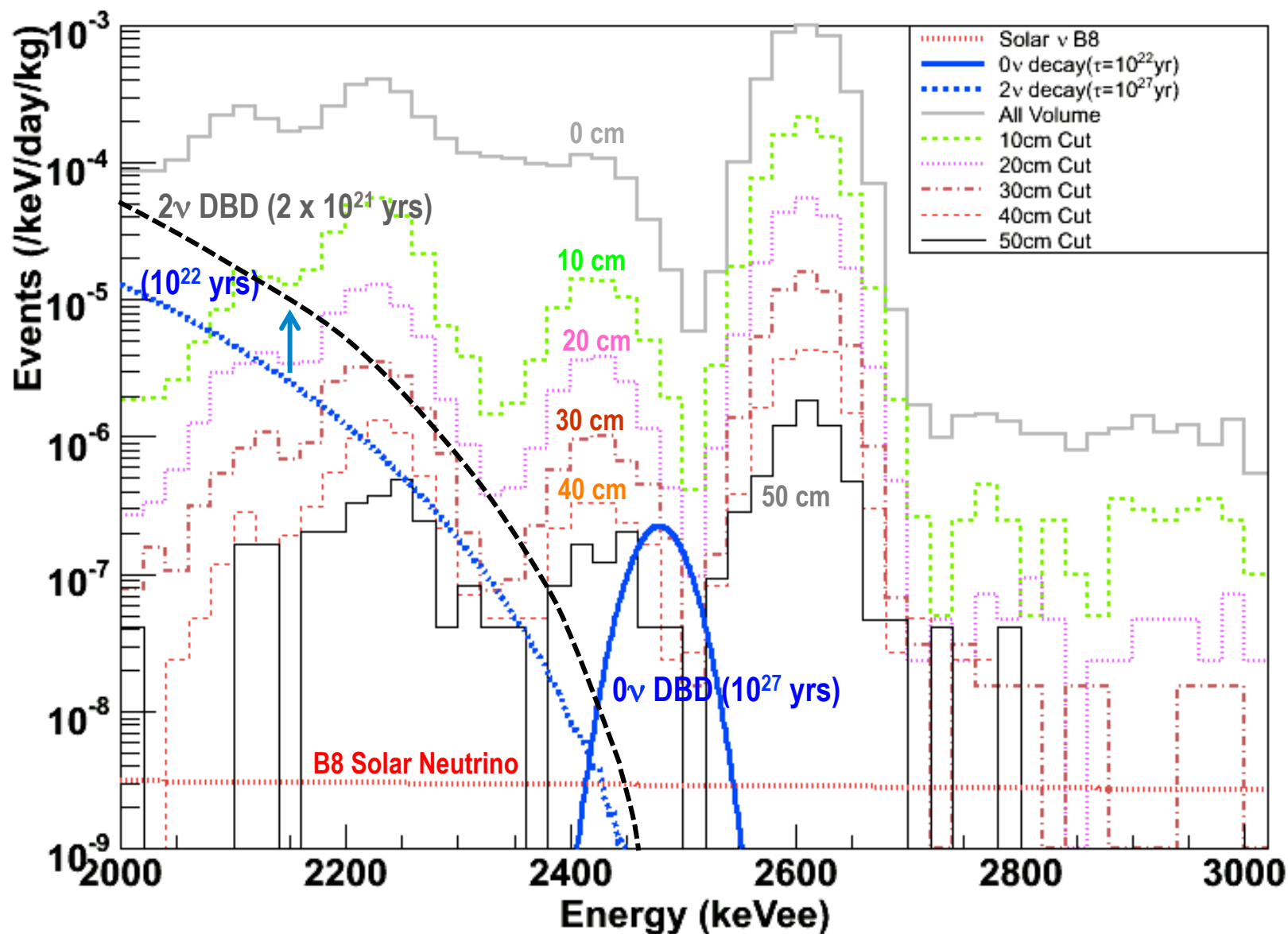

# Double Beta Decay Experiments (with 0.1 mBq QUPID)

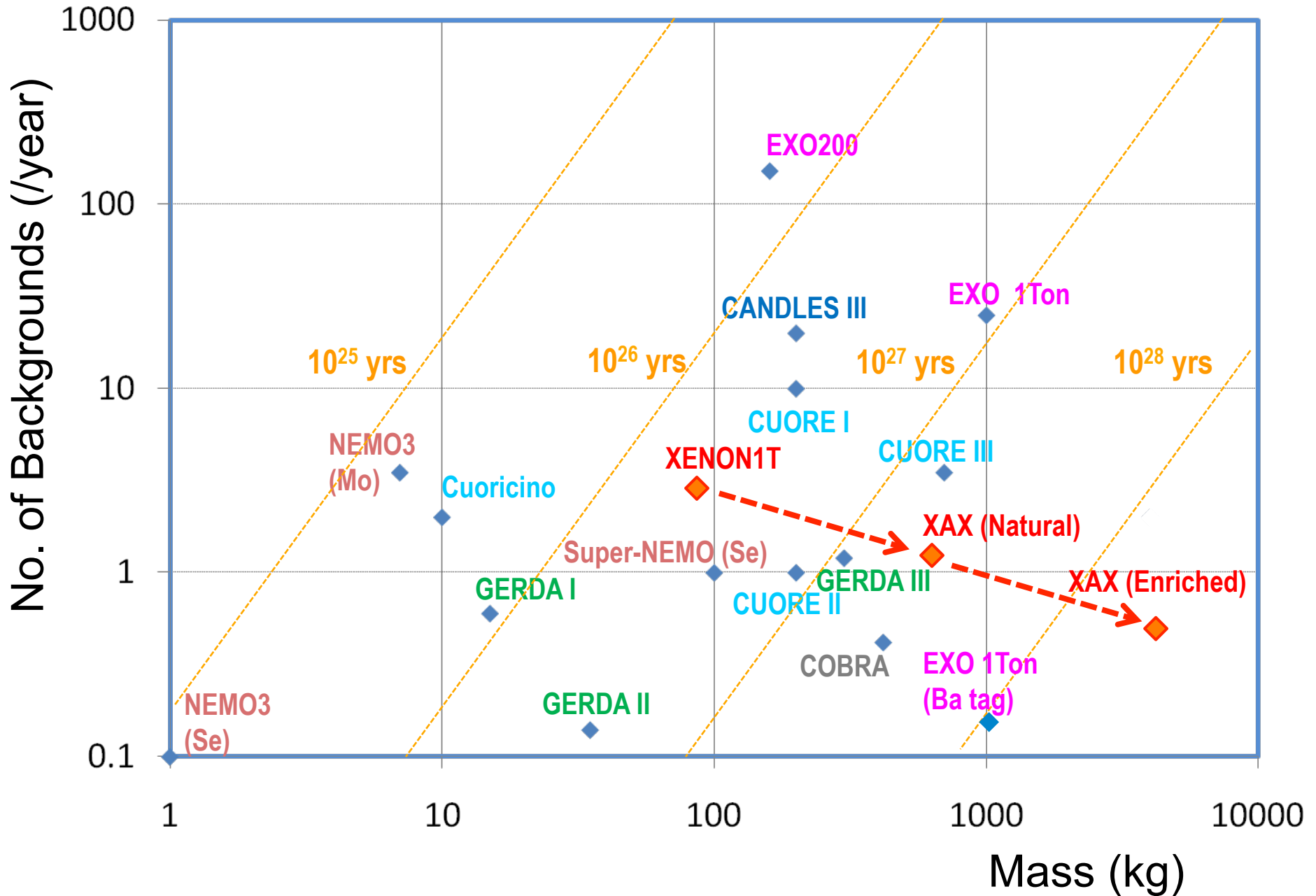

# MAX G3 Detector (at DUSEL)

Xe 20 ton (10 ton)

$^{40}\text{Ar}$  70 ton (50 ton)

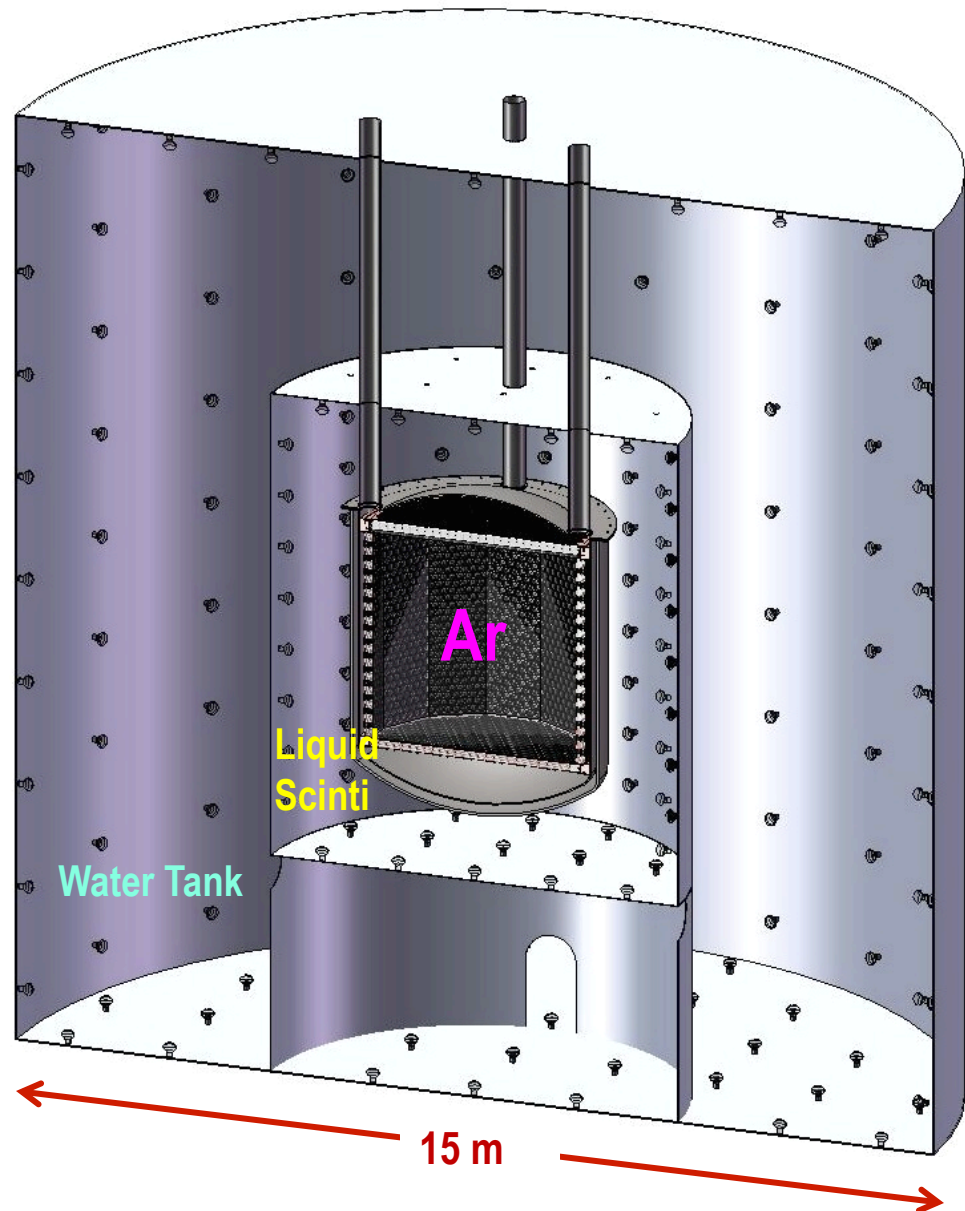
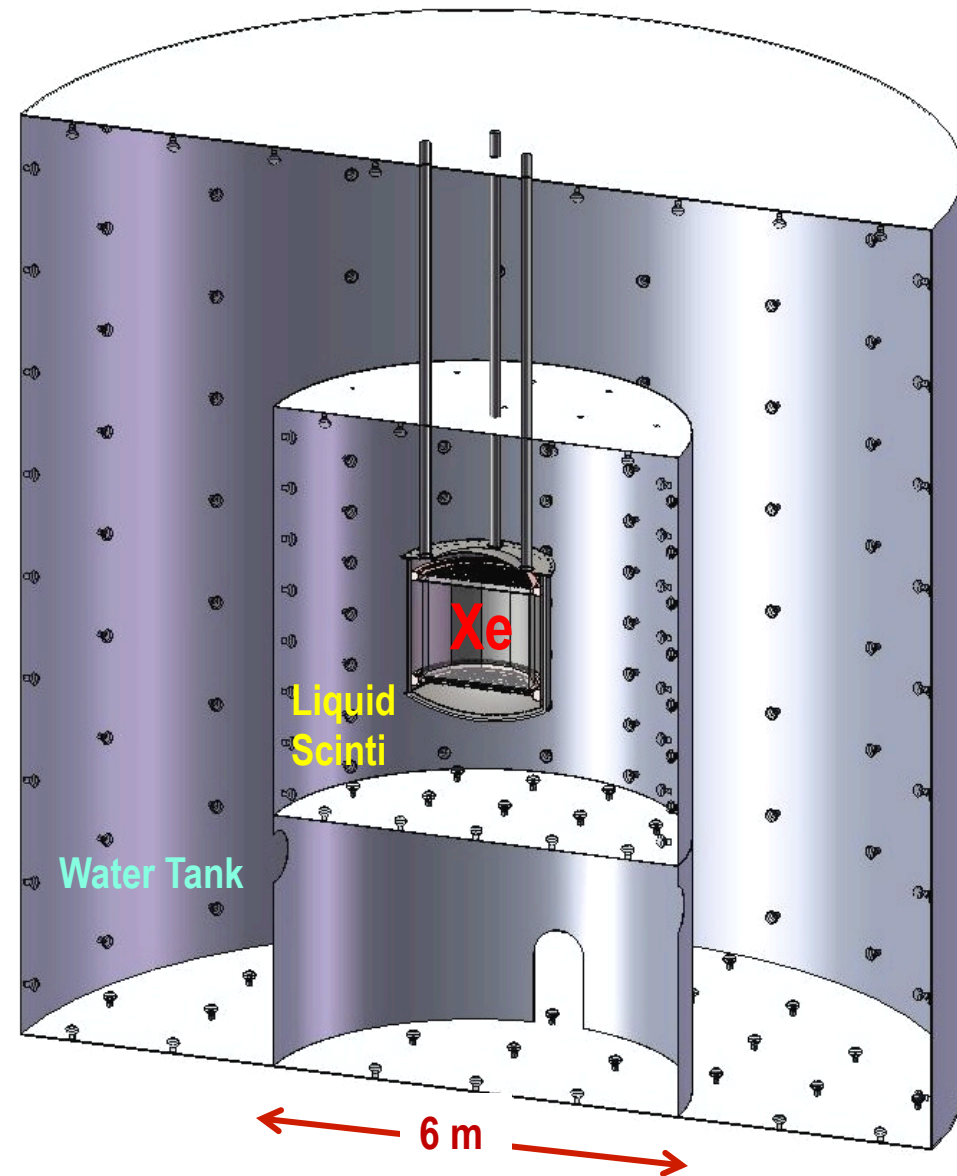

# MAX G3 Detector (at DUSEL)

MAX Layout in  
Homestake 4850ft

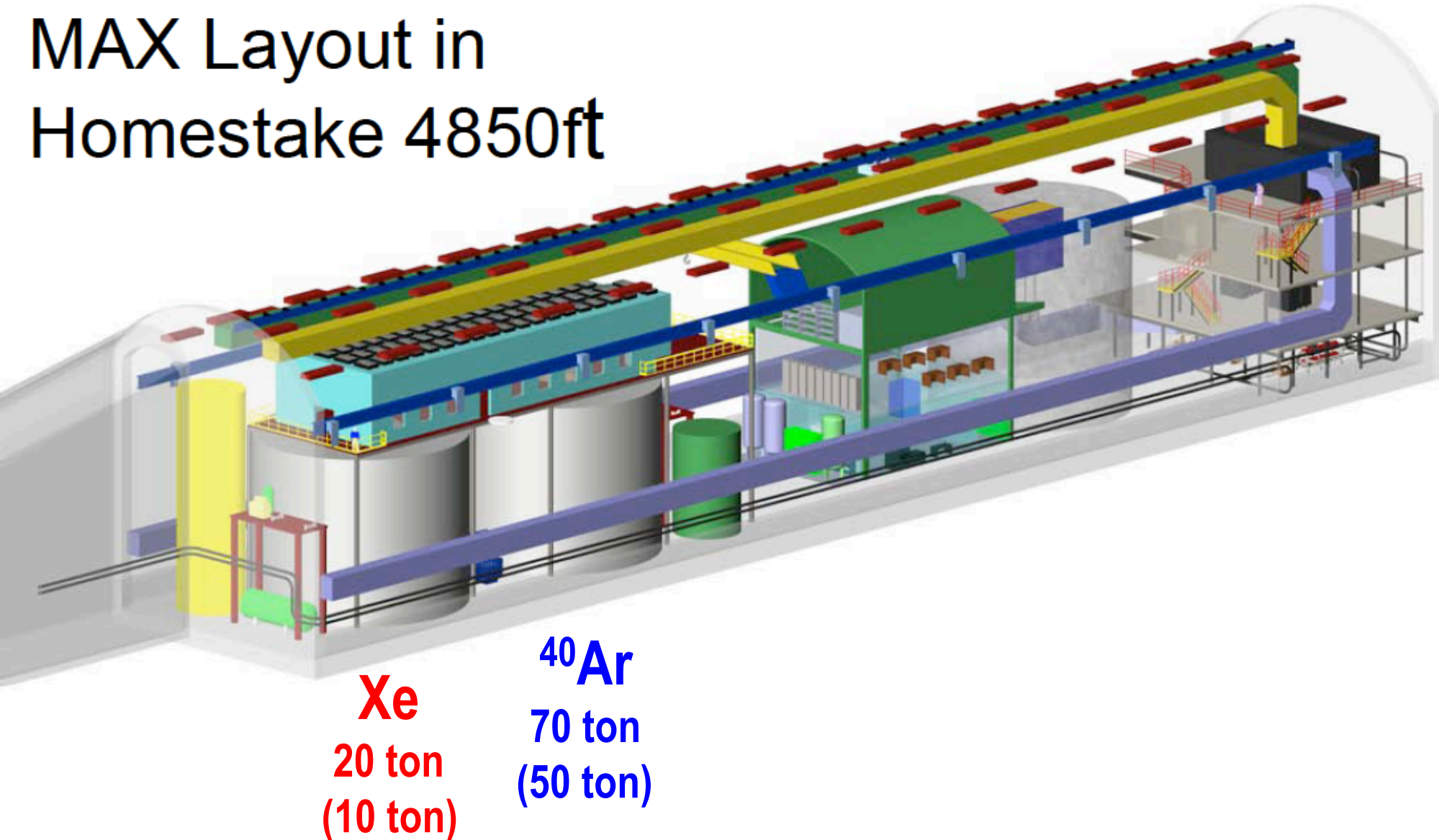

# Schedule at DUSEL

Kevin Lesko

| Year                            | FY11                 | FY12 | FY13        | FY14   | FY15         | FY16         | FY17 | FY18               | FY19                      | FY20 | FY21 | FY22 |
|---------------------------------|----------------------|------|-------------|--------|--------------|--------------|------|--------------------|---------------------------|------|------|------|
| <b>Dark Matter</b>              | Davis Campus         |      |             |        |              |              |      |                    |                           |      |      |      |
| Gen-1                           |                      | LUX  | (Upgrades?) |        |              |              |      |                    |                           |      |      |      |
| Gen-2                           |                      |      |             |        | Generation-2 |              |      |                    |                           |      |      |      |
| R&D Efforts                     |                      |      |             |        |              |              |      | R&D and Prototypes |                           |      |      |      |
|                                 |                      |      |             |        |              | Construction |      |                    | Lab Module 4850L          |      |      |      |
| Gen-3                           |                      |      |             |        |              |              |      | Generation-3       |                           |      |      |      |
| <b>0νββ</b>                     |                      |      |             |        |              |              |      |                    |                           |      |      |      |
| MJD Electroforming              | Temporary Clean Room |      |             |        |              |              |      |                    |                           |      |      |      |
| Majorana Demonstrator           | Davis Campus         |      |             |        |              |              |      |                    |                           |      |      |      |
| <b>LBNE (possible timeline)</b> |                      |      |             |        |              |              |      |                    |                           |      |      |      |
| CD - Approvals                  |                      |      | CD1         | CD2/3a | CD3          | Construction |      |                    | Outfitting,<br>Liner, etc |      |      | LBNE |

# US Dark Matter Programs

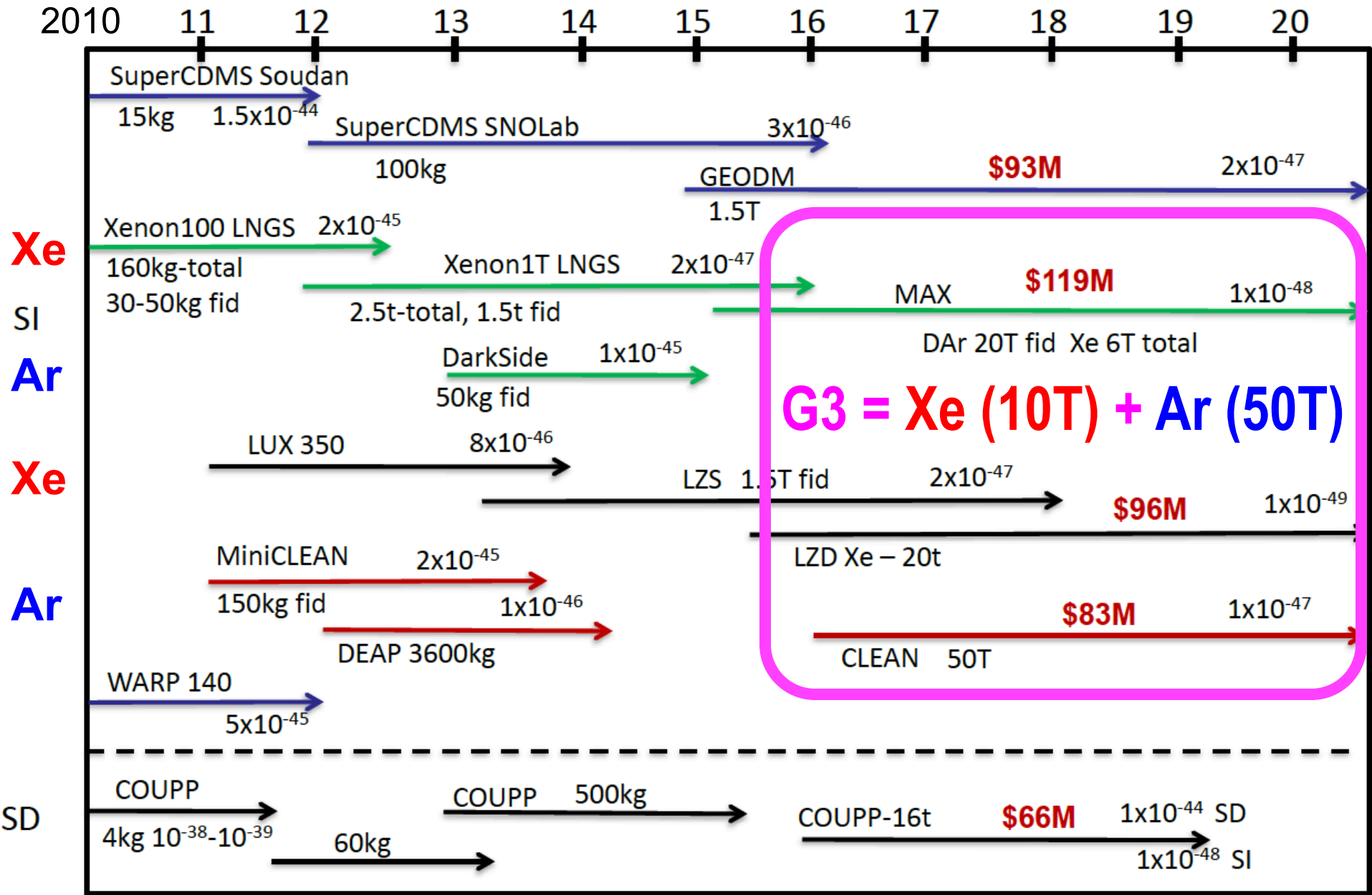

# Conclusions

## ➤ MAX

- **10 Ton Xe + 50 Ton Ar** at DUSEL
- Joint efforts by **XENON** and **DarkSide** collaborations (currently at LNGS towards G2)

## ➤ Science cases

- Sensitivity down to  **$10^{-48} \text{ cm}^2$**
- Precision measurements if  **$> 10^{-46} \text{ cm}^2$**
- Possibility to combine with **0 $\nu$  Double Beta Decays** → **XAX**