

# MAX & XAX

Dark Matter and Neutrino Observatory  
based on multi-ton  
Liquid Xenon and Liquid Argon

**Katsushi Arisaka**

*University of California, Los Angeles  
Department of Physics and Astronomy*

arisaka@physics.ucla.edu

# MAX - Multi-ton Argon & Xenon

MAX Collaboration = DarkSide + XENON

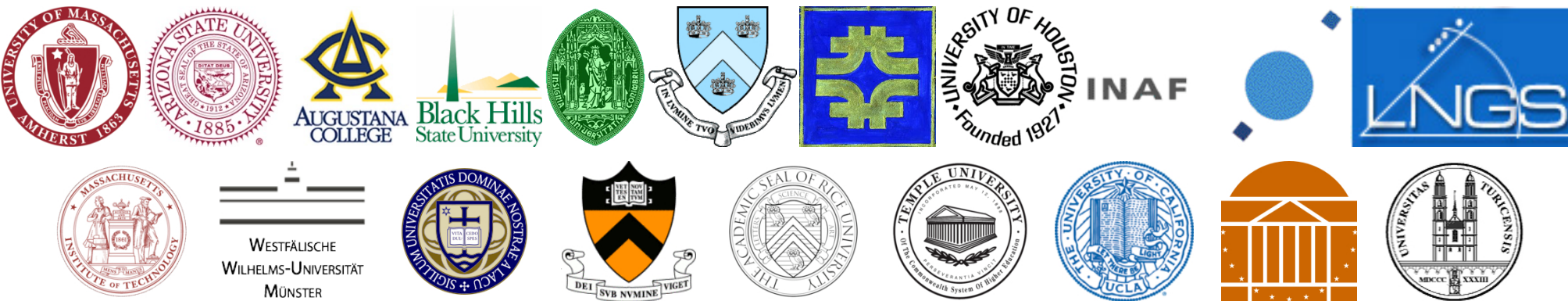

UMass Amherst, Arizona State University,  
Augustana College, Black Hills State University,  
Coimbra University, Columbia University, Fermilab,  
University of Houston, INAF, LNG, MIT, University of Münster,  
University of Notre Dame, Princeton University, Rice University,  
Temple University, UCLA, University of Virginia,  
University of Zürich

# Roadmap to MAX

2012 2013 2014 2015 2016 2017 2018 2019 2020

Gran Sasso → DUSEL

MAX

XENON100

XENON 1T

Xe 10T

Ar 50T

DarkSide50

DarkSide 5T

G1

G2

G3

(Antonio Melgarejo)

(Ran Budnik)

(Richard Saldanha)

# XENON 1T (G2) at Gran Sasso

*Ran Budnik's talk*

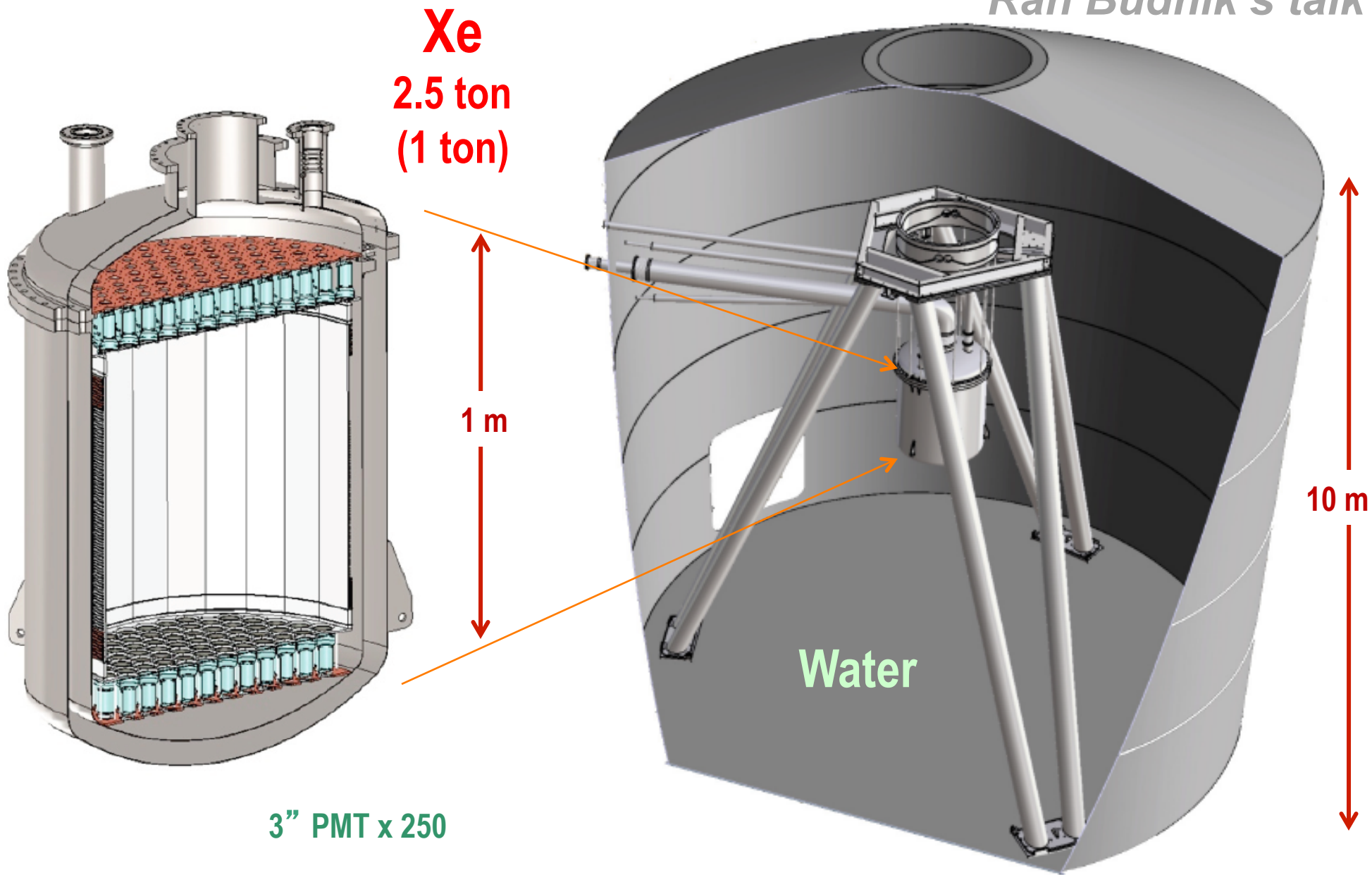

# DarkSide 5T (G2) at Gran Sasso

*Richard Saldanha's talk*

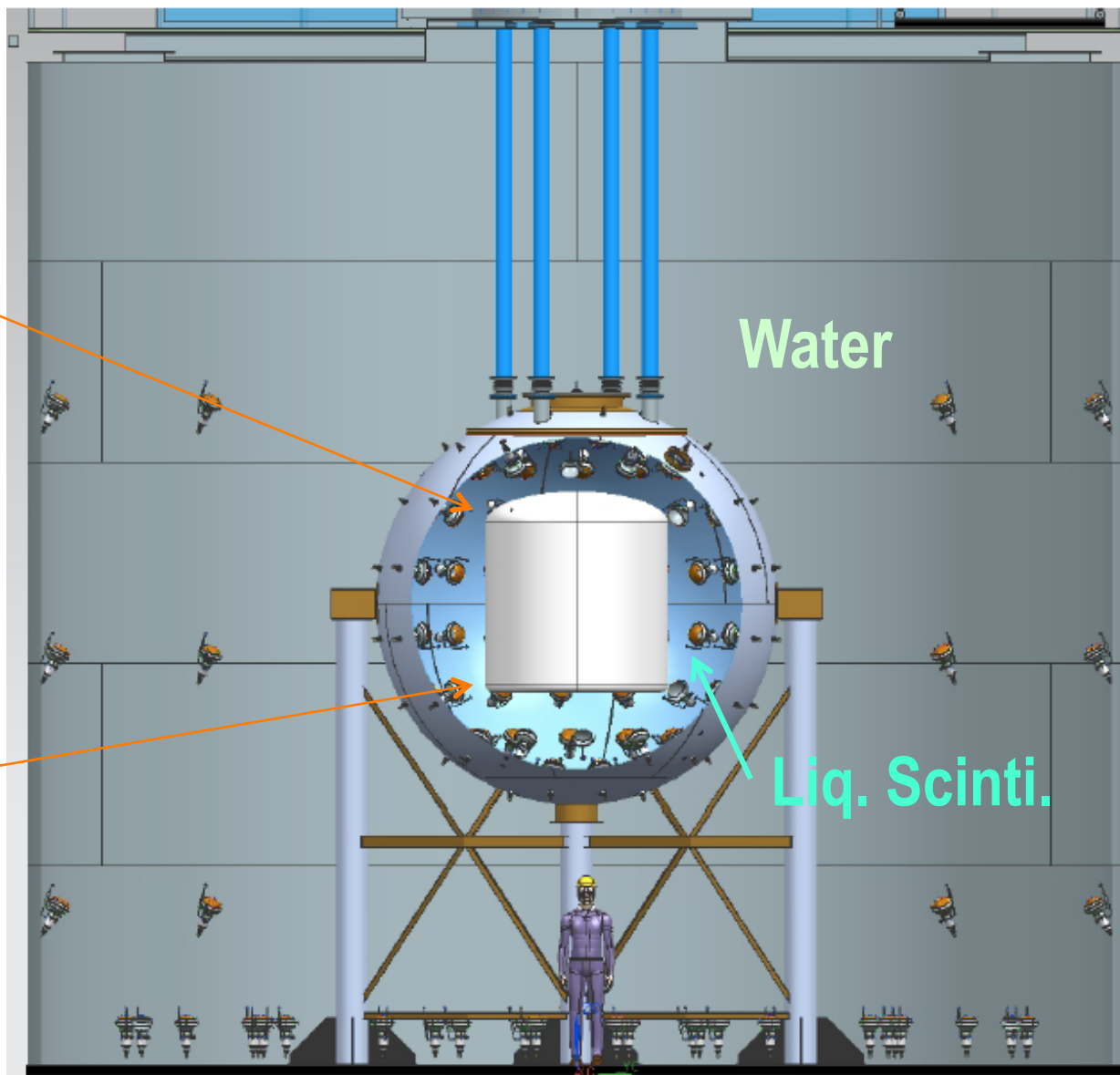
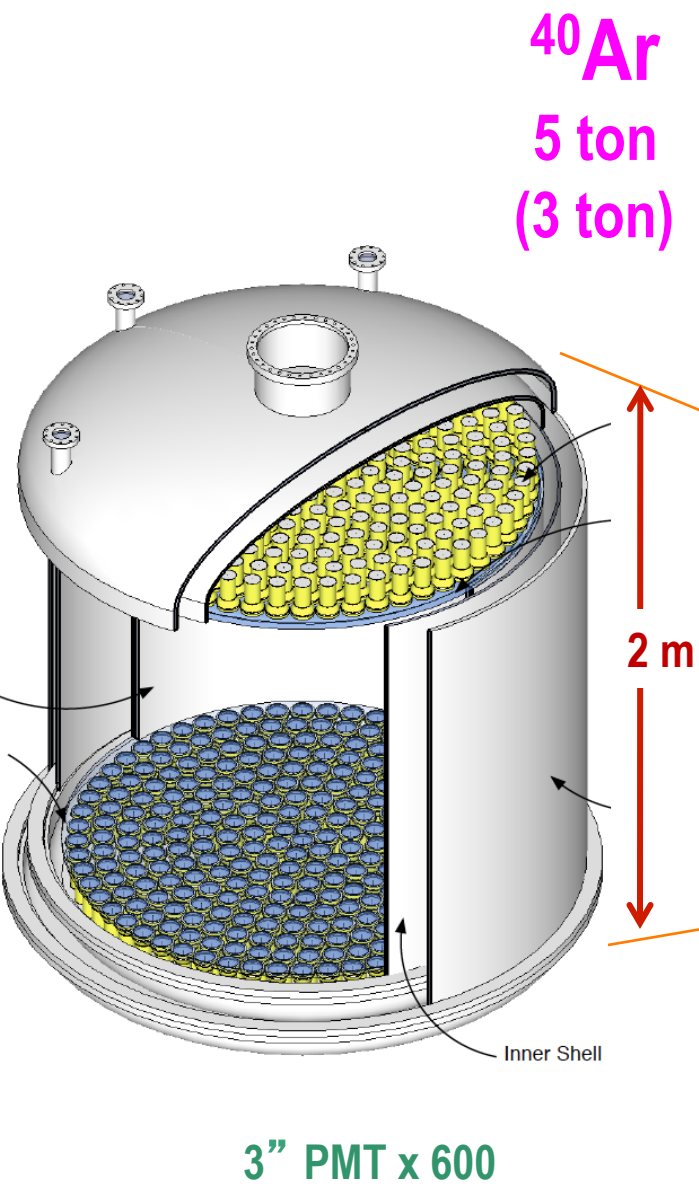

# MAX G3 Detector

Xe 20 ton (10 ton)

$^{40}\text{Ar}$  70 ton (50 ton)

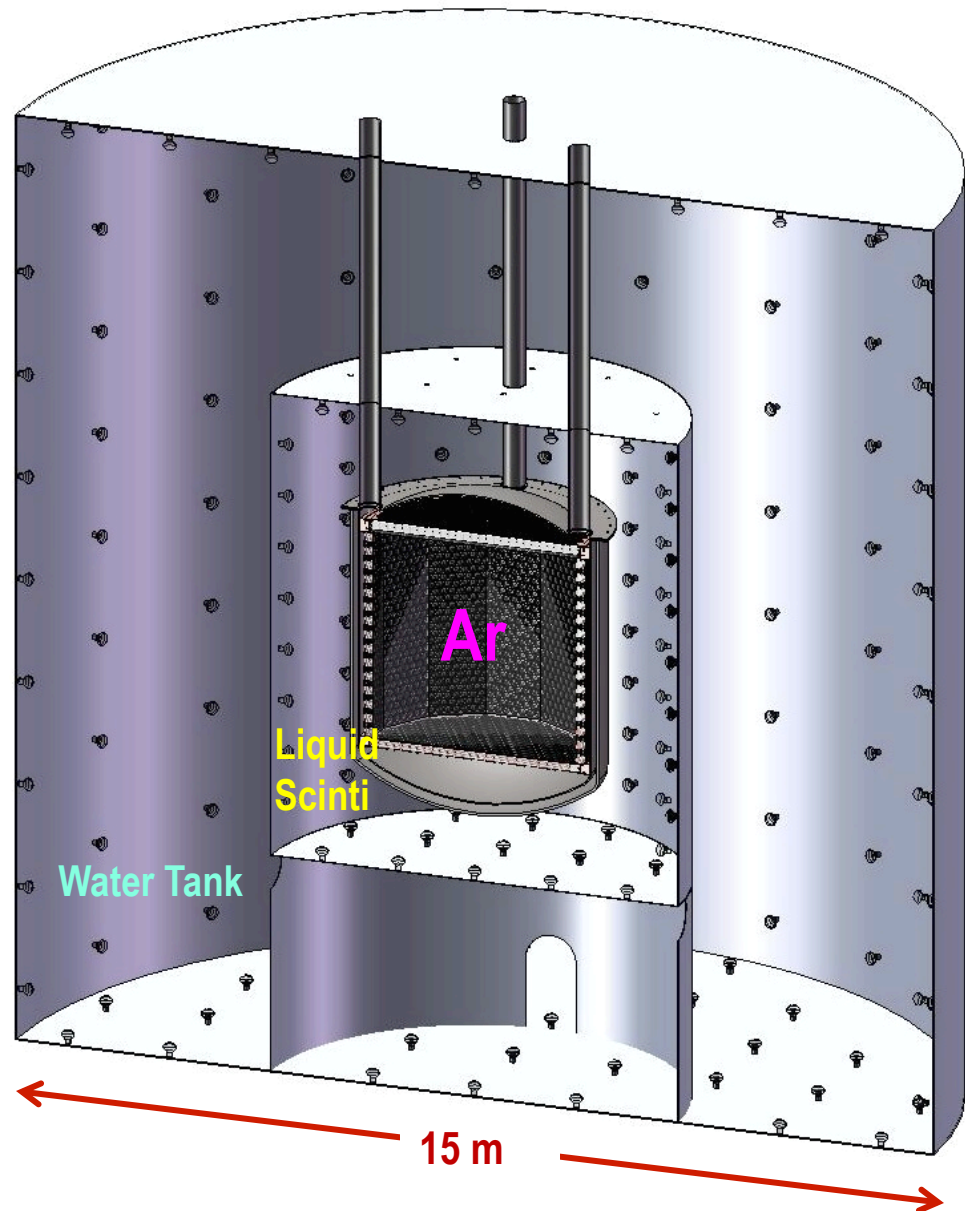
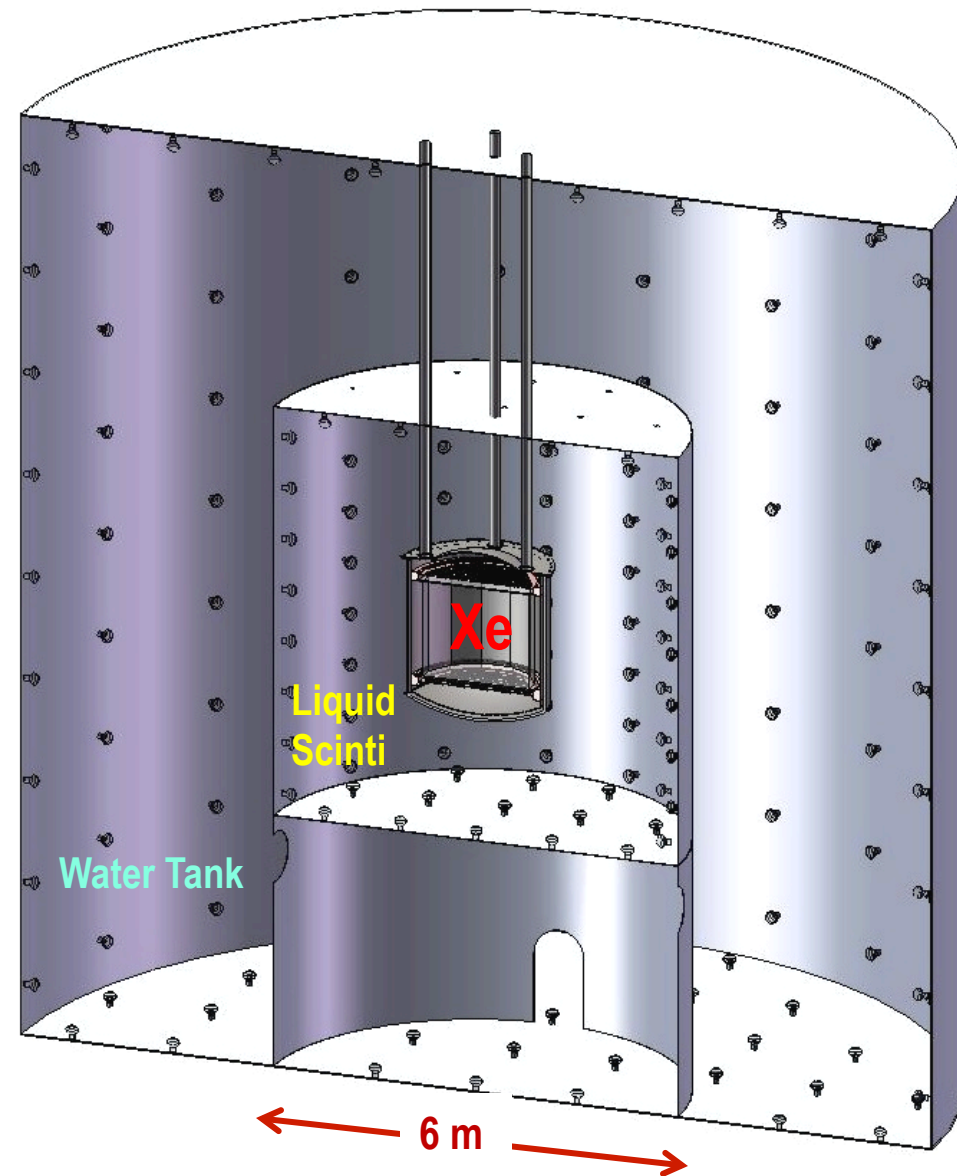

# MAX G3 Detector

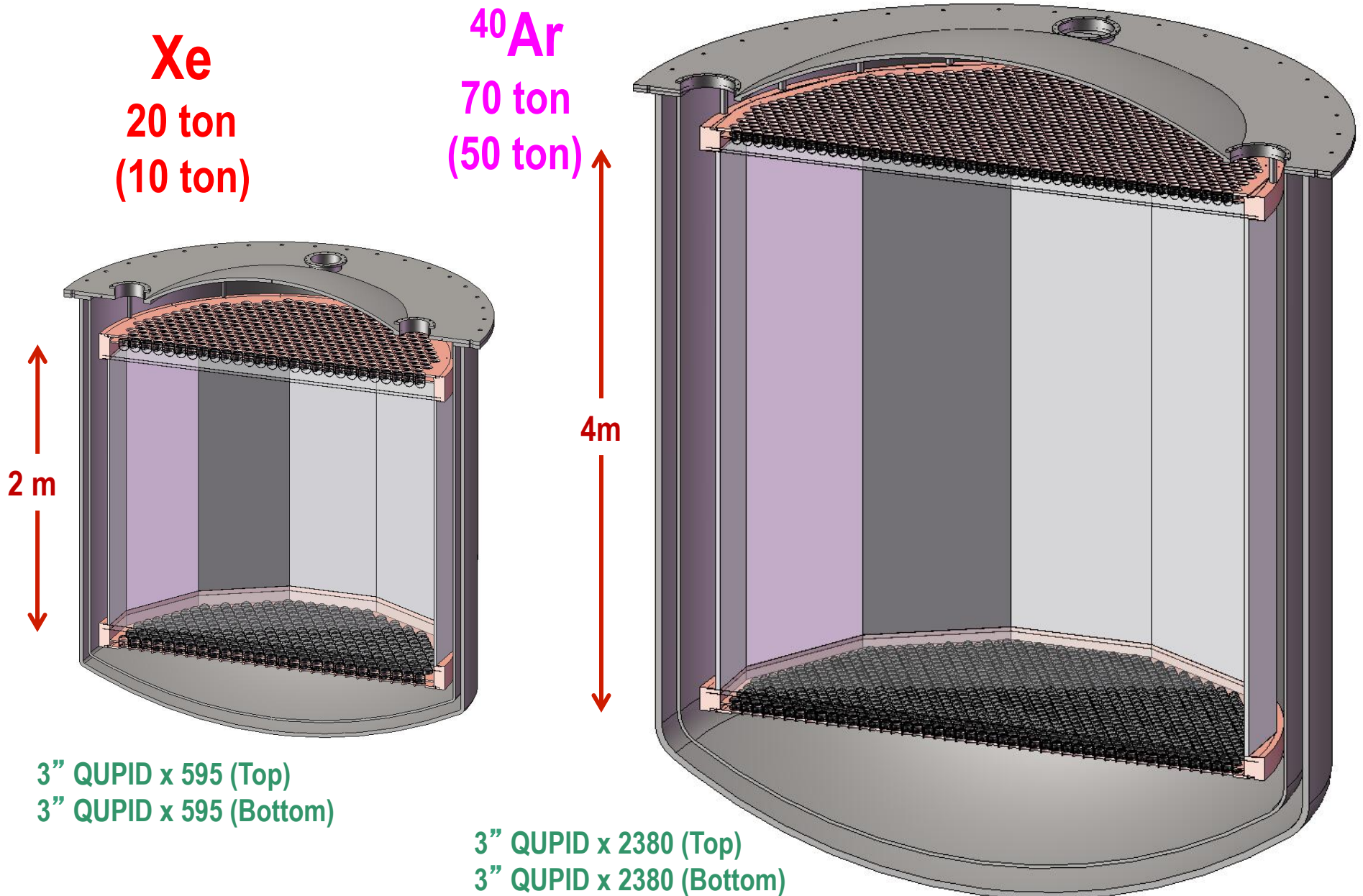

# MAX G3 Detector (4π coverage)

**Xe**

**20 ton  
(10 ton)**

**$^{40}\text{Ar}$**

**70 ton  
(50 ton)**

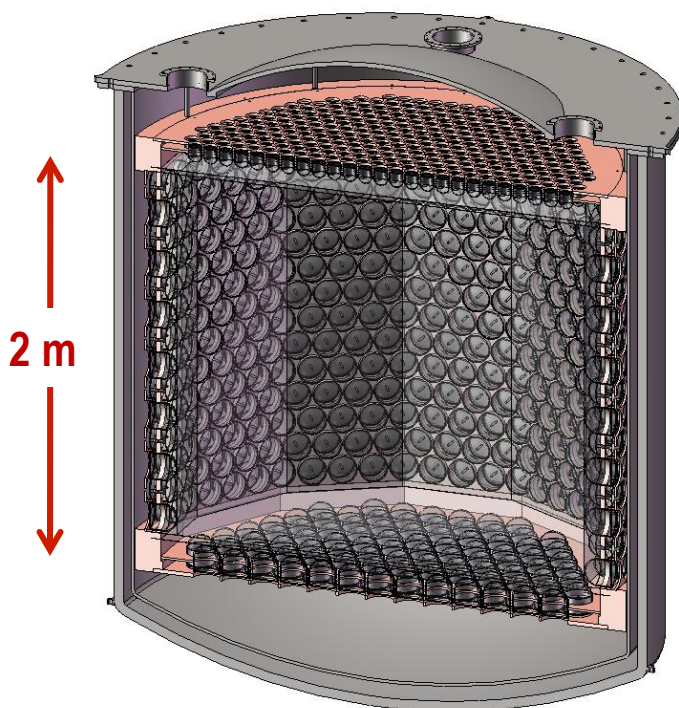

**3" QUPID x 595 (Top)**  
**6" QUPID x 825 (Side/Bottom)**

**4m**

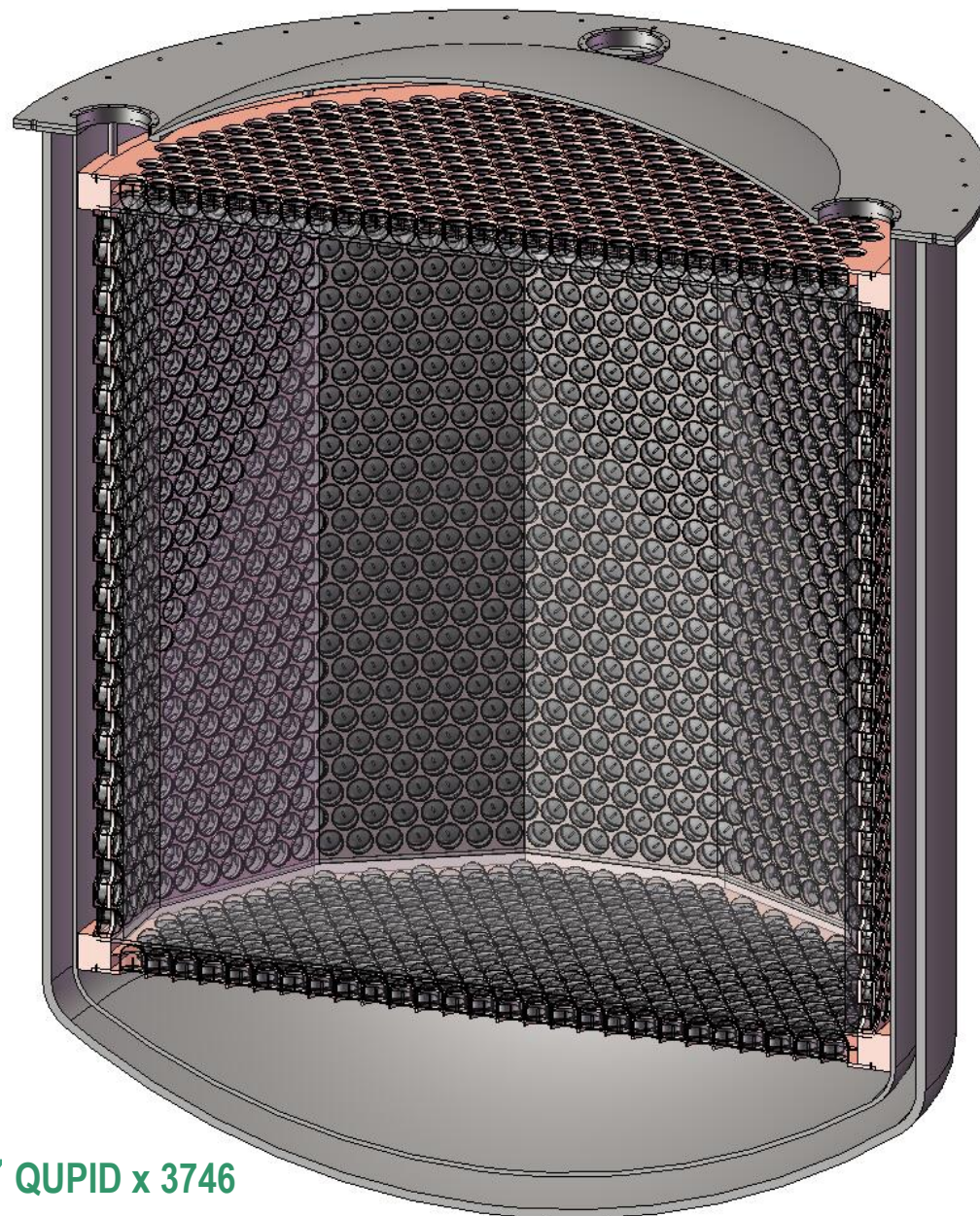

**6" QUPID x 3746**

# MAX G3 Detector (at DUSEL)

MAX Layout in  
Homestake 4850ft

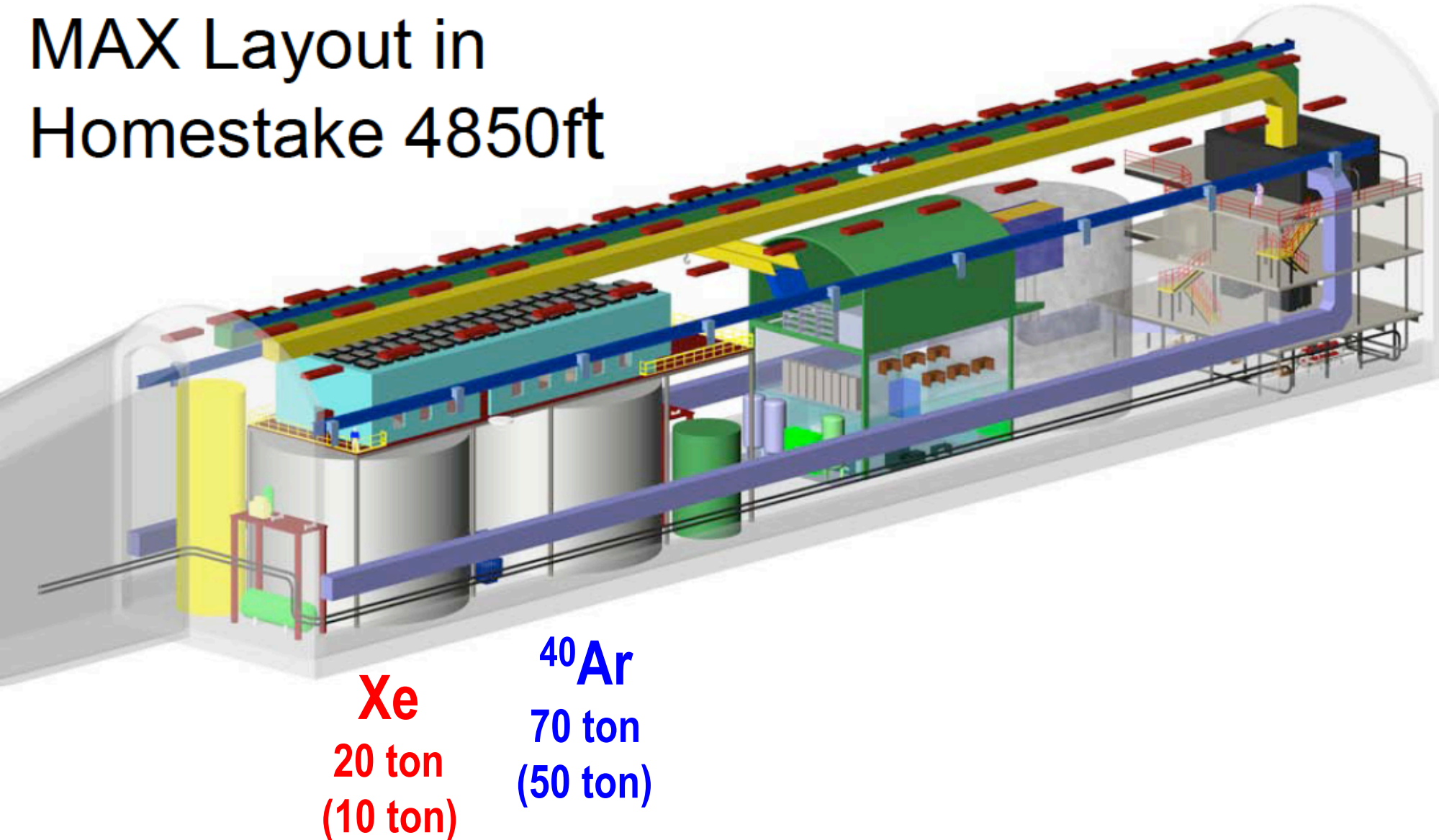

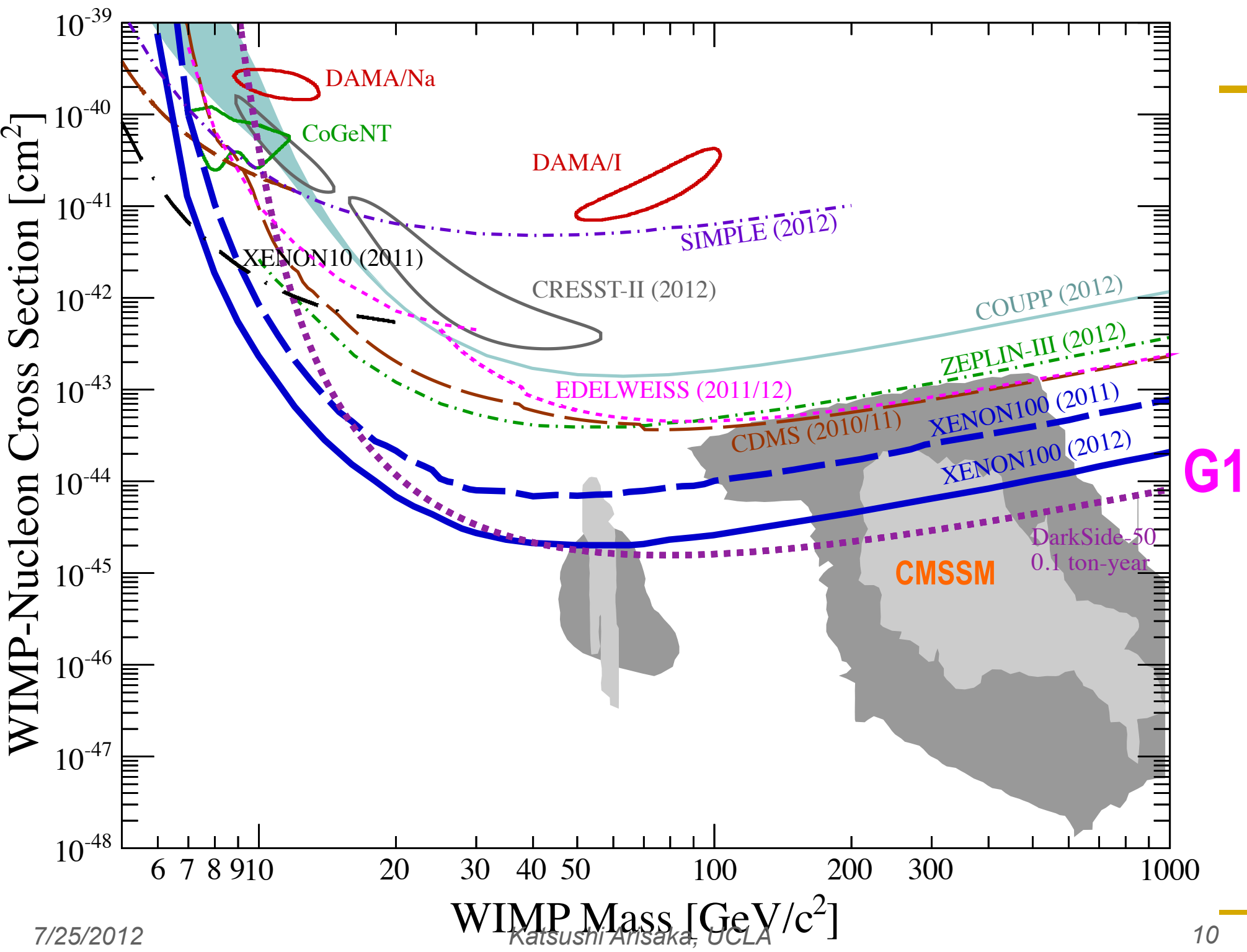

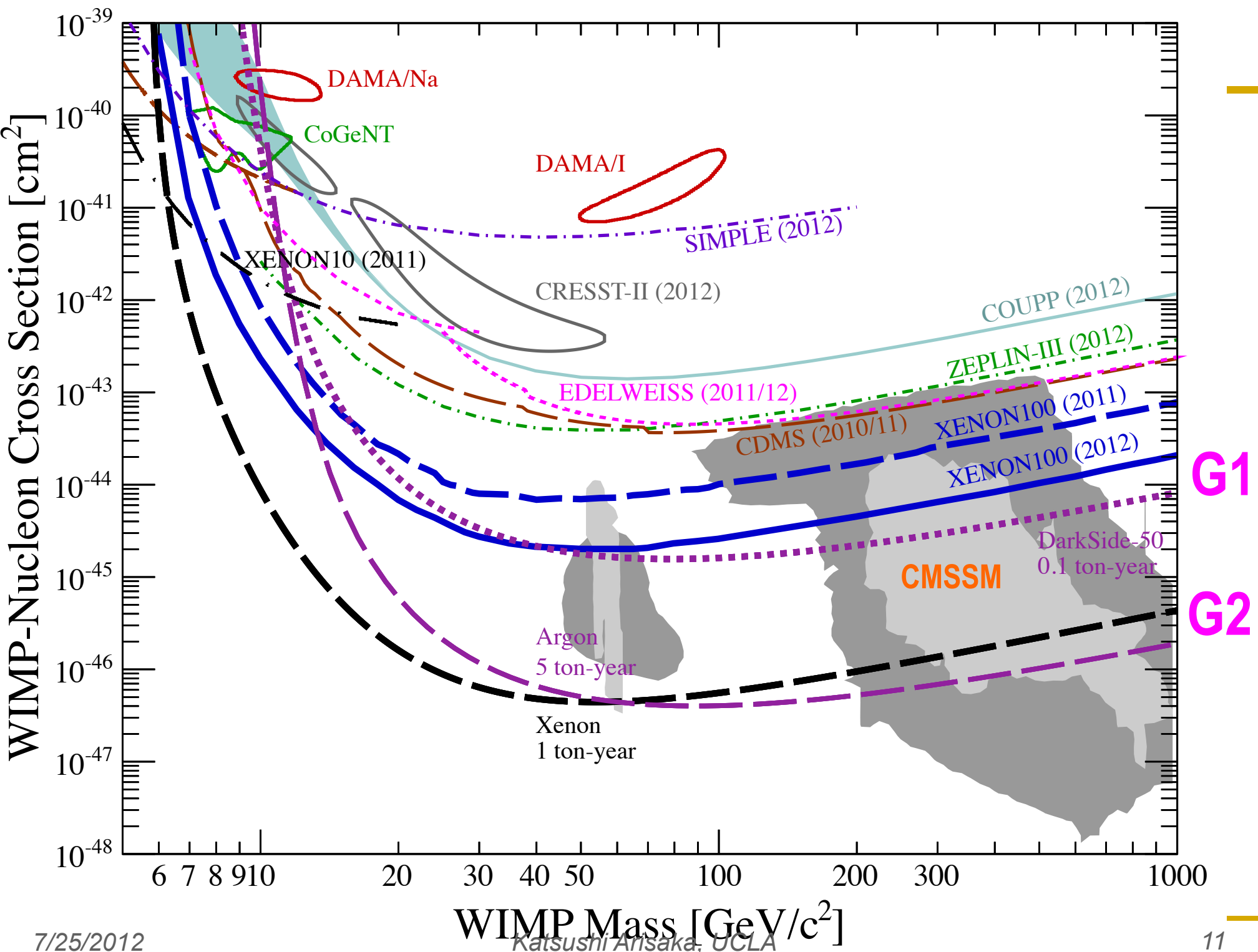

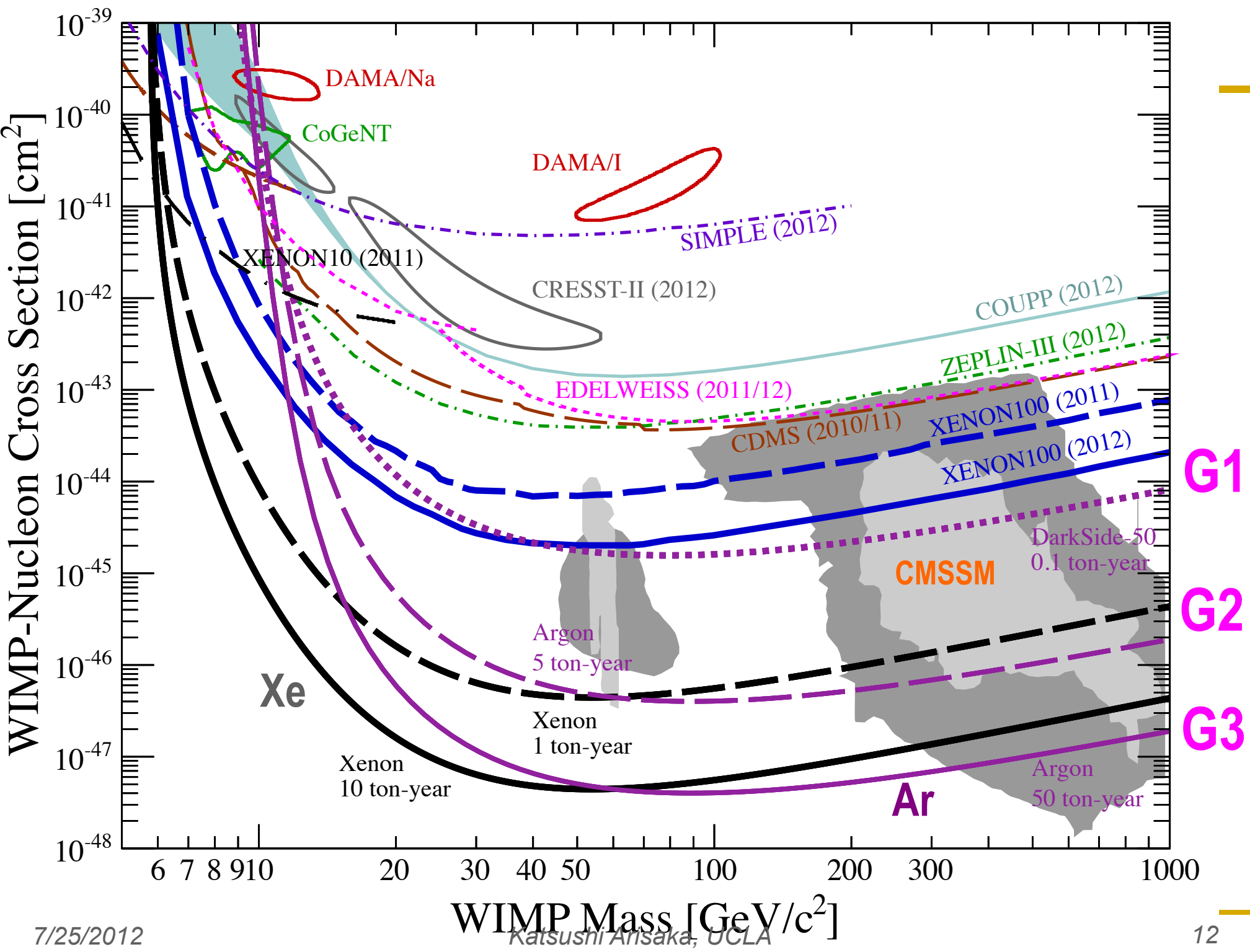

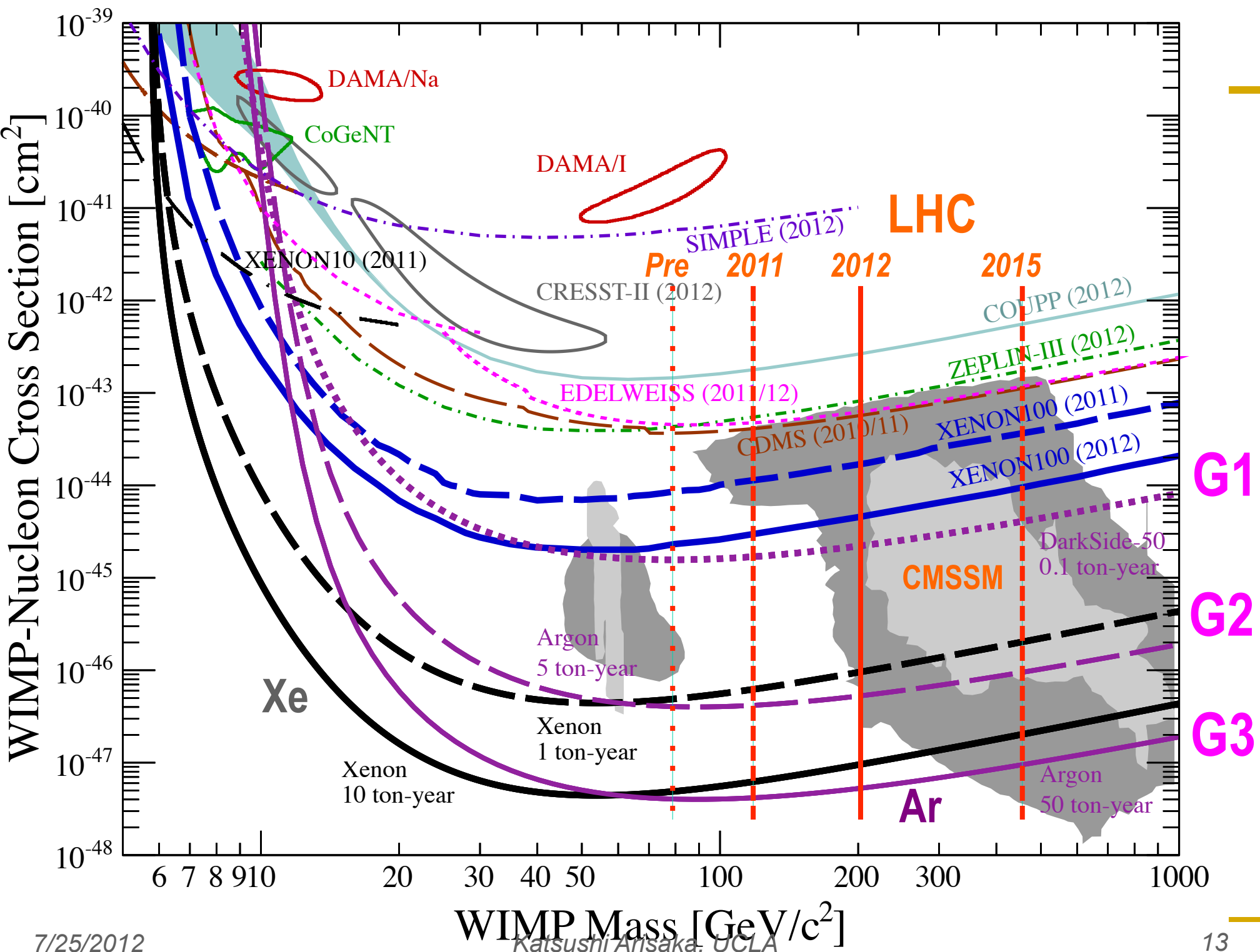

# (SI) WIMP Energy Spectrum for LXe (Cross Section = $10^{-45} \text{cm}^2$ )

(SI) WIMP Recoil Energy Spectrum for LXe ( $\sigma = 10^{-45} \text{cm}^2$ )

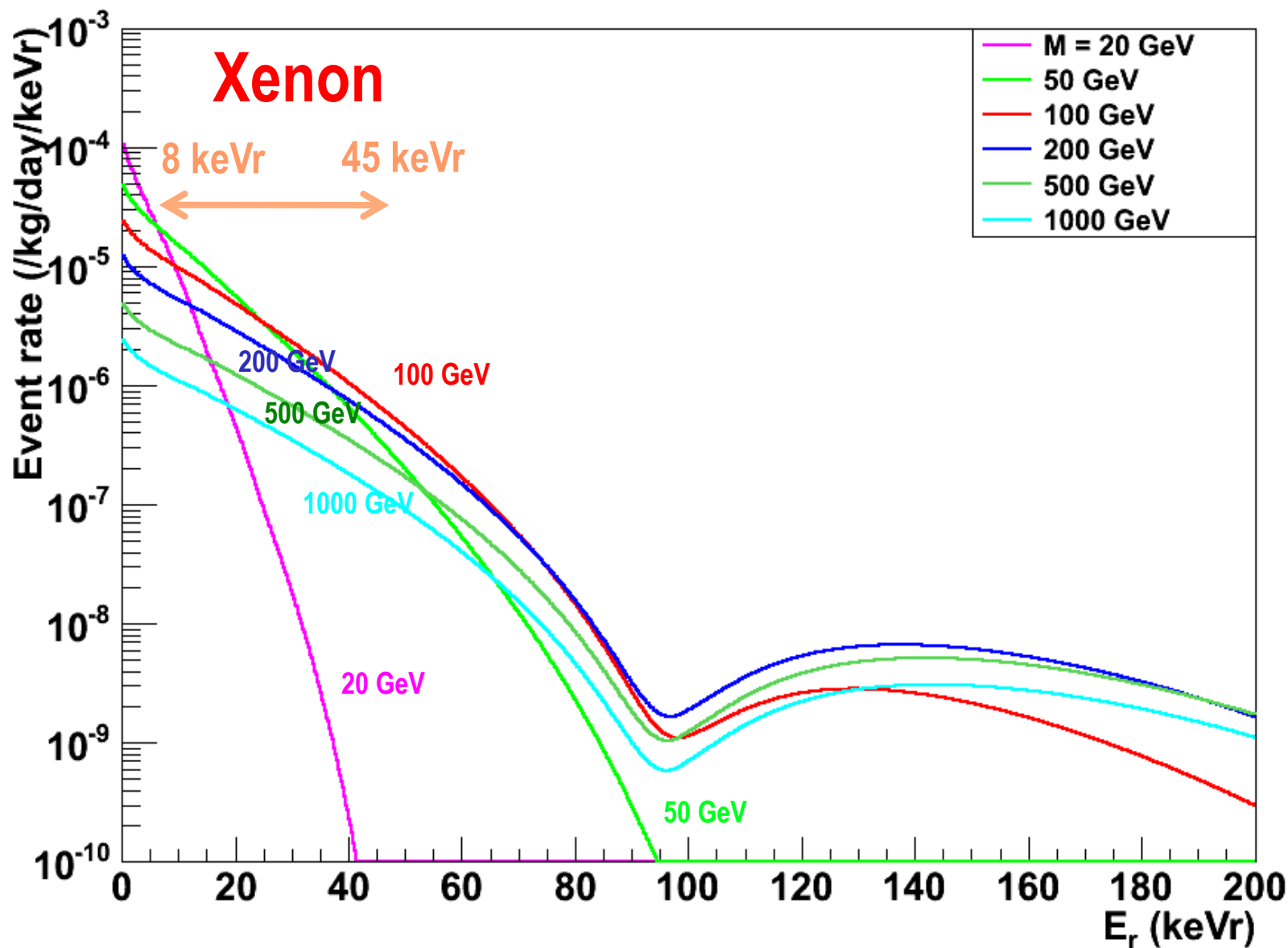

# (SI) WIMP Energy Spectrum for LAr (Cross Section = $10^{-45}\text{cm}^2$ )

(SI) WIMP Recoil Energy Spectrum for LAr ( $\sigma = 10^{-45}\text{cm}^2$ )

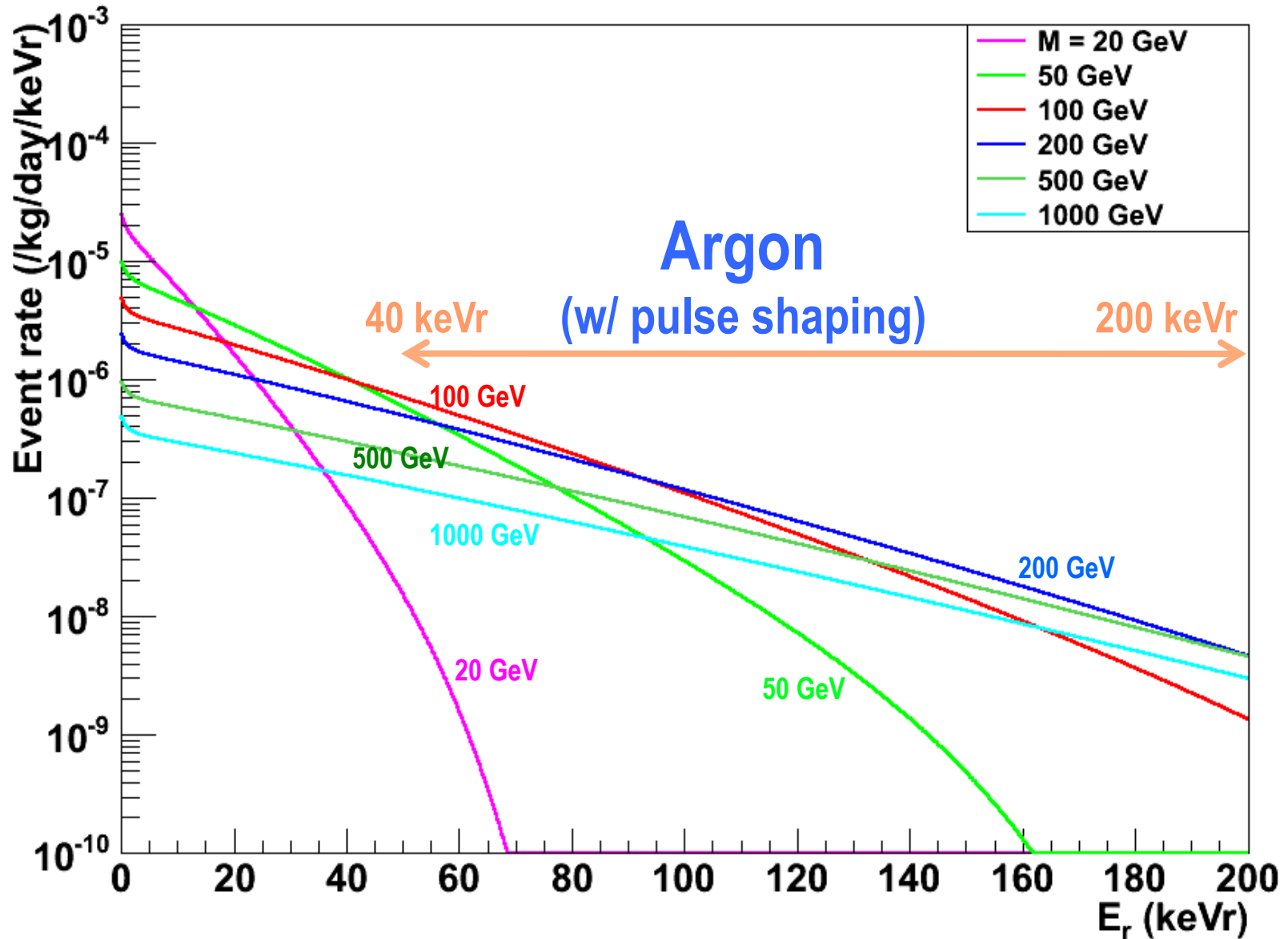

# 1- $\sigma$ Error of WIMP Mass vs SI Cross Section (10 ton\*year Xe and 50 ton\*year Ar)

1- $\sigma$  Error of WIMP Mass and SI Cross Section

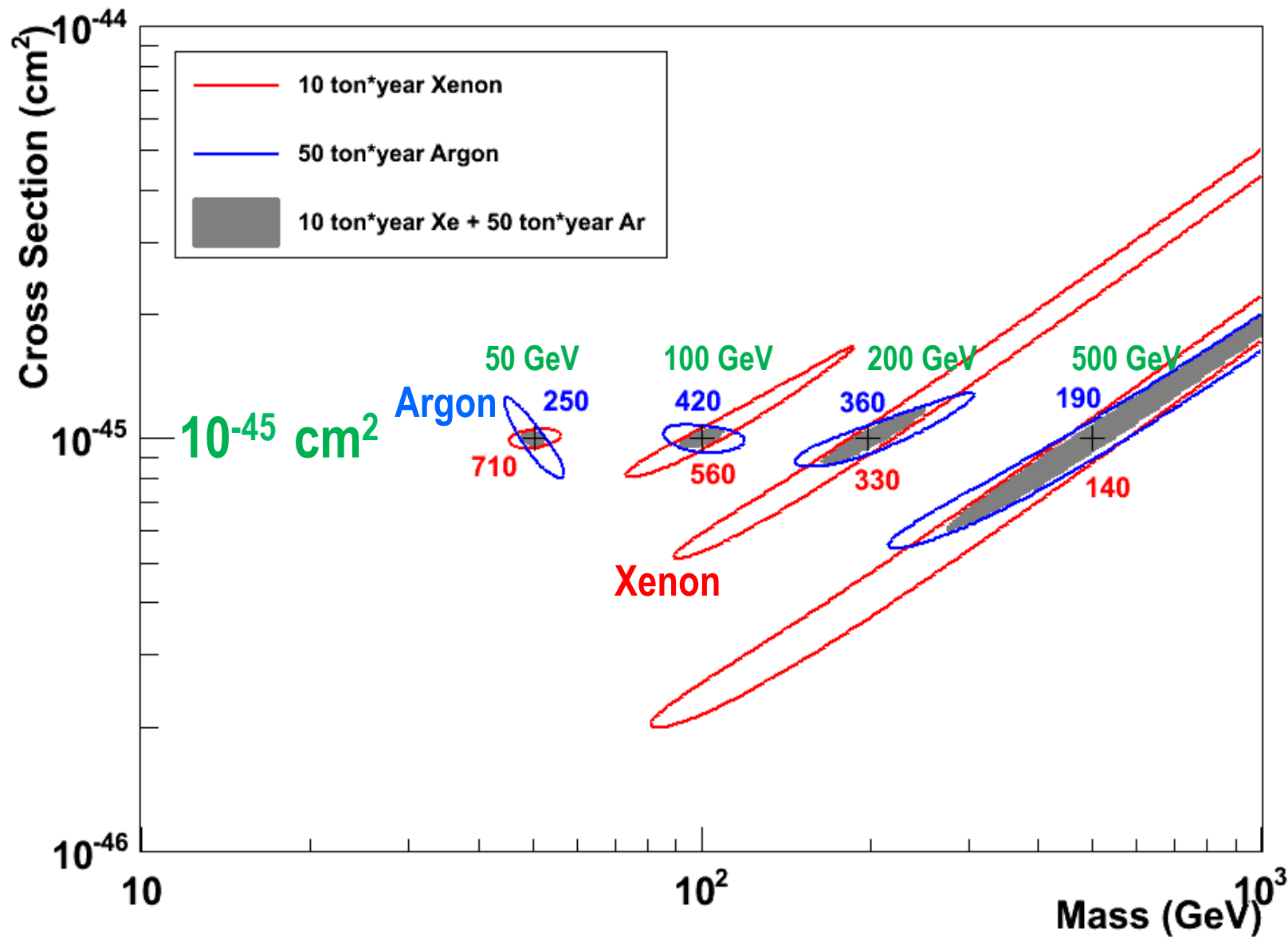

# 1- $\sigma$ Error of WIMP Mass vs SI Cross Section (10 ton\*year Xe and 50 ton\*year Ar)

1- $\sigma$  Error of WIMP Mass and SI Cross Section

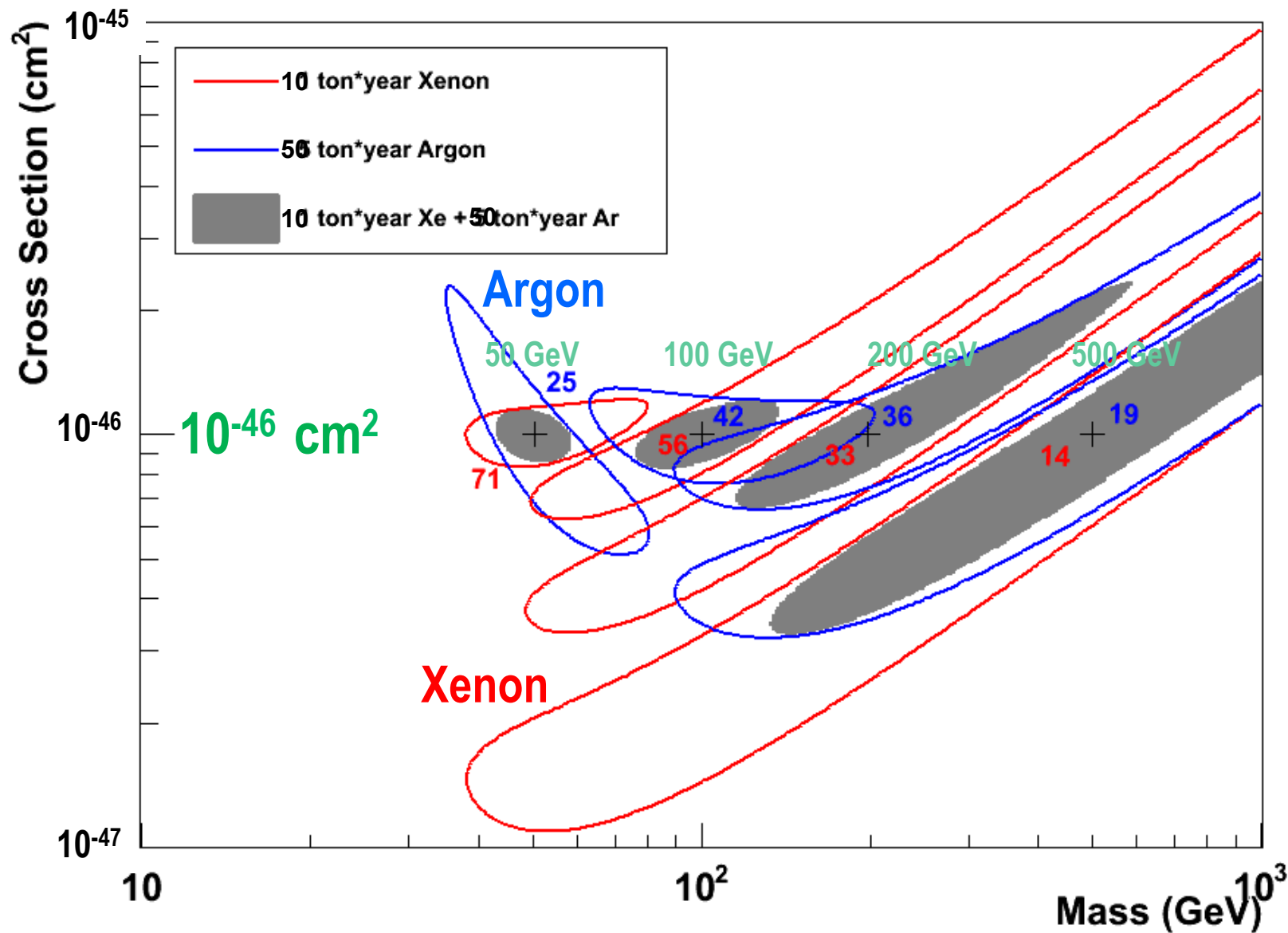

# 1- $\sigma$ Error of WIMP Mass vs SI Cross Section (10 ton\*year Xe and 50 ton\*year Ar)

1- $\sigma$  Error of WIMP Mass and SI Cross Section

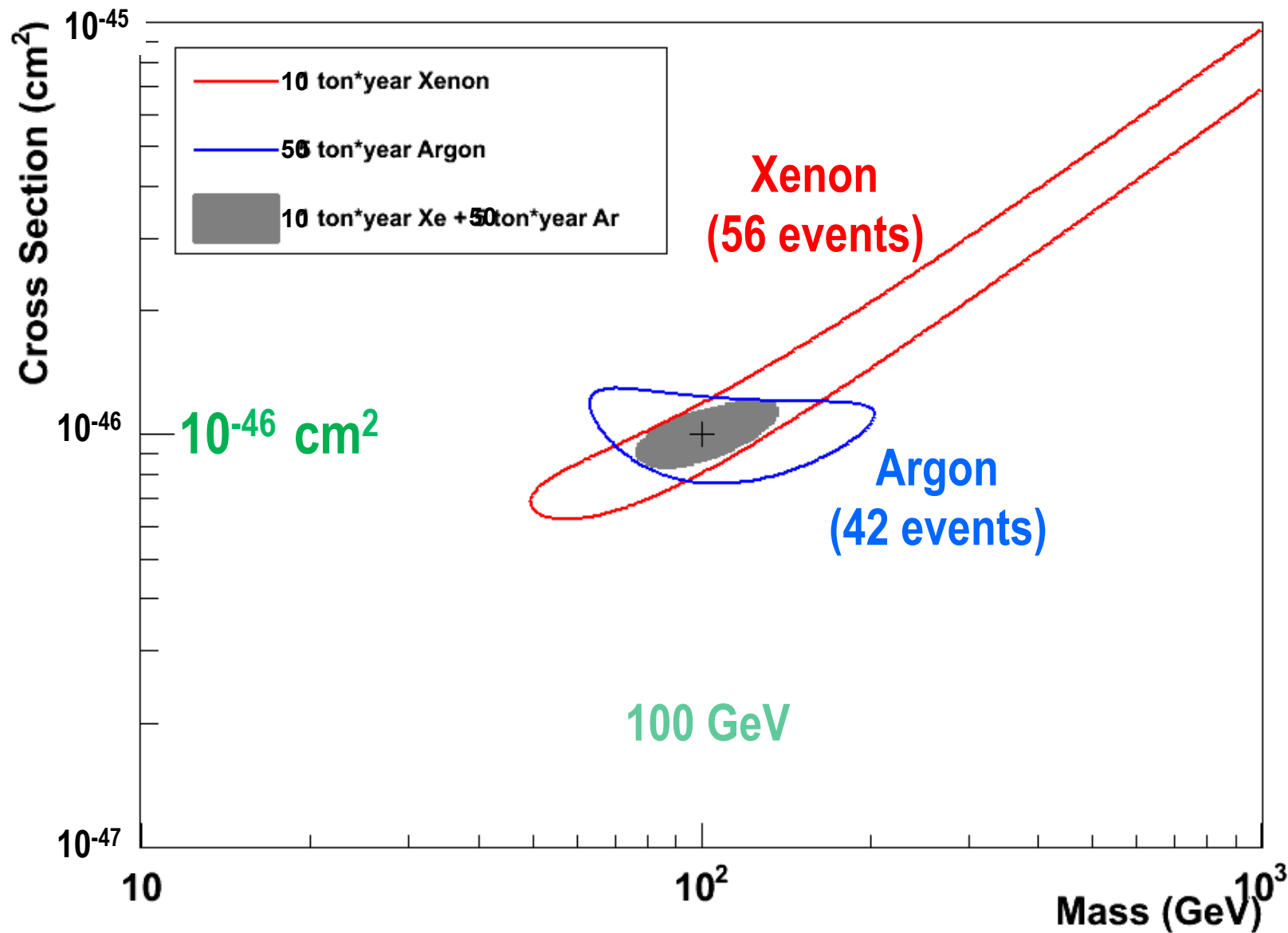

# 1- $\sigma$ Error of WIMP Mass vs SI Cross Section (10 ton\*year Xe and 50 ton\*year Ar)

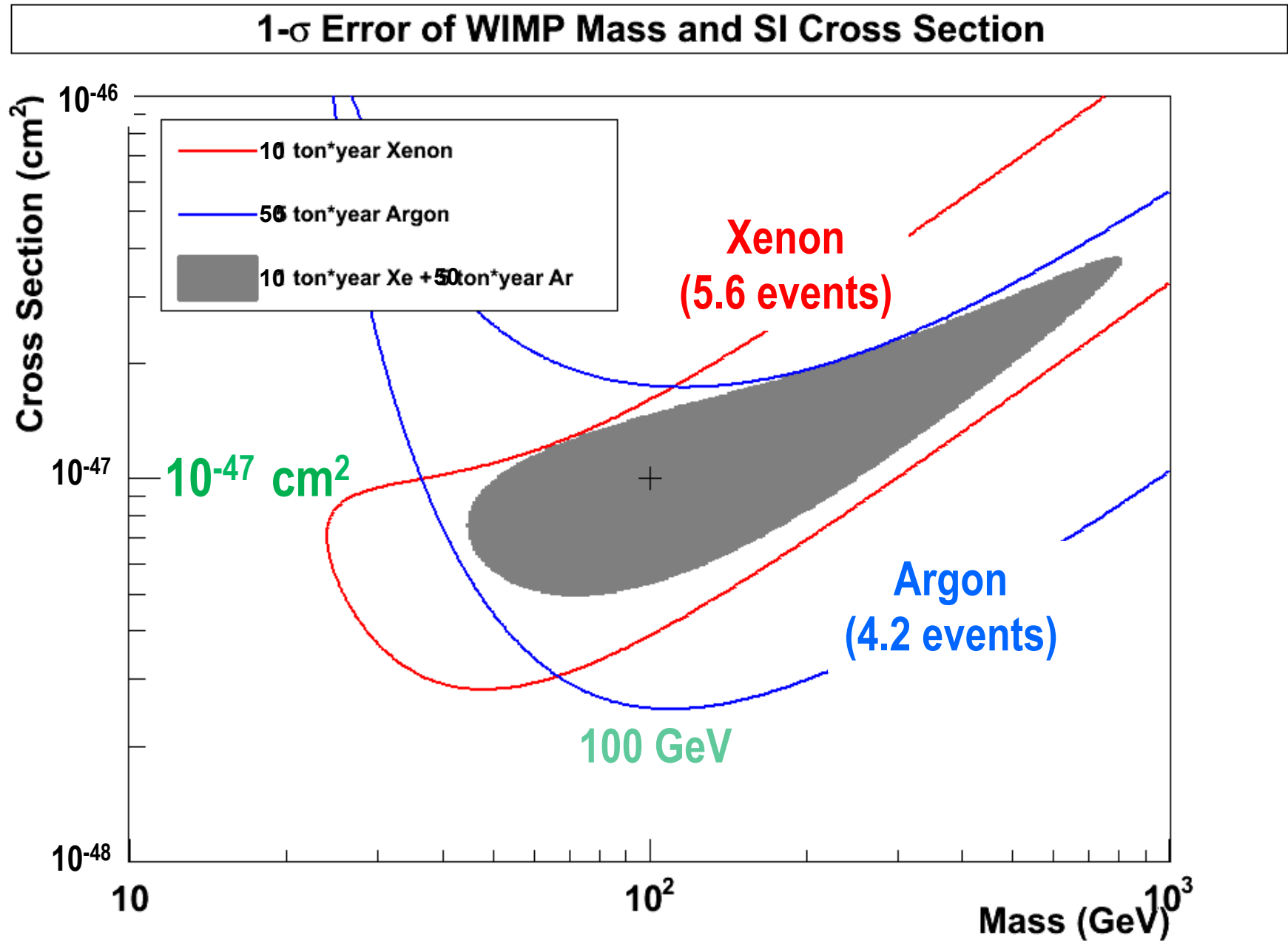

# (SI) WIMP Energy Spectrum for LXe (Cross Section = $10^{-45} \text{cm}^2$ )

(SI) WIMP Recoil Energy Spectrum for LXe ( $\sigma = 10^{-45} \text{cm}^2$ )

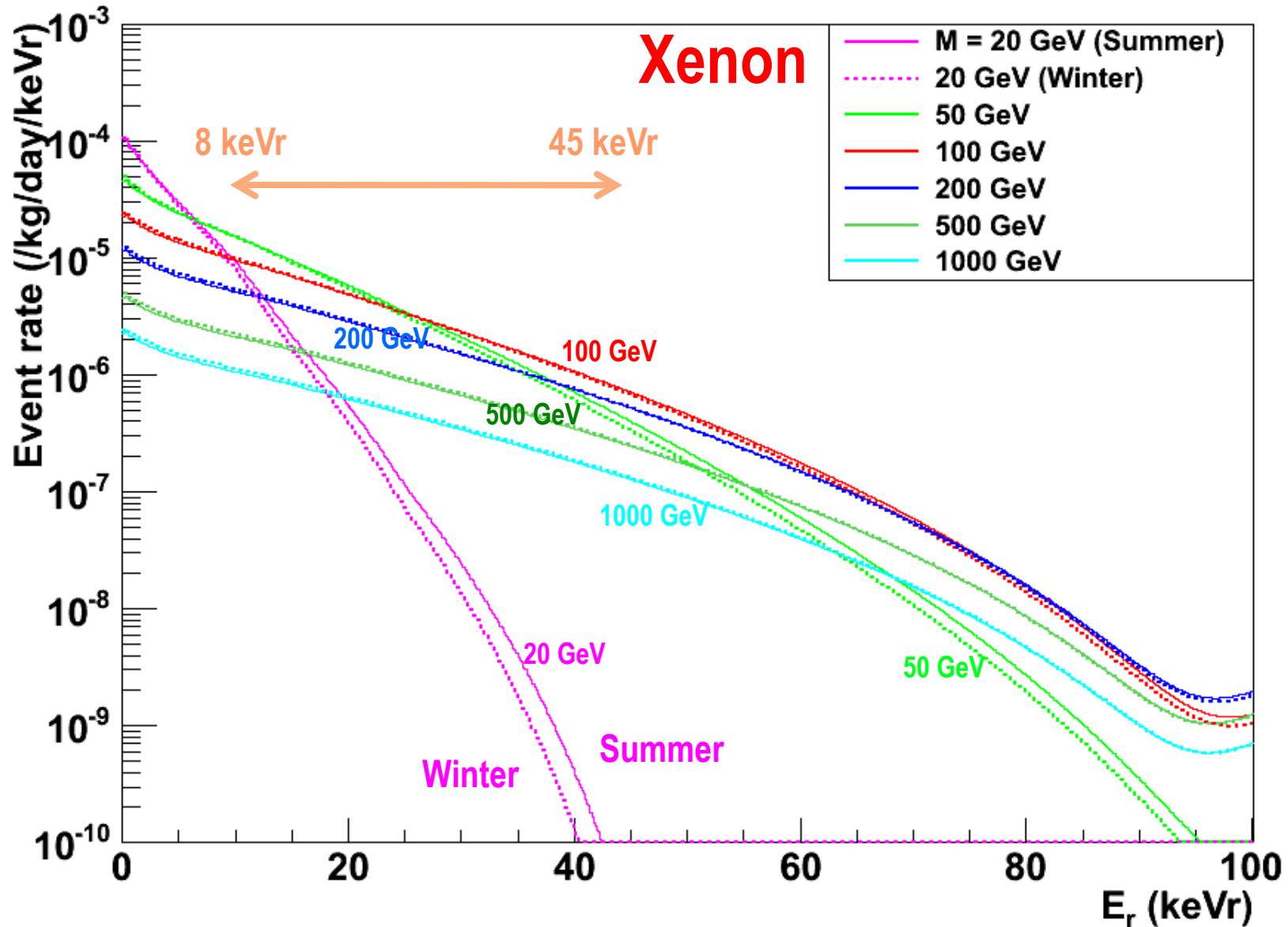

# (SI) WIMP Energy Spectrum for LAr (Cross Section = $10^{-45} \text{cm}^2$ )

(SI) WIMP Recoil Energy Spectrum for LAr ( $\sigma = 10^{-45} \text{cm}^2$ )

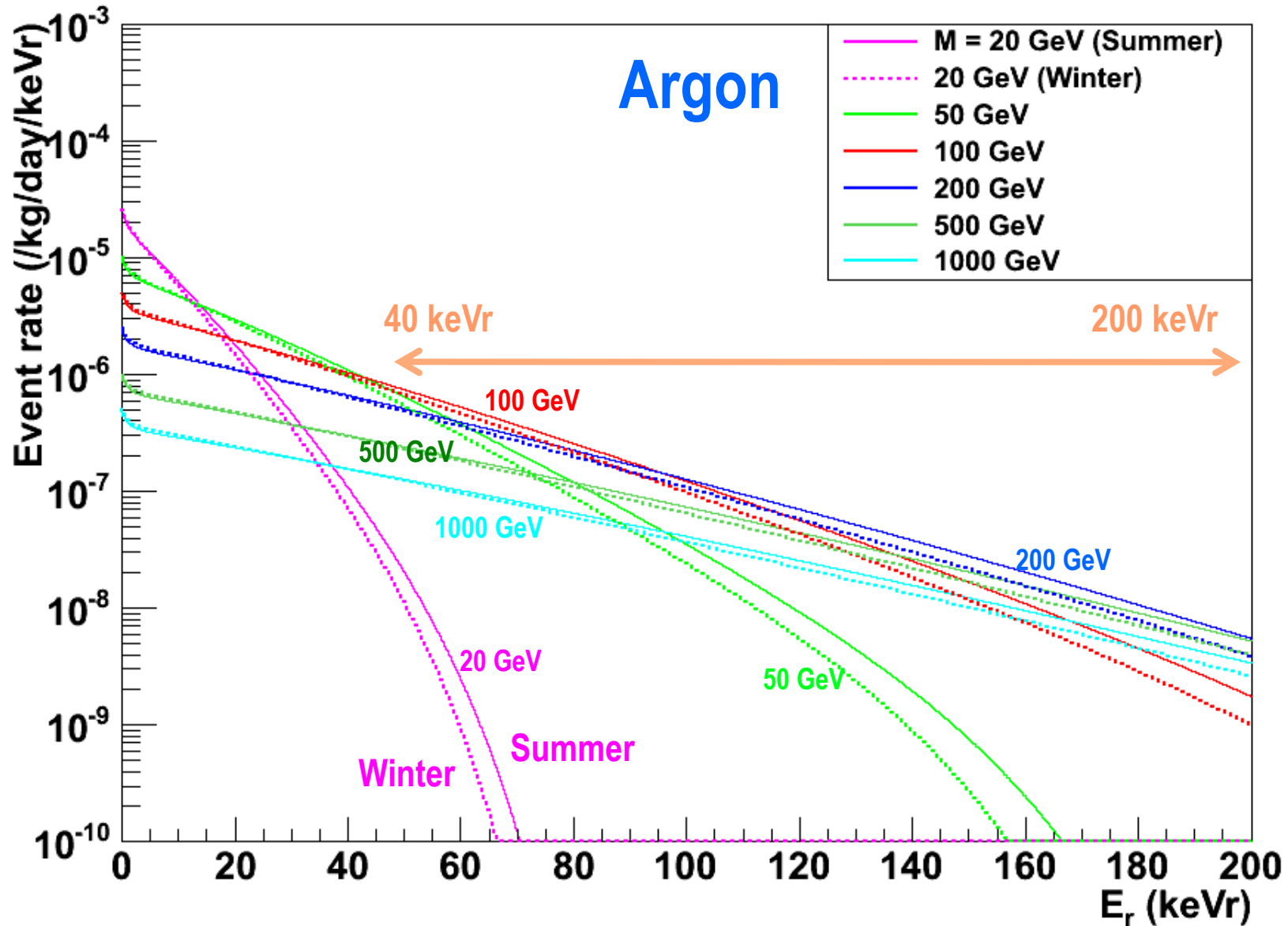

# $\pm 1\sigma$ Error of Annual Modulation Amplitude vs WIMP Mass (10 ton\*year Xe and 50 ton\*year Ar, Cross Section = $10^{-45}\text{cm}^2$ )

1-Sigma Error of Annual Modulation Amplitude vs WIMP Mass ( $\sigma = 1\text{E-}45\text{cm}^2$ )

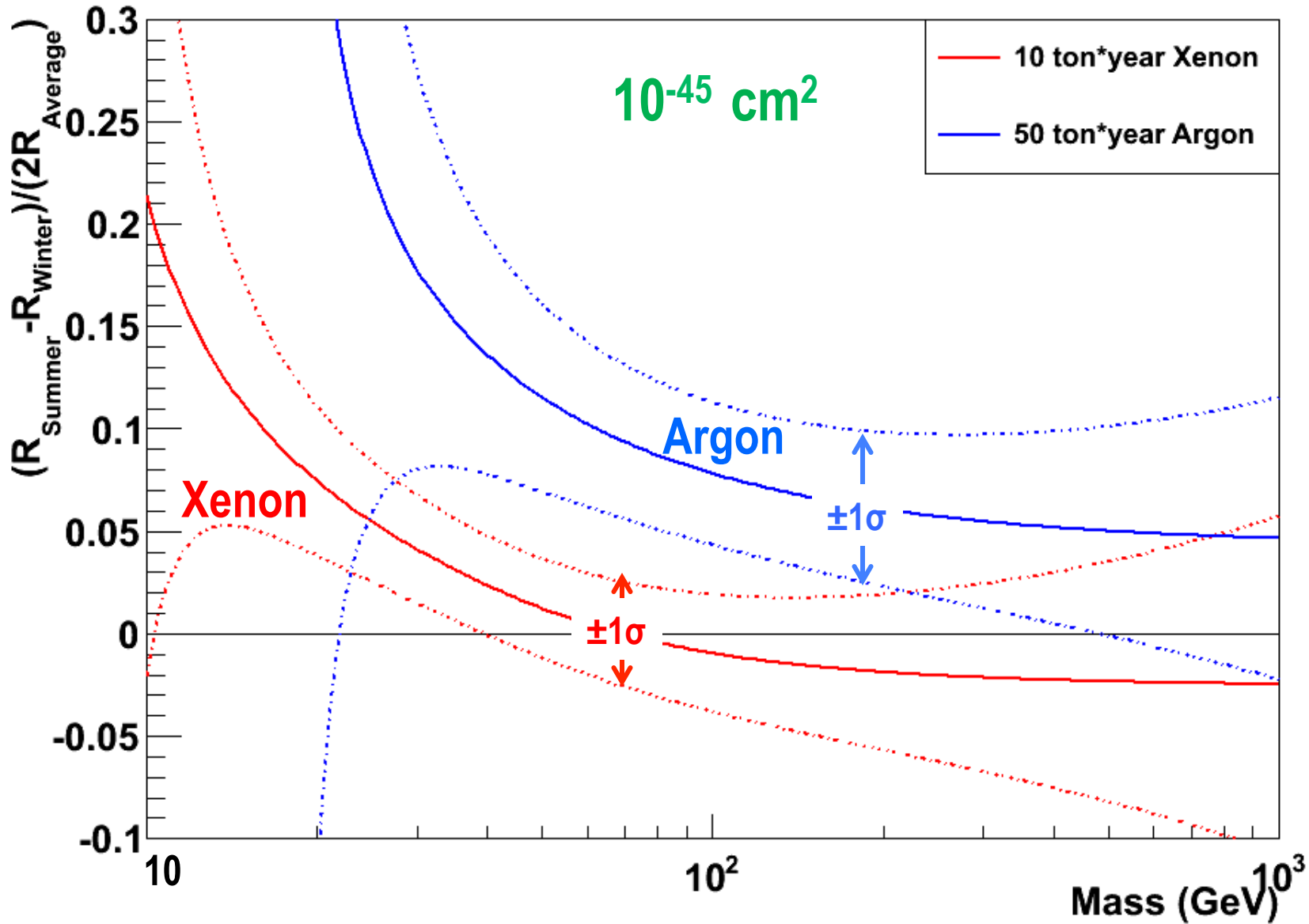

# Technological Challenges

## ➤ External Backgrounds

- Deep underground
- > 5 m water shielding

- DUSEL 4850 ft
- Water Tank (15 m)

## ➤ Detector Materials

- Photon Detectors
- Cryostat
- Others

- QUPID
- Copper (OHFC)
- PTFE, Quartz ...

## ➤ Purity of Liquid Xe/Ar

- Radon (< 0.3 mBq / ton)
- $^{39}\text{Ar}$  (> 100 depletion)
- $^{85}\text{K}$  (< 0.2 ppt in Xe)

- Depleted Ar
- 1 event / 10 ton-year

## ➤ Physics Backgrounds in Xe

- pp-chain solar neutrinos
- 2v Double beta decays from  $^{136}\text{Xe}$

- 1 event / 10 ton-year
- 1 event / 10 ton-year

# Where backgrounds come from?

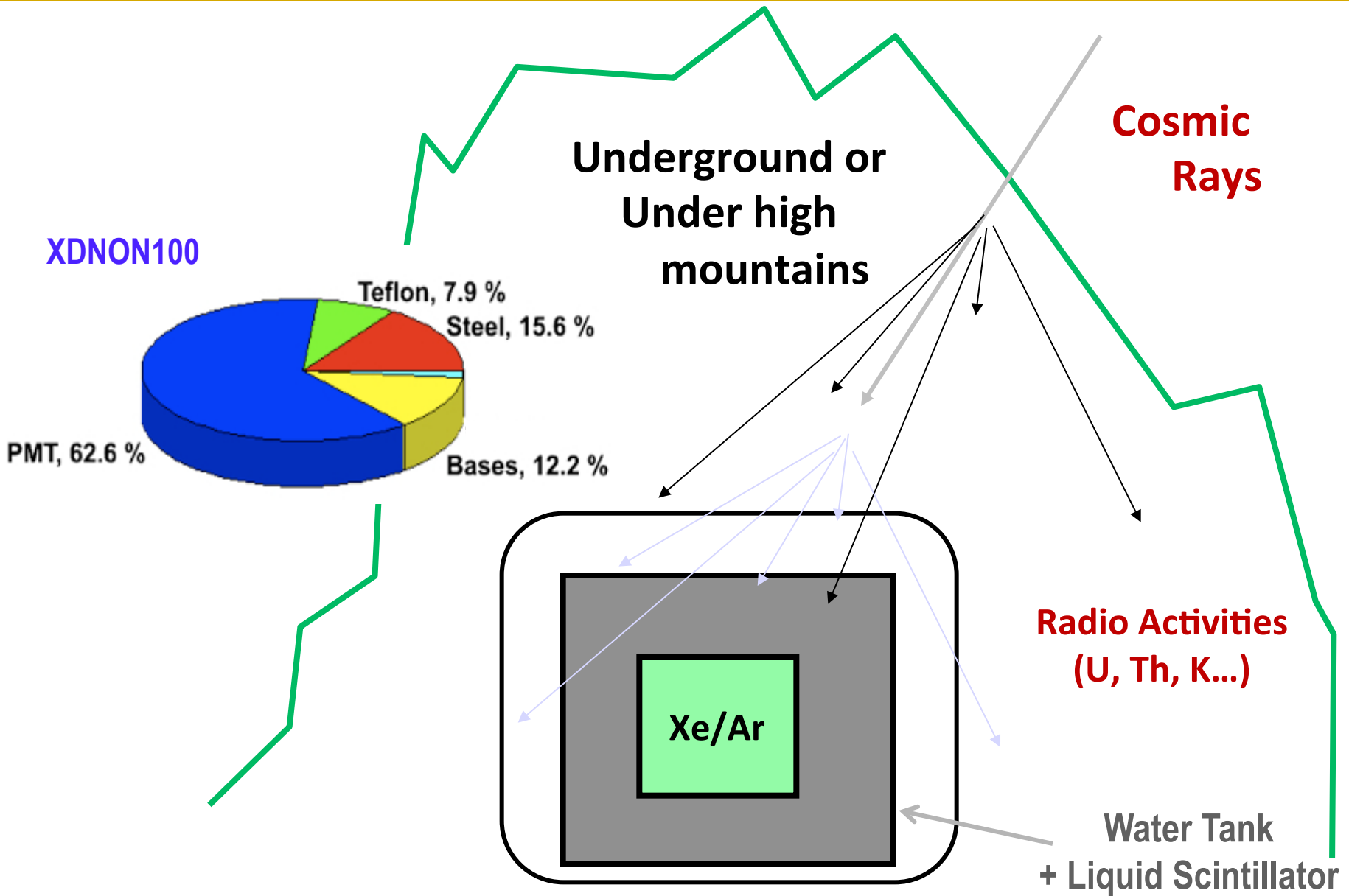

**Photon detectors are the major source of backgrounds.**

# QUPID (QUartz Photon Intensifying Detector)

arXiv:1103.3689

Photo Cathode  
(-6 kV)

Quartz

Al coating

APD (0 V)

Quartz

Photo Cathode  
(-6 kV)

APD (0 V)

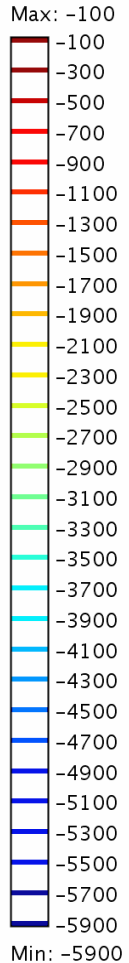

# Comparison of Photon Detectors from Hamamatsu

R11065 (Ar)  
R11410 (Xe)  
3 inch

XENON1T  
DarkSide50

QUPID  
3 inch

MAX  
XAX

R8520  
1 inch

XENON10  
XENON100

U/Th ~ 0.1 mBq

U/Th ~ 5 mBq

U/Th ~ 1 mBq

Confirmed by ICP/GD-MS

# QE of two types of QUPID

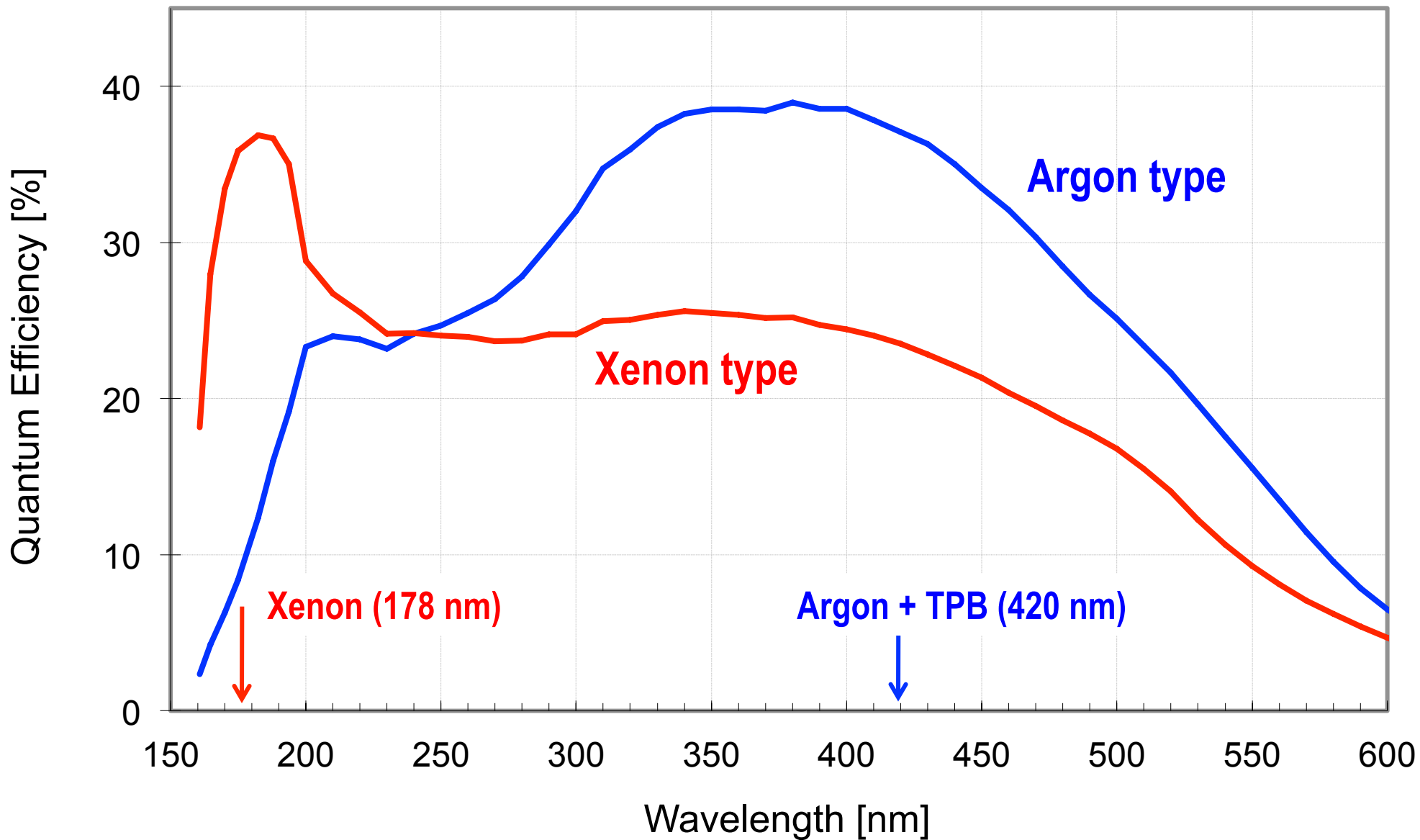

# 7 QUPID with Holder



**Tested in both Xe and Ar at UCLA**

7/25/2012

Kaisushi Arisaka, UCLA

# 1, 2 and 3 PE Distribution with 2 m cable

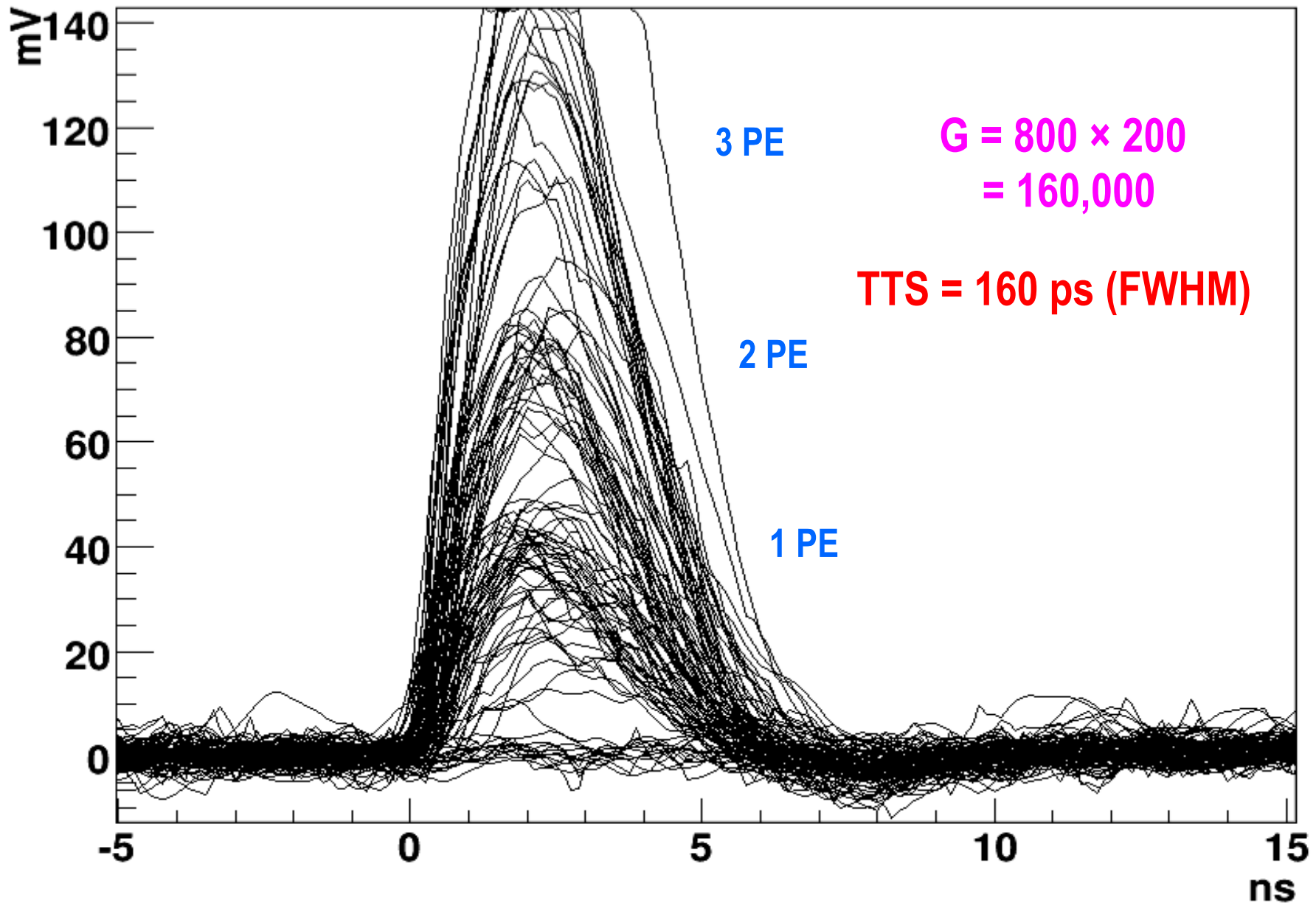

# PE Distribution up to 10 kV

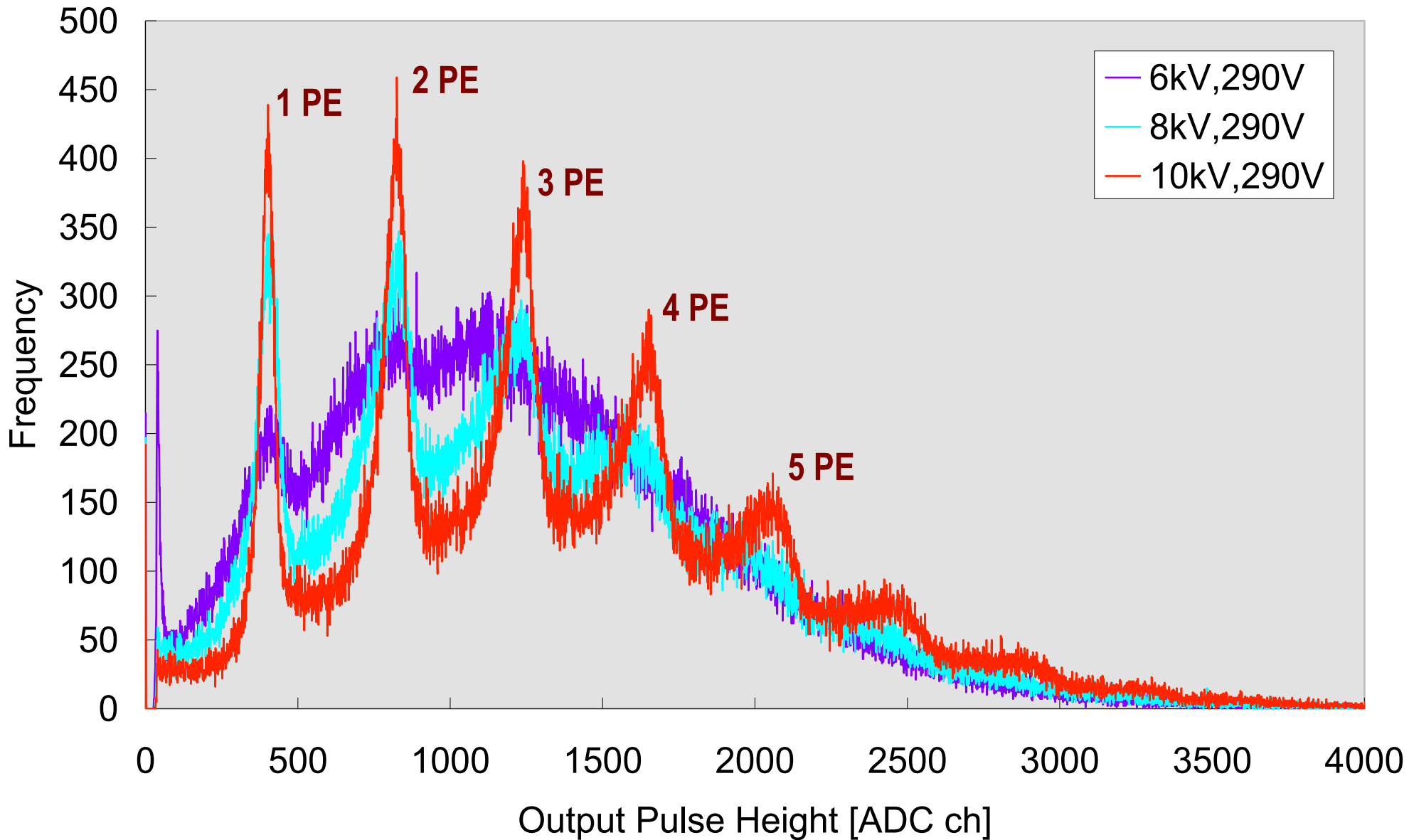

# Expected Background from Gammas and pp Solar Neutrinos (100 Year, Multi-hit Cut, S2/S1 Cut)

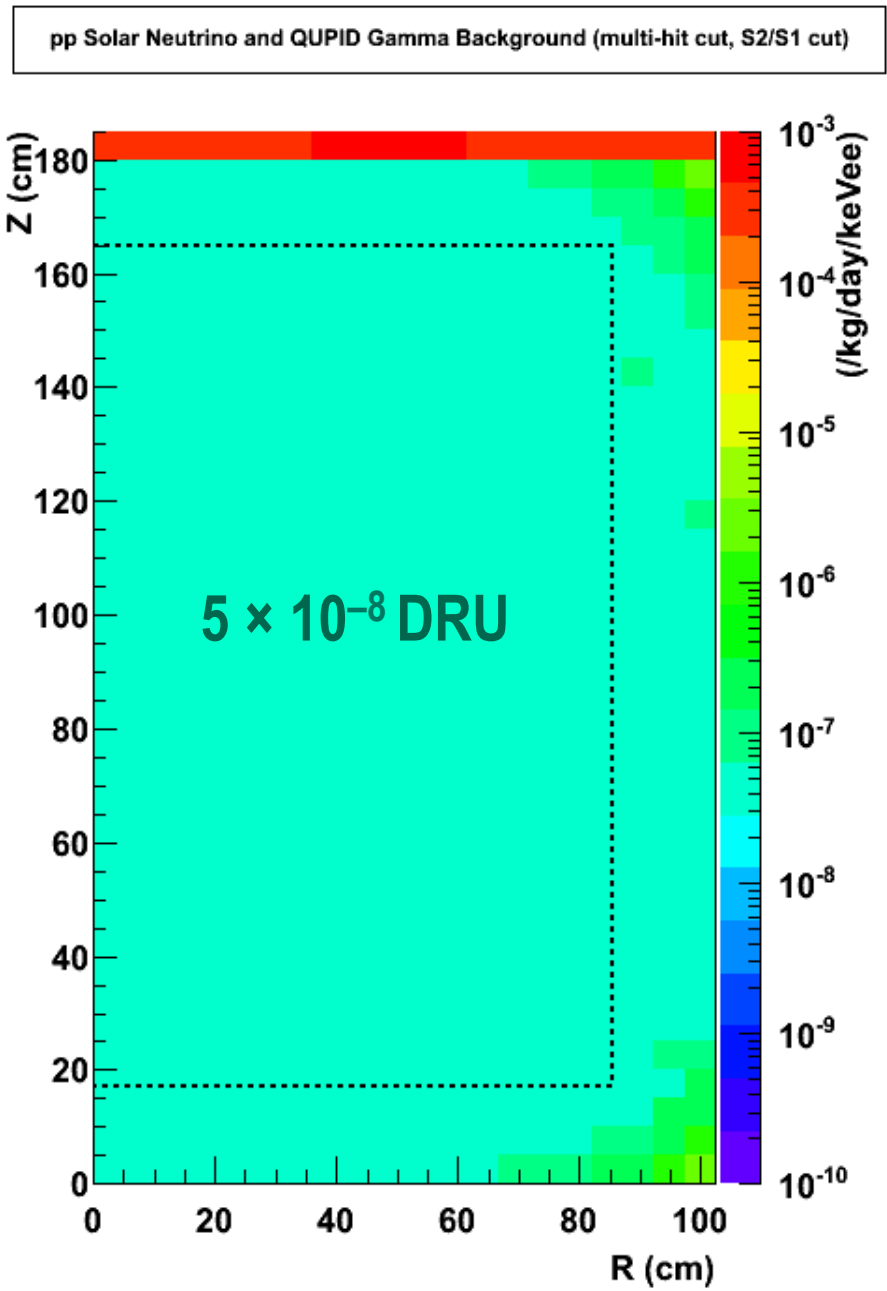
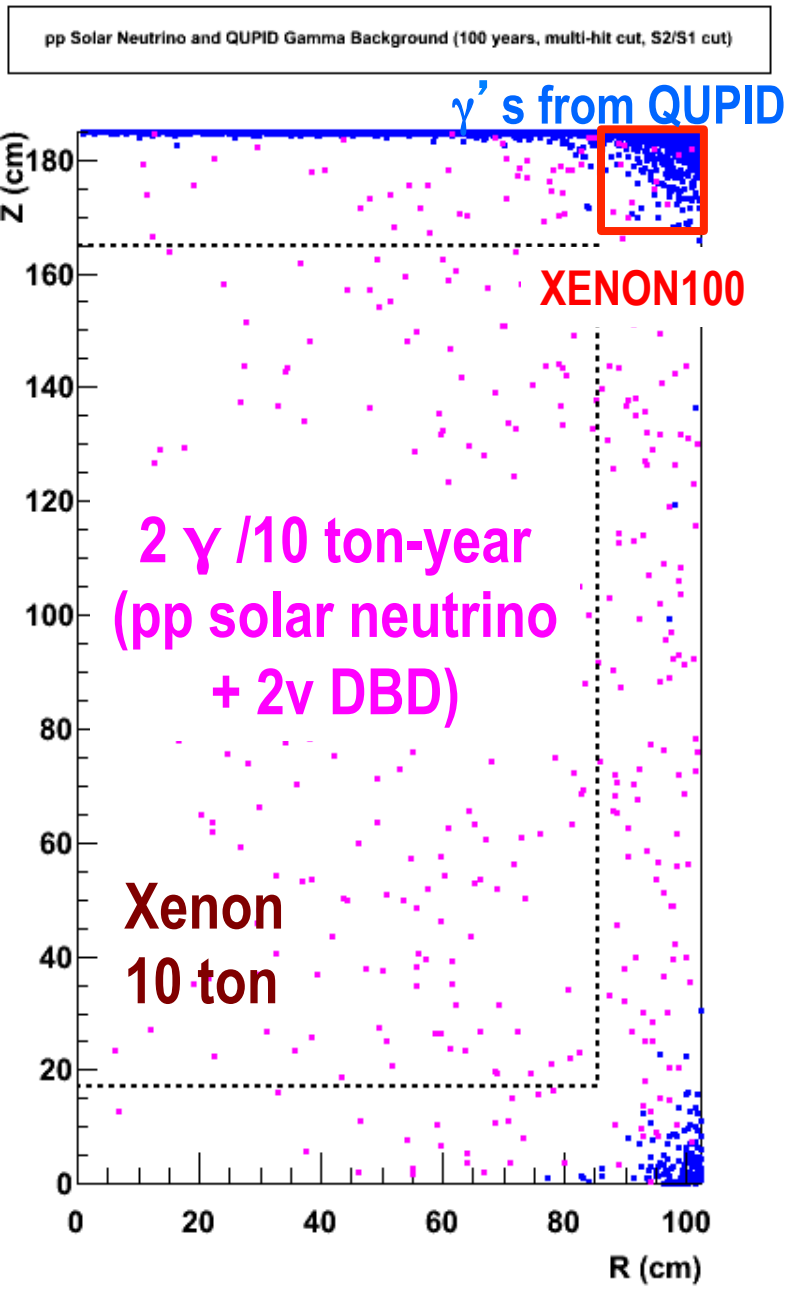

# Xe 10 ton Neutron Background (100 Years)

arXiv:1107.1295

Before Cuts

1/8

Multi Hit Cut

1/4

Liquid Scinti. Veto

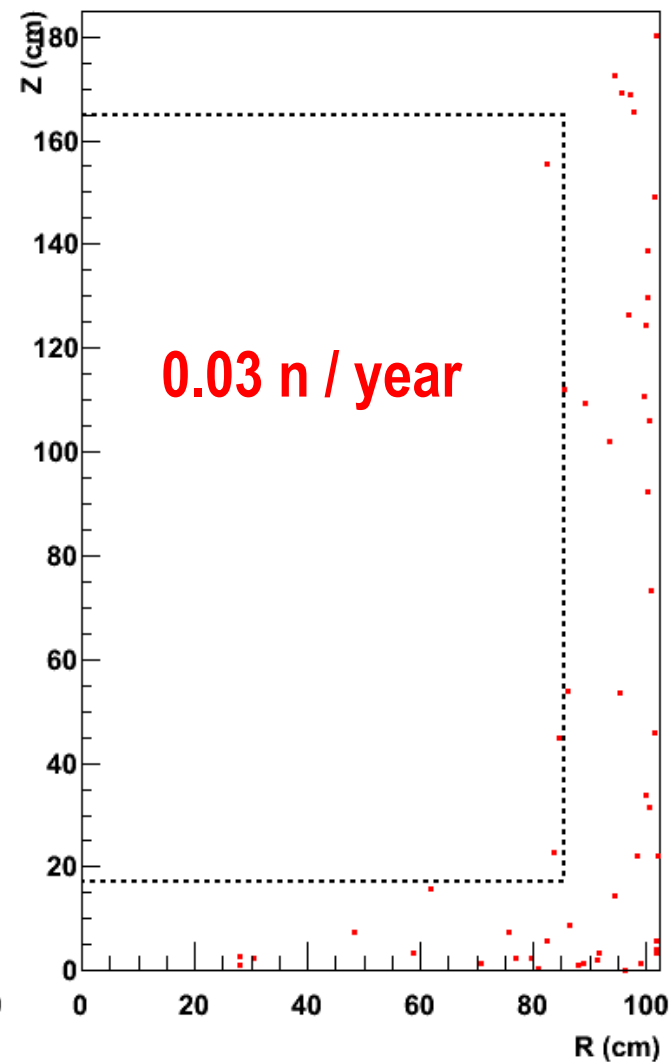
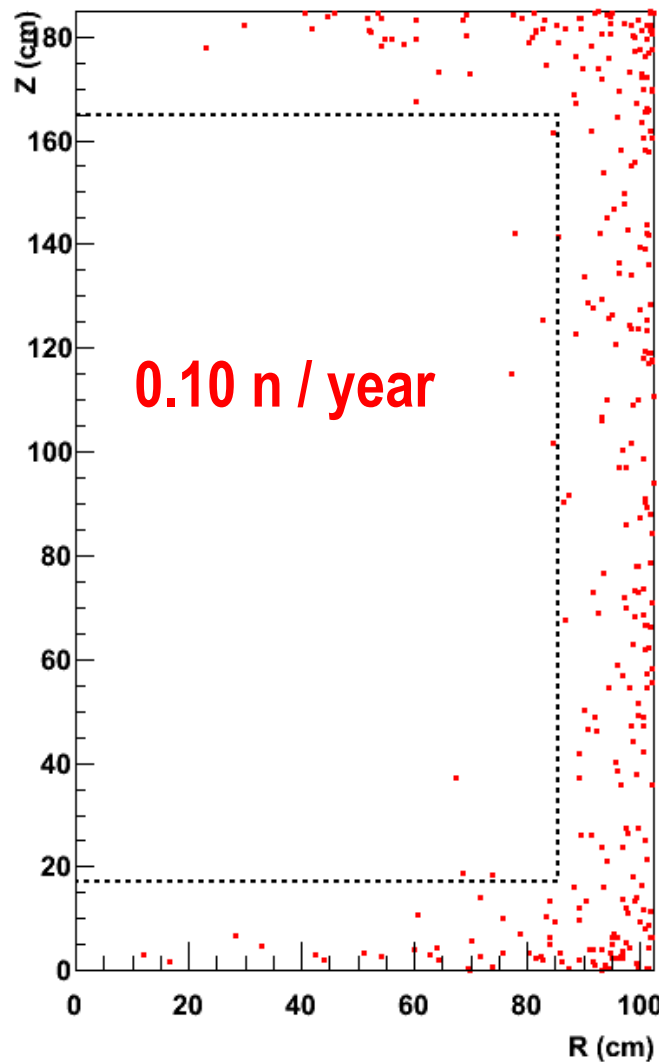
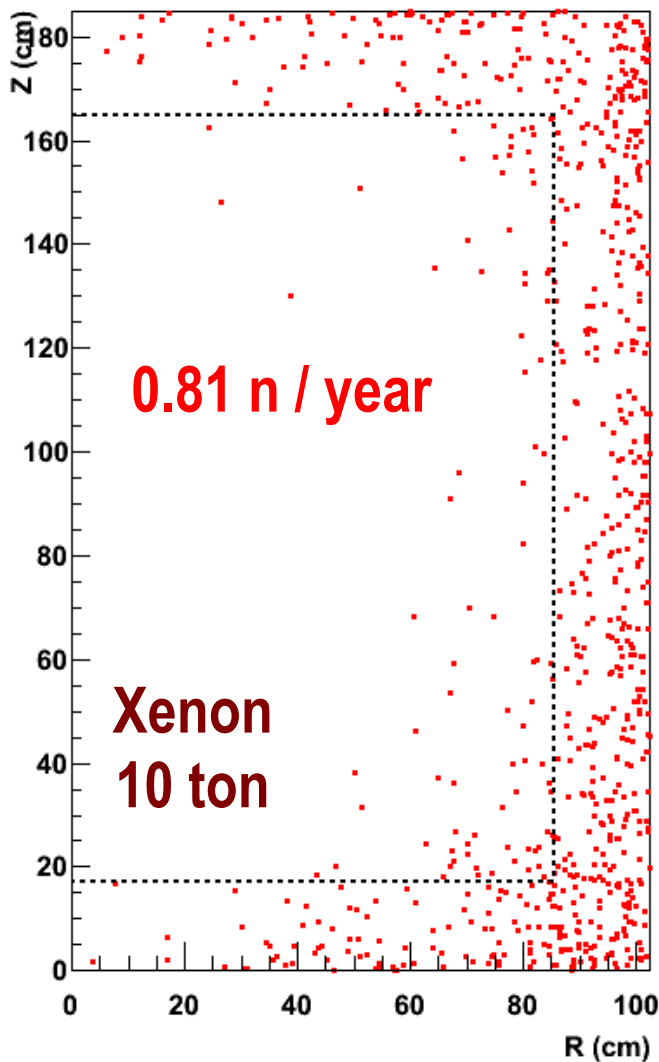

# Ar 50 ton Neutron Background (100 Years)

arXiv:1107.1295

Before Cuts

1/20

Multi Hit Cut

1/6

Liquid Scinti. Veto

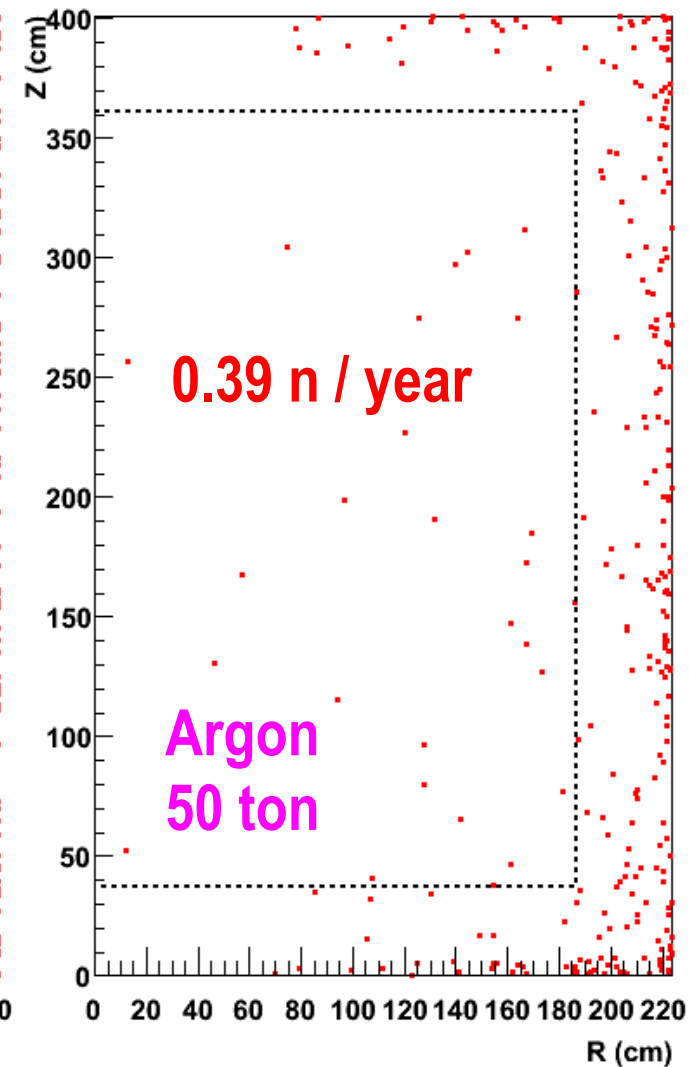
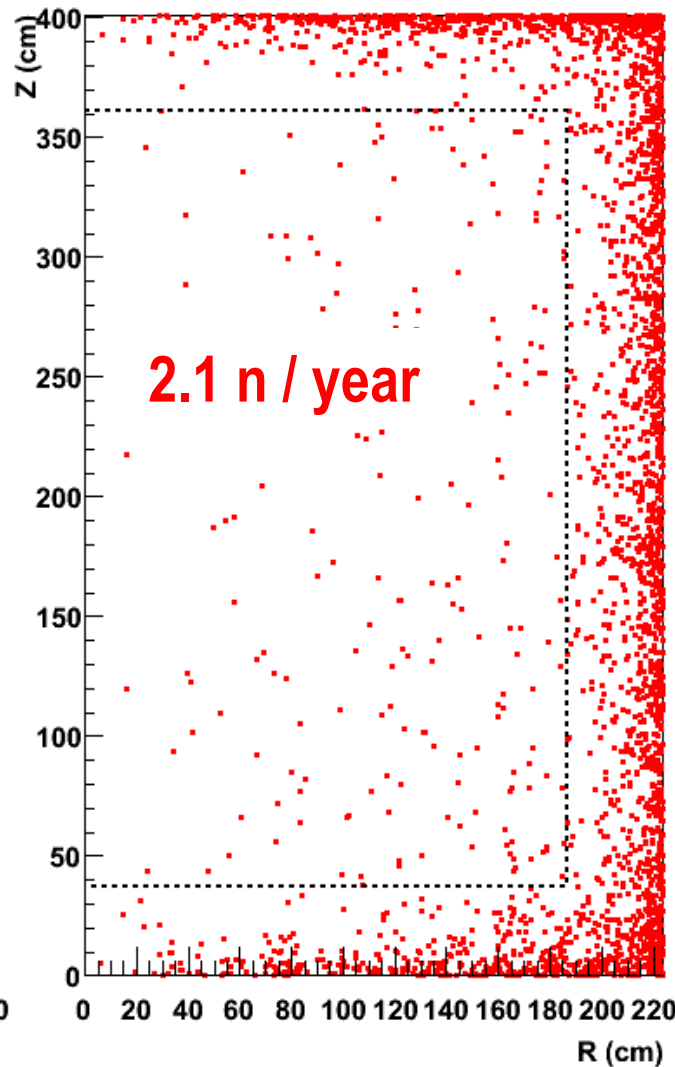
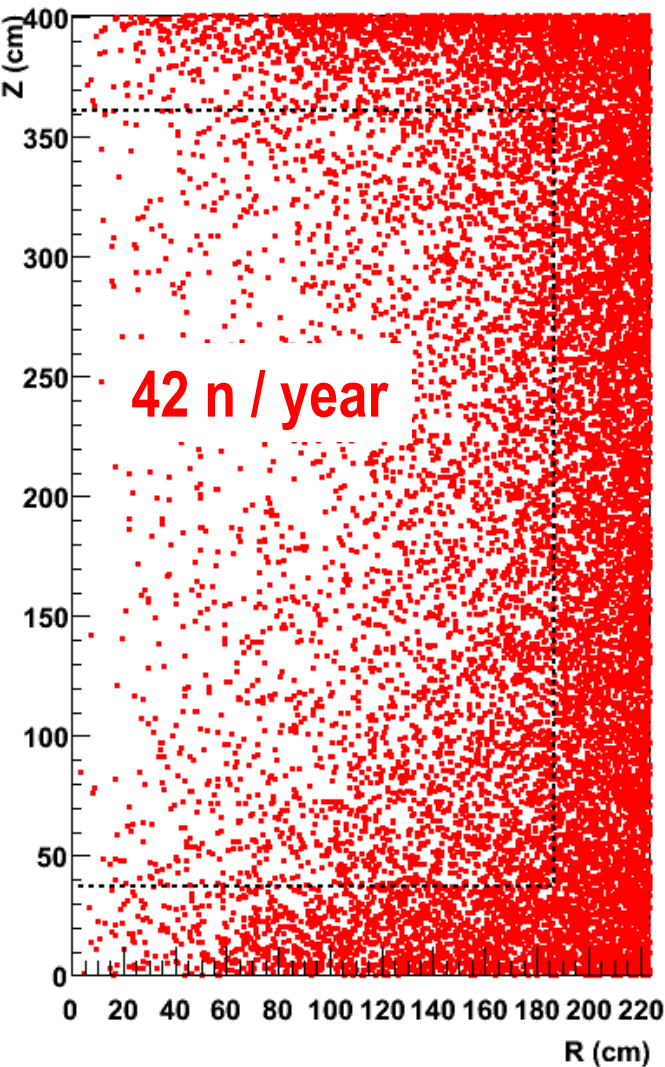

# XAX (Xenon-Argon-Xenon)

arXiv:0808.3968

*WIMP (Spin even)  
Double Beta Decay*

*WIMP (Spin odd)  
pp Solar Neutrino*

*WIMP (Spin even)*

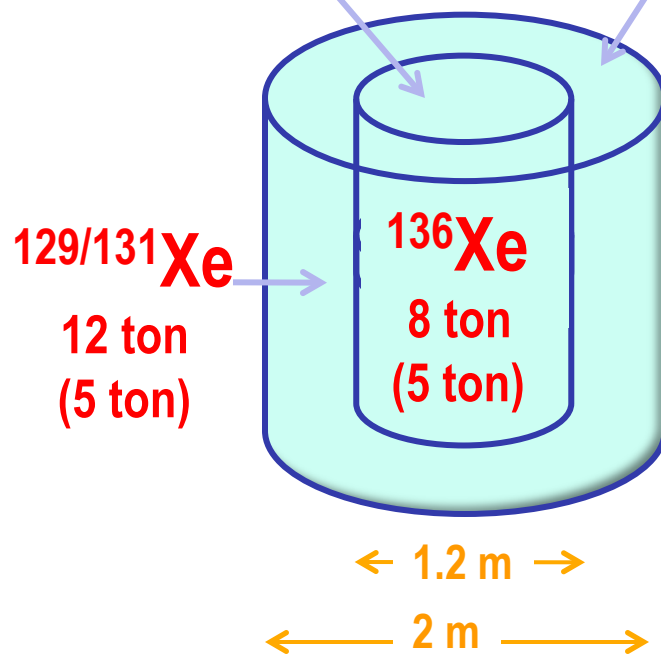

# Concept of Double Layer XAX

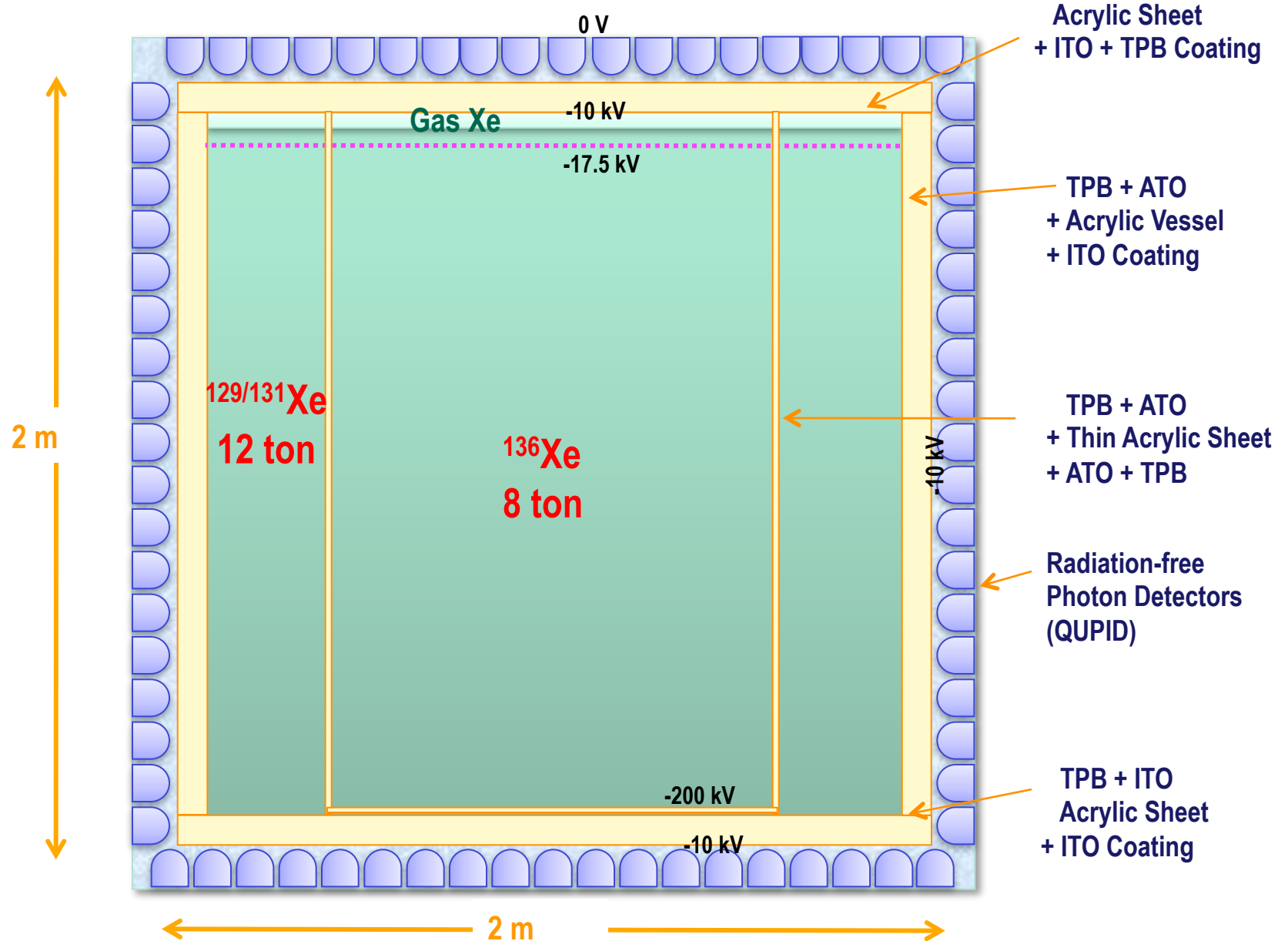

# Equipotential lines and Electron Trajectories

0 V →  
-6 kV →  
-13.5 kV →

-200 kV →  
-6 kV →  
0 V →

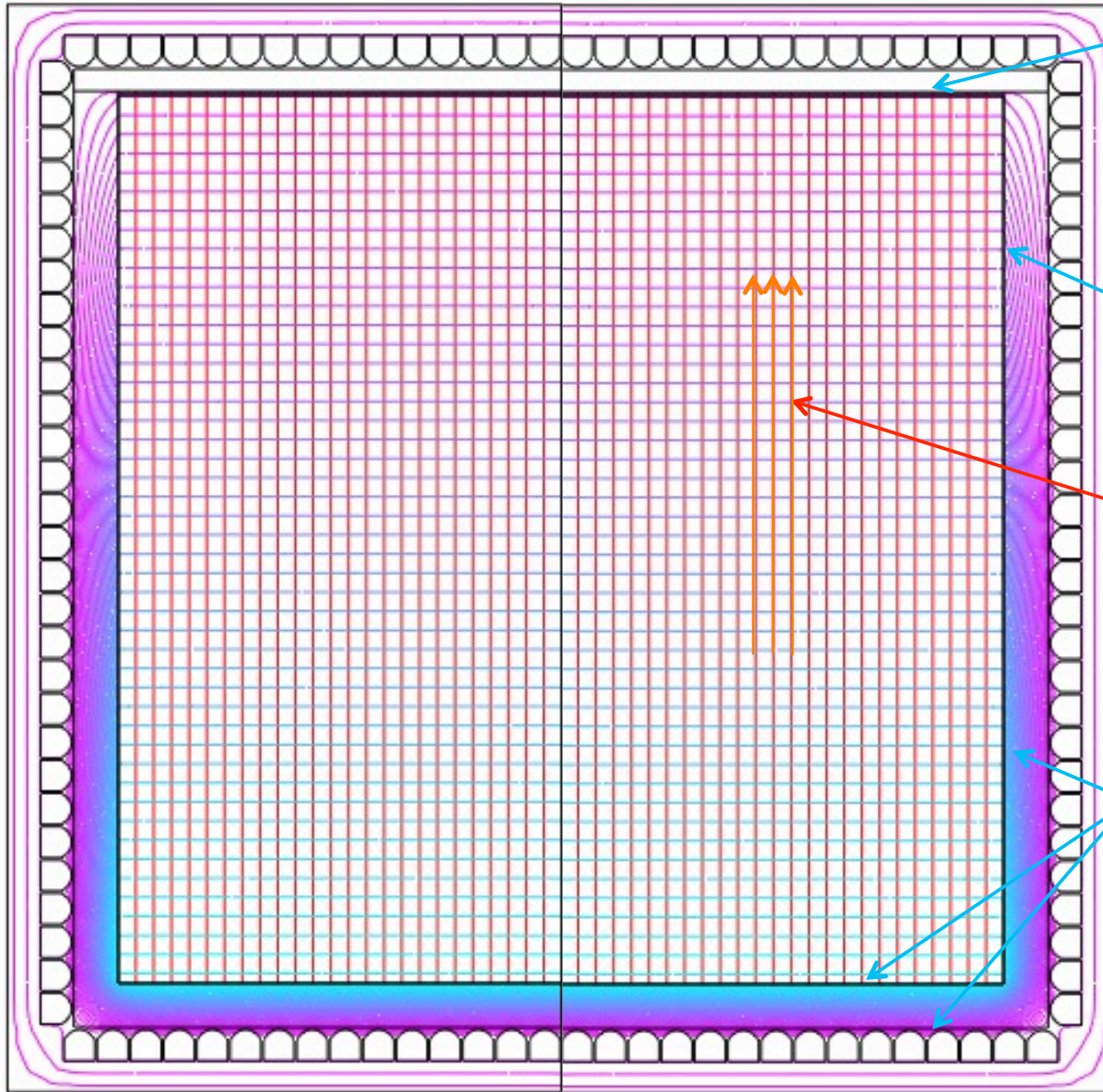

ITO (Indium Tin Oxide)  
Transparent Conductive  
Coating ( $\sim 1 \text{ k}\Omega/\square$ )

ATO (Antimony Tin Oxide)  
Transparent Resistive  
Coating ( $\sim 1 \text{ G}\Omega/\square$ )

Electron  
Trajectories

ITO (Indium Tin Oxide)  
Transparent Conductive  
Coating ( $\sim 1 \text{ k}\Omega/\square$ )

# Why Multiple Targets?

## ➤ Systematic Study of Dark Matter

- Precise determination of Mass and Cross section
  - Xenon vs. Argon
- Spin dependence of Cross section
  - $^{129/131}\text{Xe}$  (Spin odd) vs.  $^{132/134/136}\text{Xe}$  (Spin even)

## ➤ Low Energy Neutrino Physics

- Neutrino-less Double Beta Decay –  $\tau > 10^{28}$  by  $^{136}\text{Xe}$
- Solar Neutrino – 1% of pp chain flux by  $^{129/131}\text{Xe}$
- Supernova Neutrino – 10% of total  $E_\nu$  and  $T_\nu$

# Energy Spectrum (Natural Xe) arXiv:0808.3968

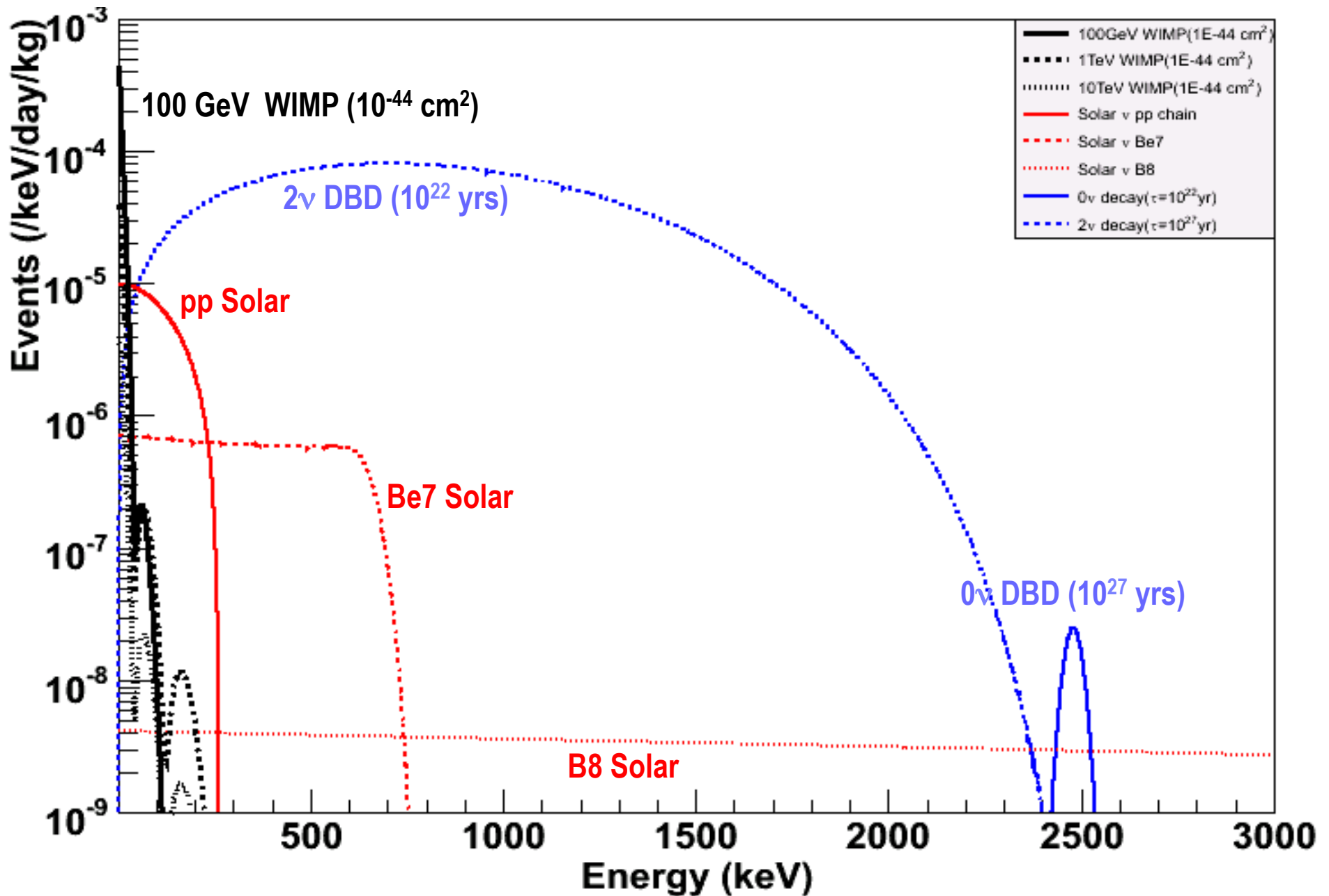

# Sensitivity of Neutrinoless Double Beta Decay to Neutrino Mass

## Normal Scheme

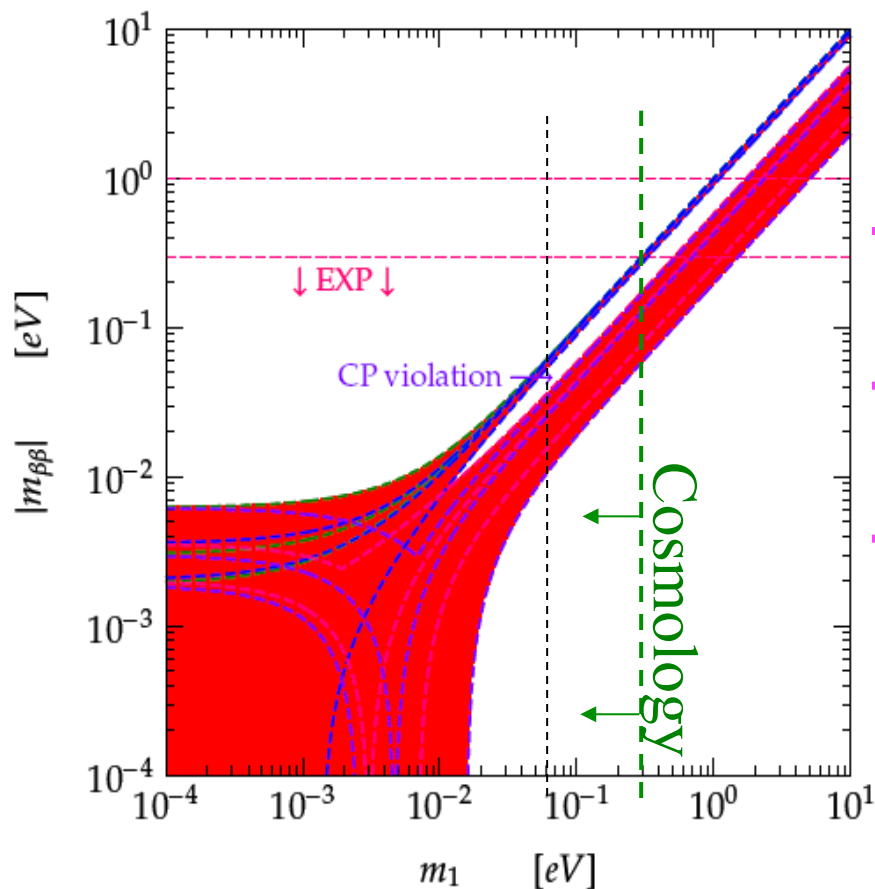

DBD  
Life Time

$10^{26}$  yr

$10^{27}$  yr

$10^{28}$  yr

## Inverted Scheme

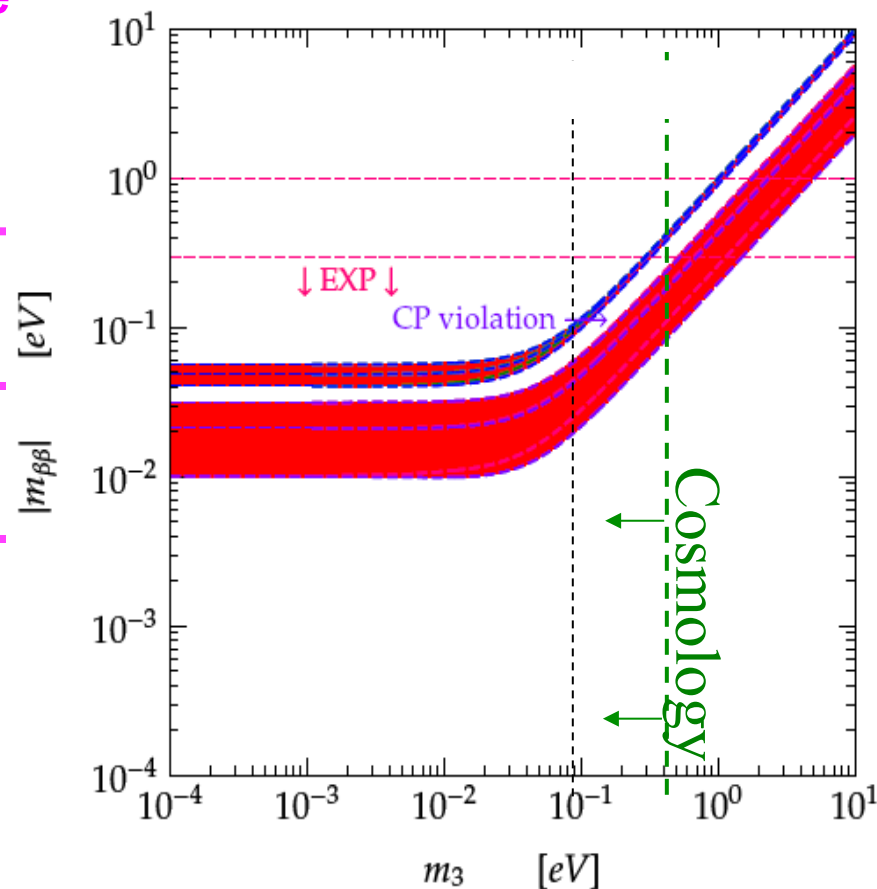

(Figure from C. Giunti)

# Expected No. of DBD Signals and Backgrounds (10 ton-year of Liquid Xenon, Window = $2479 \pm 25$ keV)

No. of Background Events

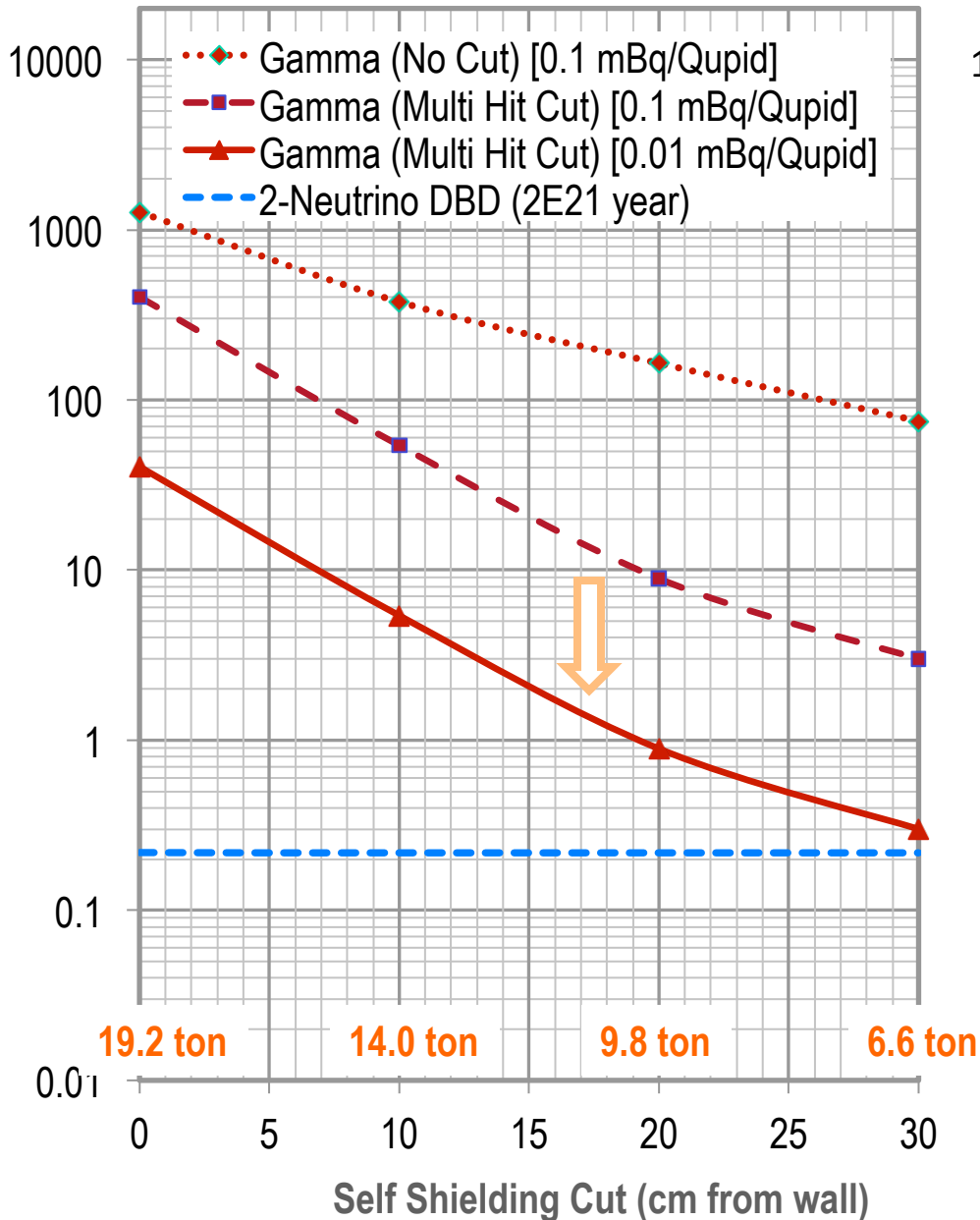

No. of 0-Neutrino DBD Signals

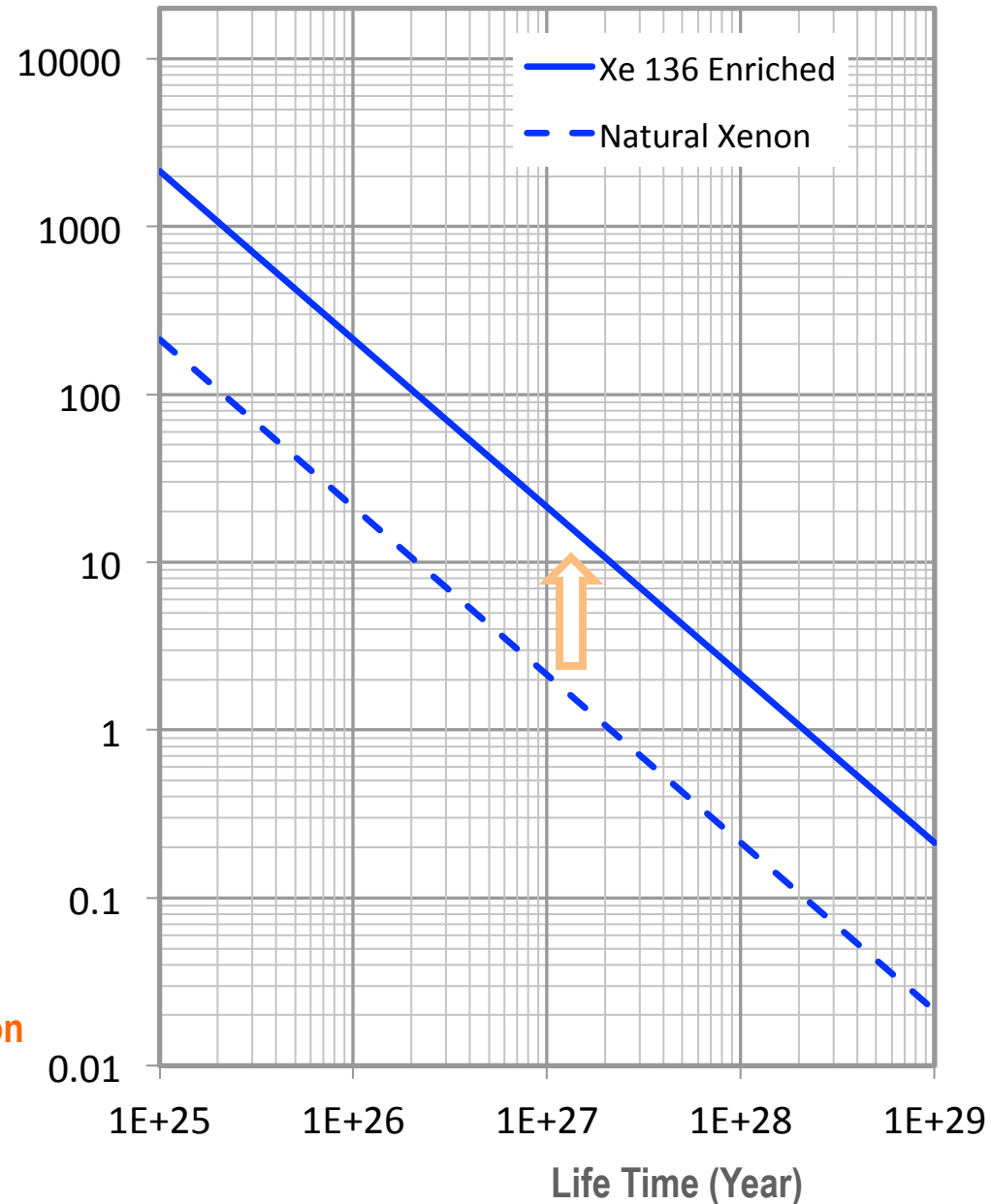

# Double Beta Decay Experiments (with $<0.03$ mBq QUPID)

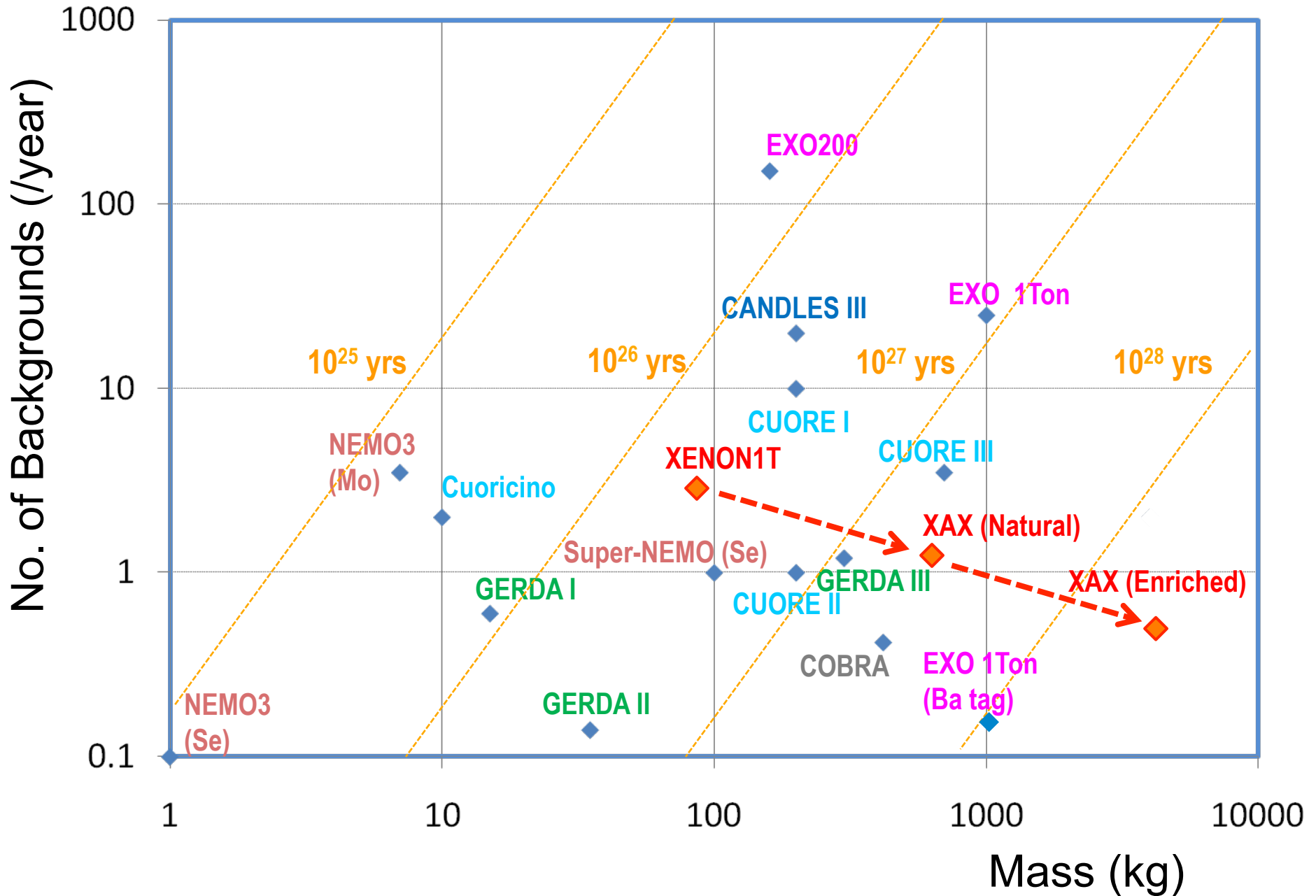

# Solar Neutrino Energy Spectrum ( $^{136}\text{Xe}$ depleted)

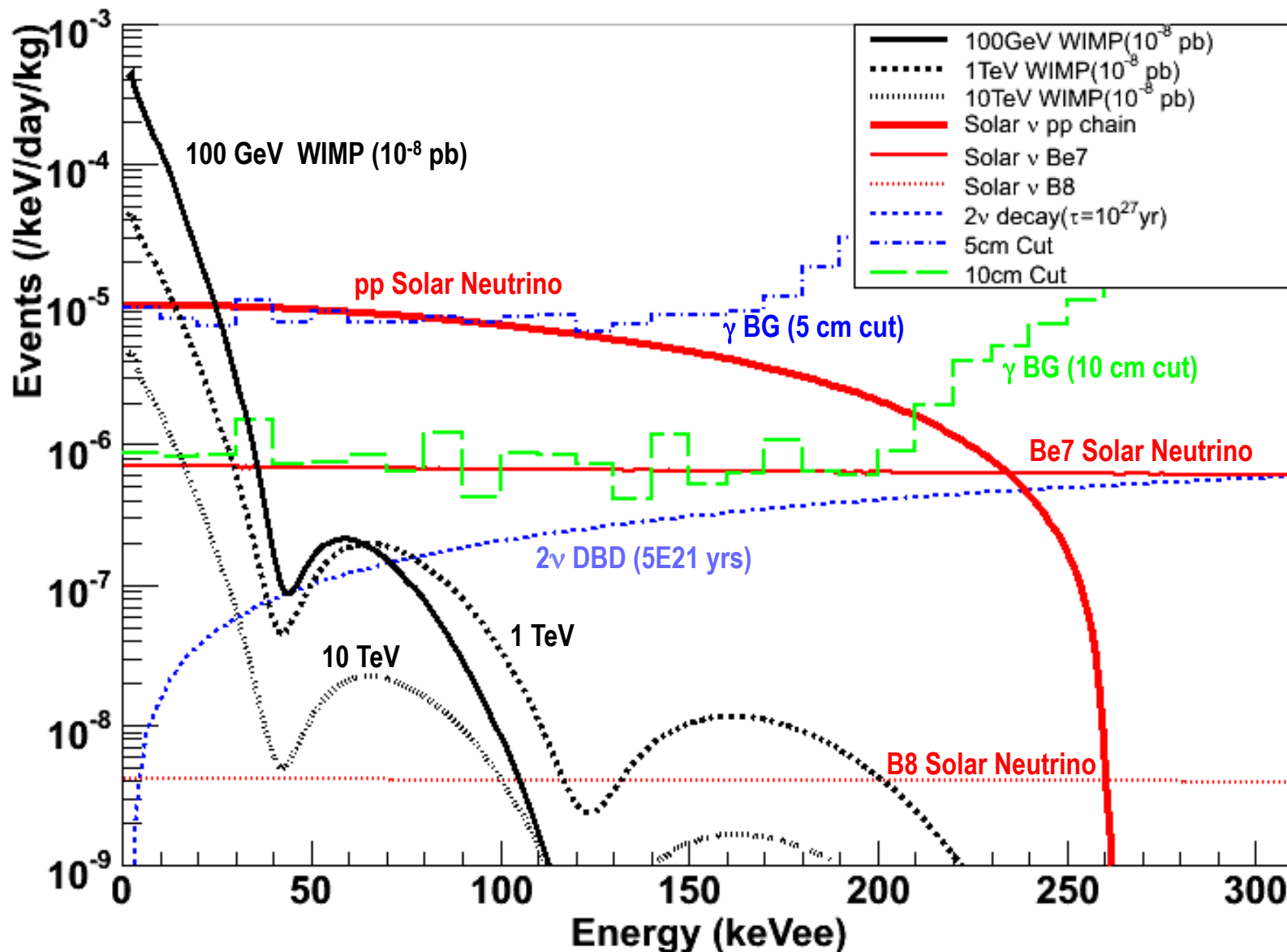

# Solar Neutrino with a Magnetic Dipole Moment or a New Light Gauge Boson $A'$

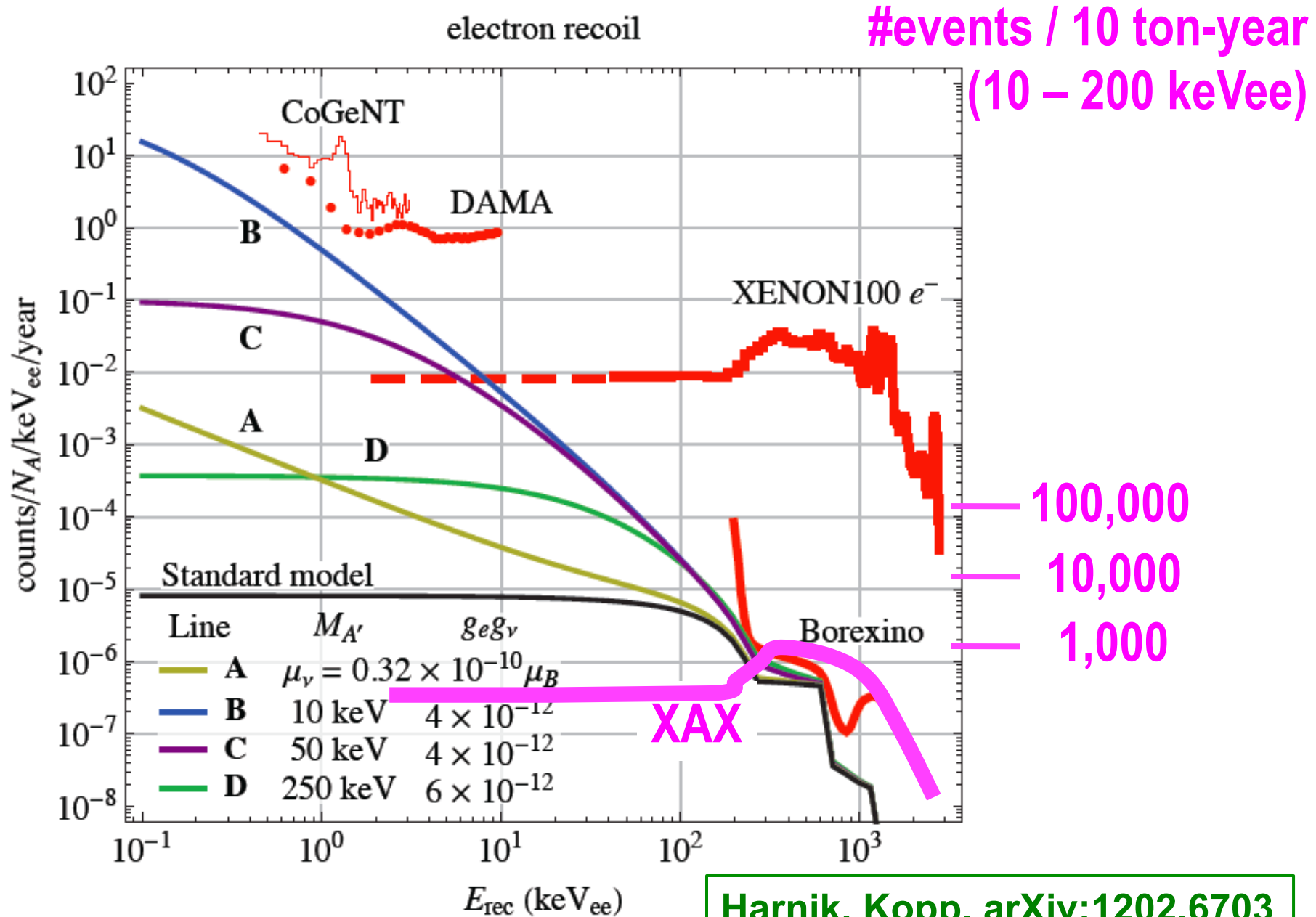

# Solar Neutrino with a Heavy Sterile Neutrino

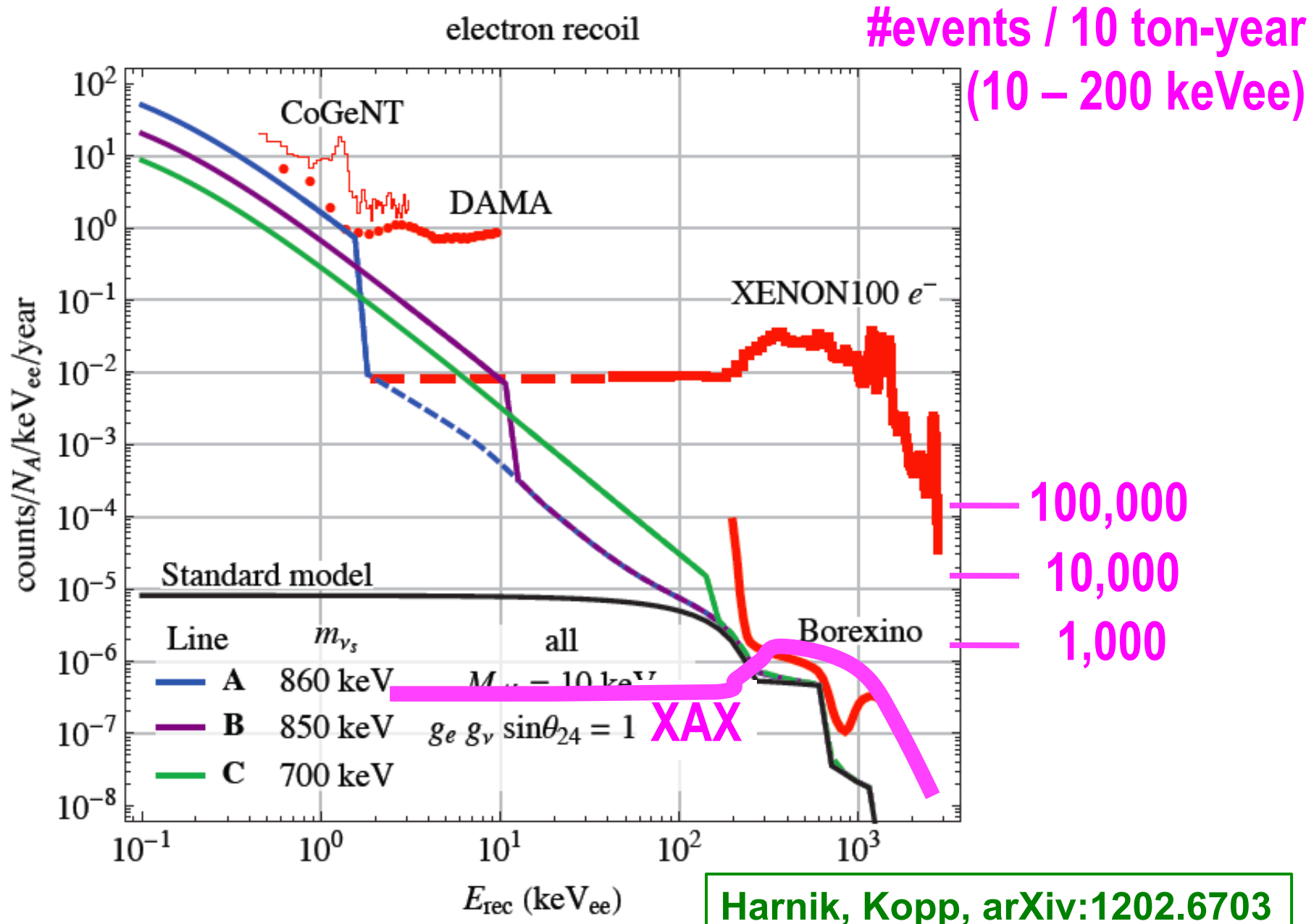

# Summary of MAX & XAX

	XENON1T	DarkSide G2	MAX		XAX	
	Xenon	Argon	Xenon	Argon	<sup>129/131</sup> Xe	<sup>136</sup> Xe (80%)
<b>Dimension</b>						
<i>Detector Size</i>	1m x 1m	1.6m x 1.6m	2m x 2m	4m x 4m	2m x 2m	
<i>Total Mass</i>	2.2 ton	5 ton	20 ton	70 ton	12 ton	8 ton
<i>Fiducial Mass</i>	1.1 ton	3 ton	10 ton	50 ton	5 ton	5 ton
<b>QUPID</b>						
<i>Top</i>	130 (3")	300 (3")	595 (3")	661 (6")	595 (3")	
<i>Side</i>	0	0	672 (6")	2423 (6")	672 (6")	
<i>Bottom</i>	121 (3")	300 (3")	163 (6")	661 (6")	163 (6")	
<b>No.WIMP / year (<math>10^{-45} \text{ cm}^2</math>)</b>						
<i>Mass = 20 GeV</i>	23	–	230	–	115	115
<i>50 GeV</i>	71	15	710	250	355	355
<i>100 GeV</i>	56	25	560	420	280	280
<i>200 GeV</i>	33	22	330	360	165	165
<i>500 GeV</i>	14	11	140	190	70	70
<b>Backgrounds / year</b>						
<i>Gammas</i>	0.07	0.00	0.01	0.00	0.07	0.01
<i>Neutrons (w/o LS)</i>	0.10	0.5	0.10	2.1	0.10	0.00
<i>Neutrons (w/ LS)</i>	–	0.06	0.03	0.39	0.03	0.00
<b>Neutrinos / year</b>						
<i><math>0\nu</math> DBD (<math>10^{27} \text{ yr}</math>)</i>	0.4	–	3.3	–	–	38
<i>pp-solar</i>	–	–	–	–	2500	–
<i>Supernova (10 kpc)</i>	11	8	95	141	48	48

# Conclusions

## ➤ MAX

- **10 Ton Xe + 50 Ton Ar**
- Consortium between **XENON** and **DarkSide**
- Sensitivity down to  **$10^{-48} \text{ cm}^2$**
- Precision measurements if  $> 10^{-46} \text{ cm}^2$

## ➤ XAX

- **5 Ton  $^{136}\text{Xe}$  + 50 Ton Ar + 5 Ton  $^{129/131}\text{Xe}$**
- Neutrino-less Double Beta Decay –  $\tau > 10^{28}$  by  $^{136}\text{Xe}$
- Solar Neutrino – 1% of pp chain flux by  $^{129/131}\text{Xe}$ .
- Supernova Neutrino – 10% of total  $E_\nu$  and  $T_\nu$