

Why are we here?

Origin of Universe and Ourselves

Katsushi Arisaka

***University of California, Los Angeles
Department of Physics and Astronomy***

arisaka@physics.ucla.edu



Why are we here?

Solar System

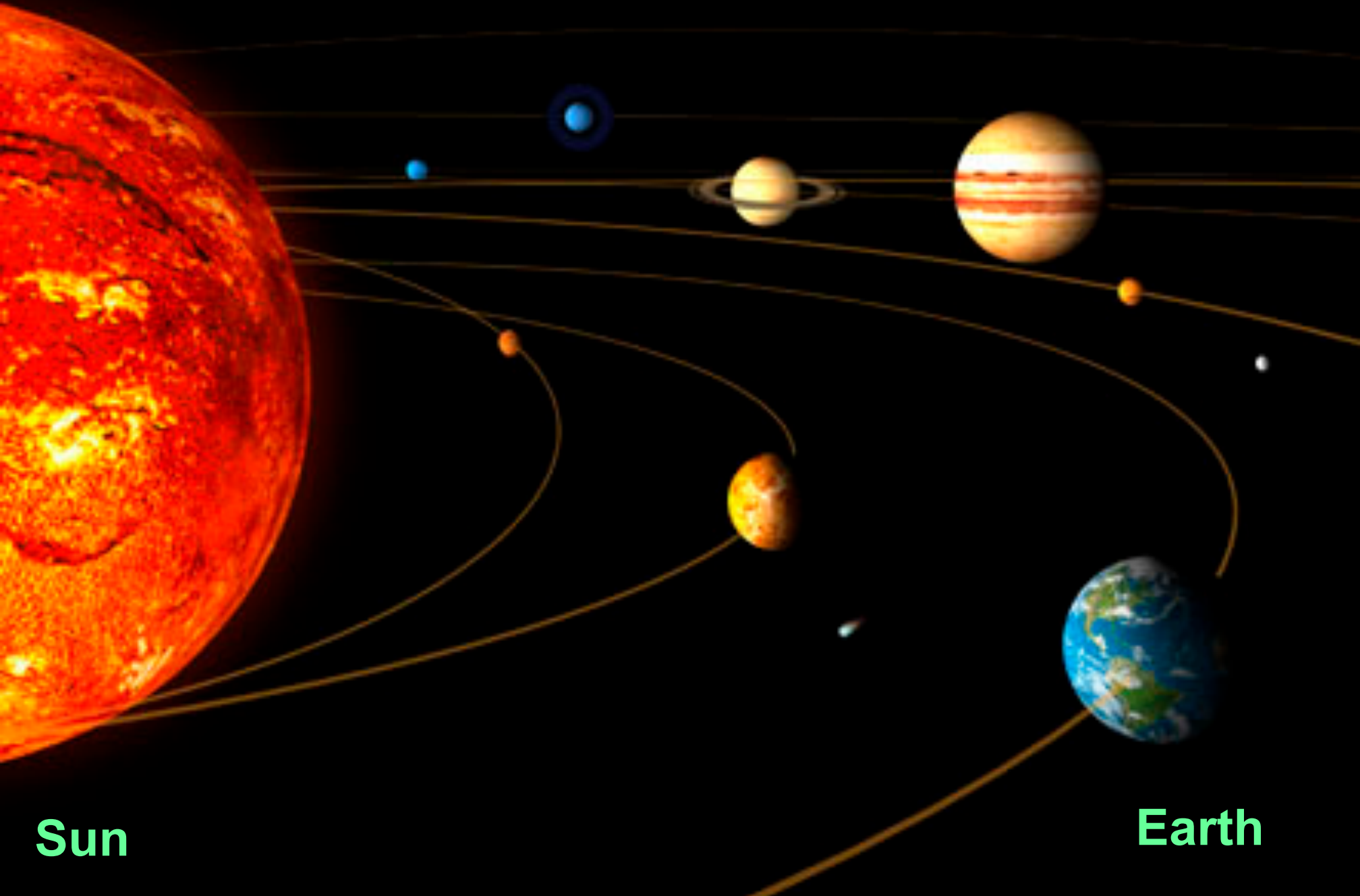

Sun

Earth

Andromeda



~100 Billions Stars in a Galaxy

Hubble Deep Field

The image displays a vast field of galaxies, known as the Hubble Deep Field. It features a dense collection of galaxies in various colors, including yellow, orange, red, blue, and purple, set against a dark, starry background. The galaxies vary in size and shape, with some appearing as bright, distinct points of light and others as more complex, multi-lobed structures. The overall appearance is that of a rich, multi-colored population of galaxies.

~100 Billion Galaxies

Hubble Deep Field

The image displays a dense field of galaxies, including various shapes like spirals, ellipticals, and irregular forms. The colors range from bright yellow and orange to deep blue and purple. A prominent bright star with a four-pointed diffraction pattern is visible in the lower-left quadrant. The background is a dark, almost black space filled with numerous smaller, fainter galaxies.

Red shift
up to ~ 10

A pink arrow originates from the text and points towards a small, faint galaxy located in the upper-right quadrant of the image.

~ 100 Billion Galaxies

Hubble's Law: Expansion of the Universe

Big Bang!

Horizon
of Universe

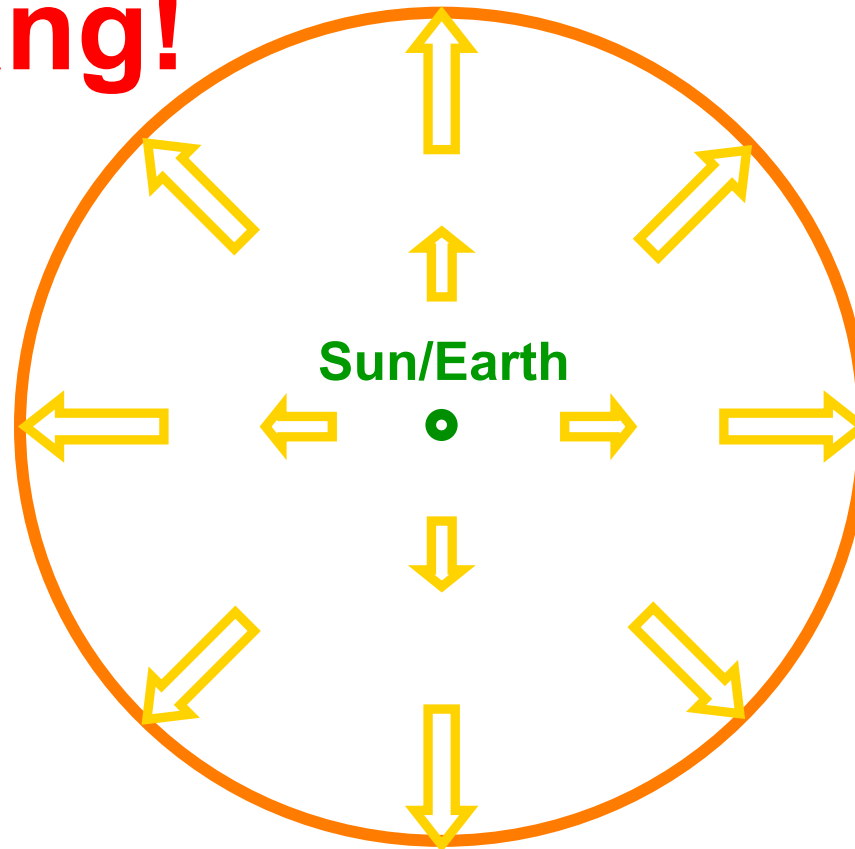

**14 Billion
Light Years**

**Moving Away
at Speed of Light**

Expansion of Universe

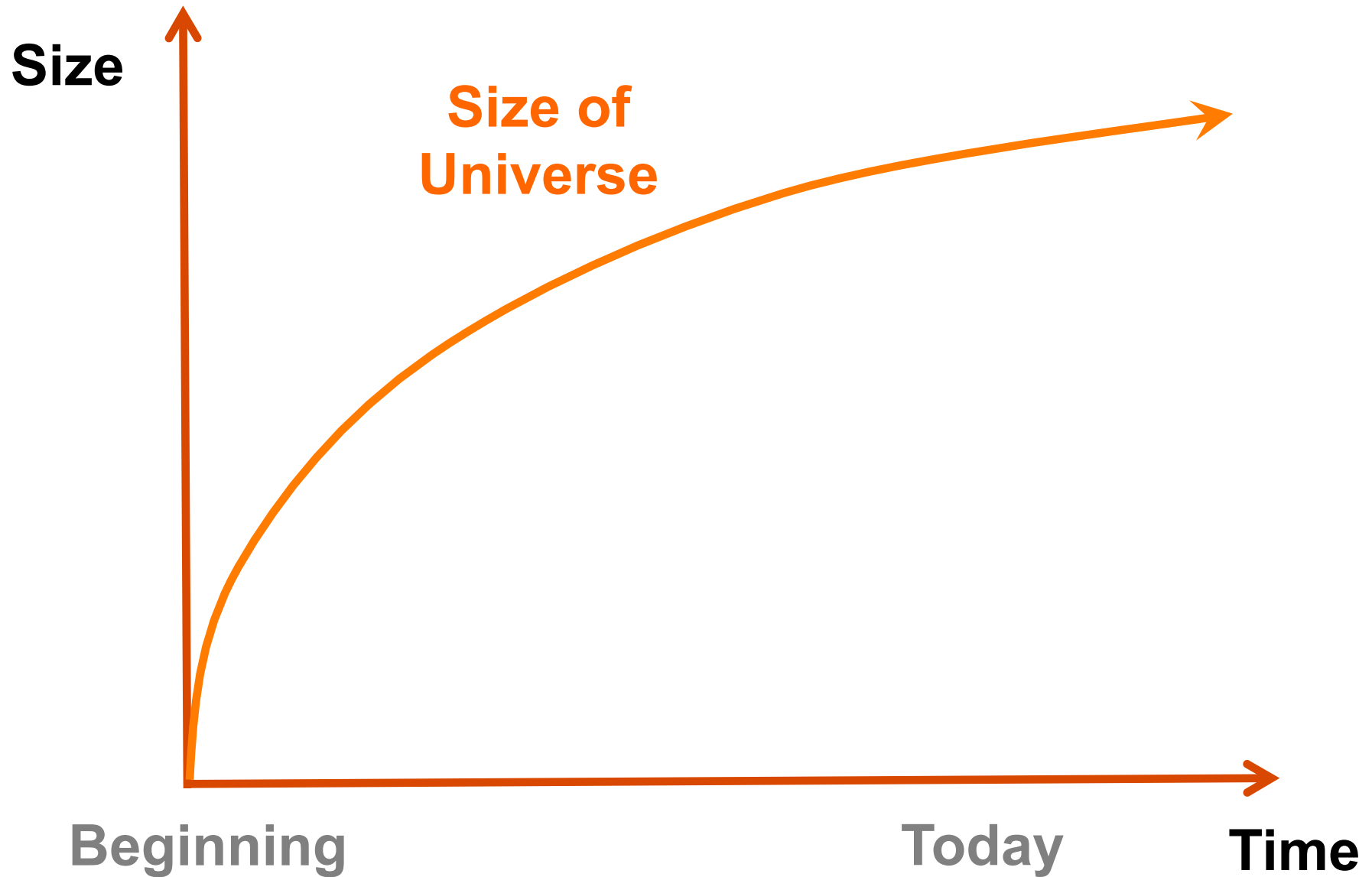

Temperature of Universe

Temperature

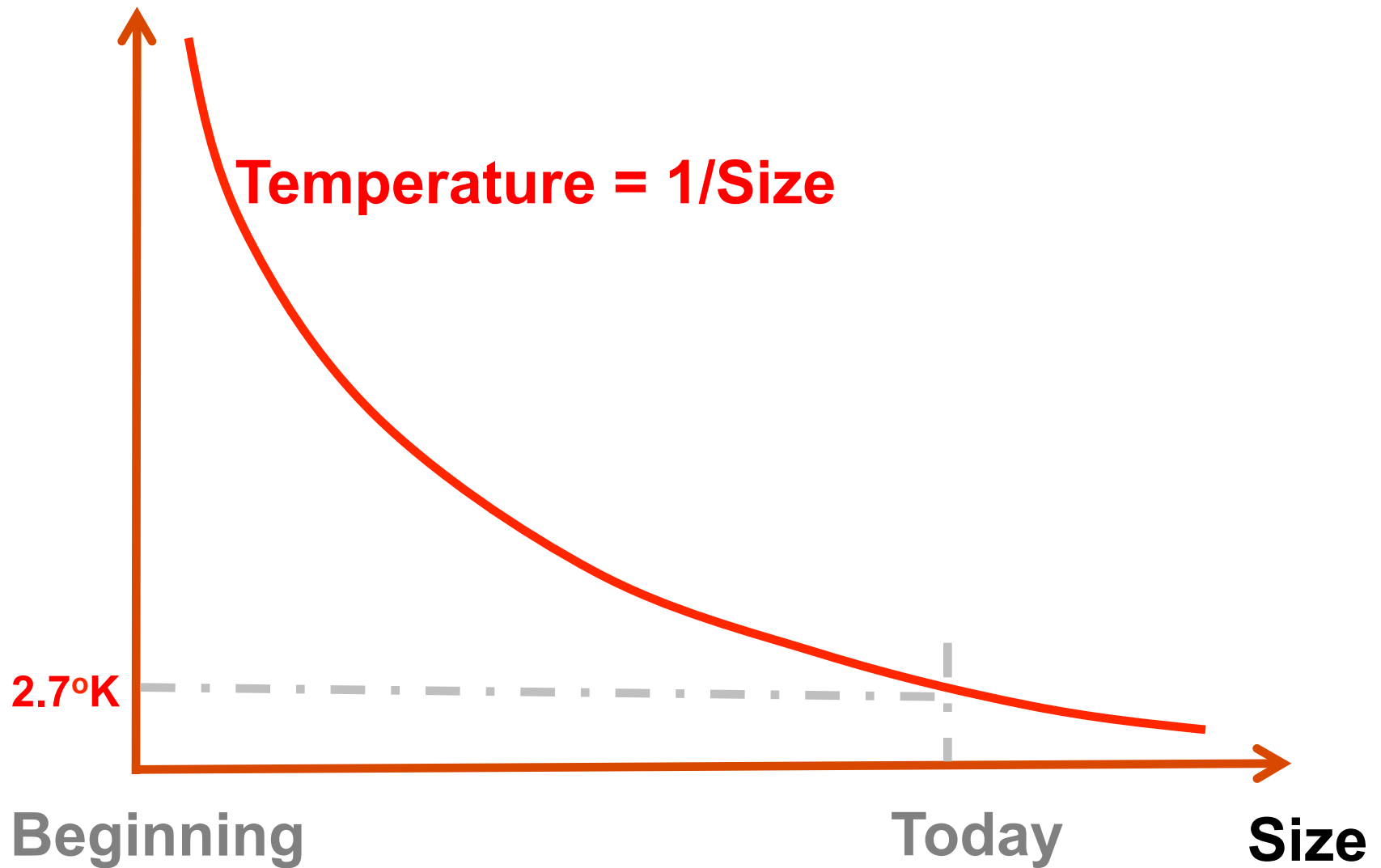

Tevatron at Fermi Lab near Chicago (1980 – 2010)



6km Circumference

Elementary Particles

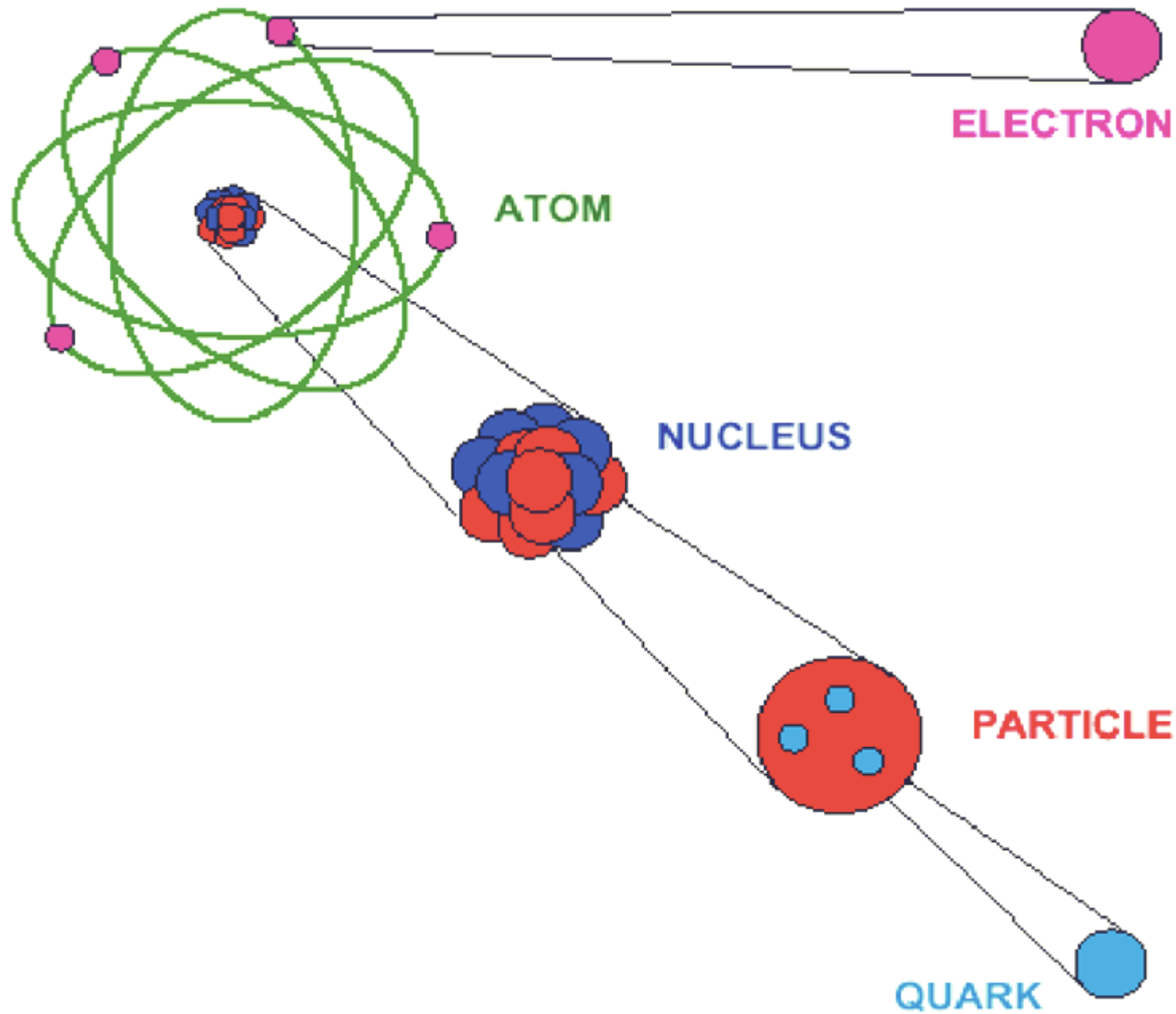

Quark Model

Proton

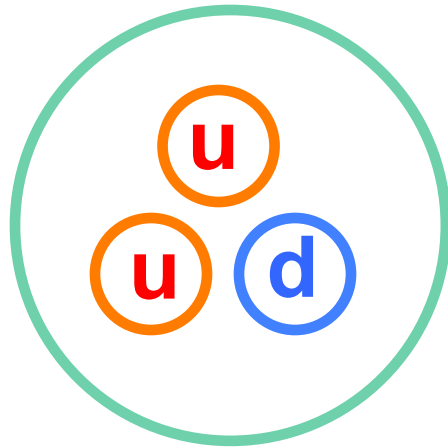

$$+ 2/3 + 2/3 - 1/3 = 1$$

Neutron

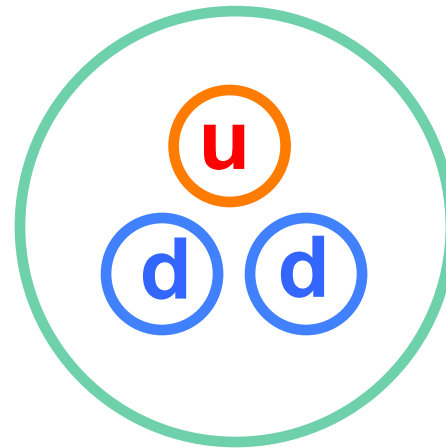

$$+ 2/3 - 1/3 - 1/3 = 0$$

Unification of Forces

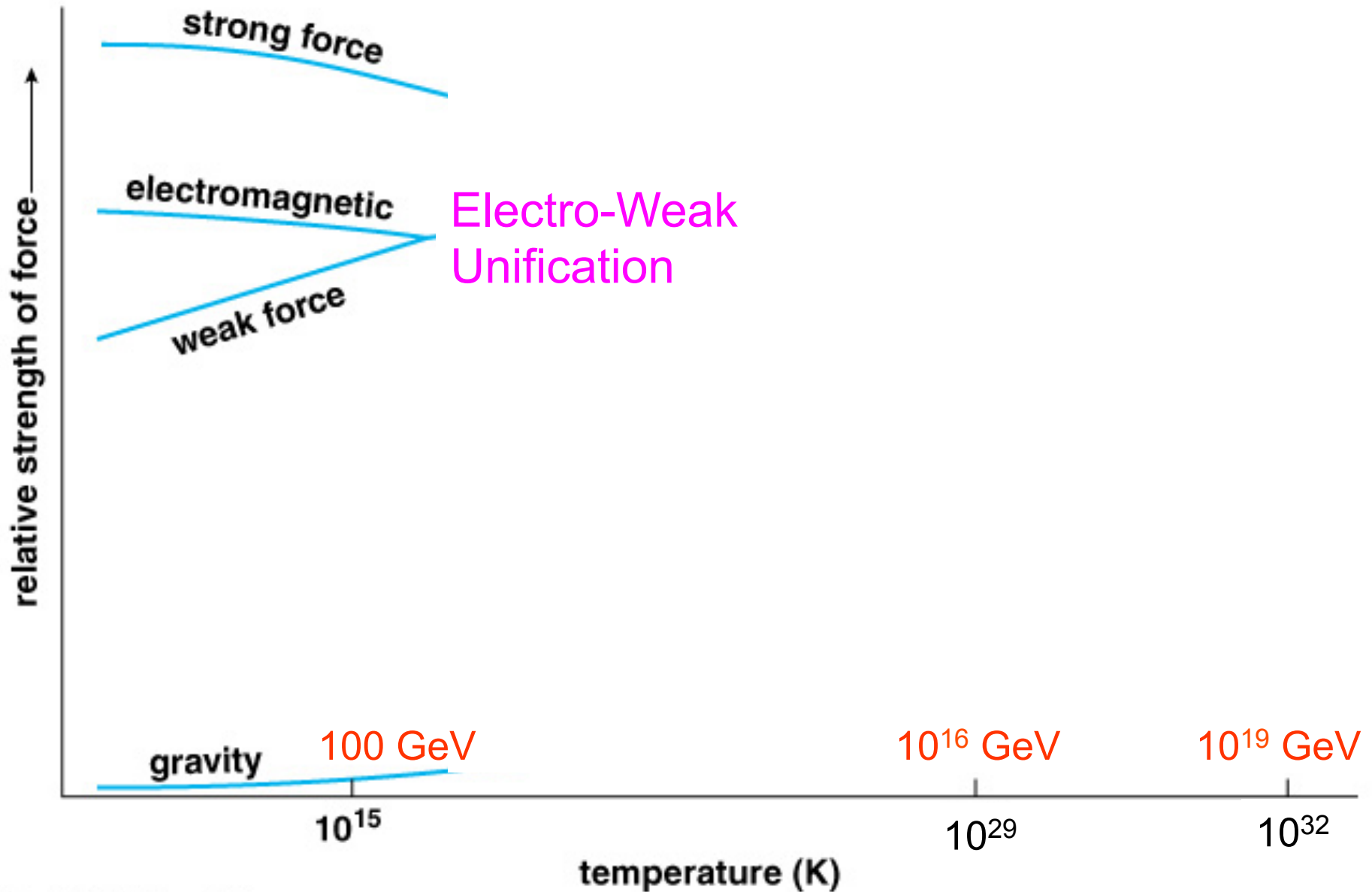

Copyright © Addison Wesley.

Unification of Forces

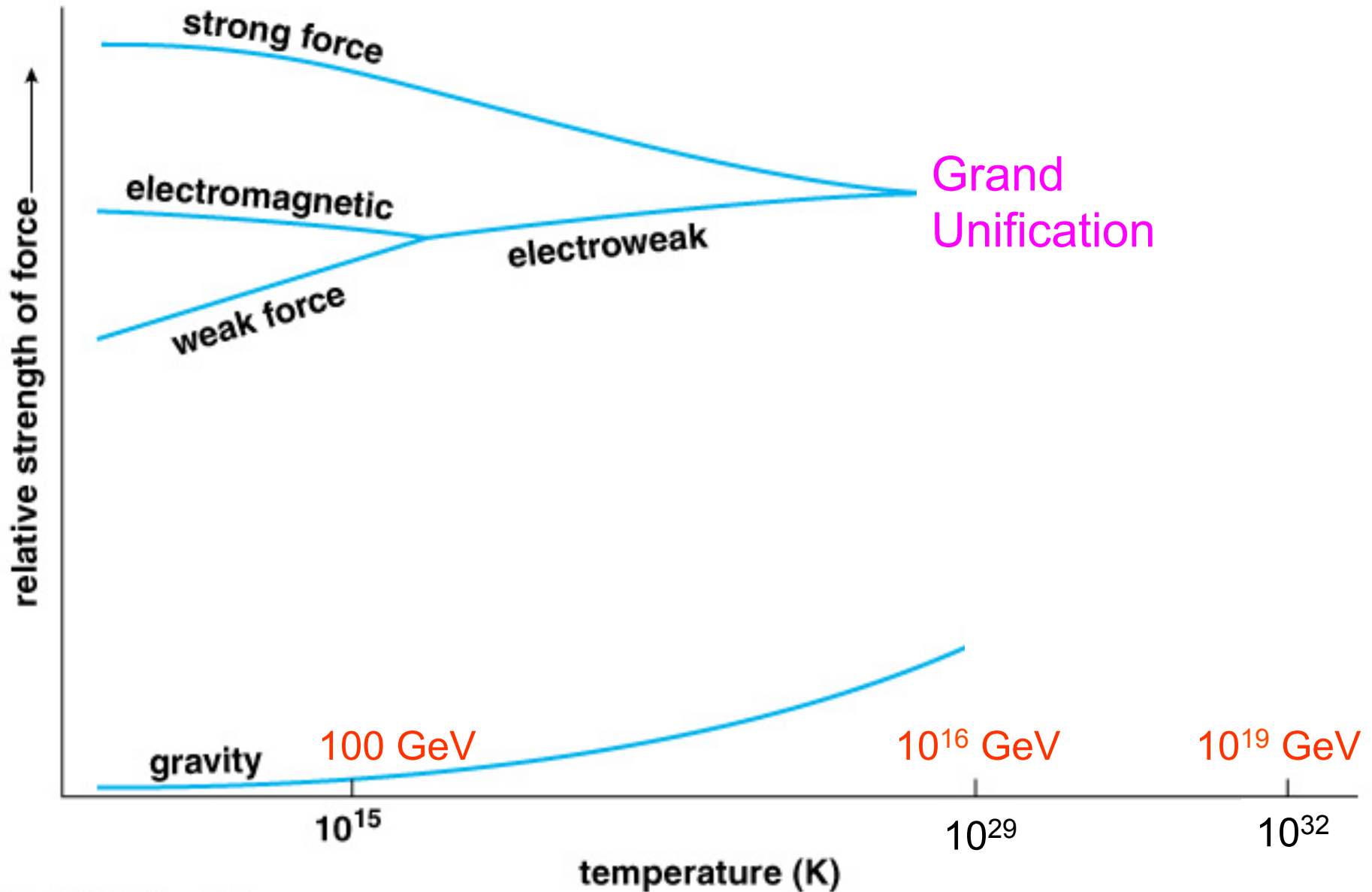

Copyright © Addison Wesley.

Unification of Forces

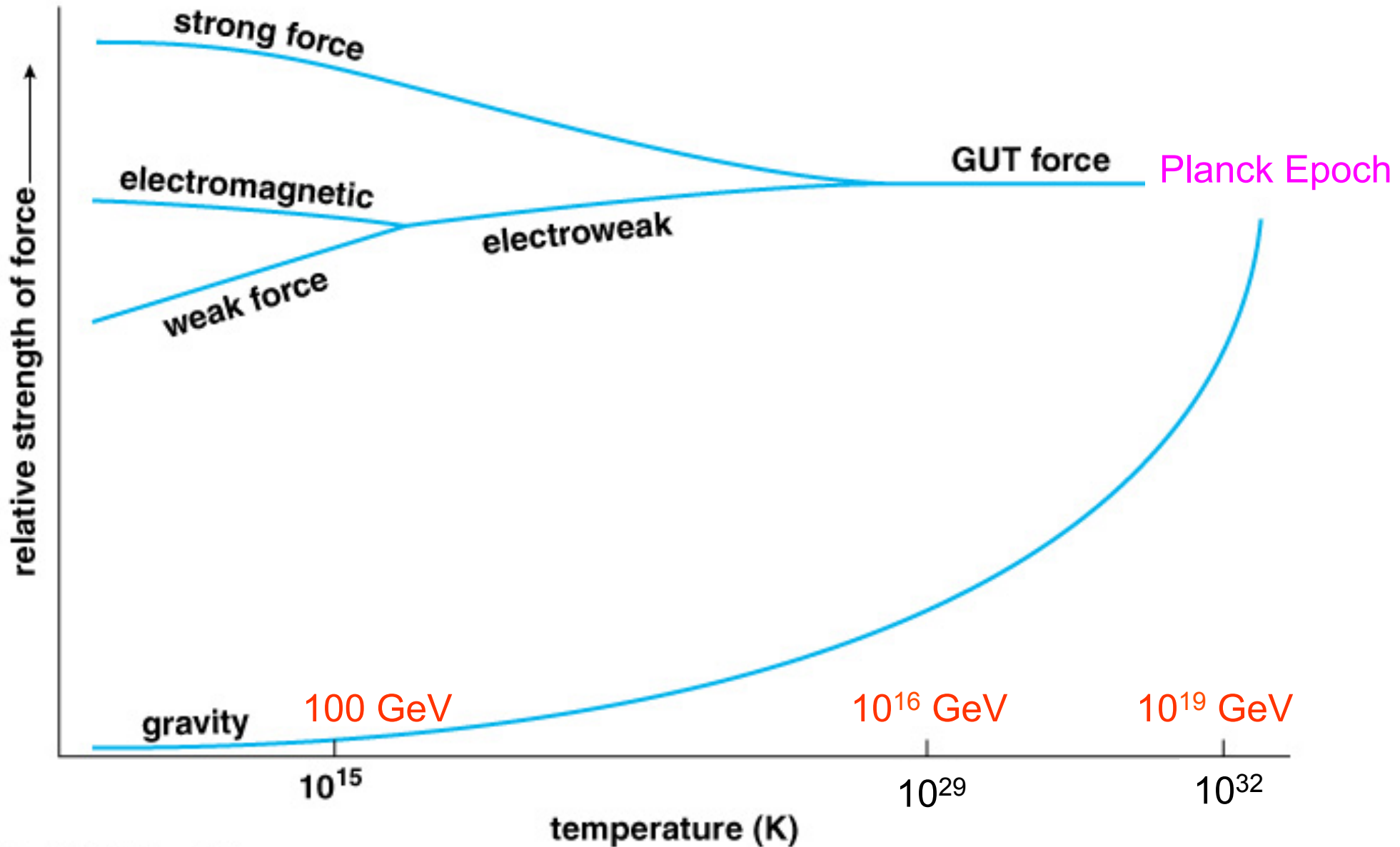

Copyright © Addison Wesley.

Structure of DNA

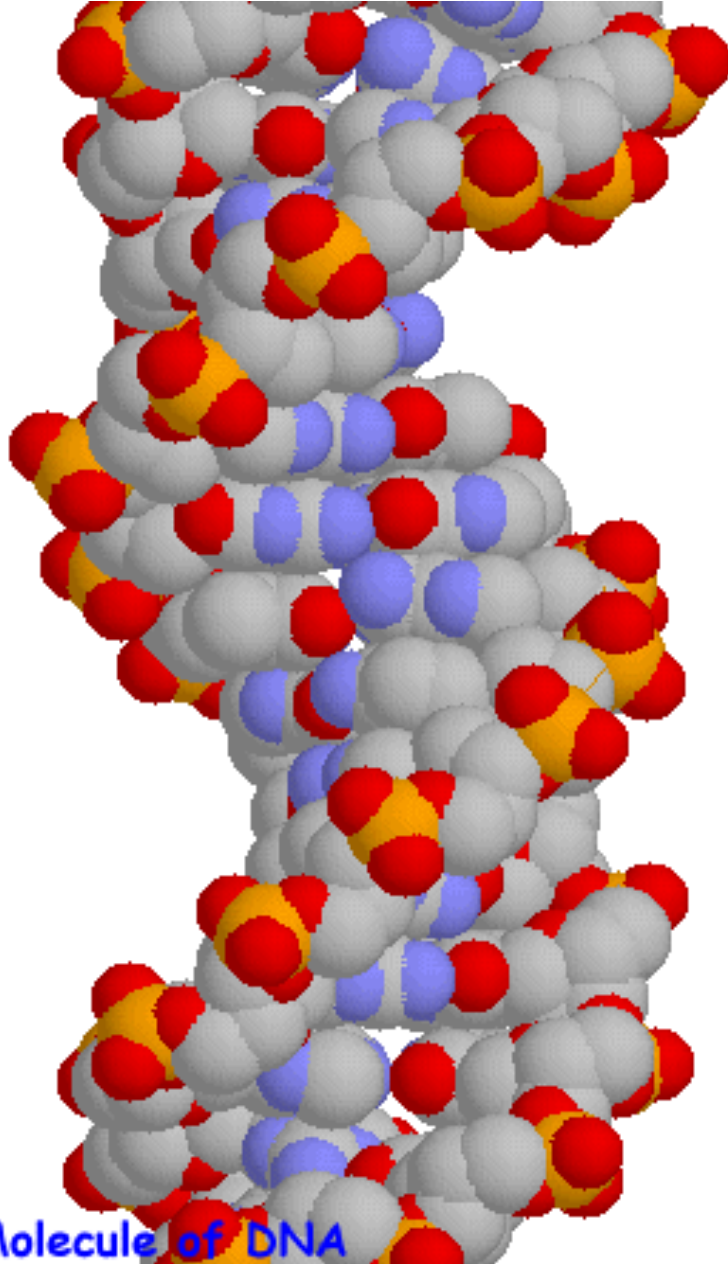

©Rothamsted Experimental Station, 1997, 1998

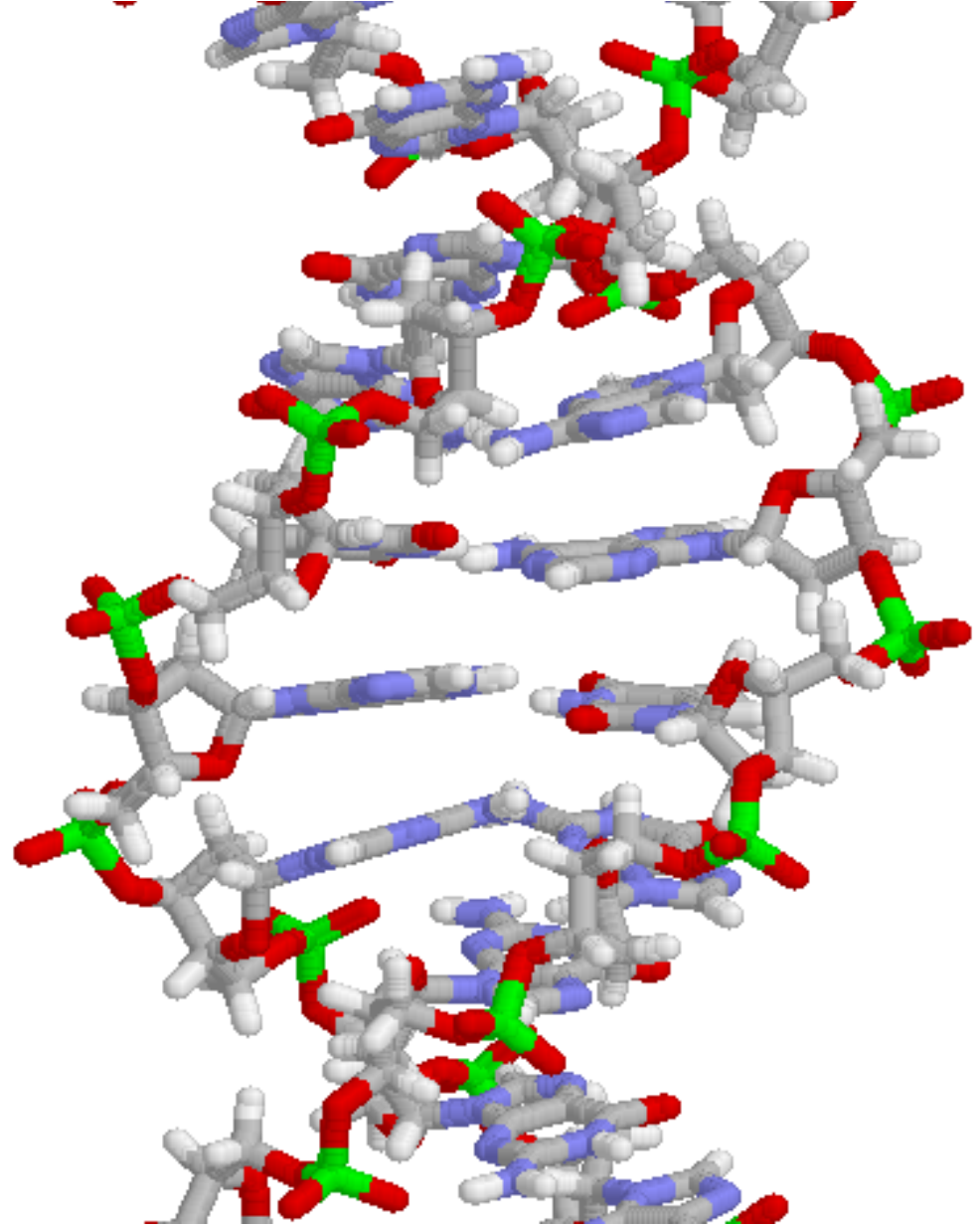

Molecule of DNA

3 billion base pairs

Symmetry Breaking

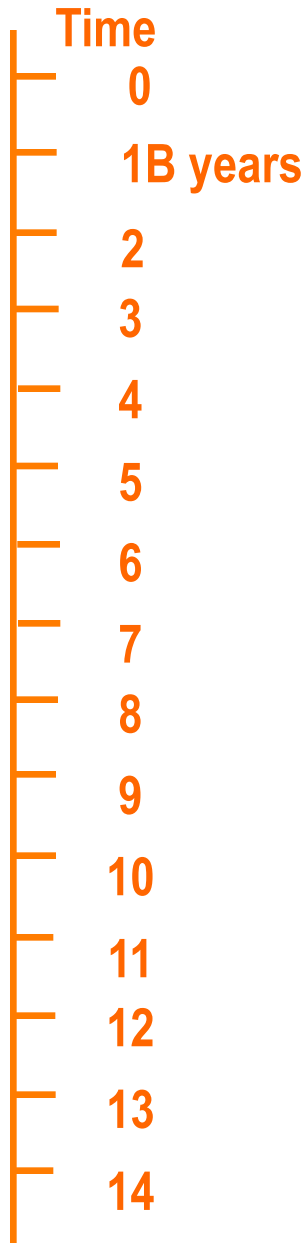

Simple

*Symmetry
Break Down*

Complex

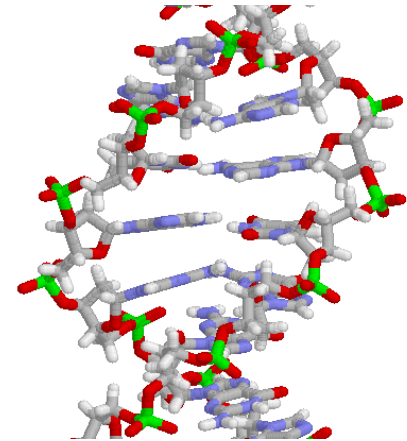
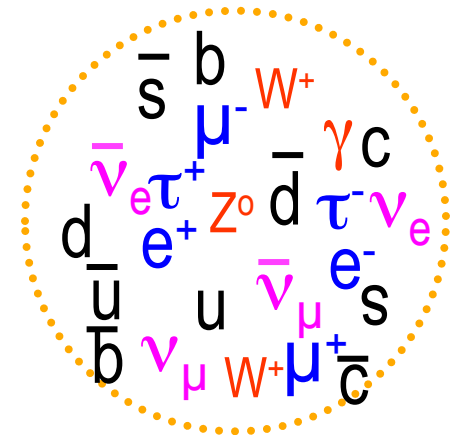

The Beginning

- Everything was the same \leftrightarrow Perfect symmetry.
 - All the particles are the same as photons.
 - All four forces are the same.
- The Universe was 10 dimension.

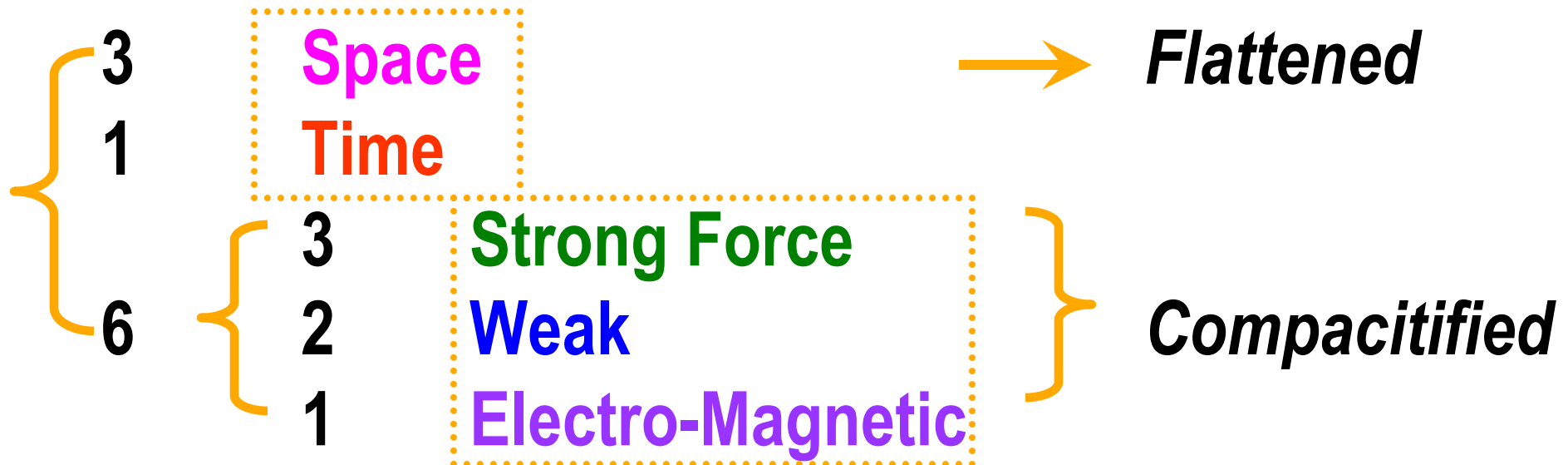

Seven Phases of Cosmic Evolution

Spontaneous Symmetry Breaking

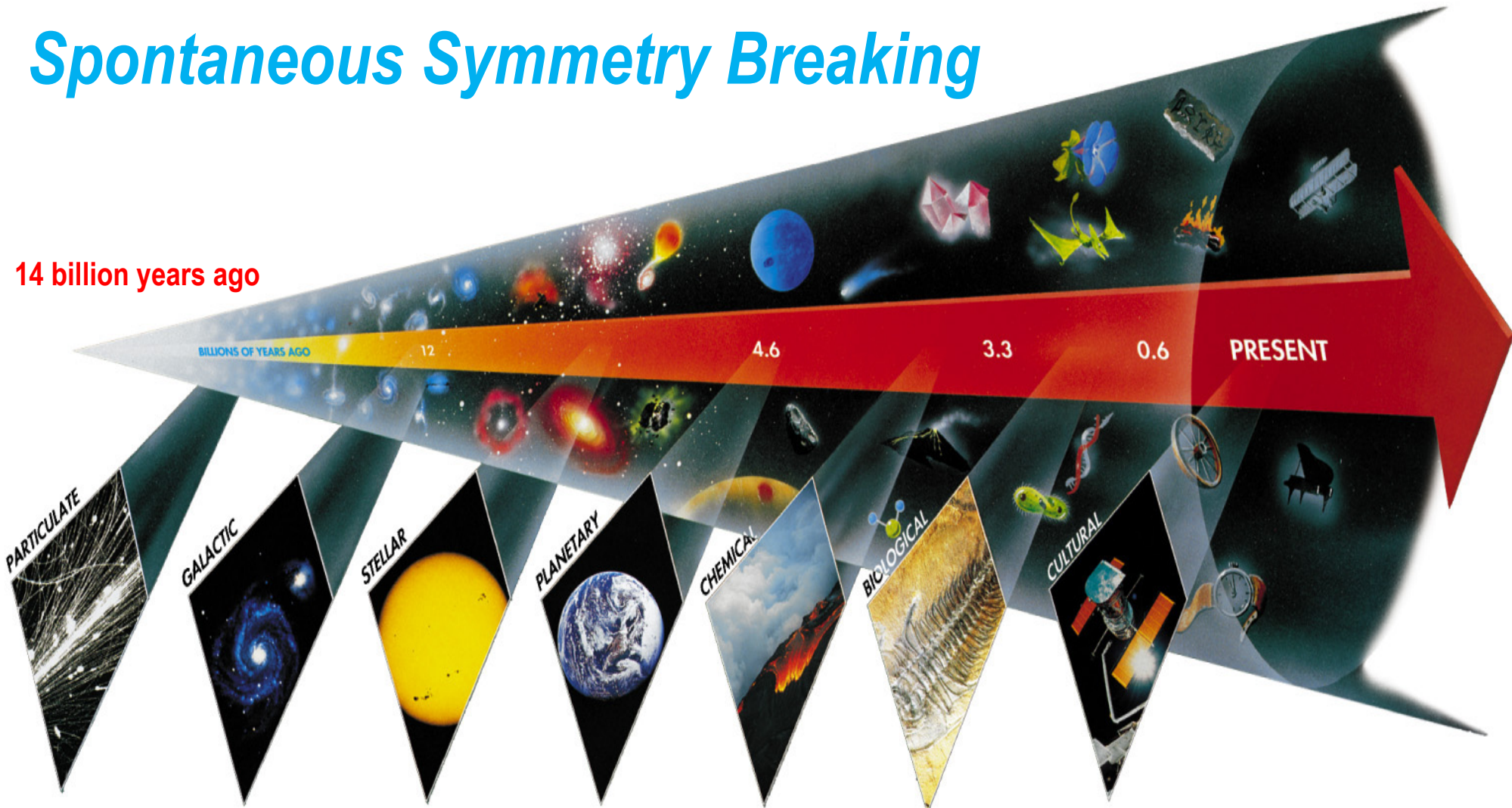

Origin of
Particles

CERN and LHC in Geneva

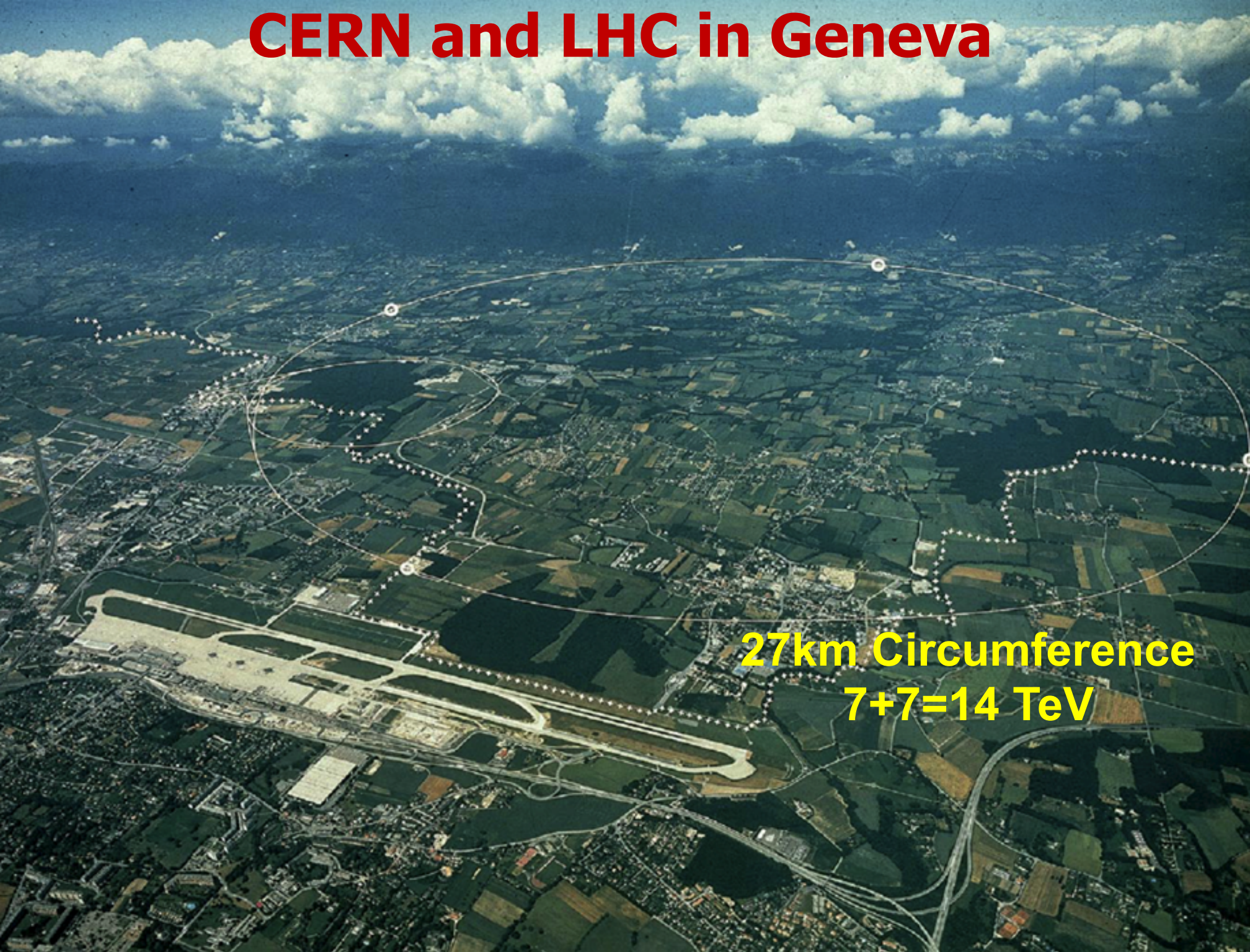

27km Circumference
7+7=14 TeV

LHC Tunnel with Magnets



CMS Collaboration (1993 ~)

(144 Institutions with about 1700 scientists)



ARMENIA

- Yerevan Physics Inst., Yerevan



AUSTRIA

- HEPHY, Wien



BELARUS

- Institute of Nuclear Problems, Minsk
- National Centre of Part. and HEP, Minsk
- Res. Inst. of Applied Physical Probl., Minsk
- Byelorussian State Univ., Minsk



BELGIUM

- Univ. Instelling Antwerpen, Wilrijk
- Univ. Libre de Bruxelles, Brussels
- Vrije Universiteit Brussel, Brussels
- Univ. Catholique de Louvain, Louvain-la-Neuve
- Univ. de Mons-Hainaut, Mons



BULGARIA

- Inst. for Nucl. Res. and Nucl. Energy, Sofia
- Univ. of Sofia, Sofia



CHINA, PR

- Inst. of High Energy Physics, Beijing
- Peking Univ., Beijing
- Univ. for Science & Tech. of China, Hefei, Anhui



CROATIA

- Tech. Univ. of Split, Split
- Univ. of Split, Split



CYPRUS

- Univ. of Cyprus, Nicosia



ESTONIA

- Inst. of Chemical Phys. and Biophys., Tallinn



FINLAND

- Helsinki Institute of Physics, Helsinki
- Dpt of Phys., Univ. of Helsinki, Helsinki
- Univ. of Jyväskylä, Jyväskylä
- Helsinki University of Technology, Helsinki
- Univ. of Oulu, Oulu
- Tampere Univ. of Tech., Tampere



FRANCE

- LAPP, IN2P3-CNRS, Annecy-le-Vieux
- IPN, IN2P3-CNRS, Univ. Lyon I, Villeurbanne
- LPNHE, Ecole Polytech., IN2P3-CNRS, Palaiseau
- DSM/DAPNIA, CEA/Saclay, Gif-sur-Yvette
- IRES, IN2P3-CNRS - ULP, UHA, LEPSI, Strasbourg



GEORGIA

- High Energy Phys. Inst., Tbilisi State Univ., Tbilisi
- Inst. of Physics Academy of Science, Tbilisi



GERMANY

- RWTH, I. Physik. Inst., Aachen
- RWTH, III. Physik. Inst. A, Aachen
- RWTH, III. Physik. Inst. B, Aachen
- Humboldt-Univ. zu Berlin, Berlin
- Inst. für Exp. Kernphysik, Karlsruhe



GREECE

- Univ. of Athens, Athens
- Inst. of Nucl. Phys. "Demokritos", Attiki
- Univ. of Ioánnina, Ioánnina



HUNGARY

- KFKI Res. Inst. for Part. & Nucl. Phys., Budapest
- Kossuth Lajos Univ., Debrecen
- Institute of Nuclear Research ATOMKI, Debrecen



INDIA

- Panjab Univ., Chandigarh
- Bhabha Atomic Res. Centre, Mumbai
- Univ. of Delhi South Campus, New Delhi
- TIFR - EHEP, Mumbai
- TIFR - HECR, Mumbai



ITALY

- Univ. di Bari e Sez. dell' INFN, Bari
- Univ. di Bologna e Sez. dell' INFN, Bologna
- Univ. di Catania e Sez. dell' INFN, Catania
- Univ. di Firenze e Sez. dell' INFN, Firenze
- Univ. di Genova e Sez. dell' INFN, Genova
- Univ. di Padova e Sez. dell' INFN, Padova
- Univ. di Pavia e Sez. dell' INFN, Pavia
- Univ. di Perugia e Sez. dell' INFN, Perugia
- Univ. di Pisa e Sez. dell' INFN, Pisa
- Univ. di Roma I e Sez. dell' INFN, Roma
- Univ. di Torino e Sez. dell' INFN, Torino



KOREA

- Cheju National University, Cheju
- Chonnam National University, Kwangju
- Choongbuk National University, Chongju
- Dongshin University, Naju
- Kangnung National University, Kangnung
- Kwangwon National University, Chunchon
- Kon-Kuk University, Seoul
- Korea University, Seoul
- Kyungpook National University, Taegu
- Pohang University of Science and Technology, Pohang
- Gyeongsang National University, Jinju
- Seonam University, Namwon
- Seoul National Univ. of Education, Seoul
- Wonkwang University, Iri



PAKISTAN

- Quaid-I-Azam Univ., Islamabad
- Ghulam Ishaq Khan Institute, Swabi



POLAND

- Inst. of Exp. Phys., Warsaw
- Soltan Inst. for Nucl. Studies, Warsaw



PORTUGAL

- LIP, Lisboa



RUSSIA

- JINR, Dubna
- Inst. for Nucl. Res., Moscow
- Inst. for Theoretical and Exp. Phys., Moscow
- P.N. Lebedev Phys. Inst., Moscow
- Moscow State Univ., Moscow
- Budker Inst. for Nucl. Phys., Novosibirsk
- Inst. for High Energy Phys., Protvino
- Petersburg Nucl. Phys. Inst., Gatchina (St Petersburg)



SLOVAK REPUBLIC

- Slovak University of Technology, Bratislava



SPAIN

- CIEMAT, Madrid
- Univ. Autónoma de Madrid, Madrid
- Univ. de Oviedo, Oviedo
- IFCA, CSIC-Univ. de Cantabria, Santander



SWITZERLAND

- Univ. Basel, Basel
- CERN, Geneva
- Paul Scherrer Inst., Villigen
- Inst. für Teilchenphysik, ETH, Zürich
- Univ. Zürich, Zürich



TURKEY

- Cukurova Univ., Adana
- Middle East Technical Univ., Ankara



UKRAINE

- Inst. of Single Crystals of Nat. Acad. of Science, Kharkov
- Kharkov Inst. of Phys. and Tech., Kharkov
- Kharkov State Univ., Kharkov



UNITED KINGDOM

- Univ. of Bristol, Bristol
- Brunel Univ., Uxbridge
- Imperial College, Univ. of London, London
- RAL, Didcot



USA

- Univ. of Alabama, Tuscaloosa
- Iowa State Univ., Ames
- Boston Univ., Boston
- California Inst. of Tech., Pasadena
- Carnegie Mellon Univ., Pittsburgh
- Univ. of Illinois at Chicago, Chicago
- Fairfield Univ., Fairfield
- Fermi National Accelerator Lab., Batavia
- Florida State Univ. - HEPG, Tallahassee
- Florida State Univ. - SCRI, Tallahassee
- Univ. of Florida, Gainesville
- The Univ. of Iowa, Iowa City
- Johns Hopkins Univ., Baltimore
- LLNL, Livermore
- Los Alamos Nat. Lab., Los Alamos
- Univ. of Maryland, College Park
- Univ. of Minnesota, Minneapolis
- Univ. of Mississippi, Oxford
- Massachusetts Inst. of Tech., Cambridge
- Univ. of Nebraska-Lincoln, Lincoln
- Northeastern Univ., Boston
- Northwestern Univ., Evanston
- Univ. of Notre Dame, Notre Dame
- The Ohio State Univ., Columbus
- Princeton Univ., Princeton
- Purdue Univ., West Lafayette
- Rice Univ., Houston
- Univ. of California, Riverside
- Univ. of Rochester, Rochester
- Rutgers, the State Univ. of New Jersey, Piscataway
- Texas Tech Univ., Lubbock
- Univ. of Texas at Dallas, Richardson
- Univ. of California at Davis, Davis
- UCLA, Los Angeles
- Univ. of California San Diego, La Jolla
- Virginia Polytech. Inst. and State Univ., Blacksburg
- Univ. of Wisconsin, Madison



UZBEKISTAN

- Inst. of Nucl. Phys. of the Uzbekistan Acad. of Sciences, Tashkent

electromagnetic calorimeter

solenoid

muon chambers

hadronic calorimeter

inner tracker

magnet yoke

CMS

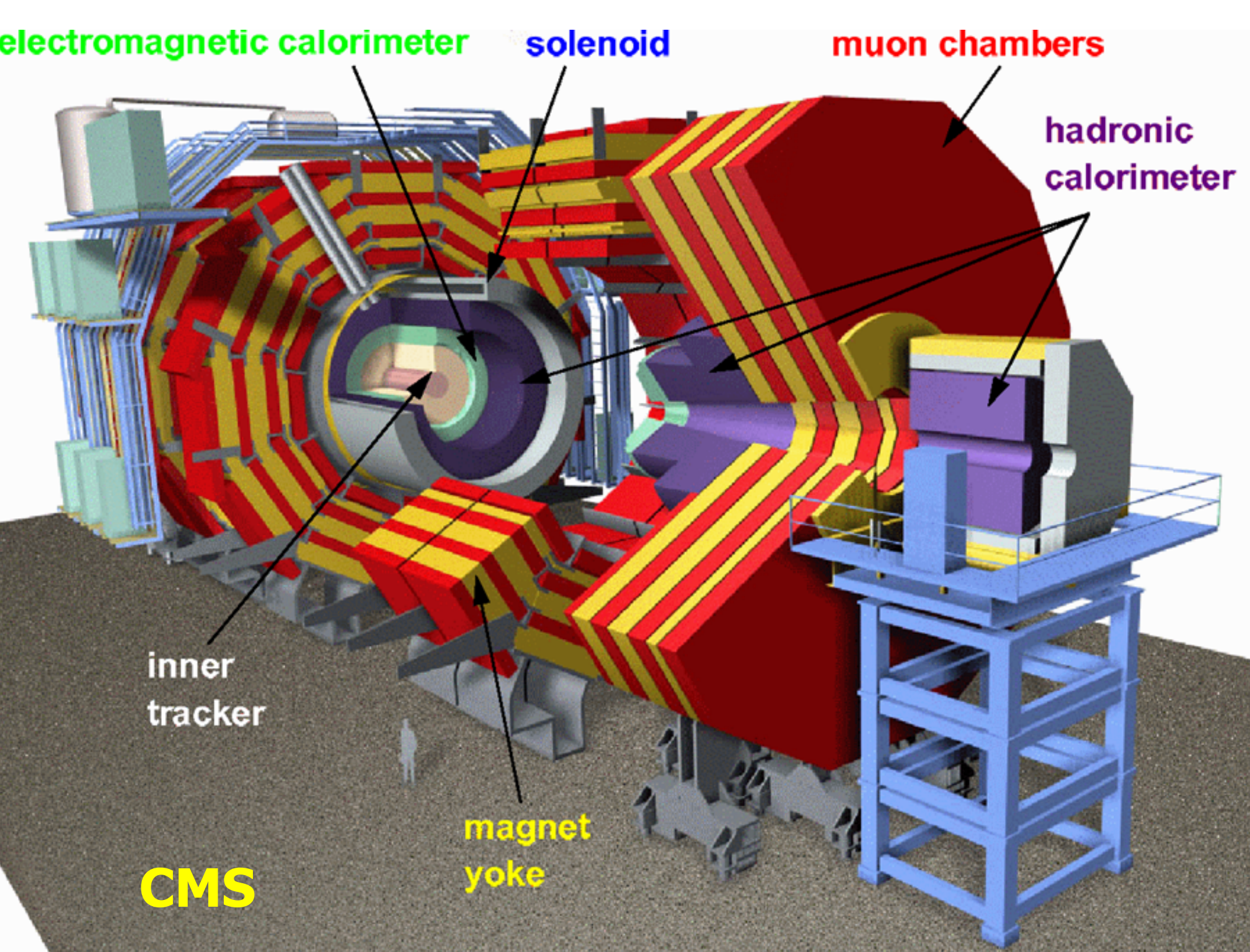

CMS Barrel Yoke



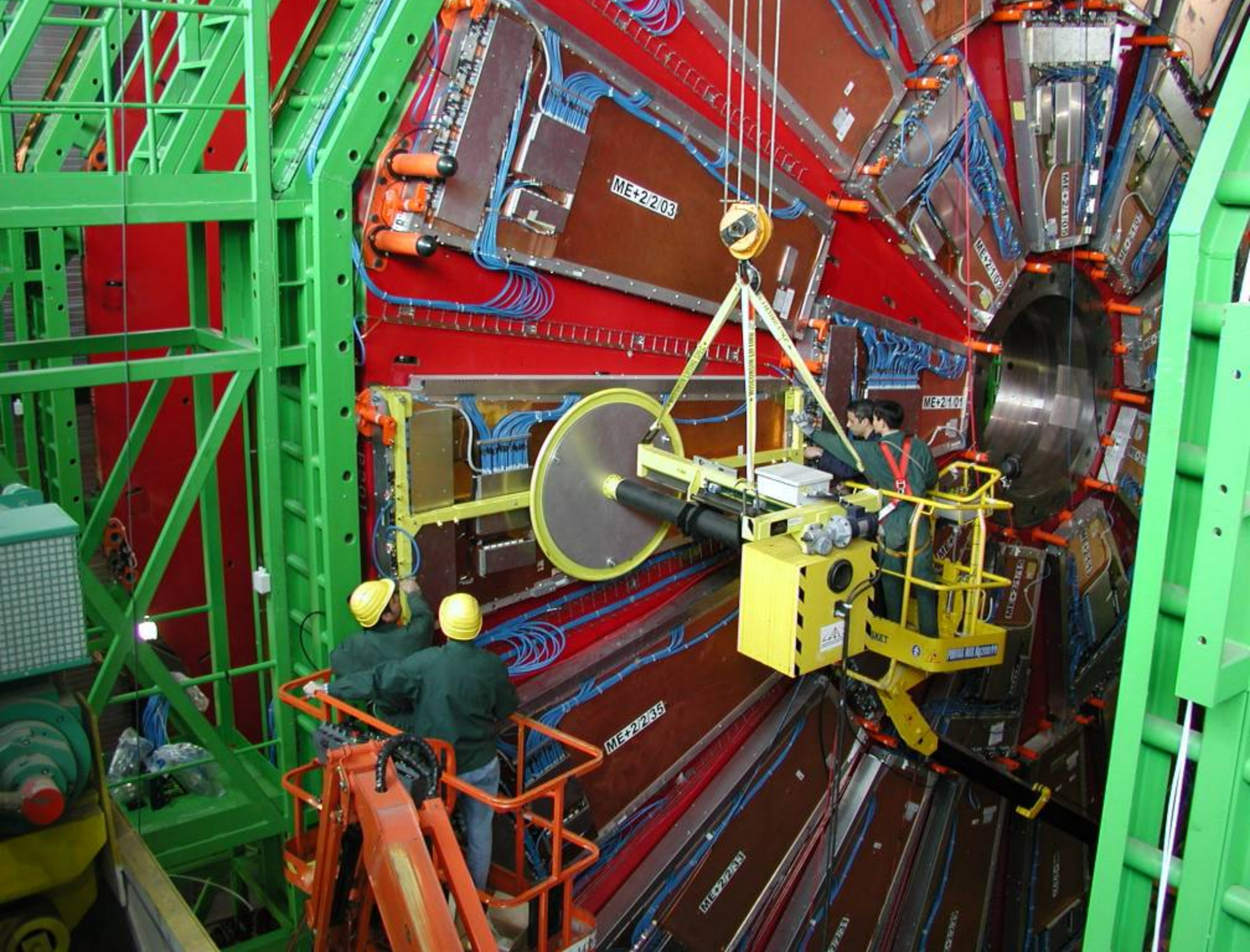

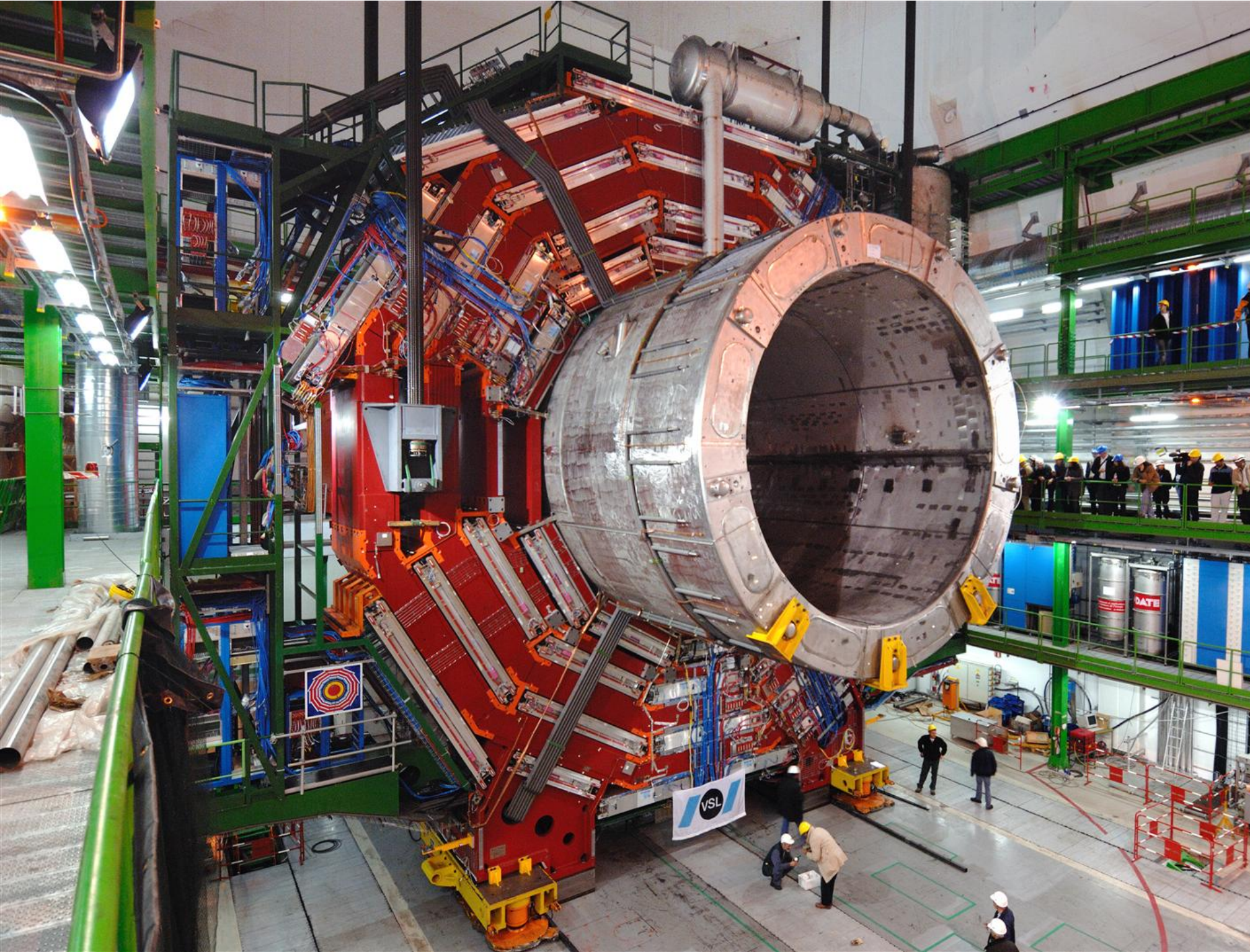

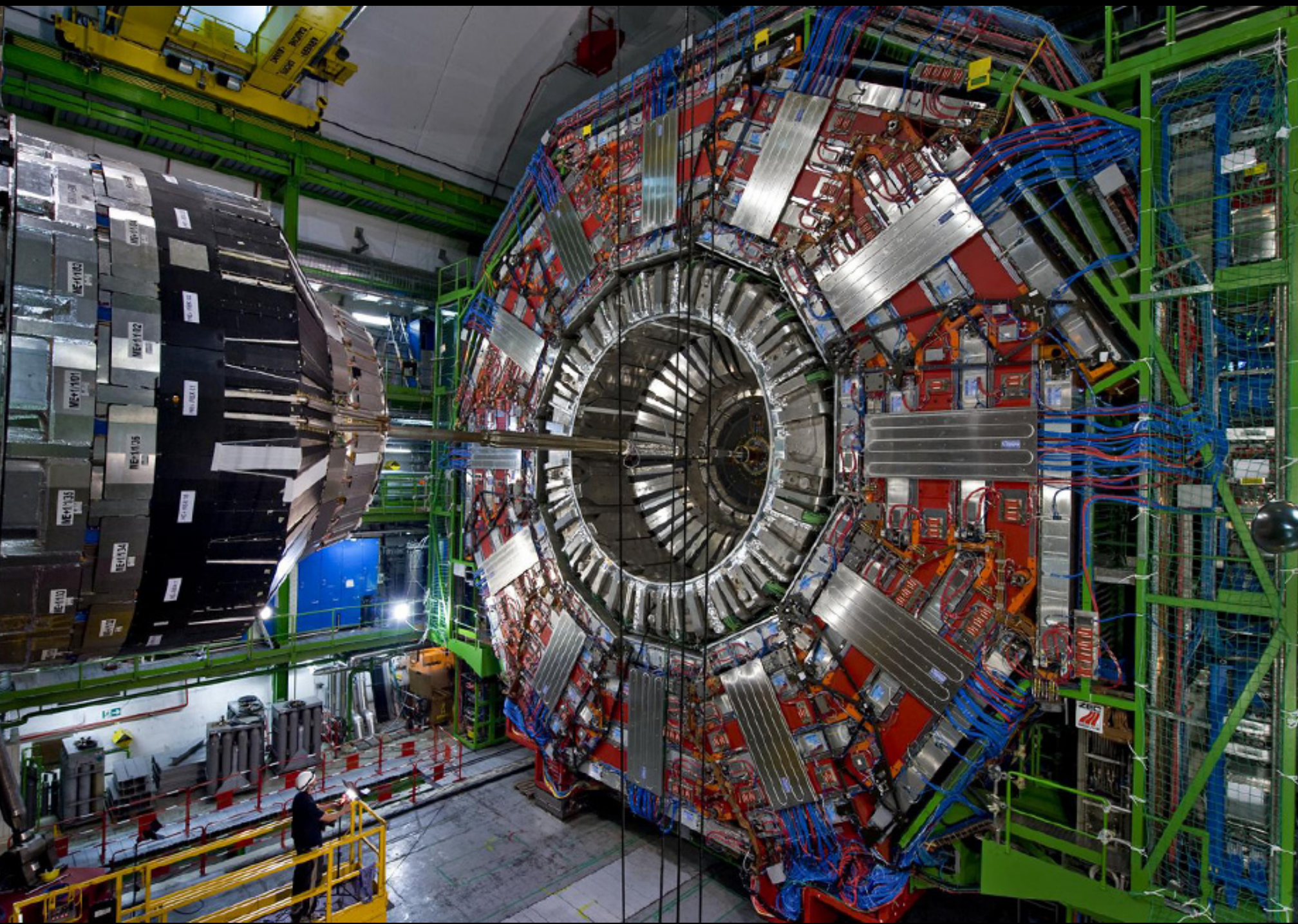

Newsweek

The Biggest Experiment Ever (And It's European)



Particle detectors constructed at Westwood, now at LHC, CERN



The new CERN collider in Geneva

PHOTOGRAPH BY MARTIAL TREZZINI-AP

SEPTEMBER 15, 2008

newsweek.com



Albania	Lek 600	Finland	€4.40	Israel	NIS 20.00	Netherlands	€4.40	Slovenia	€3.40
Austria	€4.40	France	€4.40	Italy	€4.40	Norway	Kr 41.00	Spain	€4.40
Belgium	€4.40	Germany	€4.40	Kazakhstan	\$4.40	Poland (incl tax)	PLN 12.30	Sweden	SKr 34.00
Bulgaria	BGL 4.50	Gibraltar	€2.90	Latvia	€4.40	Portugal Cont	€4.40	Switzerland	SF 7.70
Croatia	KN 22.00	Greece	€4.40	Lithuania	\$4.40	Romania	Lei 11.00	Turkey	YTL 4.00
Cyprus	€2.58/€4.40	Hungary	FL 700.00	Luxembourg	€4.40	Russia	€4.40	Ukraine	€4.40
Czech Republic	Czk 115.00	Iceland	IKR 390.00	Malta	Lm 1.70/€3.96	Serbia	DIN 240	United Kingdom	£2.80
Denmark	Kr 38.00	Ireland (incl tax)	€4.40	Montenegro	DIN 240	Slovakia	SK 120.00/€3.98	U.S. Forces	\$3.25

11/27/2012

Sept 15, 2008 Issue

CMS Experiment, CERN

Data_taken 2009-11-07 19:12:36.880368 GMT

Run_no 120015

Event_no 8

Lumi_sec 1

Orbit 584946

Crossing 2603

<http://iguana.cern.ch/isy/>

L1 Triggers:

L1_DoubleHEBitCountsRing1_P1N1

L1_DoubleHEBitCountsRing2_P1N1

L1_ETM20

L1_ETM30

L1_MinBias_HTT10

L1_Mu3QE8_Jet6

L1_SingleEG1

L1_SingleEG10

L1_SingleEG12

L1_SingleEG15

L1_SingleEG20

L1_SingleEG25

L1_SingleEG30

L1_SingleEG35

L1_SingleHEBitCountsRing1_1

L1_SingleHEBitCountsRing2_1

L1_SingleJet10

L1_SingleJet15Jet30

L1_SingleJet20

L1_SingleJet30

L1_SingleJet6

L1_SingleMu

L1_SingleMu5

L1_SingleMuBeam10

L1_SingleMuBeam5

L1_SingleMuBeam10

L1_SingleMuBeam20

L1_SingleMuBeam30

First Event at LHC – Recreation of the Big Bang! (Nov 7, 2009)

News release on July 4th !

Physicists Find Elusive Particle Seen as Key to Universe



Pool photo by Denis Balibouse

Scientists in Geneva on Wednesday applauded the discovery of a subatomic particle that looks like the Higgs boson.

By DENNIS OVERBYE

Published: July 4, 2012 |  122 Comments

Higgs particle \rightarrow 2 gamma rays



CMS Experiment at the LHC, CERN
Data recorded: 2012-May-13 20:08:14.621490 GMT
Run/Event: 194108 / 564224000

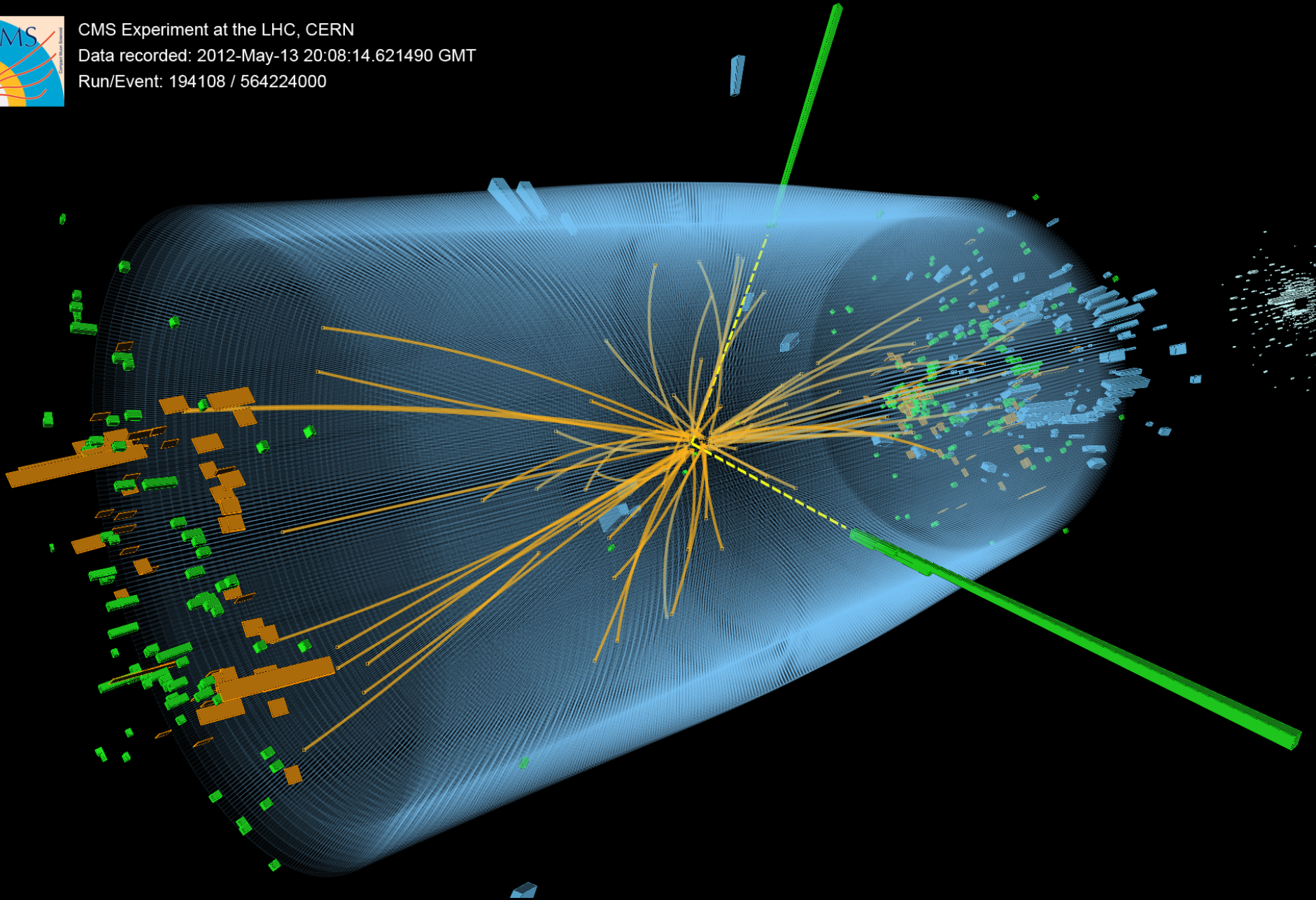

Seven Phases of Cosmic Evolution

Spontaneous Symmetry Breaking

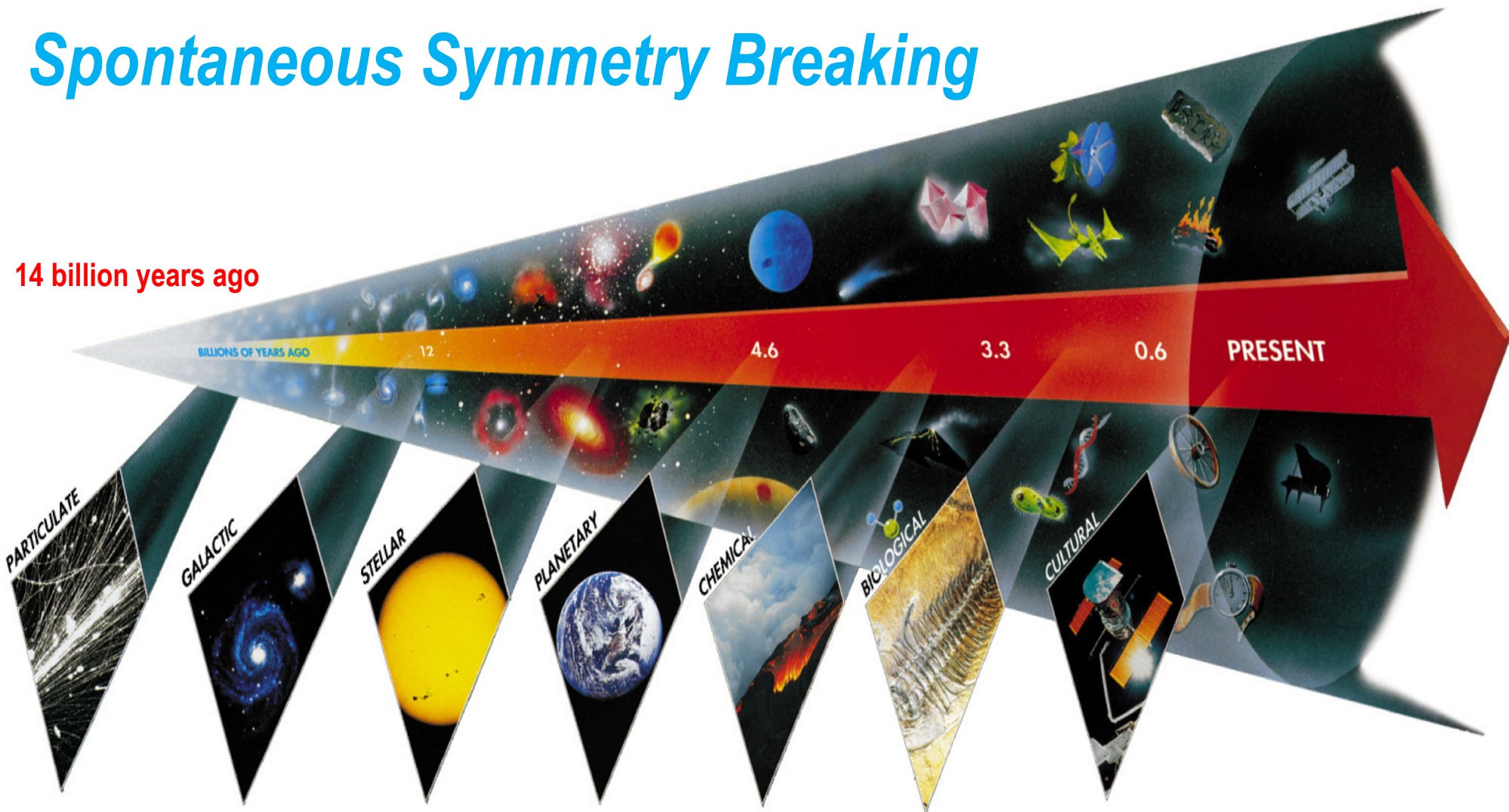

Origin of
Particles

Origin of
Structure



Dark Matter is required!

ANDROMEDA
GALAXY.

Formation of Structure in the Universe

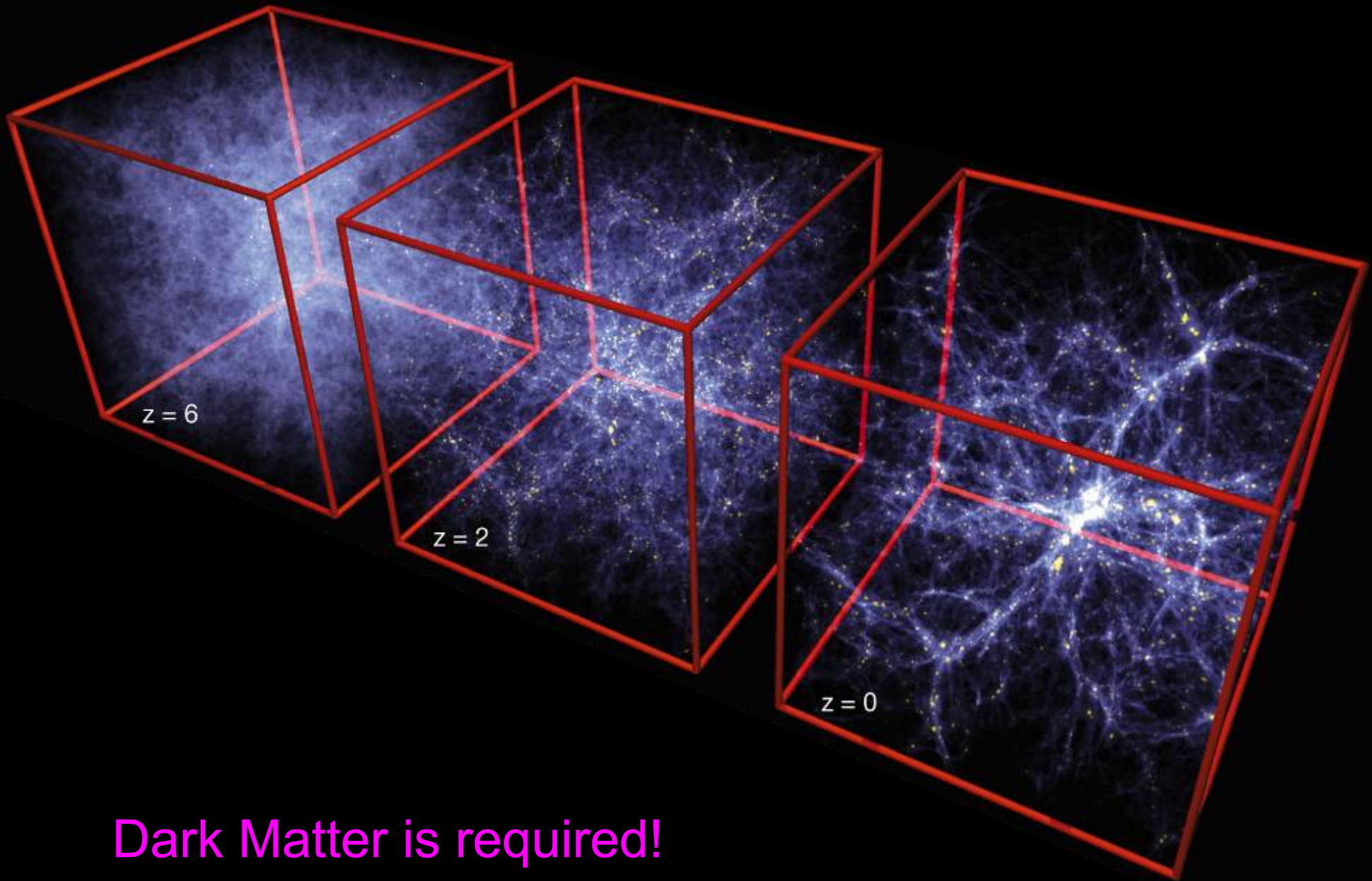

Dark Matter is required!

Cosmic Pie Chart

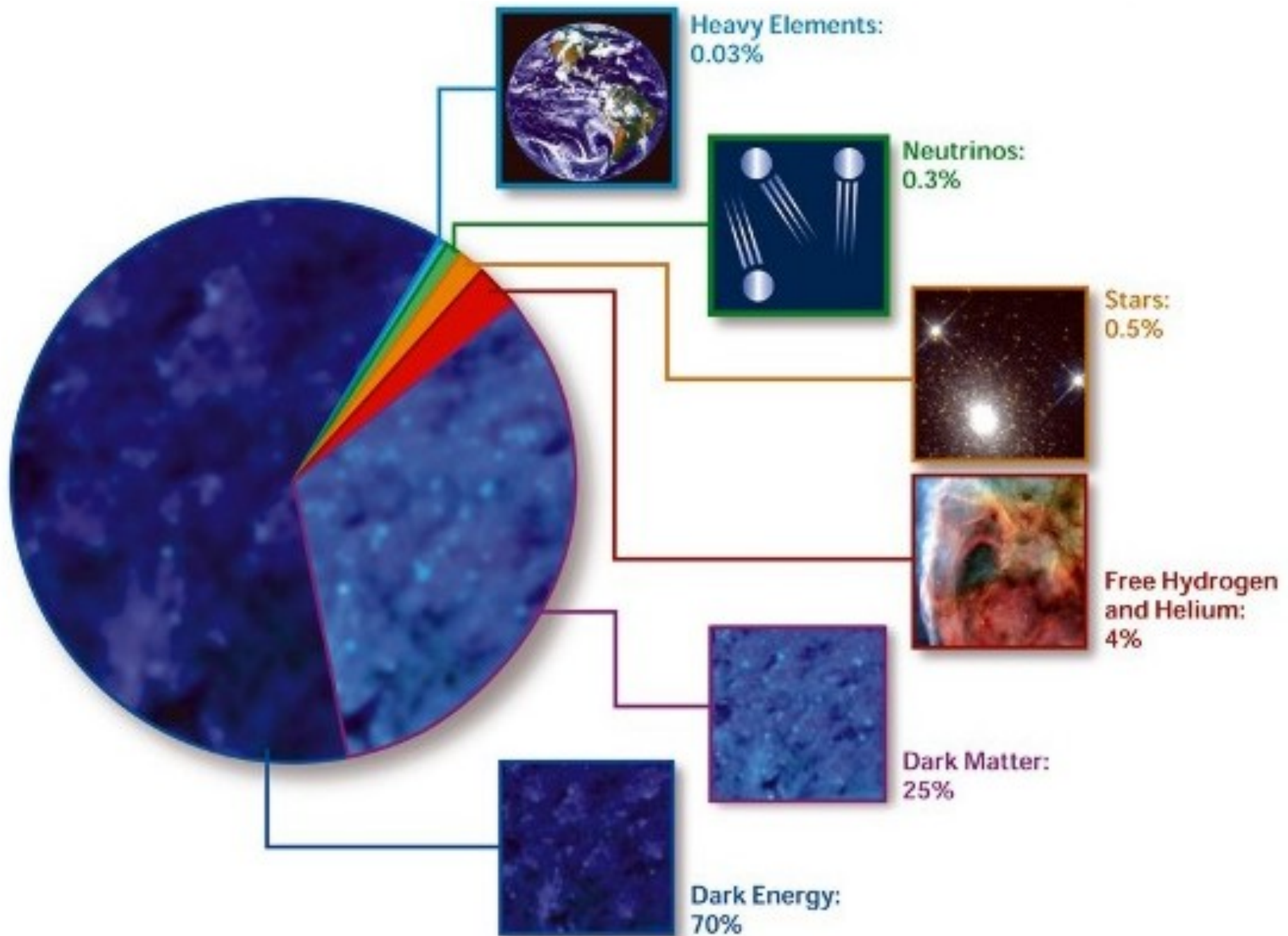

Laboratori Nazionali del Gran Sasso, Italy

LNGS 1400 m Rock (3100 w.m.e)



XENON100 Detector

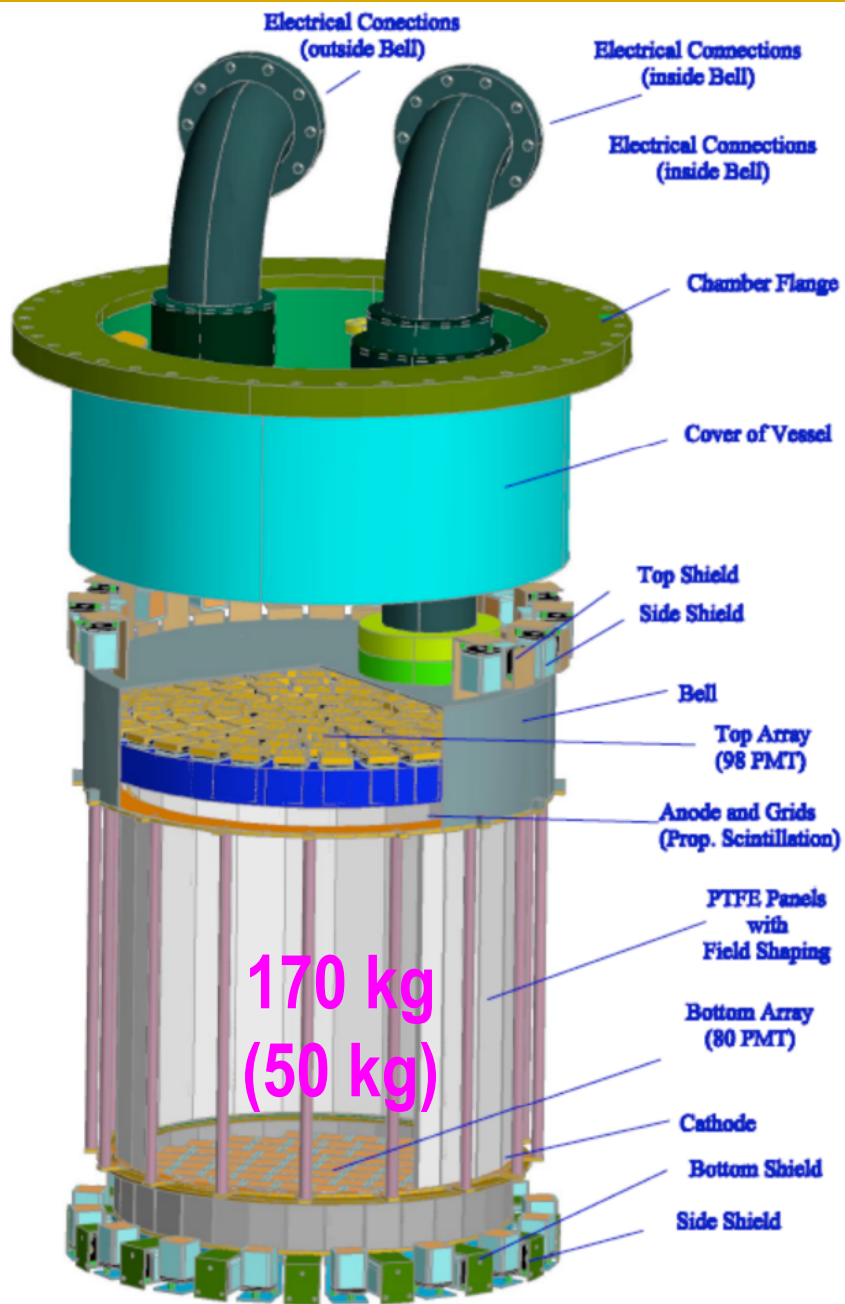

XENON100 Detector (2009)



XENON 1T at Gran Sasso

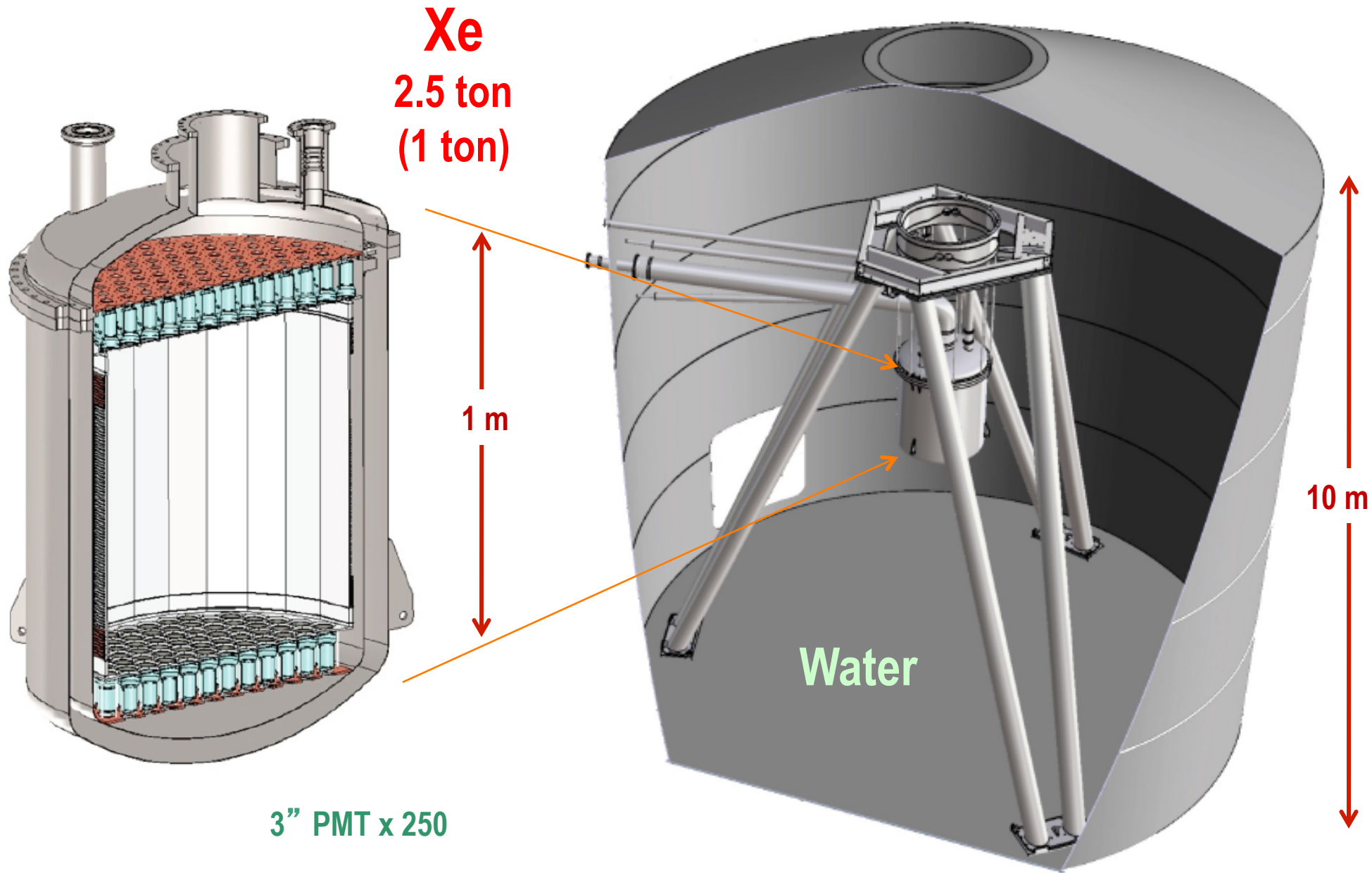

Seven Phases of Cosmic Evolution

Spontaneous Symmetry Breaking

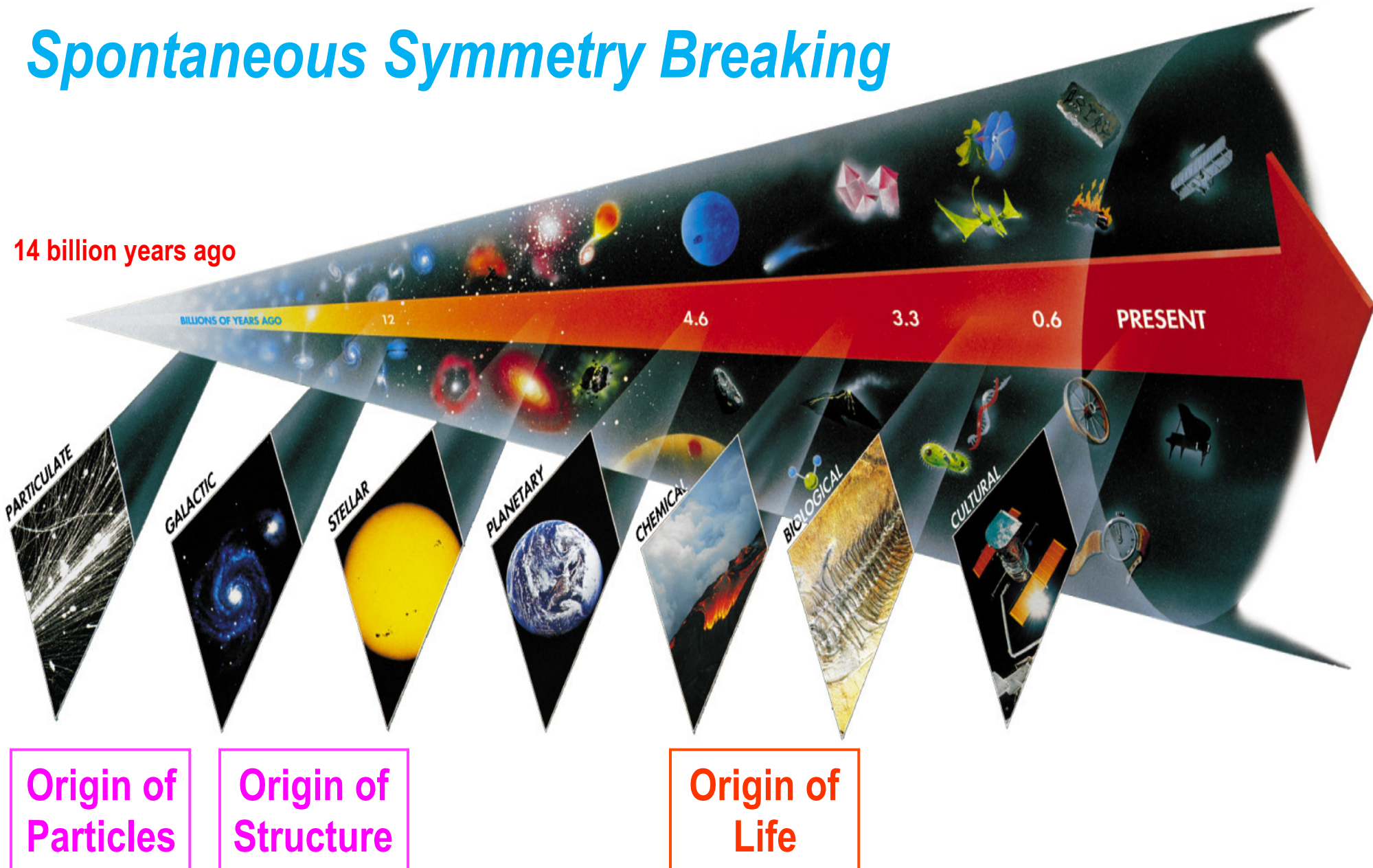

Organic Polymers (4.5B → 4B years)

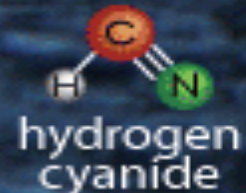
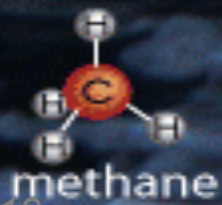
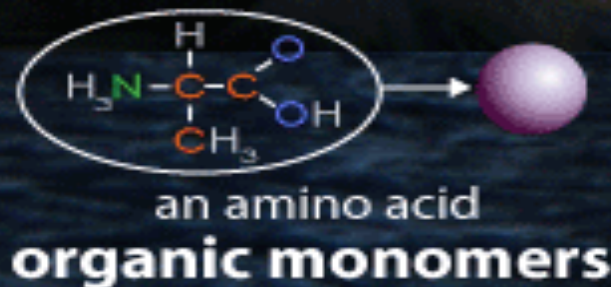
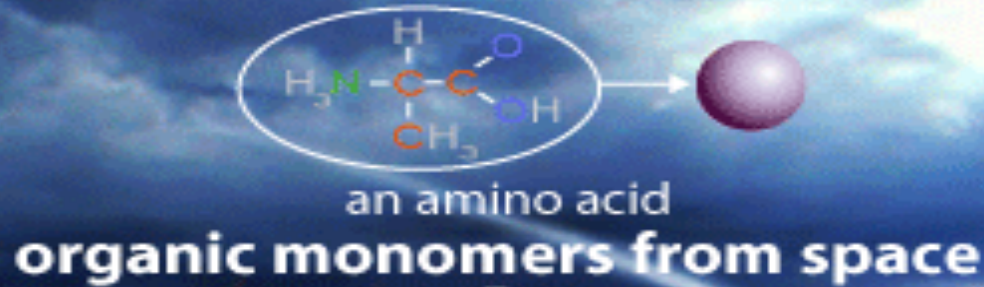

inorganic molecules from Earth

RNA World (4B → 3.5B years ago)

1. Organic precursor molecules appear.

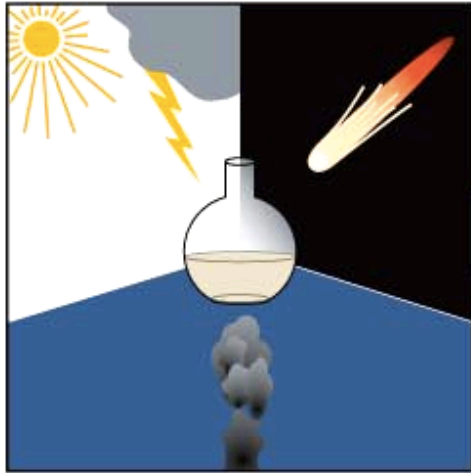

2. RNA molecules become self-replicating.

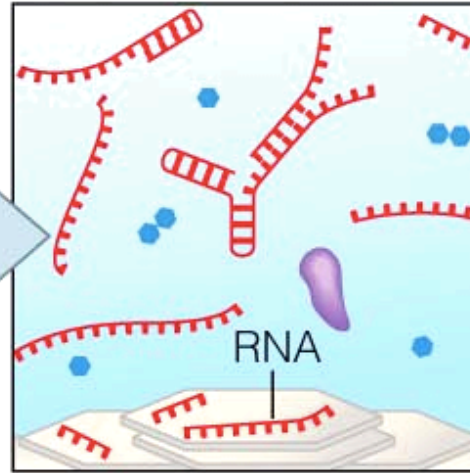

3. Membrane-enclosed pre-cells arise.

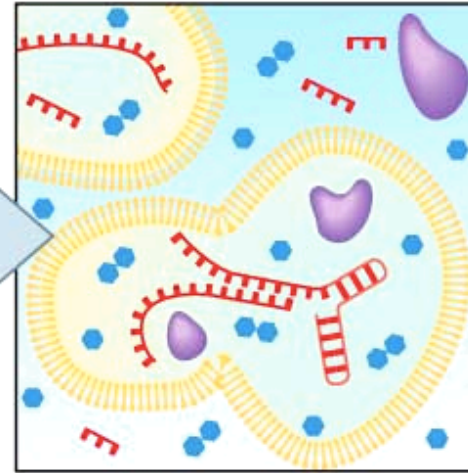

Copyright © 2007 Pearson Education, Inc., publishing as Pearson

4. True cells with RNA genome appear.

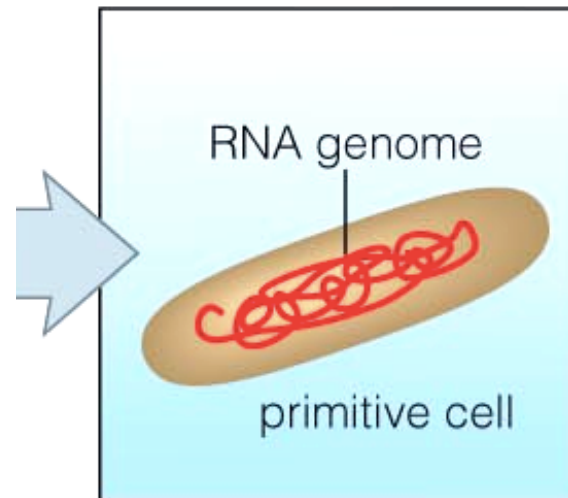

5. Modern cells with DNA genome evolve.

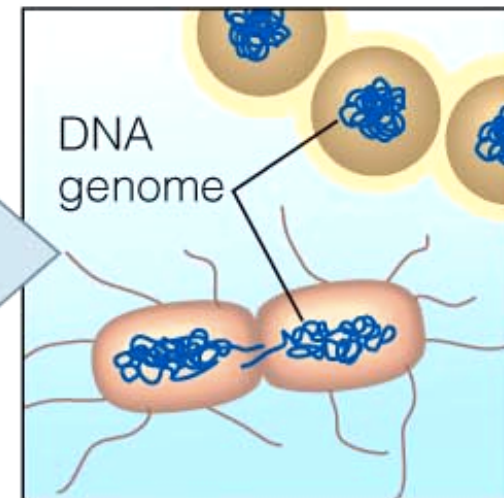

Eukaryote (~2B years ago)

Symmetry breaking

Cell made by proteins



Gene made by DNA

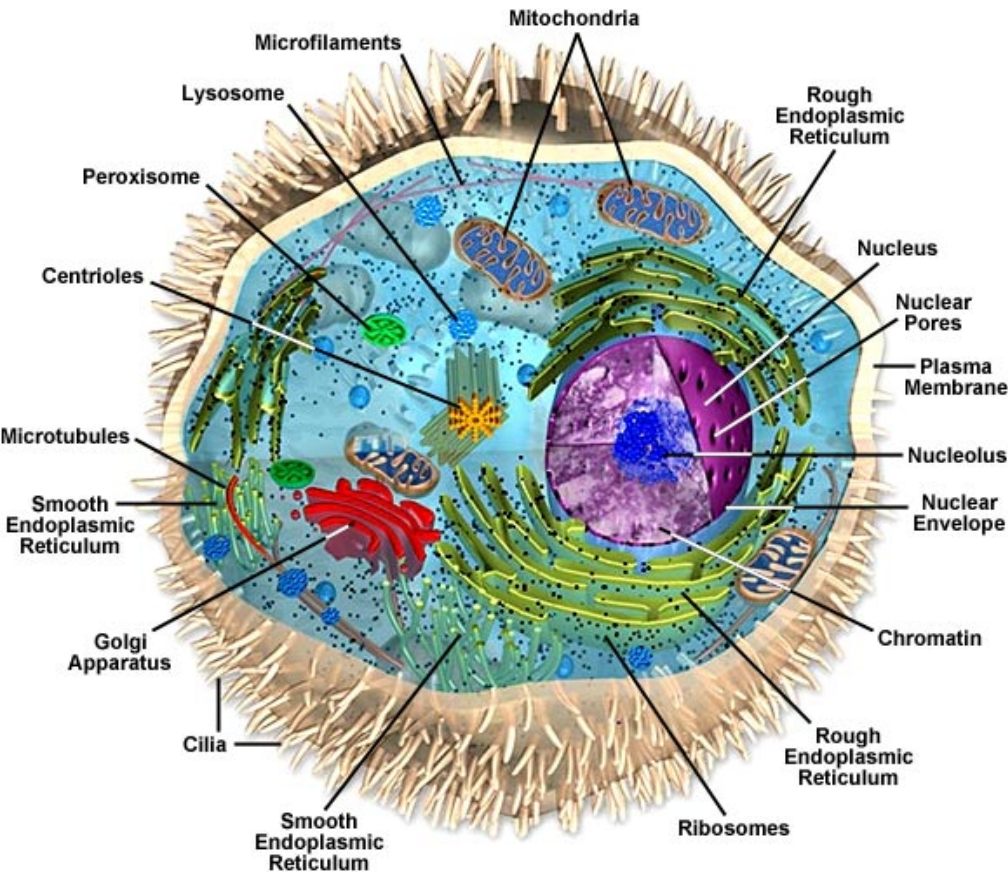

10 – 50 μm

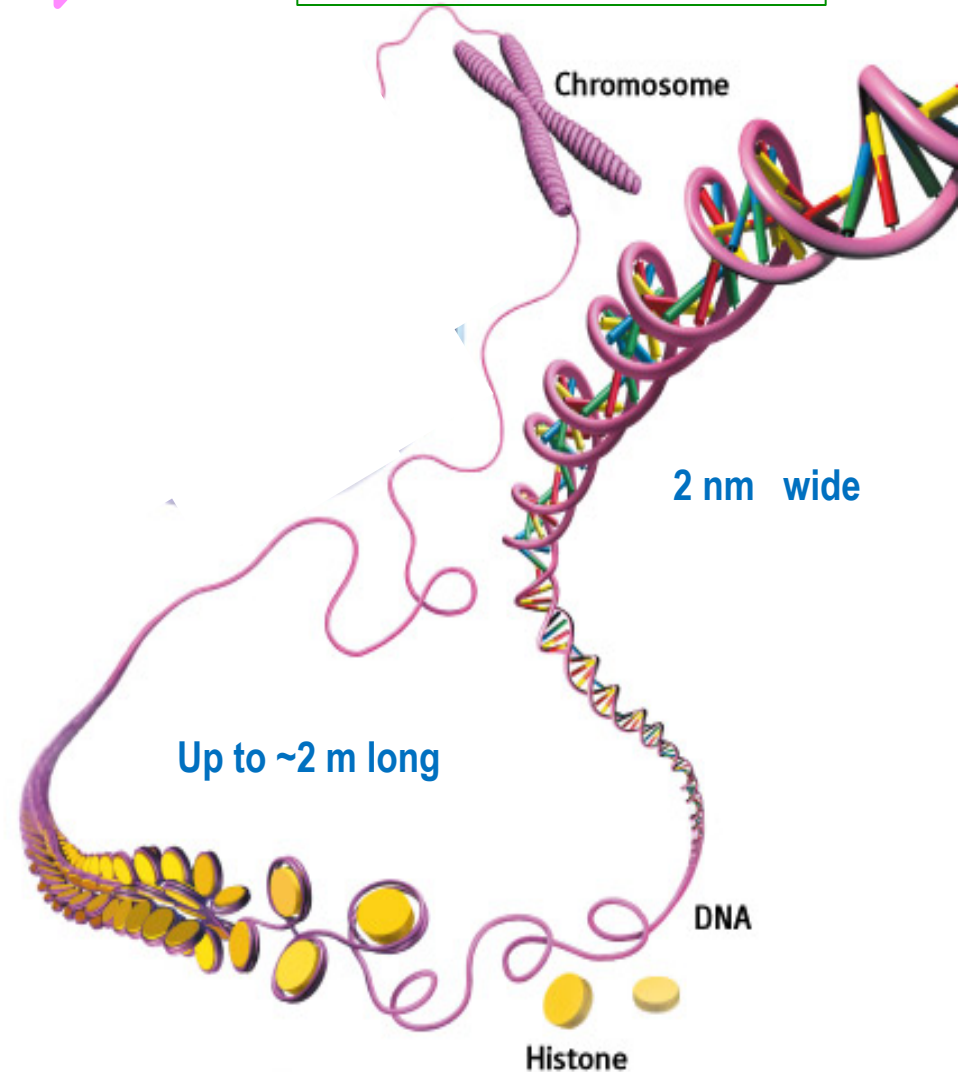

How to observe the “Origin of Life”

- Exactly the same way as we look for the “Origin of Universe”

Telescope ↔ Microscope

- We must look for “Live Life”
- Take advantages of the state of art “Photon Detectors” in particle physics.

Seven steps of cosmic evolution

Spontaneous Symmetry Breaking

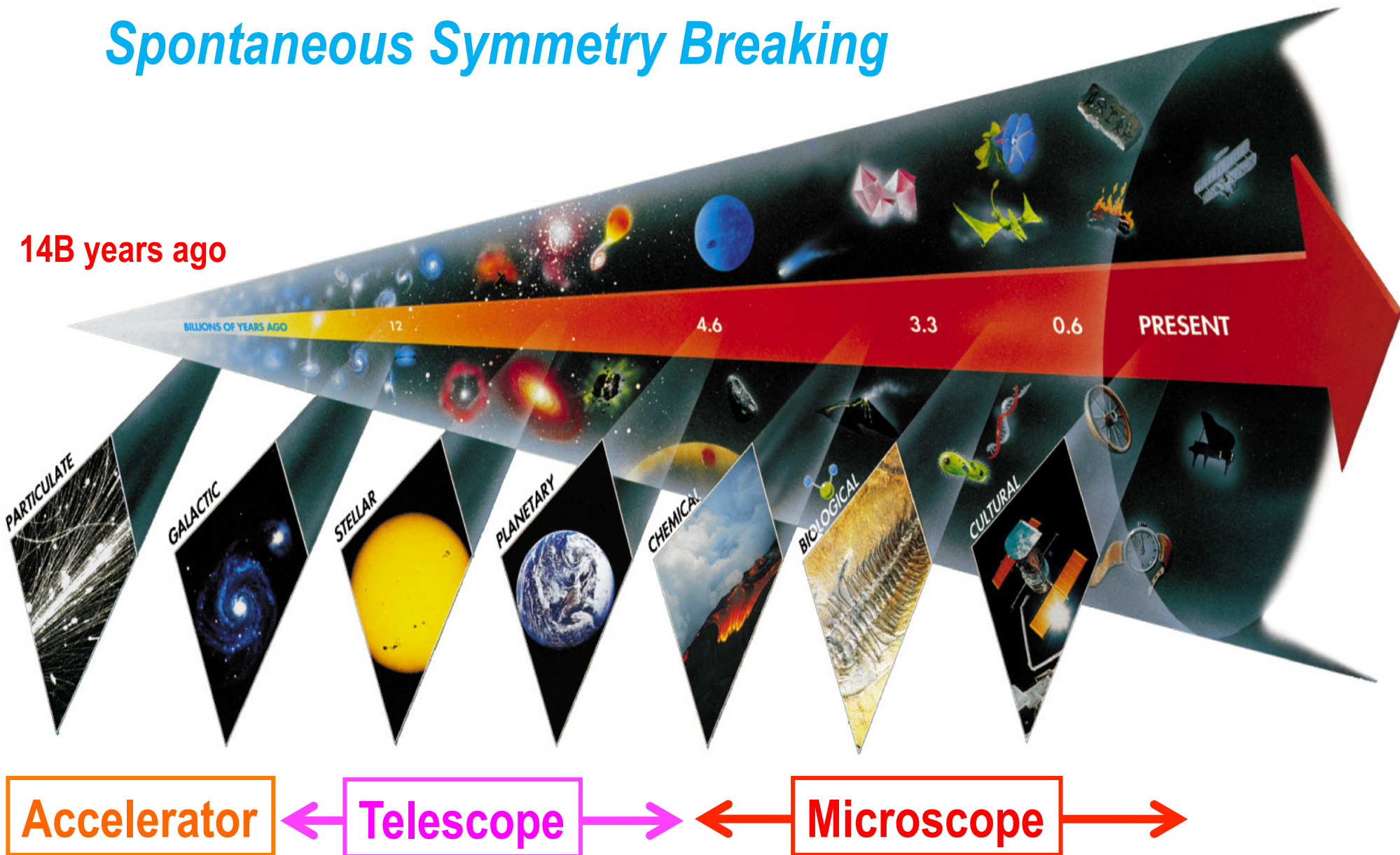

Single Molecule Imaging

Nano Technology

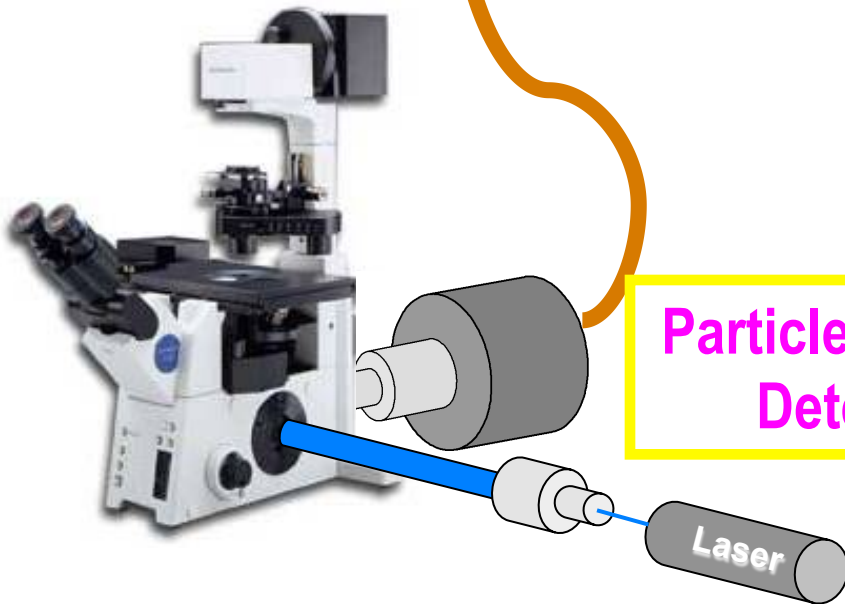
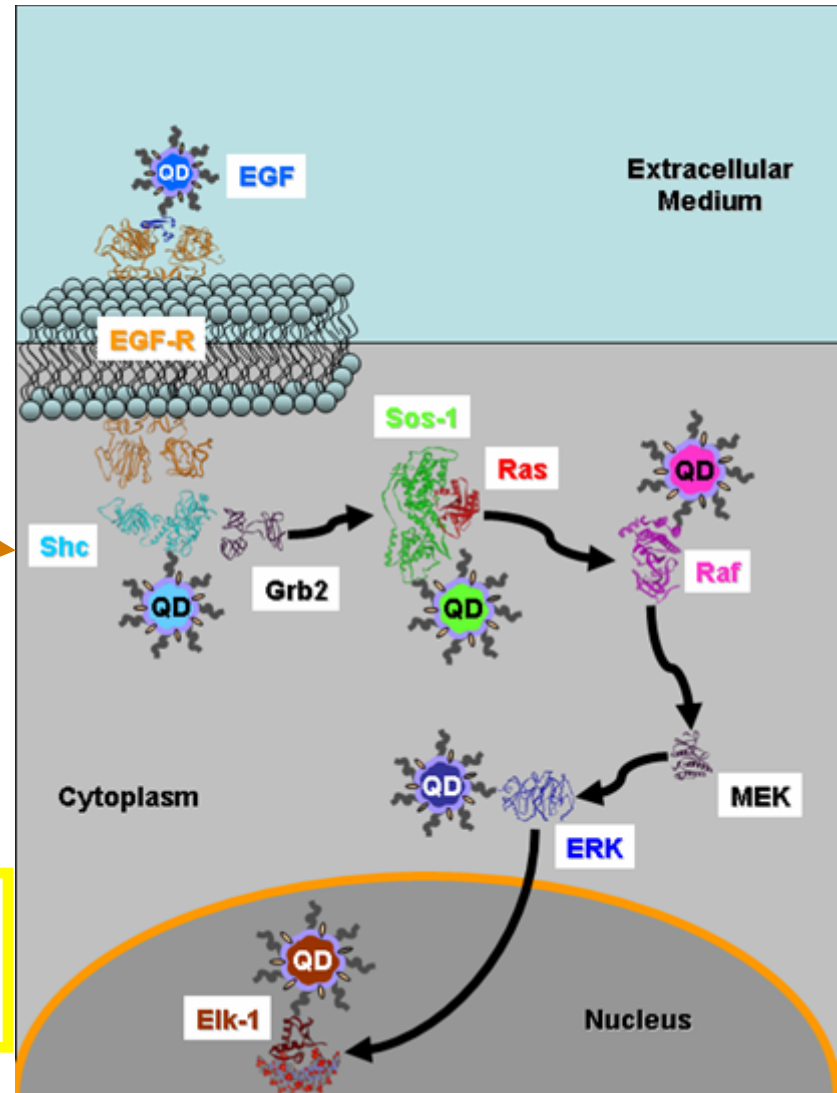

Particle Physics
Detector

Prof. Shimon Weiss

Gold nano particle (40nm) attached to Transferrin Receptor (TfR) on Cancer Cell

Prof. Manuel Penichet (Oncology)

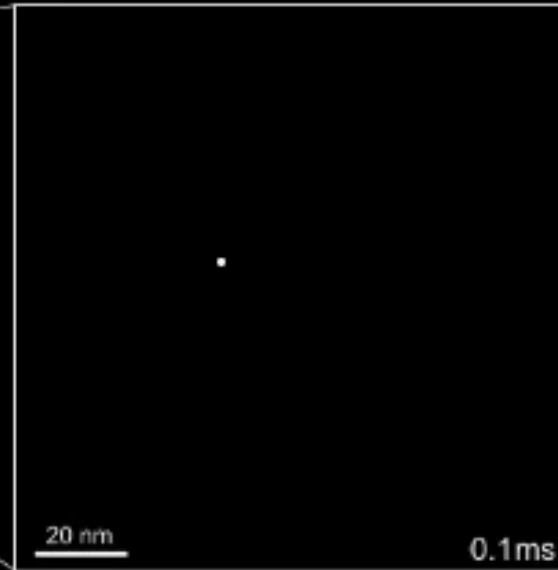
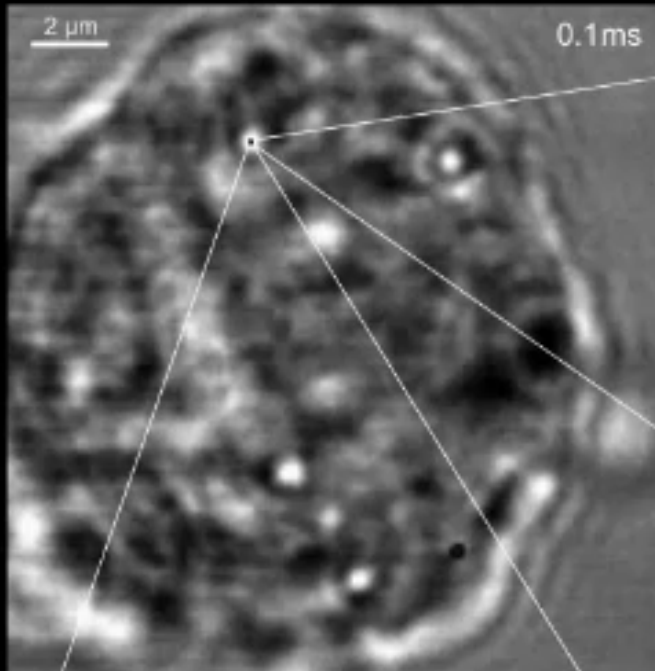

(10,000 frame/sec)

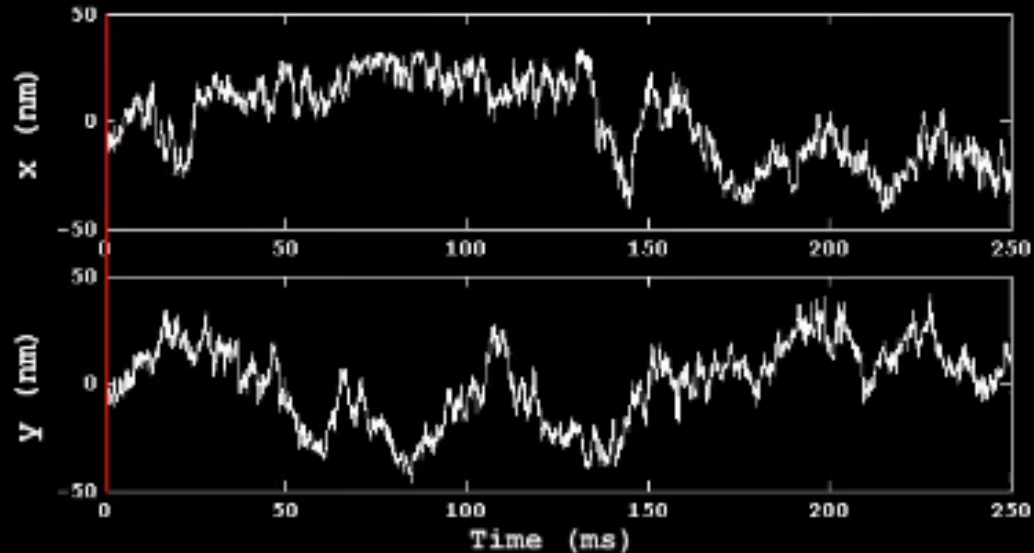
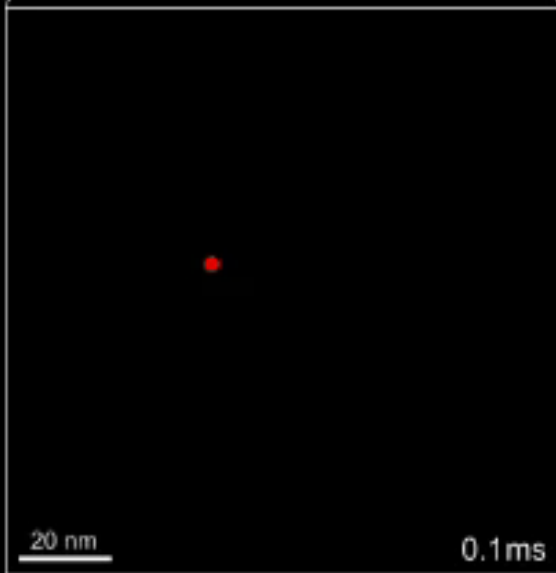

UCLA Fast Bio-Imaging Group

L. Fredrickson, J. Rodriguez, A. Cheng, K. Jewhurst, J. Miao, K. Arisaka

Arisaka's Campus-wide Collaborations on High-Speed Bio-imaging

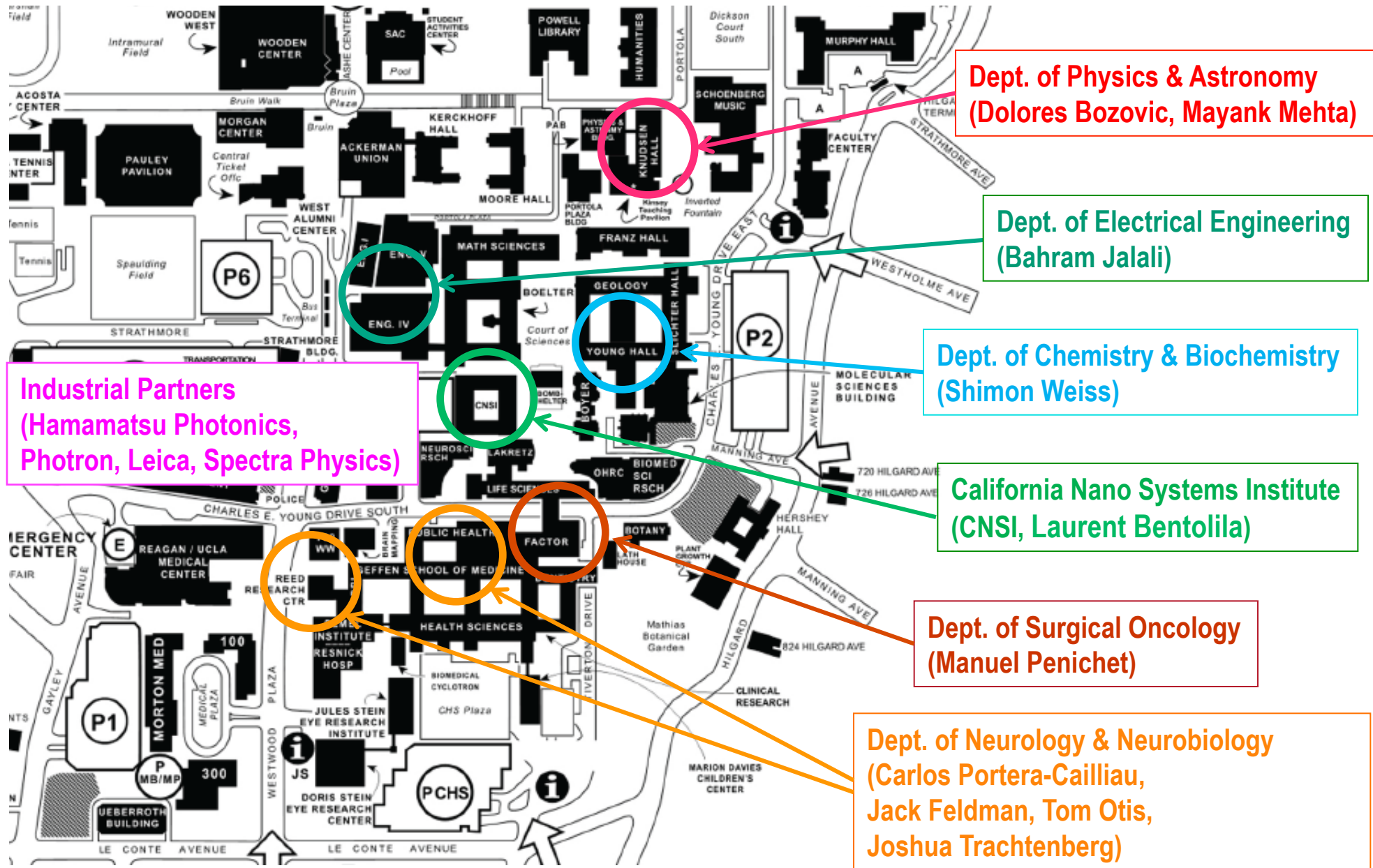

Seven Phases of Cosmic Evolution

Spontaneous Symmetry Breaking

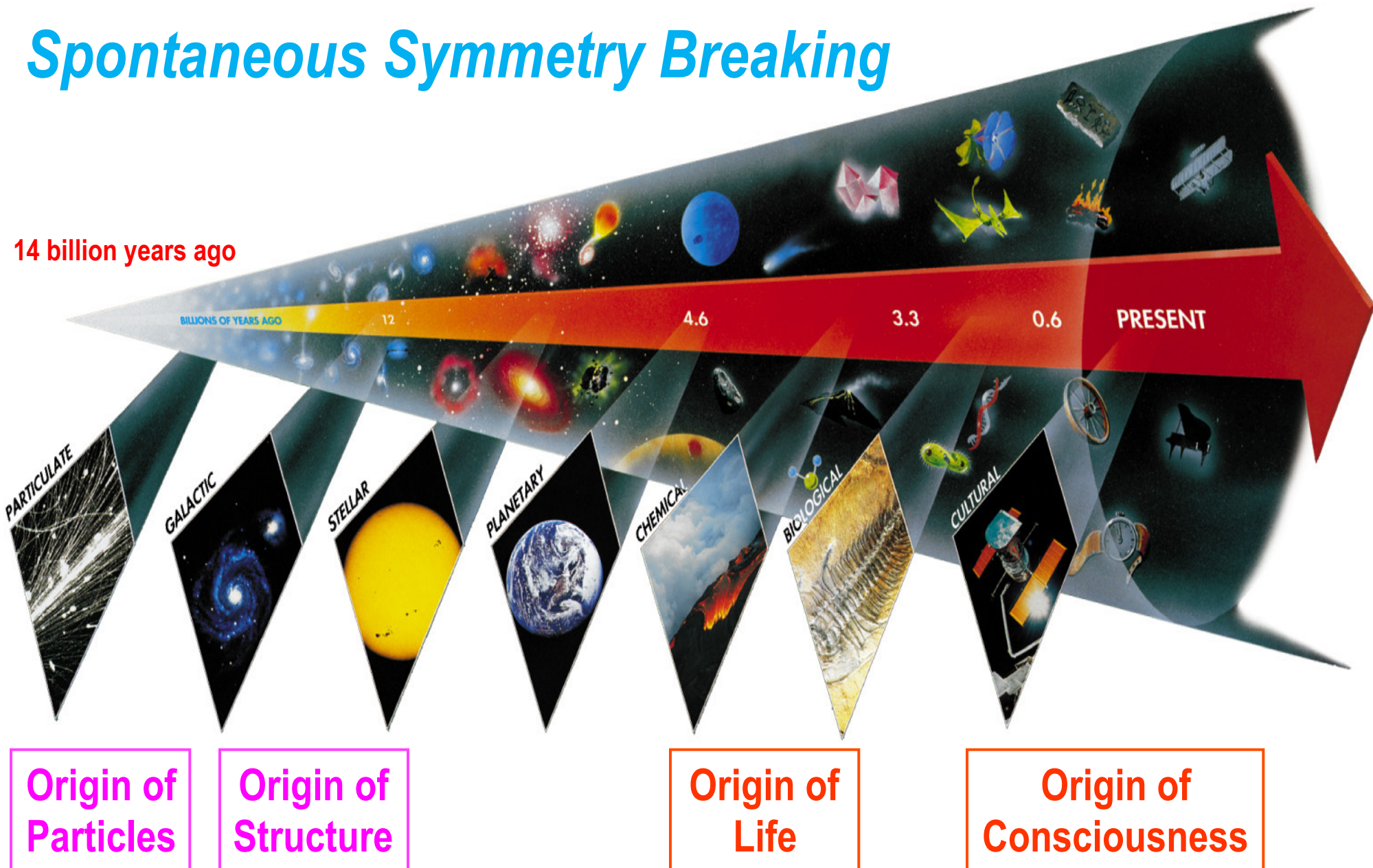

Brain

Universe

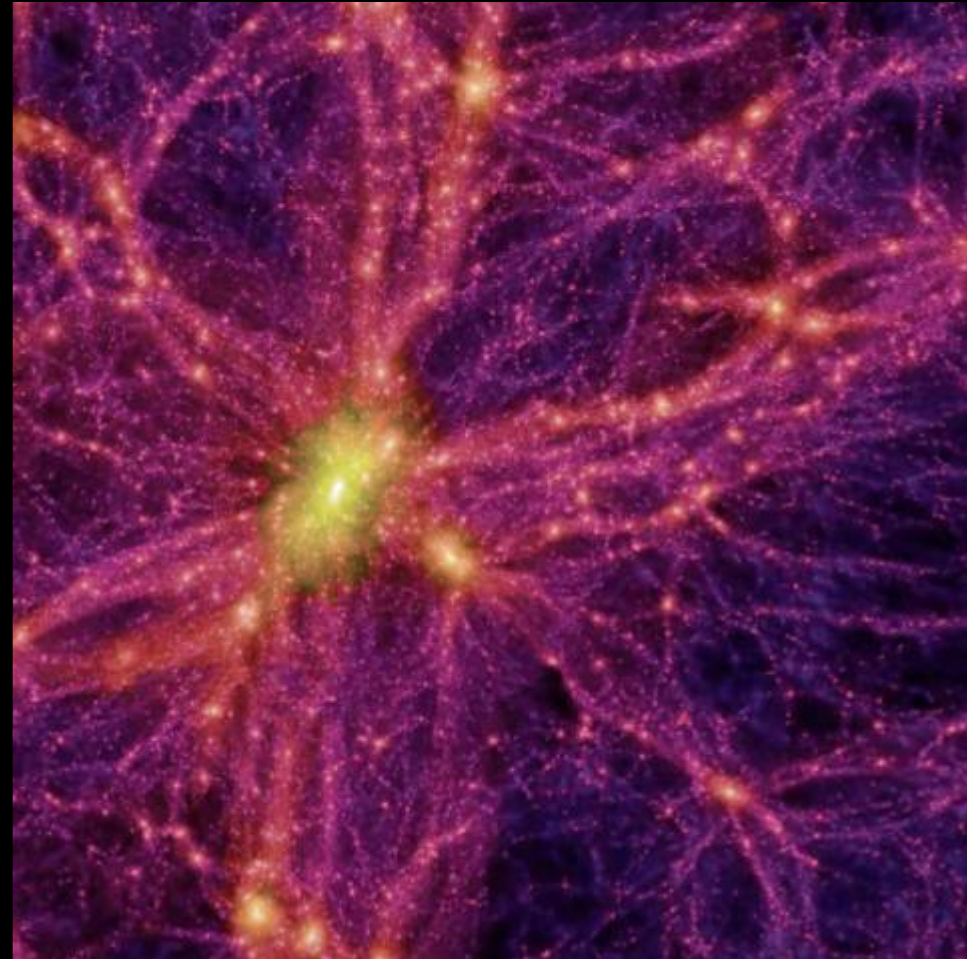
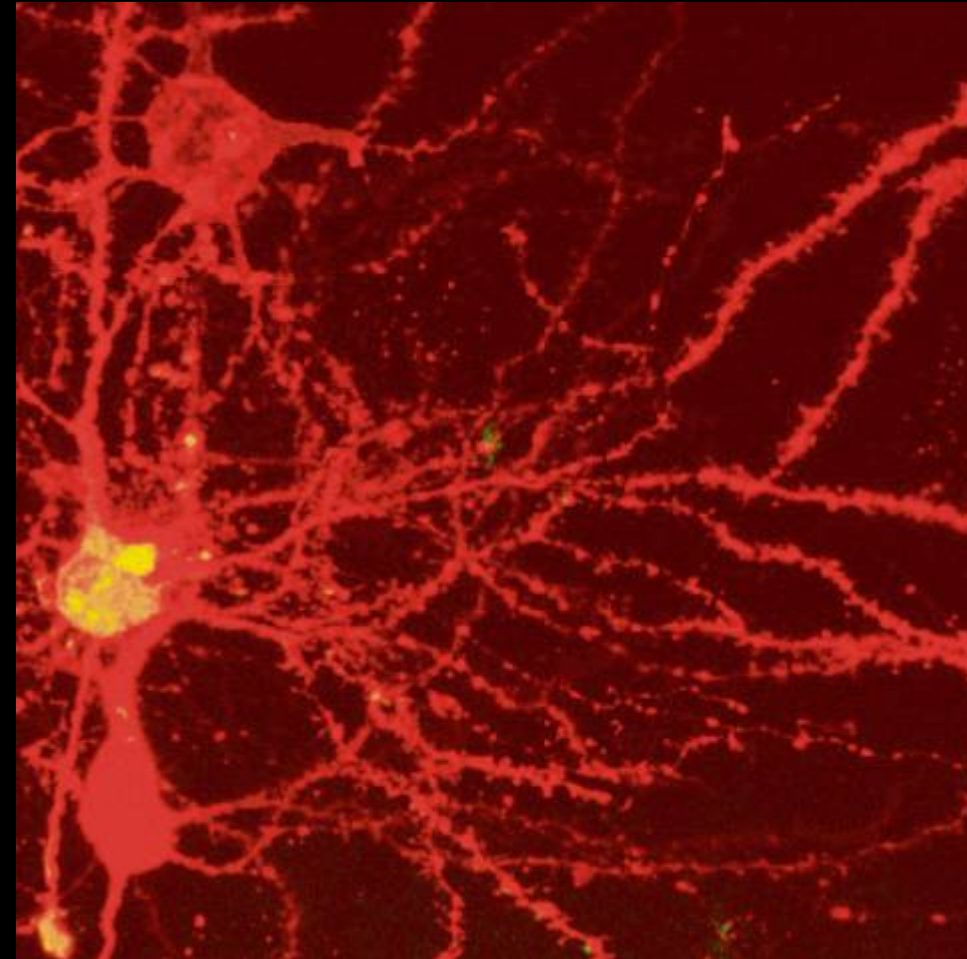

100 Billions Neurons

100 Billions Galaxies

Ca²⁺ Signal in cultivated Rat's Brain

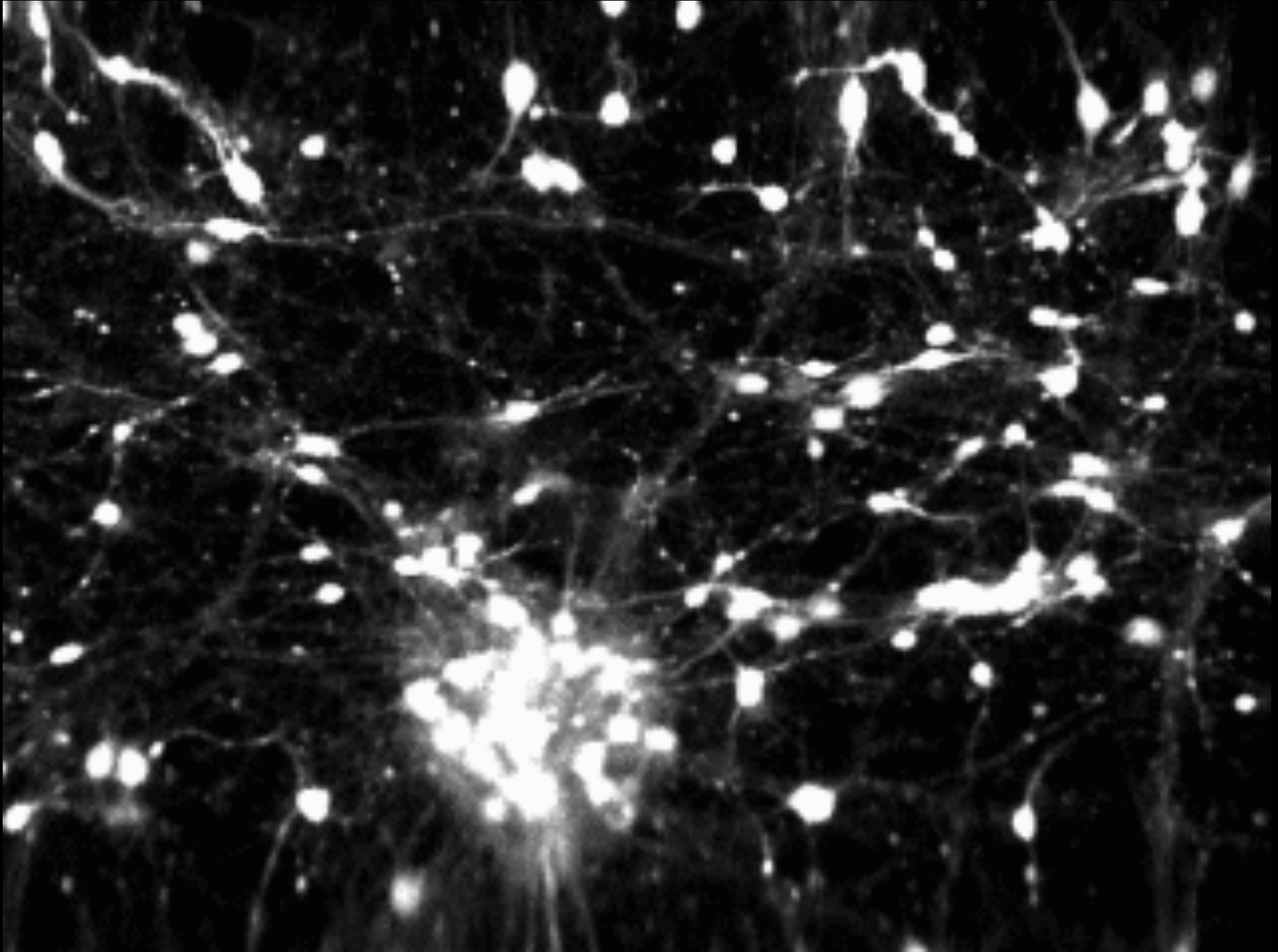

Assembly of cortical circuits during development

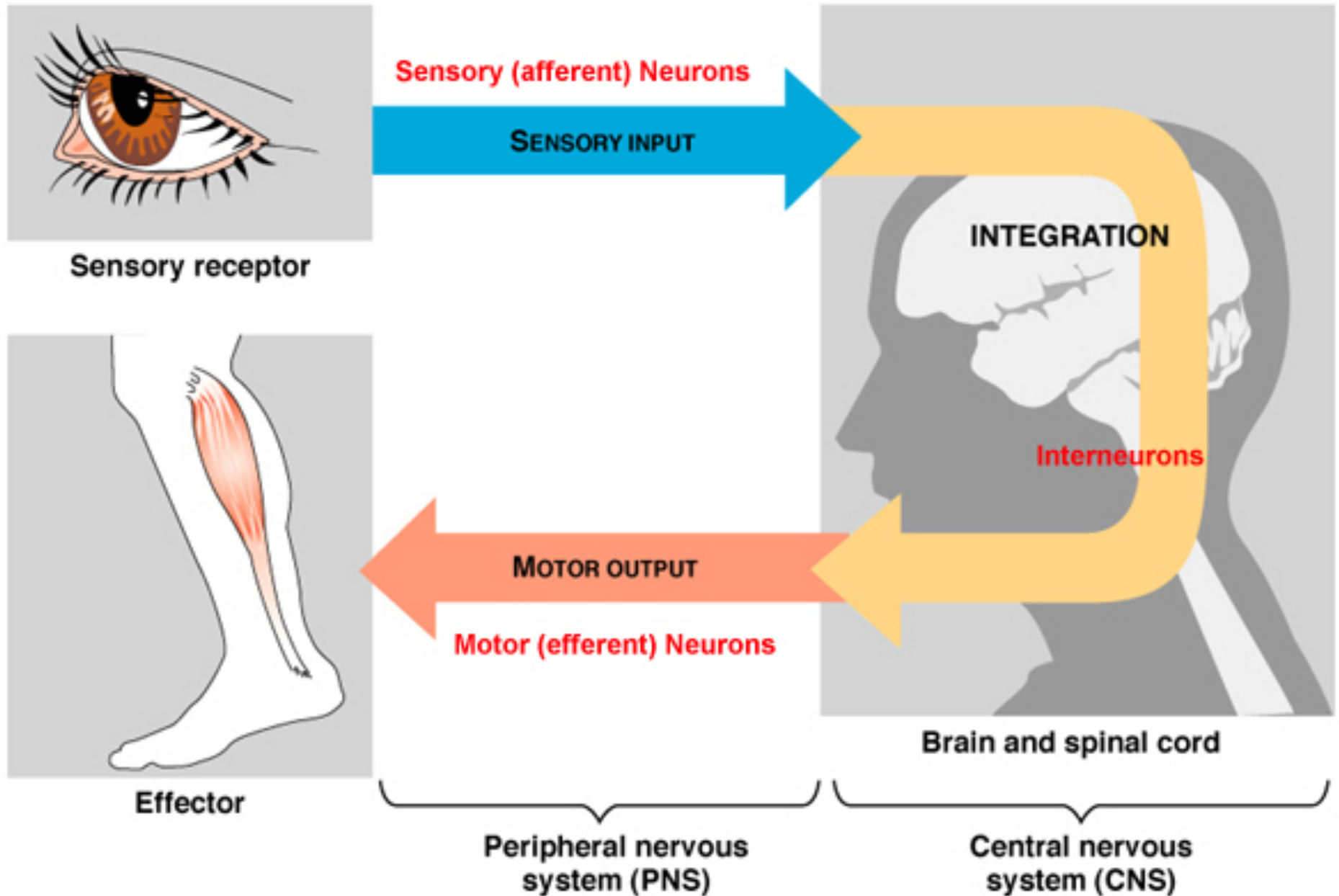

Human Eyes

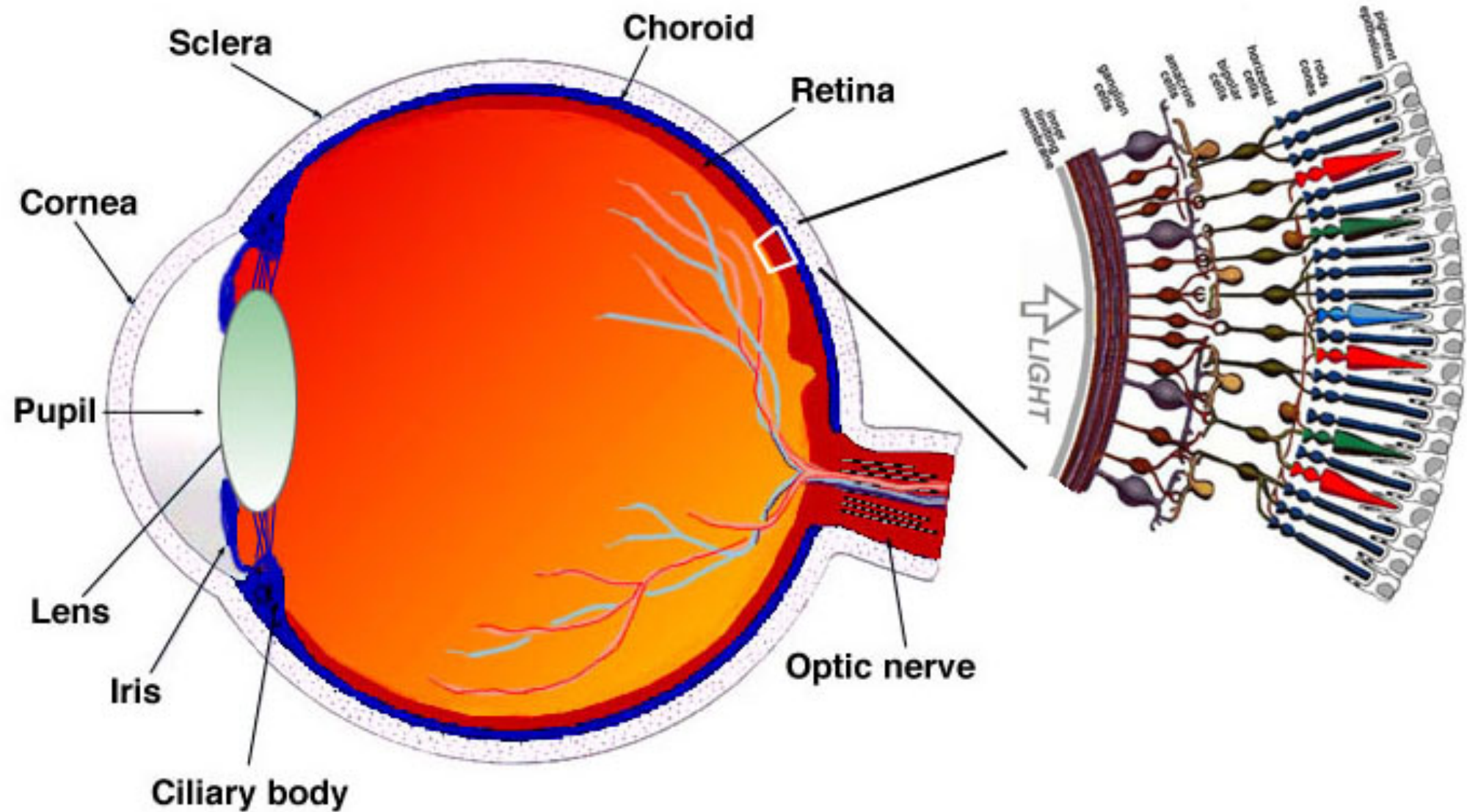

How can I recognize a woman so far away?



- Genetically encoded?
- Learning and memory?

Nature vs. Nurture

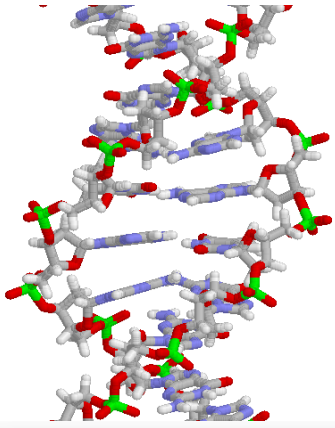

Nature

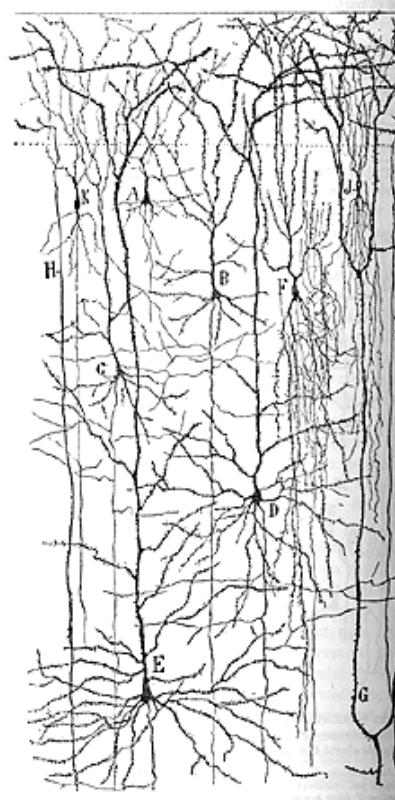

Nurture

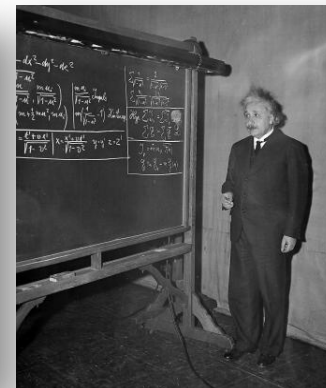
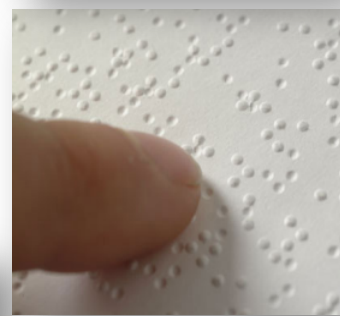
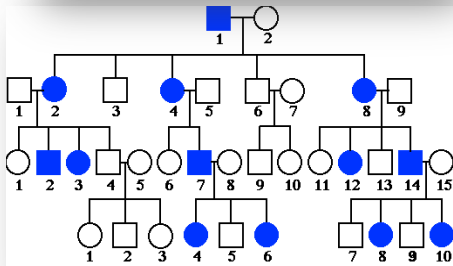

In vivo calcium imaging of neuronal activity

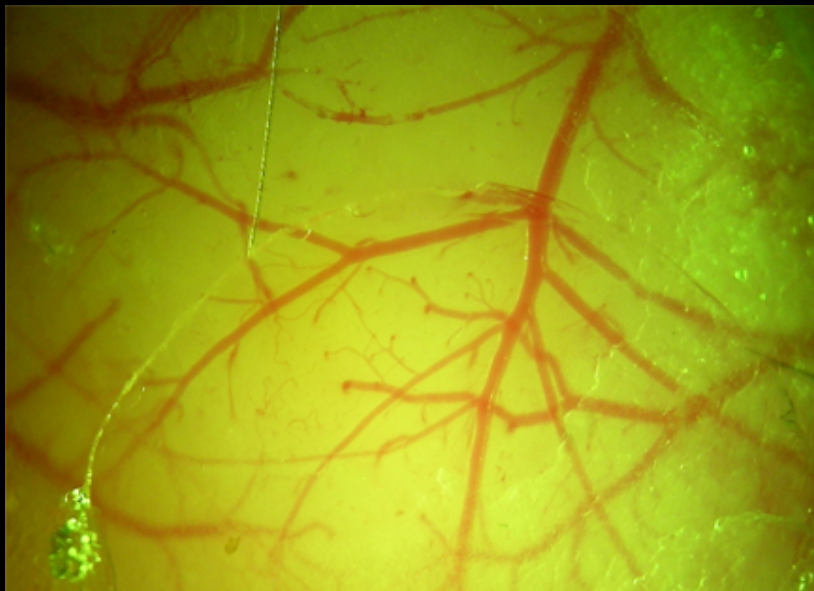
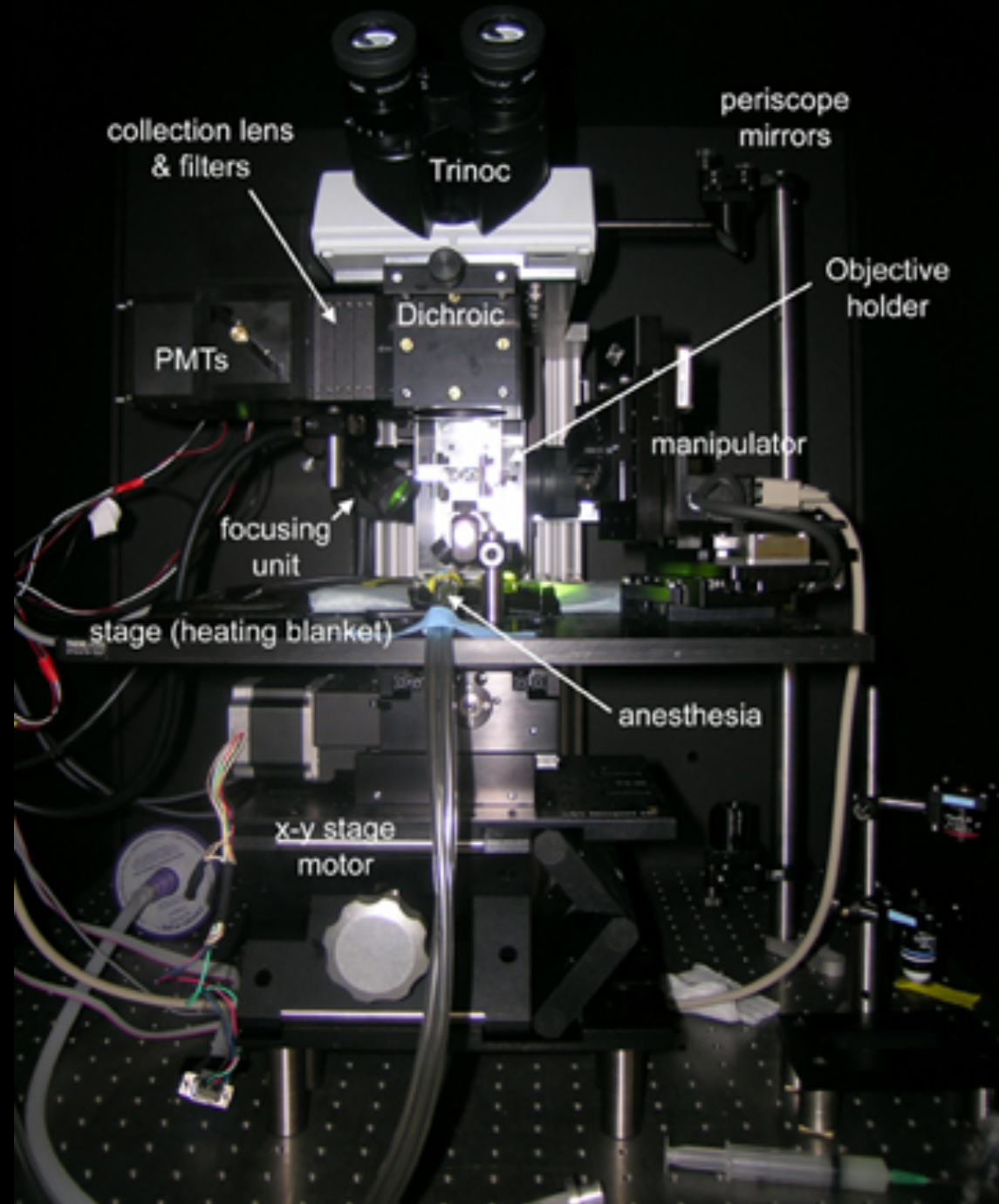
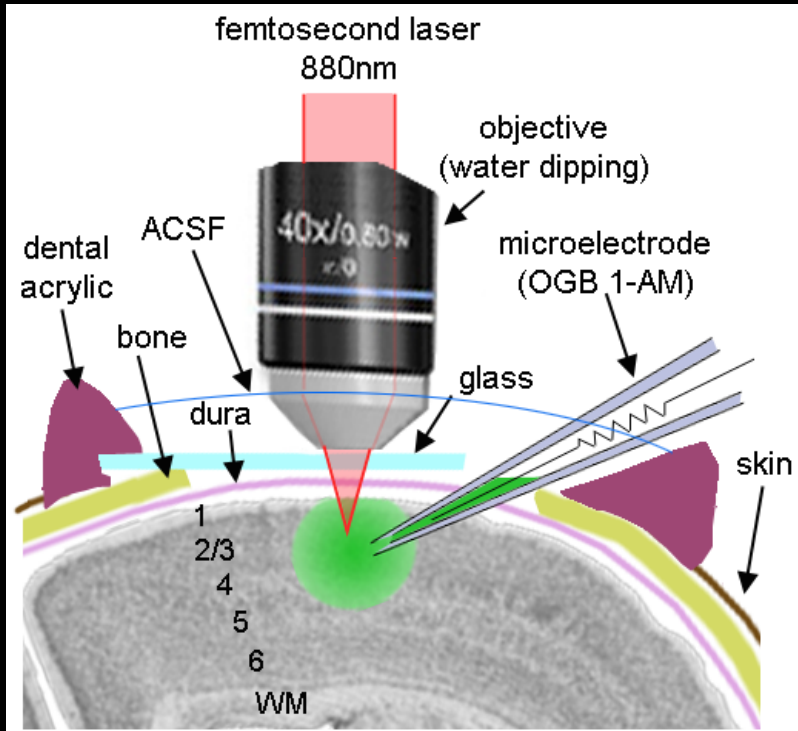

In vivo calcium imaging of Barrel Cortex of Mouse

**Barrel Cortex
Layer 2/3**

150 μm deep

**240 fps
Raw Data**

**(x3 faster
than real)**

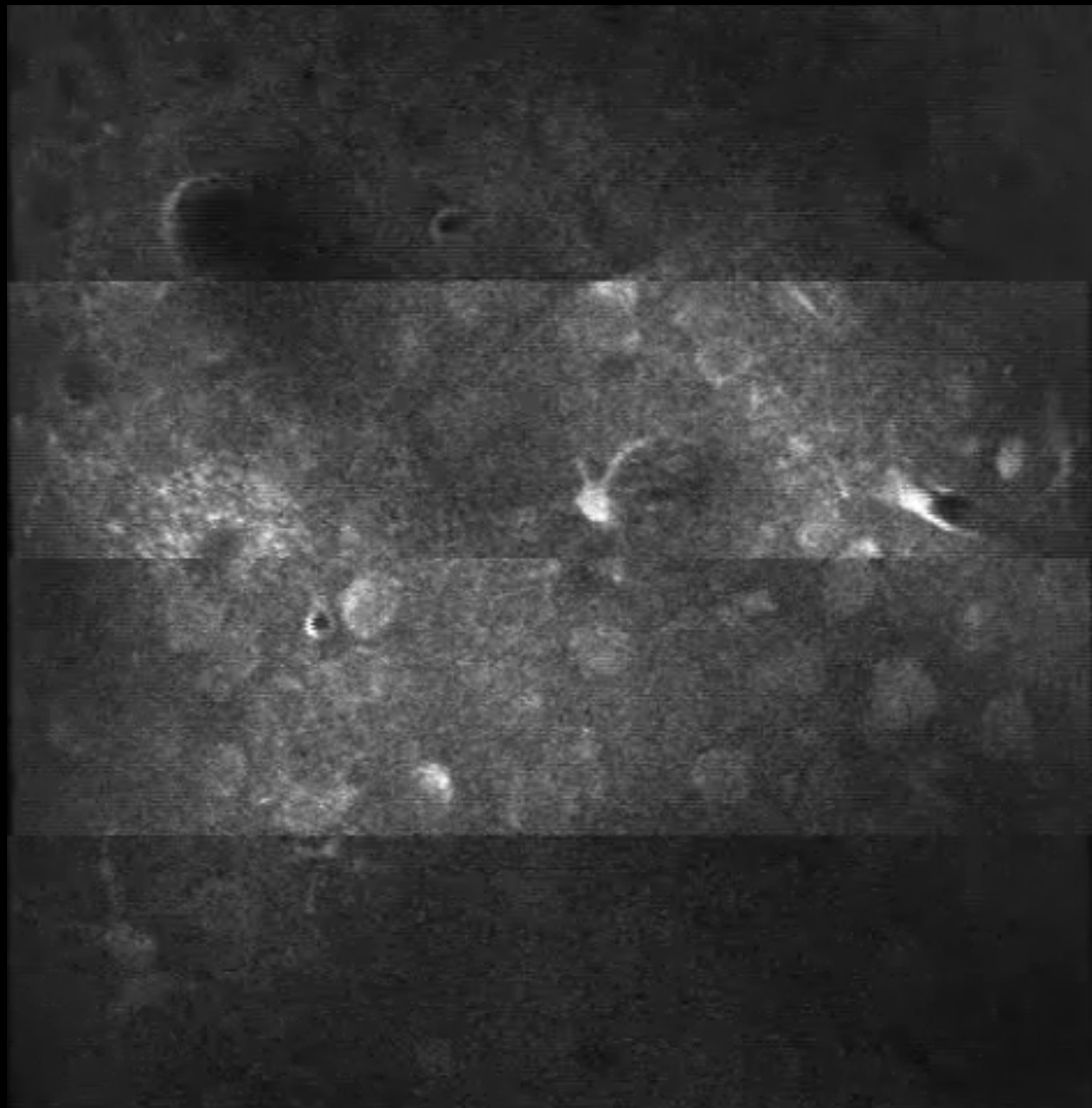

**Beam 1
(0 ns)**

**Beam 2
(+3 ns)**

**Beam 3
(+6 ns)**

**Beam 4
(+9 ns)**

← 300 μm →

In vivo calcium imaging of Barrel Cortex of Mouse

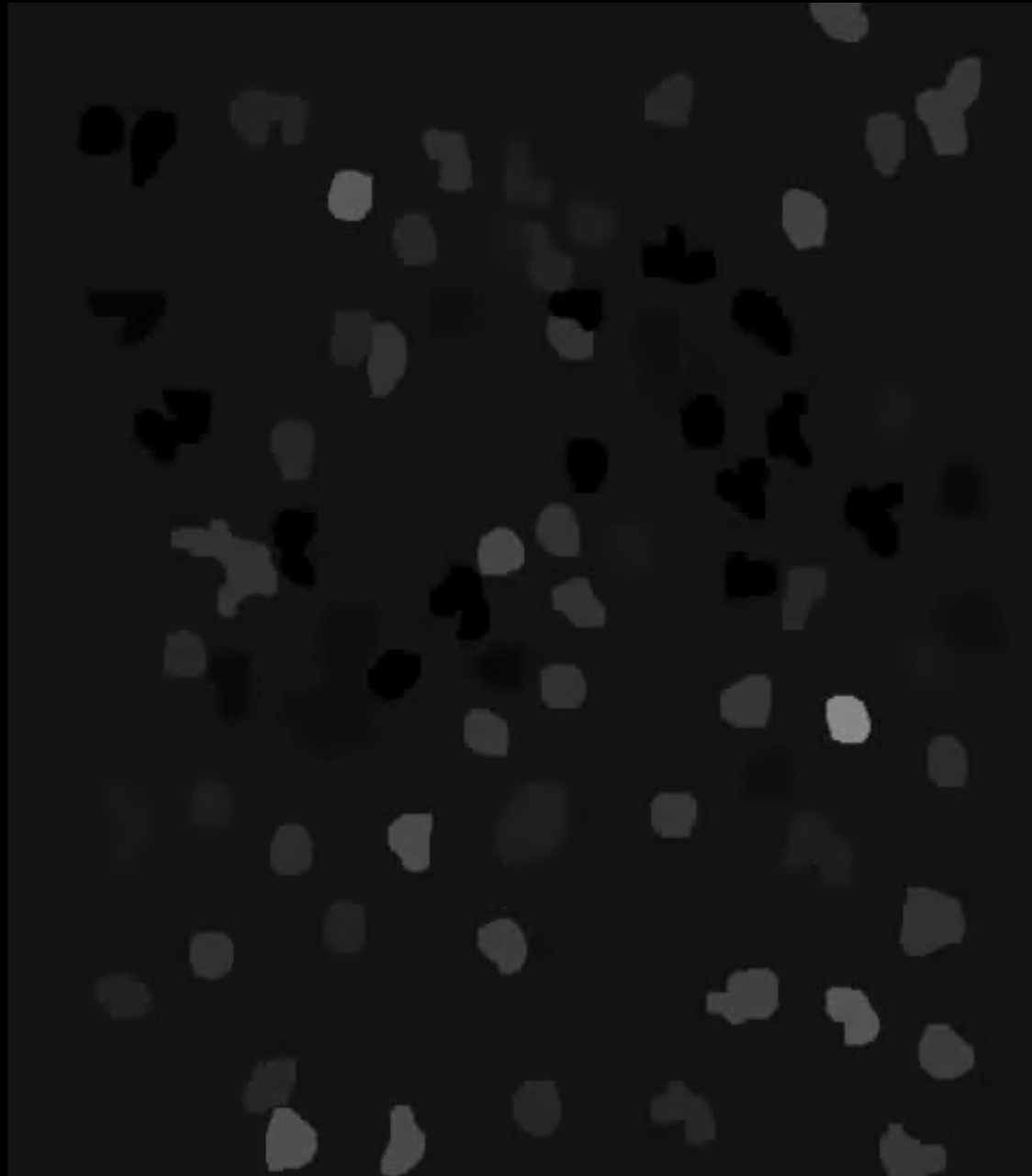

**Barrel
Cortex
Layer 2/3**

**150 μm
deep**

**After
averaging**

**(x3 faster
than real)**

58 neurons

*(~100 billions
neurons
in our brain)*

← 300 μm →

Origin of the Brain

- **Brains were evolved for animals to predict necessary motions for survival.**
 - **Find preys**
 - **Escape away from predators**
 - **Find mates for sex**
- **A brain “consciously” makes the best decision at a given time.**
- **Complex activities of brains are the results of evolution of life.**

Activity of (excitatory) pyramidal neurons in CA depends on rat's position: place cells

Mayank Mehta (Physics, Neurology)

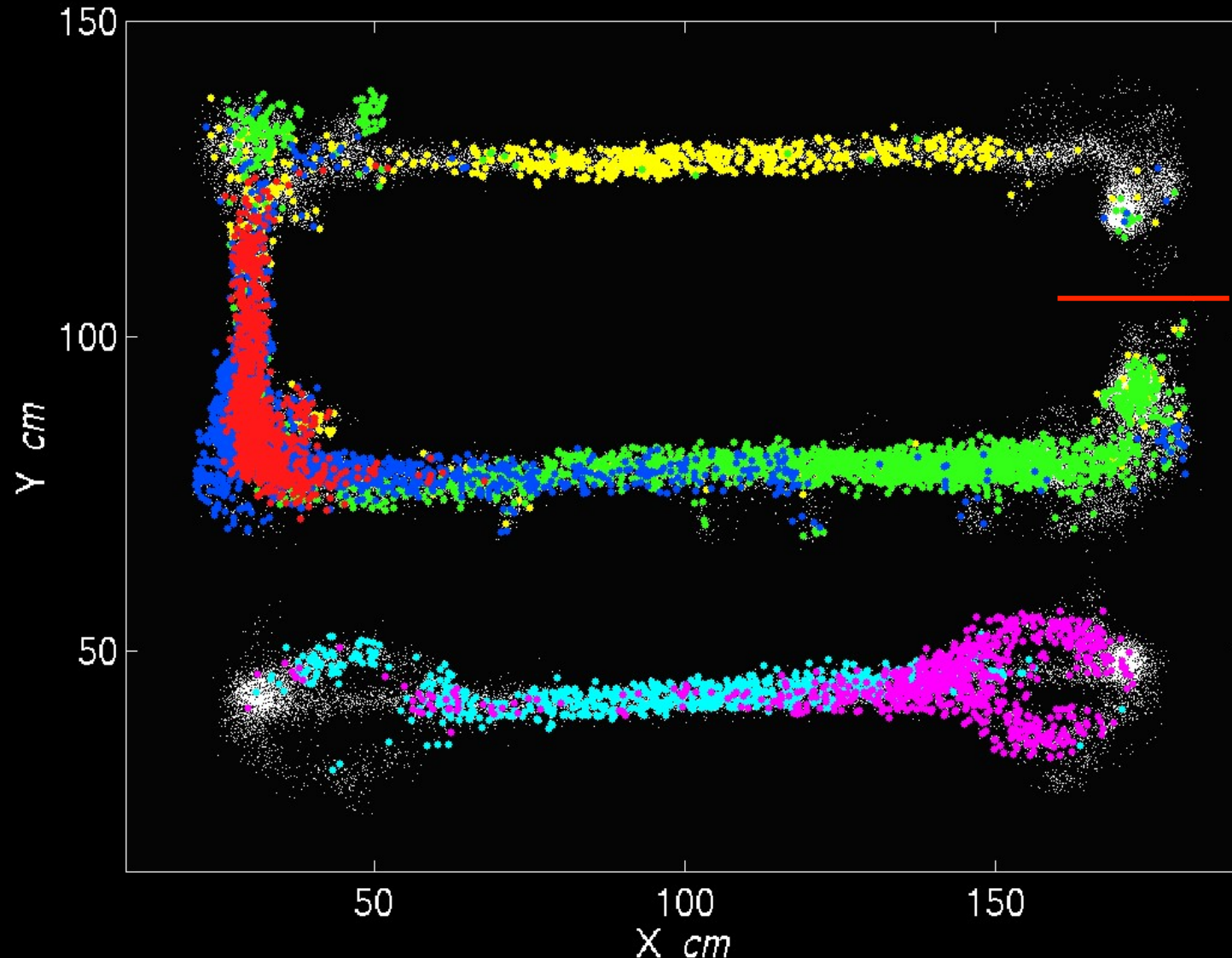

Hippocampus has a cognitive map of space

Learning and Memory by Hippocampus

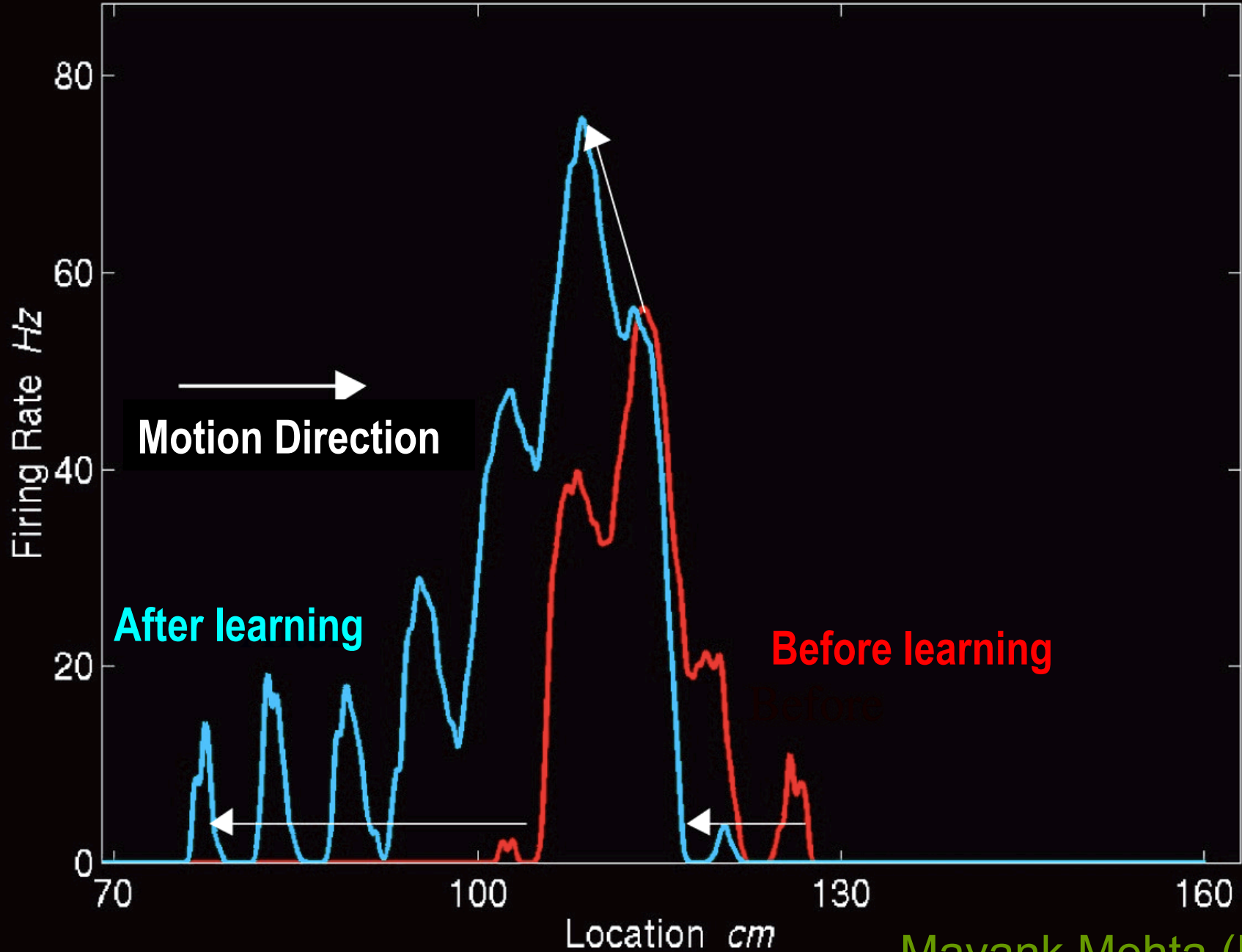

Virtual Reality Experiment on Awake Rats

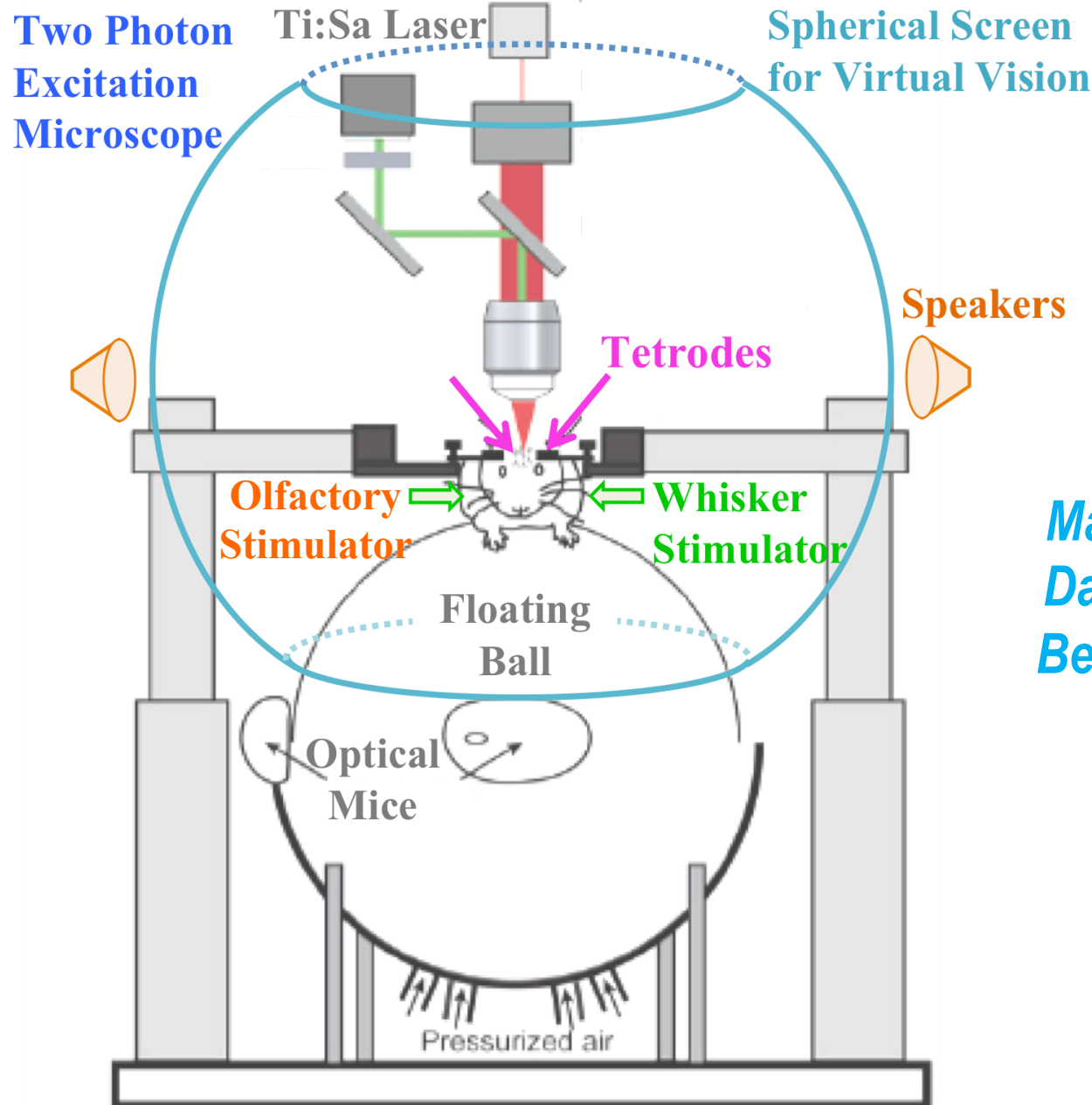

*Mayank Mehta
Daniel Aharoni
Bernard Willers*

Seven Phases of Cosmic Evolution

Spontaneous Symmetry Breaking

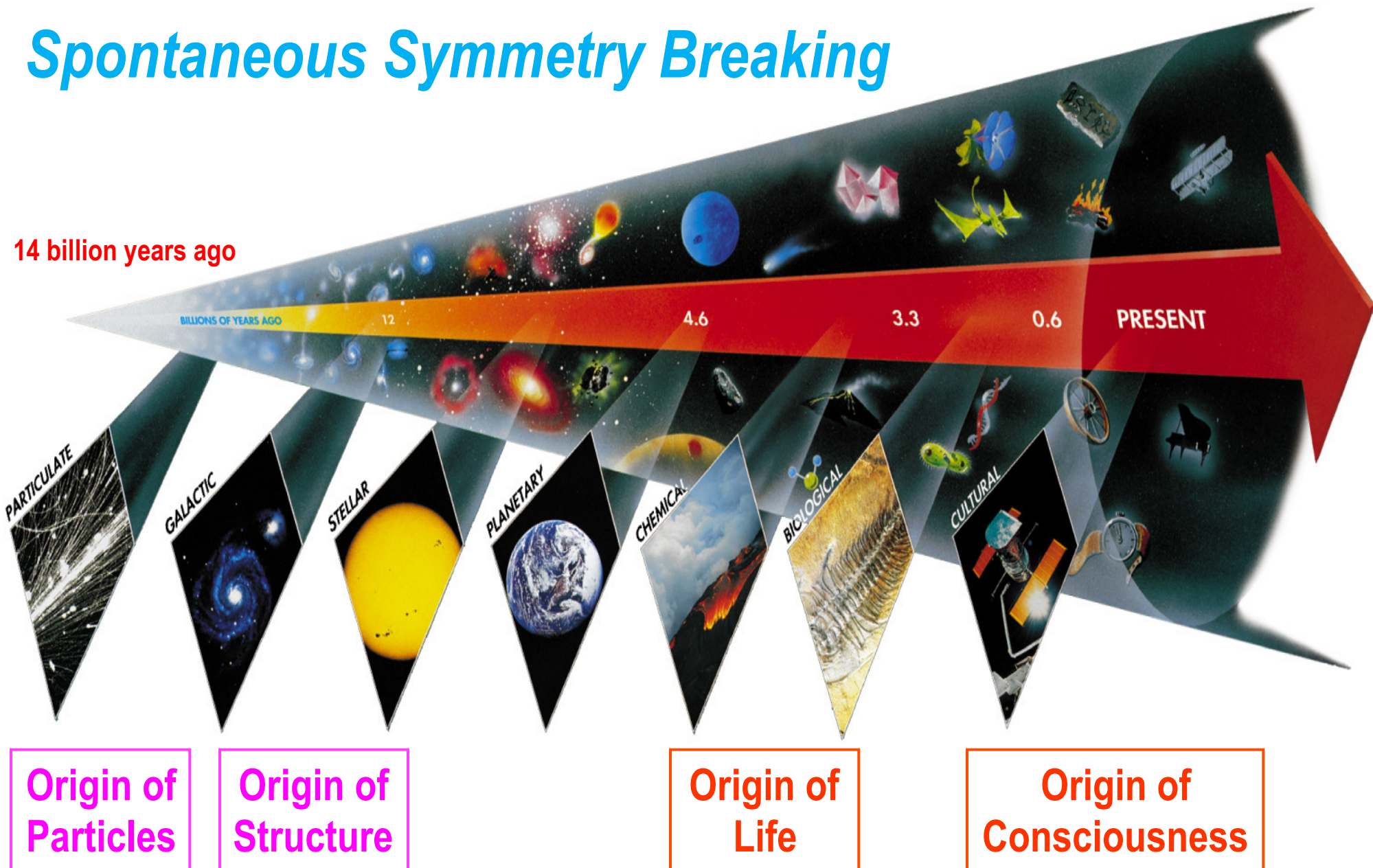



Why are we here?

Cyclic Model

M theory

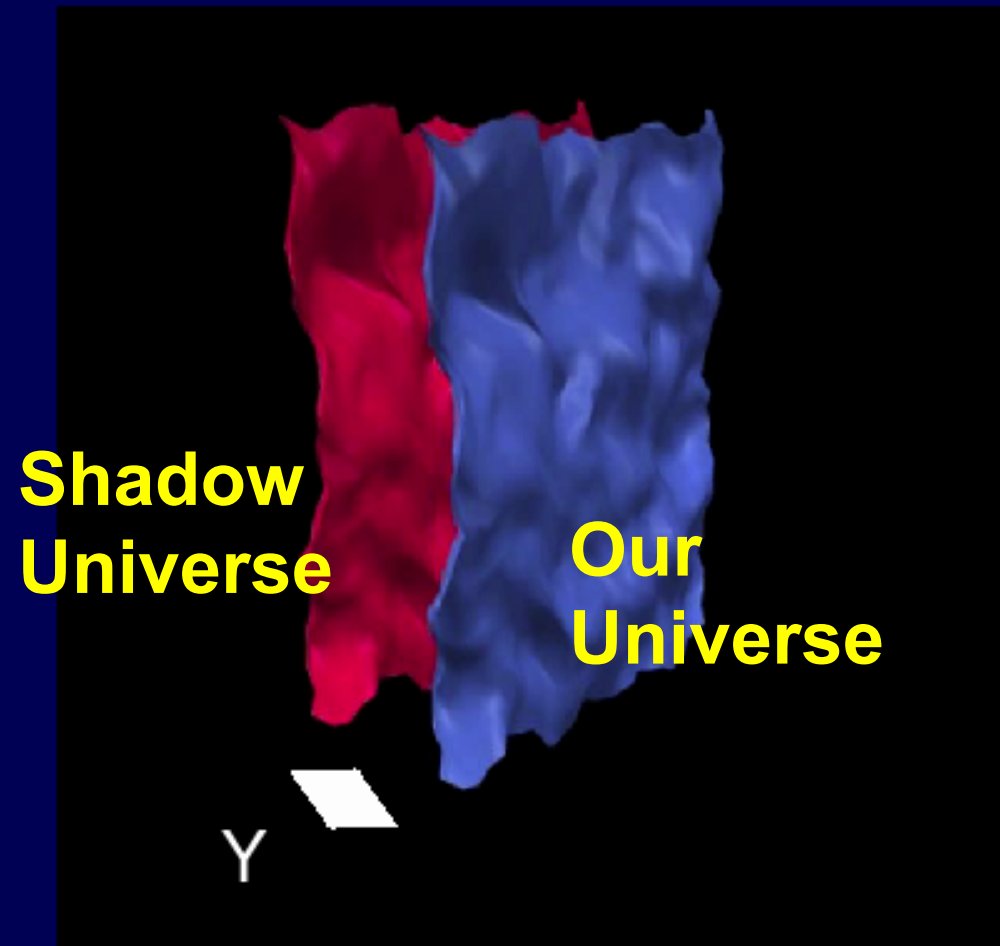
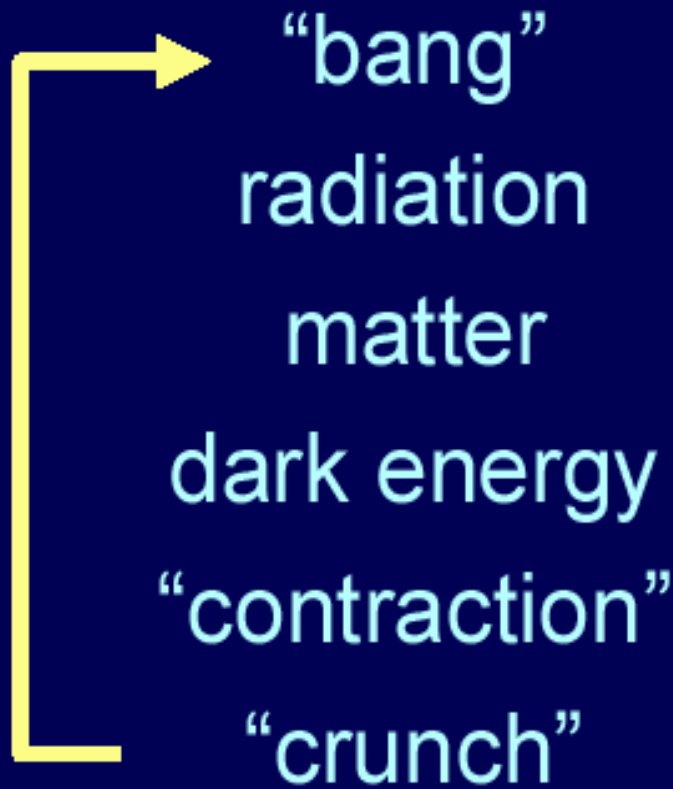

**Are there more than
one Universe?**

Linde's Multiverse by Chaotic Inflation

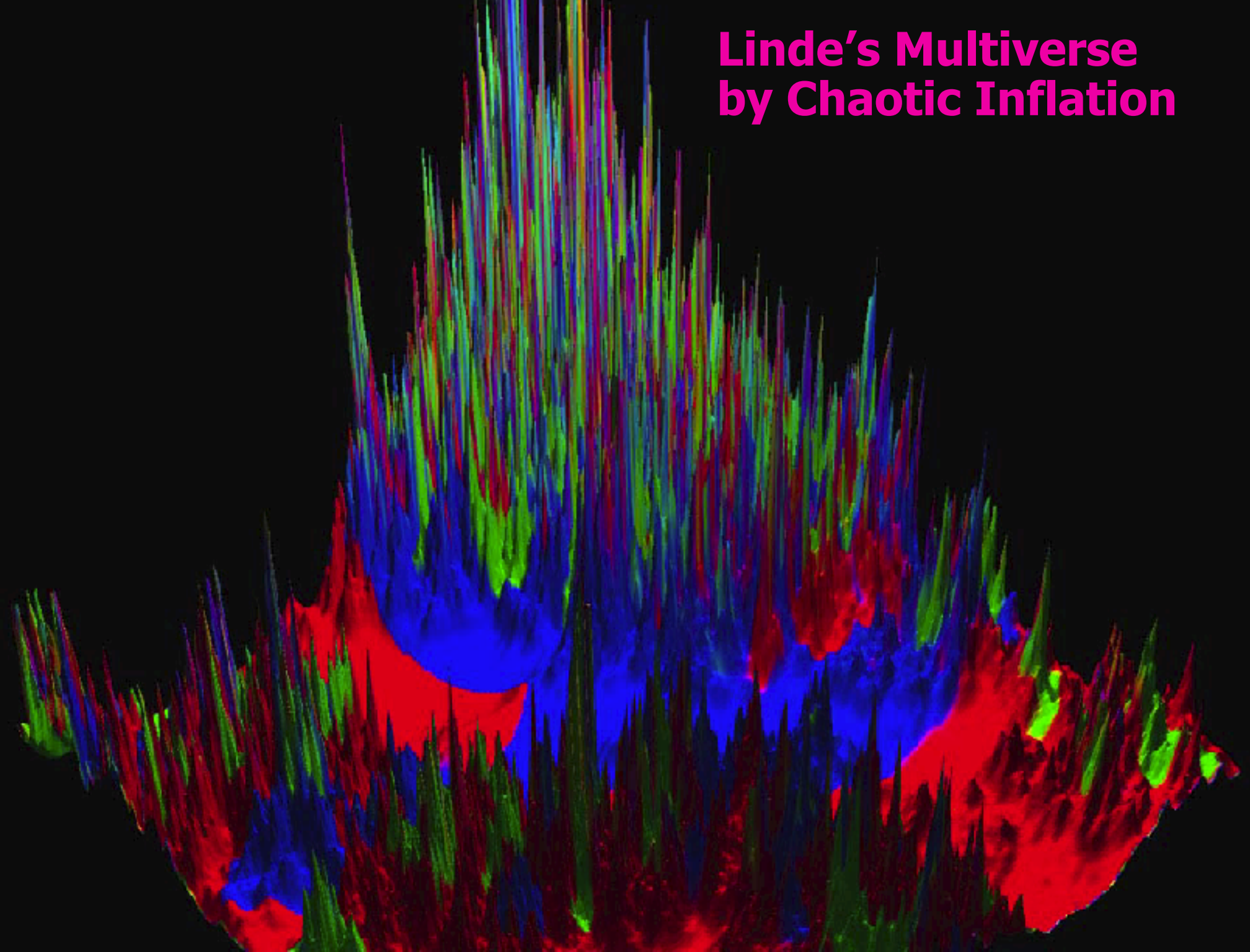



There may be ~100 Billion Universes.

Summary

- **Why are we here?**
 - Endless symmetry breaking → Cosmic evolution
 - Extreme fine tuning required.
- **We are so fortunate to be here today.**
 - Shadow universe?
 - Multiverse?
- **This talk is available at my home page**
 - <http://home.physics.ucla.edu/~arisaka/home/>
 - Under “Presentations”