

Search for Dark Matter: Science Cases and Challenges

Katsushi Arisaka

*University of California, Los Angeles
Department of Physics and Astronomy*

arisaka@physics.ucla.edu

What is Dark Matter?

- They created and shaped the large scale structure of the Universe.
 - Without dark matter, we were not here today.
- We do not sense them since interactions are so weak.
 - There are $\sim 10^7$ in this room.
 - $\sim 10^{12}$ will pass you during this talk.

Talk Outline

➤ Evidences of Dark Mater

- Astronomy
- Cosmology

➤ Dark Matter Candidates

- Particle Physics

➤ Detection Methods

- Production by LHC
- Indirect Observation
- **Direct Detection – New Results from XENON100**

➤ Future Prospects

Andromeda Galaxy

known since 1932 (Jan Oort)

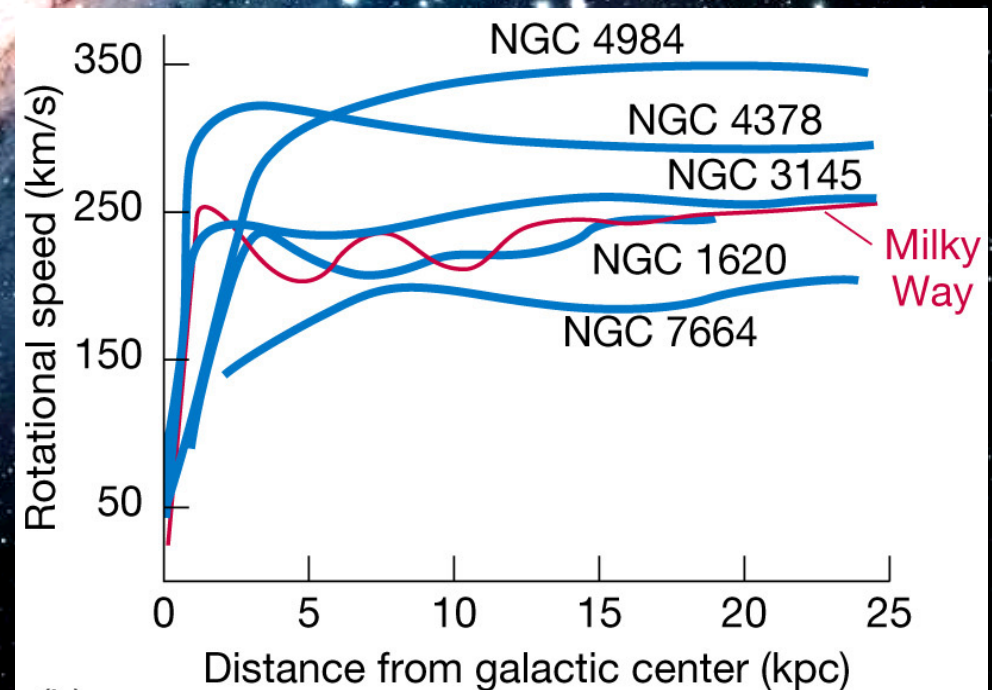

Bullet Cluster

known since 1933 (Fritz Zwicky)

X-ray
(Baryonic)

Weak Lensing
(Total Mass)

1.5'

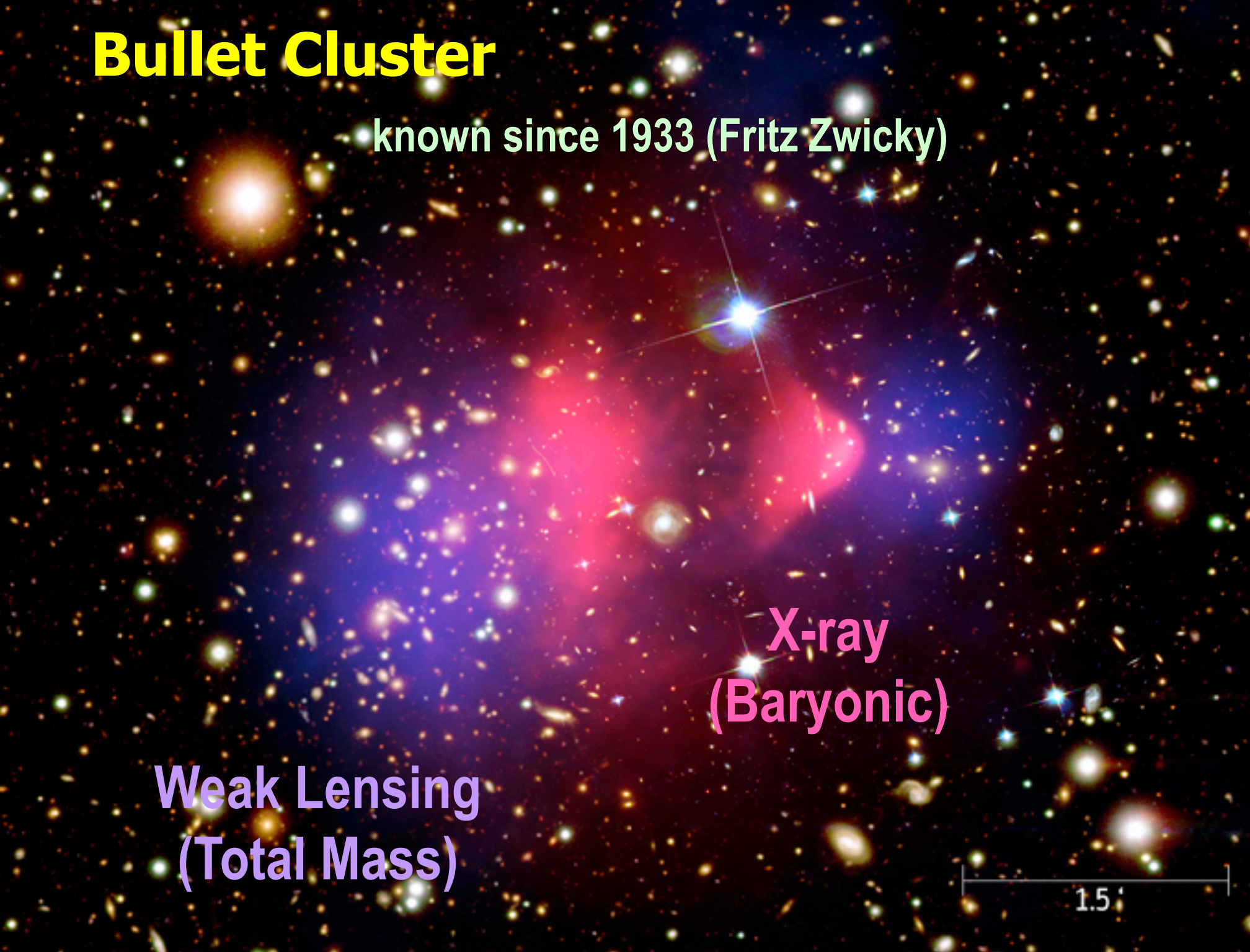

Formation of Structure in the Universe

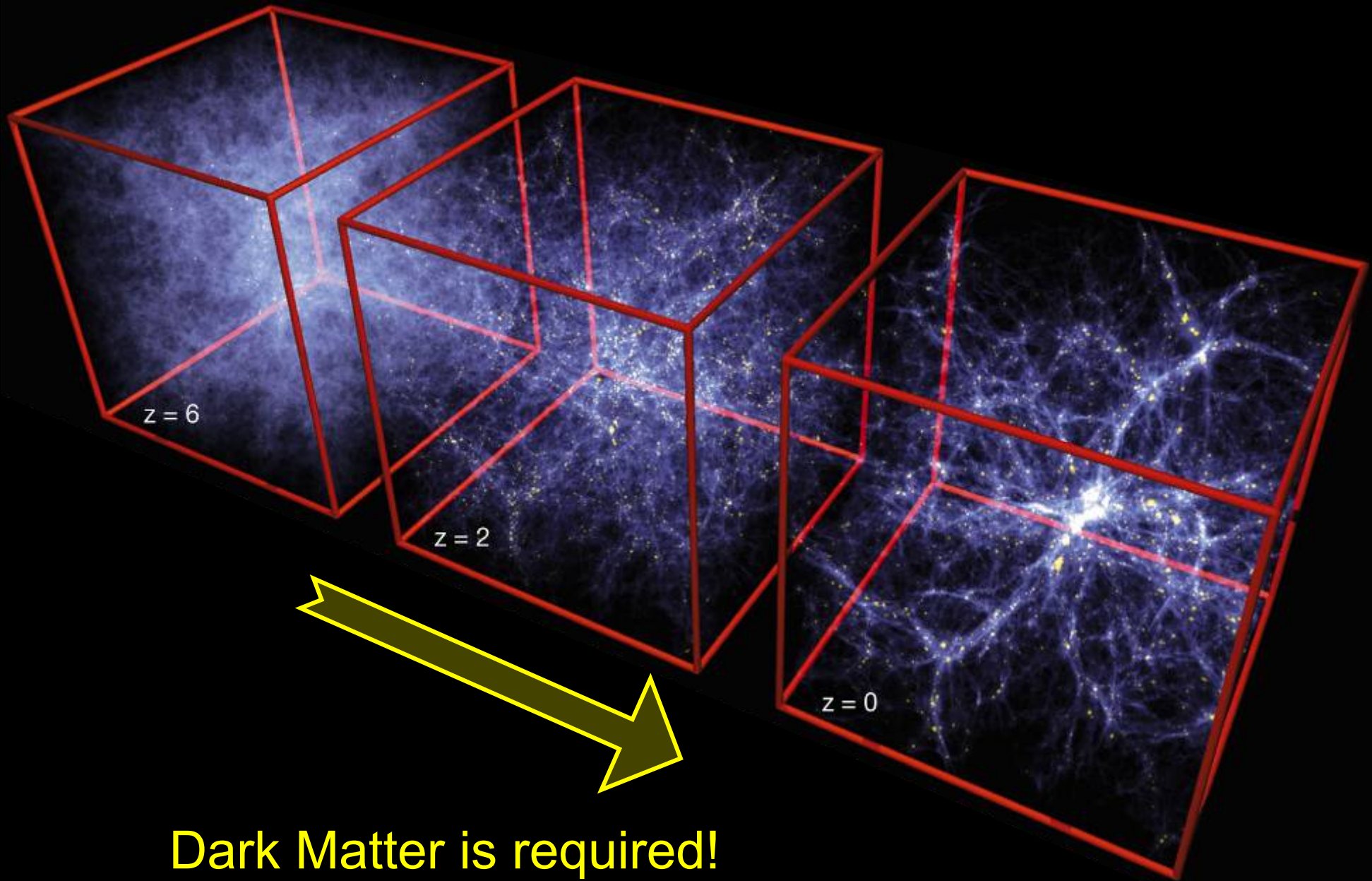

Dark Matter is required!

Density of Our Universe

➤ $\Omega_{\text{Total}} = \Omega_{\Lambda} + \Omega_{\text{Matter}} = 1.0$

➤ Universe is Flat.
⇒ Inflation

➤ 73% is Dark Energy.
⇒ Accelerating

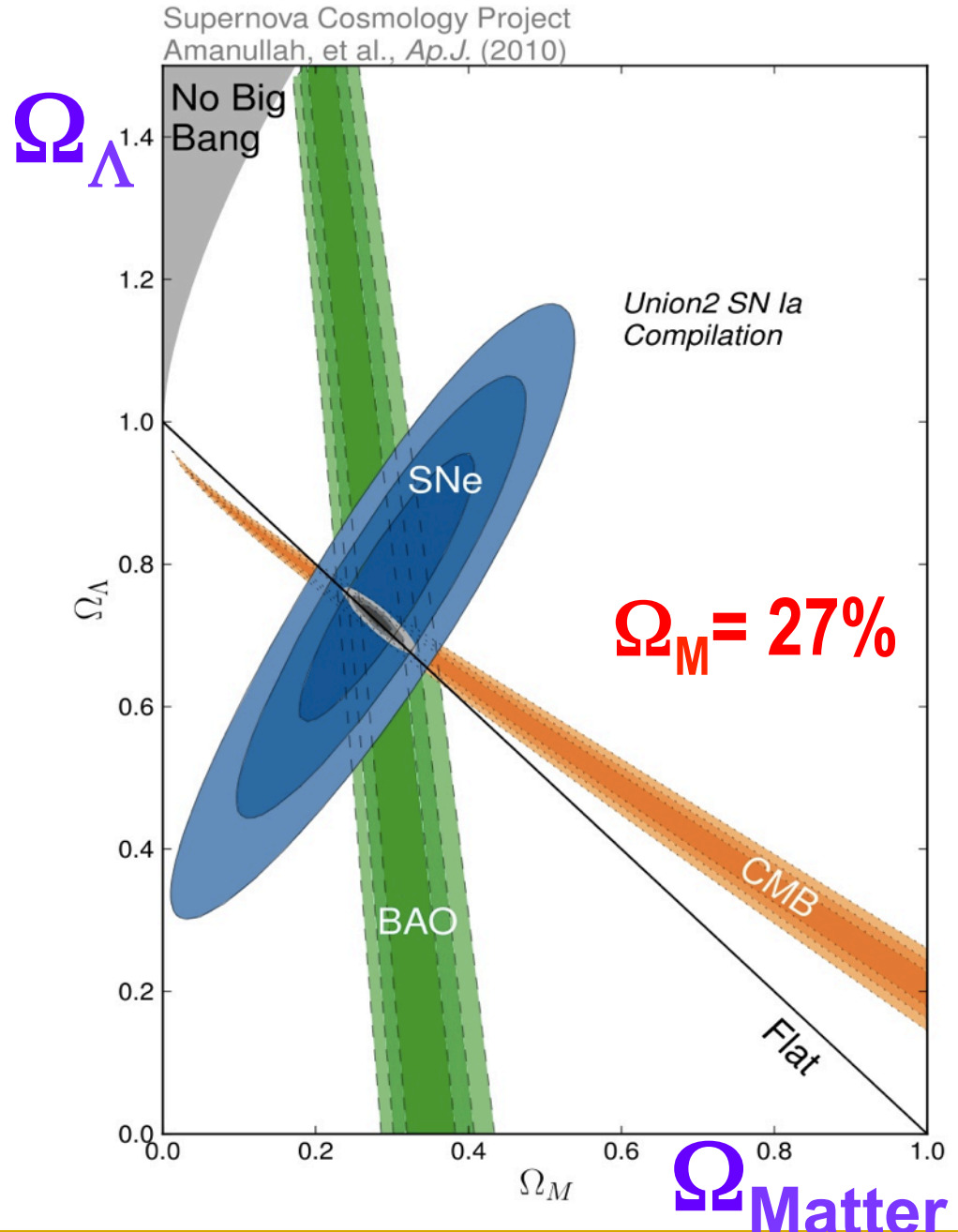

Abundance vs. Density

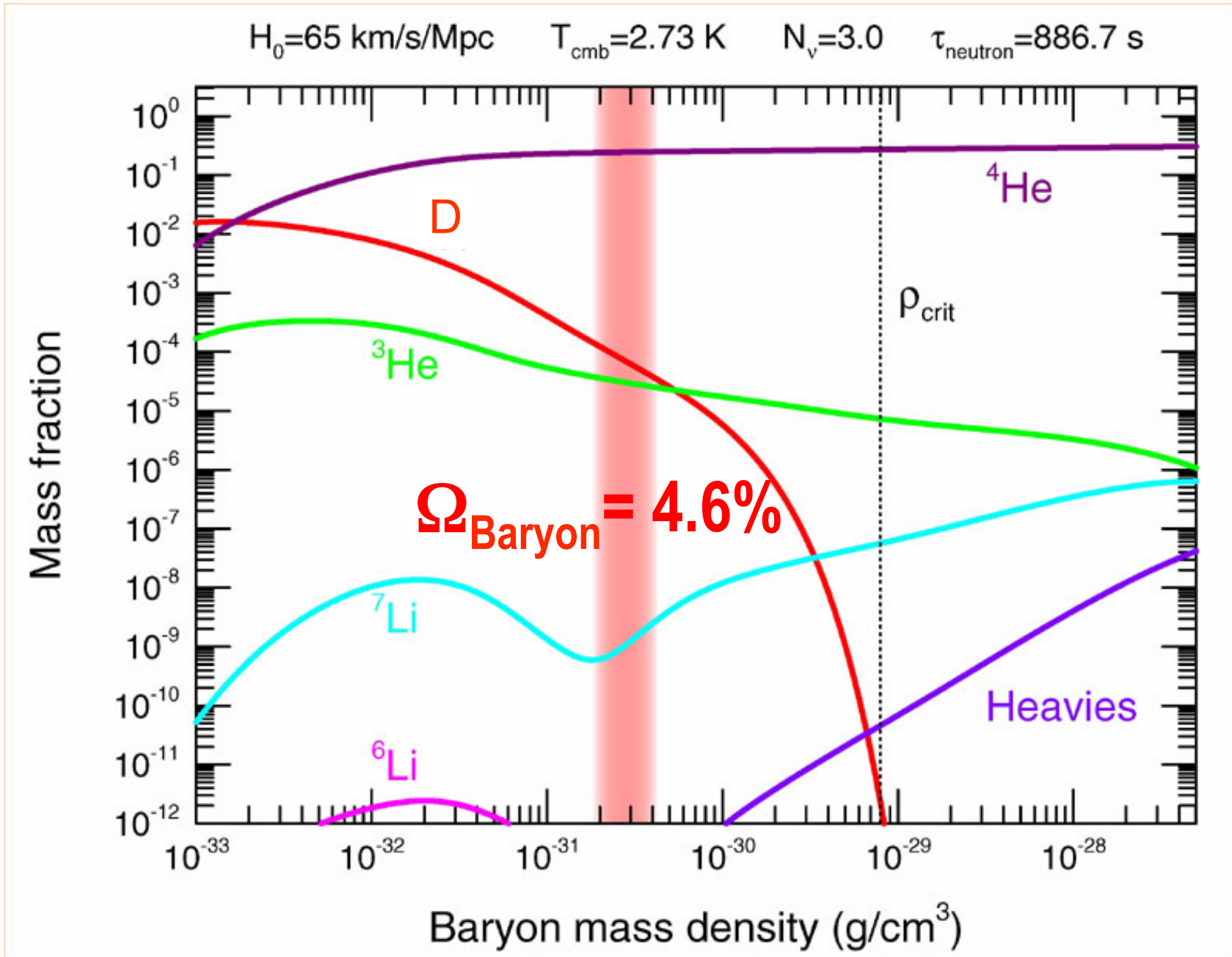

Cosmic Pyramid

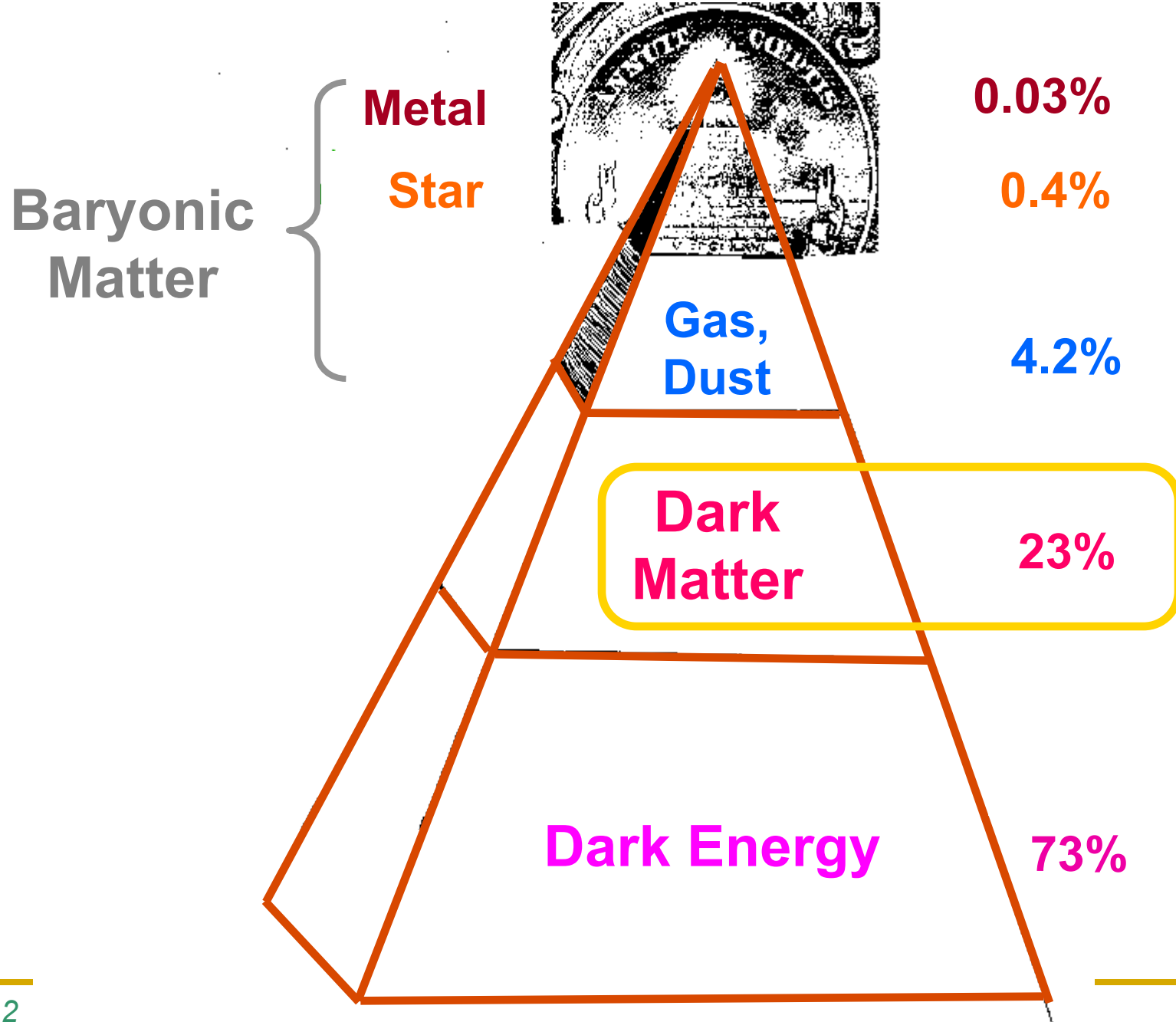

What is Dark Matter?

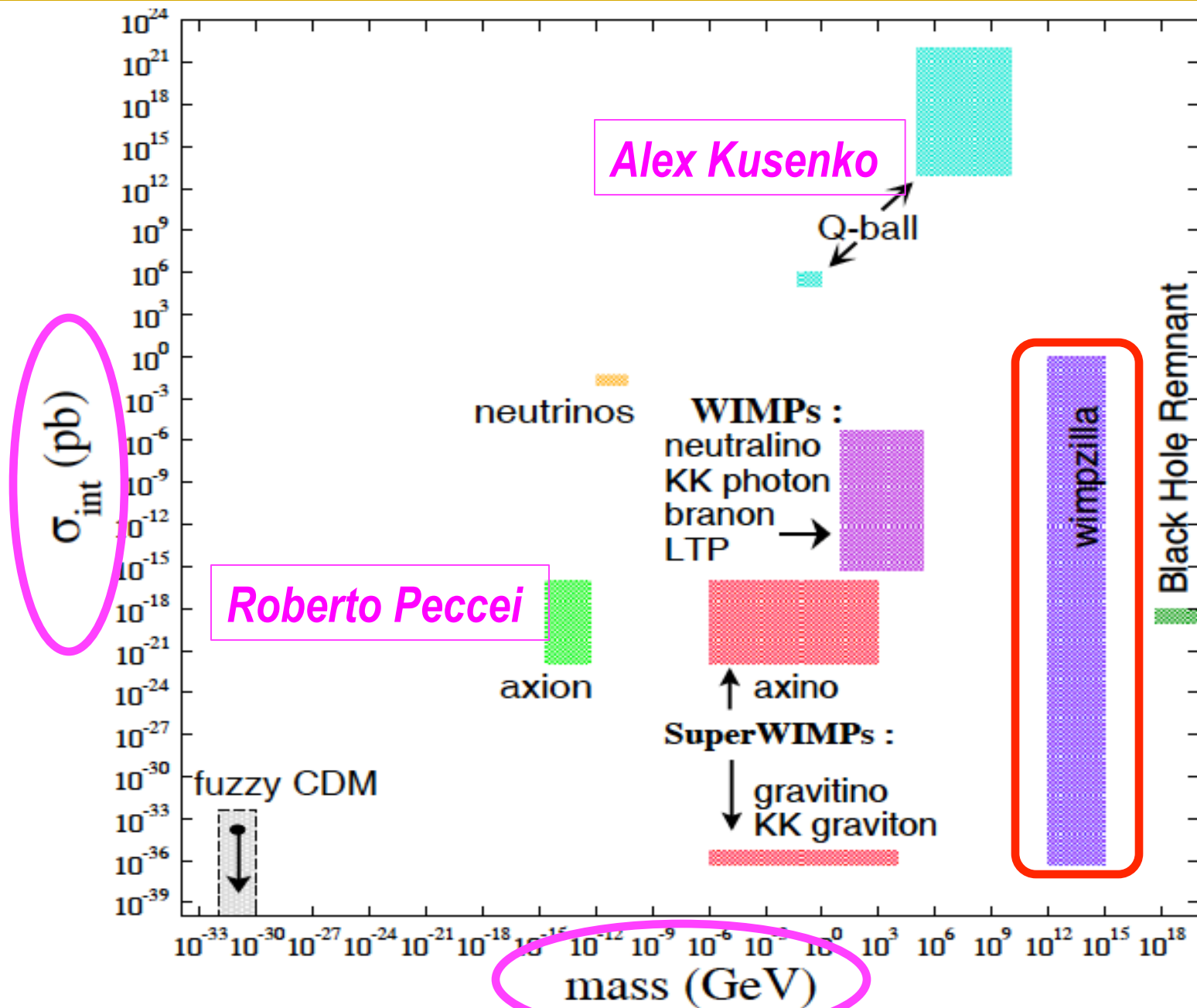

History of the Universe

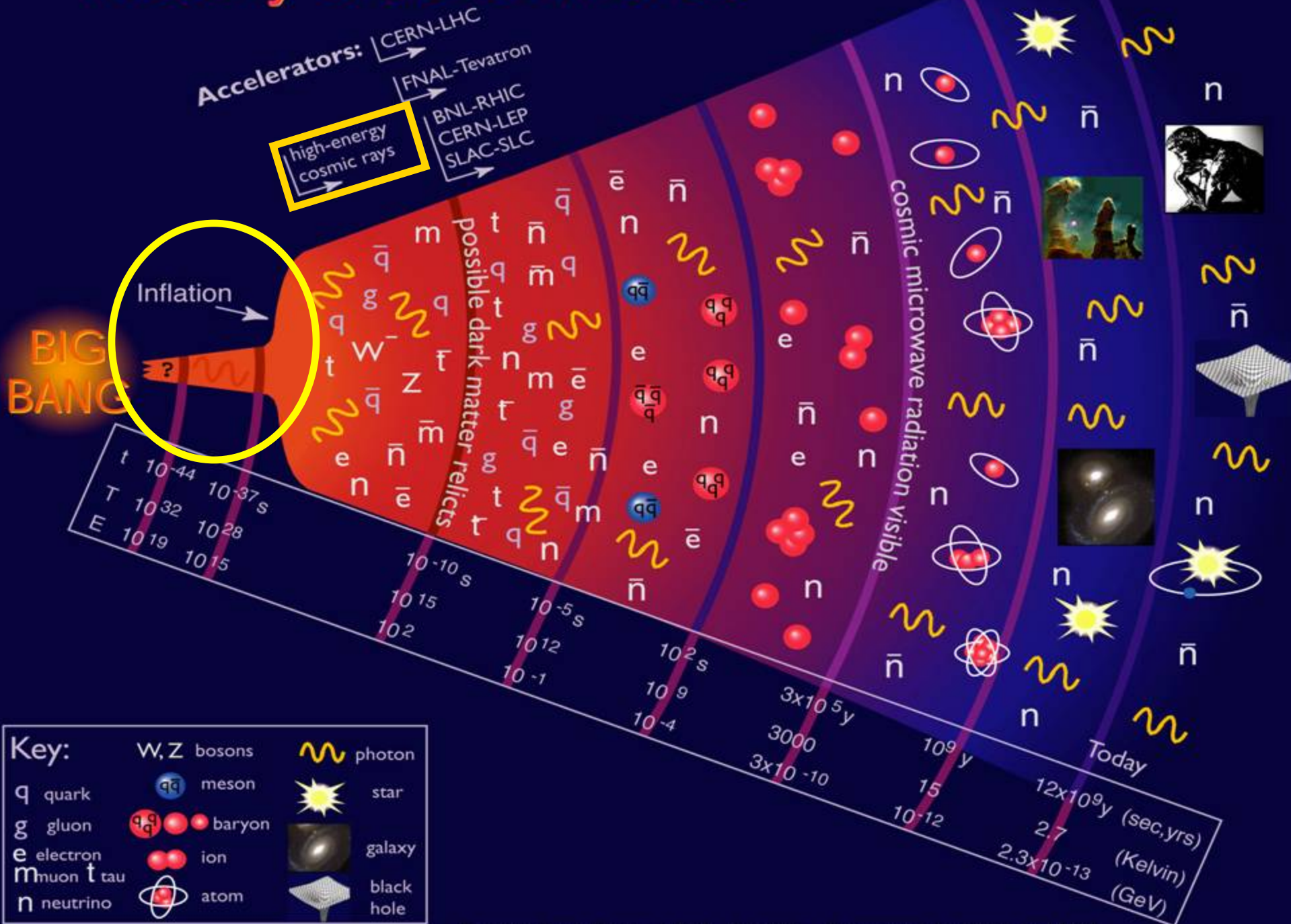

Energy Spectrum of Cosmic Rays

- Energy Spectrum $\sim E^{-3}$
- The spectrum extends beyond 10^{20}eV ($=10^{11} \text{GeV}$).
- Beyond 10^{20}eV , Flux is only one particle per km^2 -century.

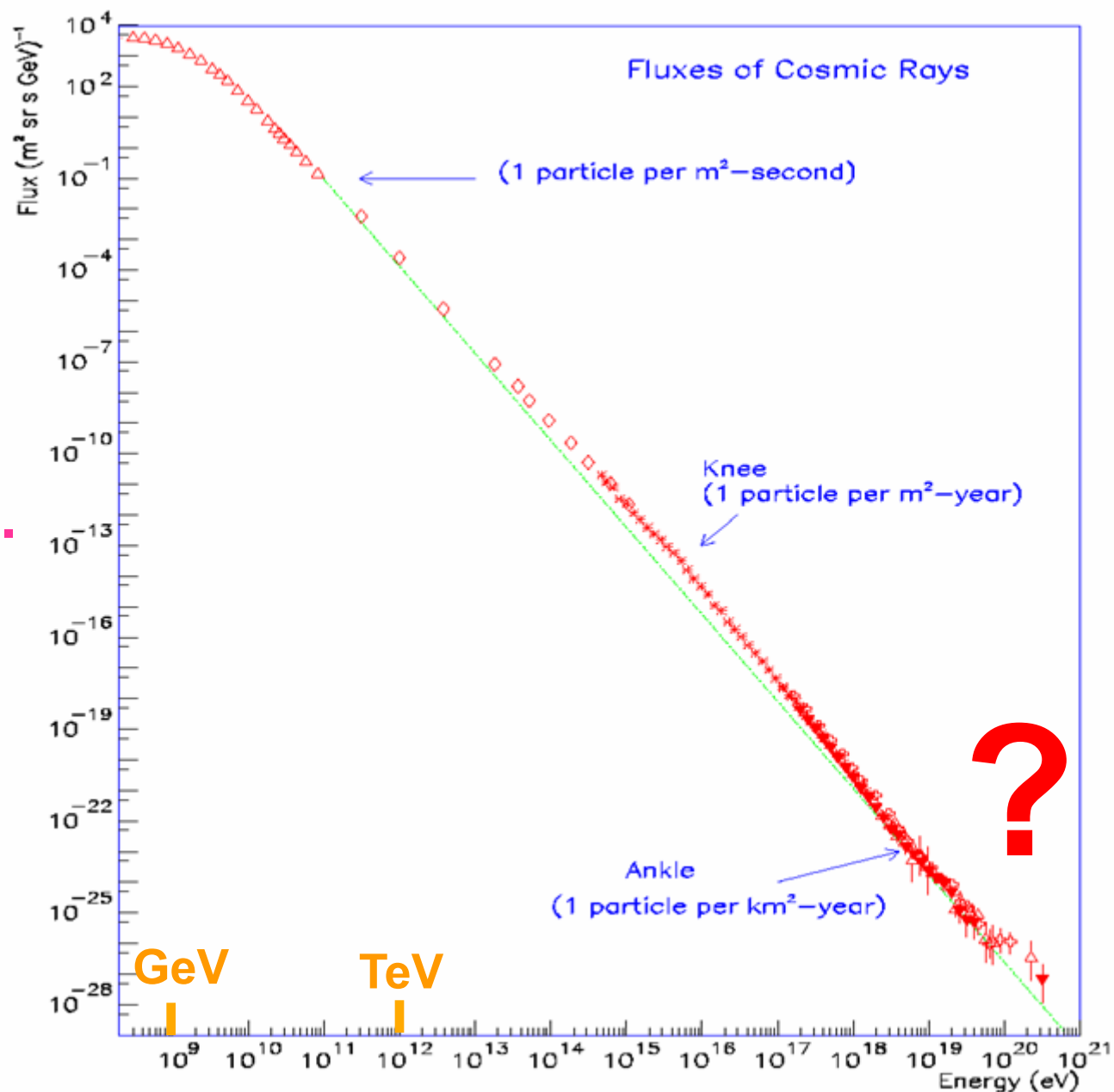

Arisaka on top of a water tank



Risetime vs. Log(E)

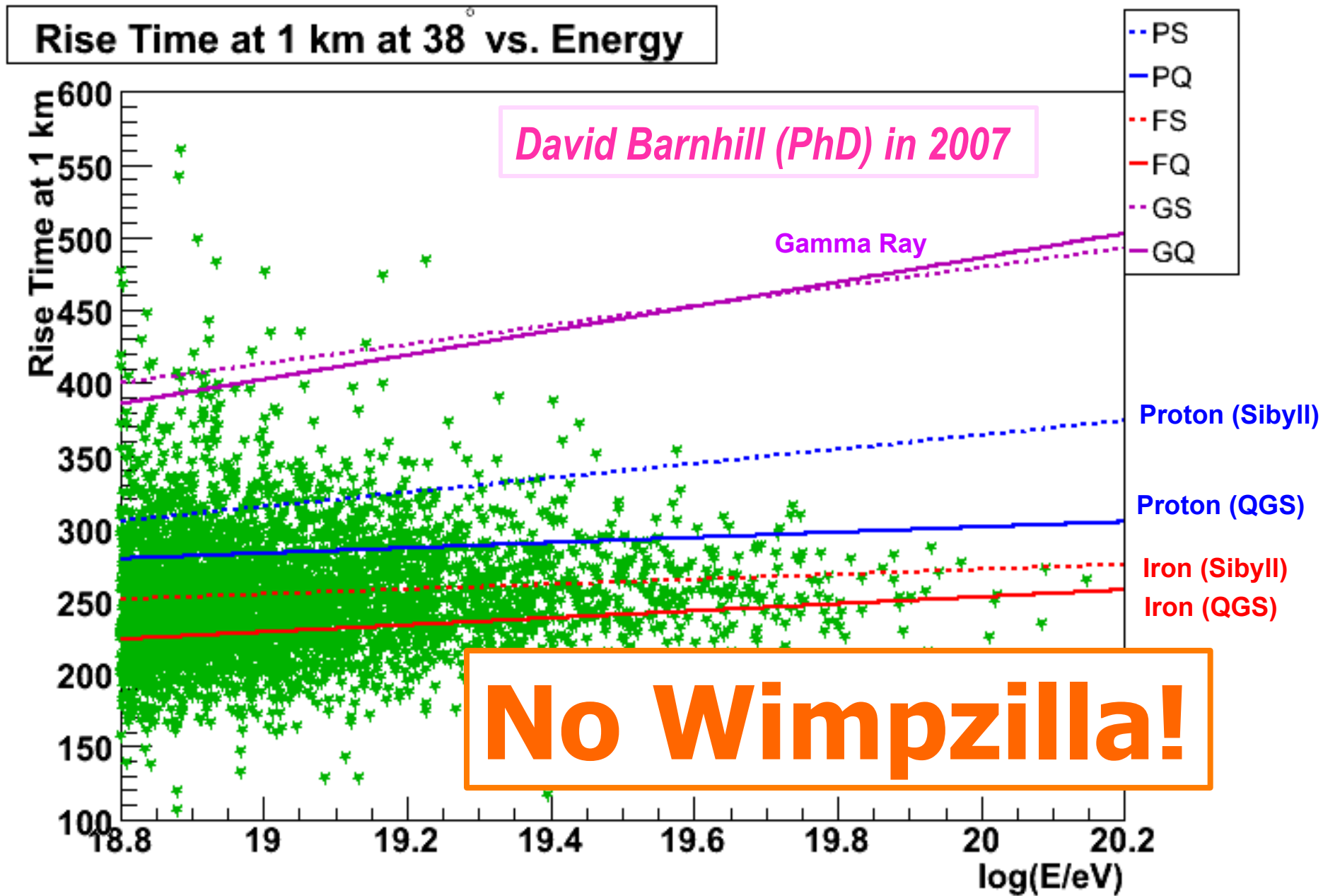

Symmetry Breaking

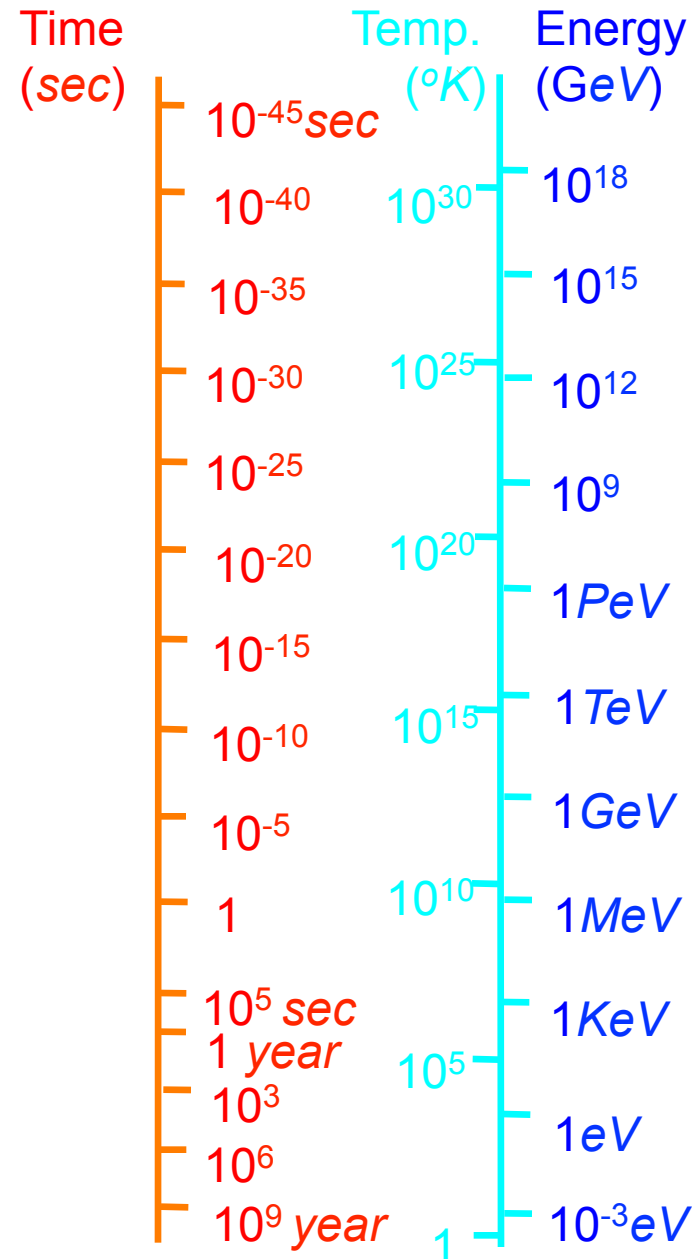

Simple

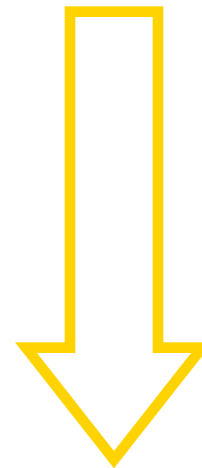

*Symmetry
Break Down*

Complex

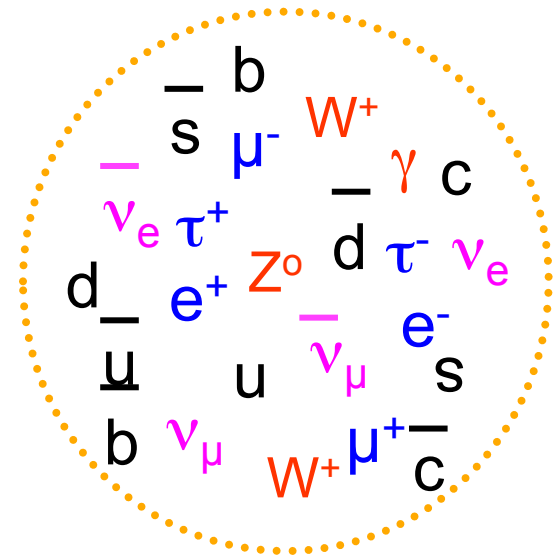

Mass of Particles (at $T = 0.1 \text{ ns}$)

Generation

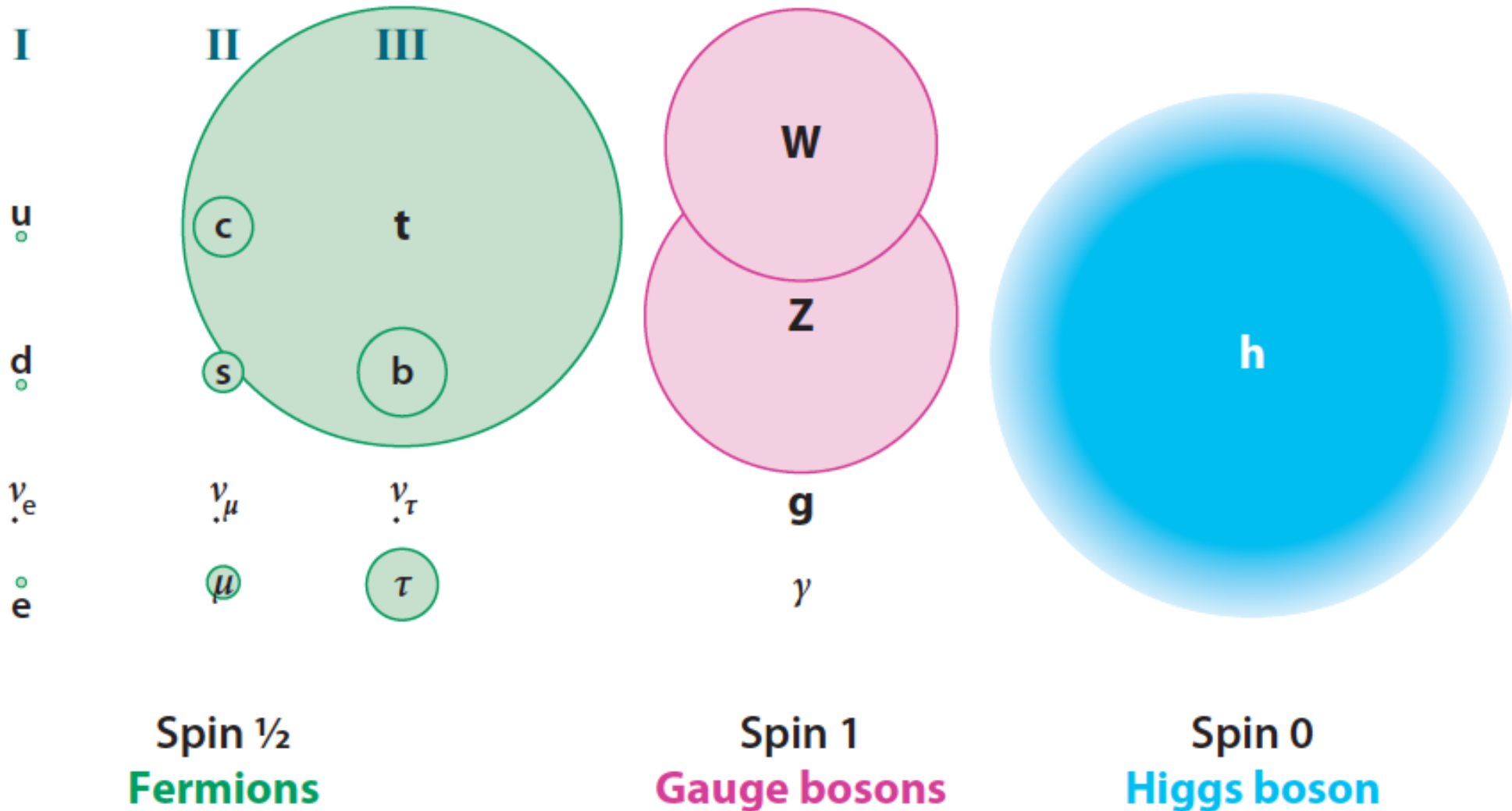

CERN and LHC in Geneva

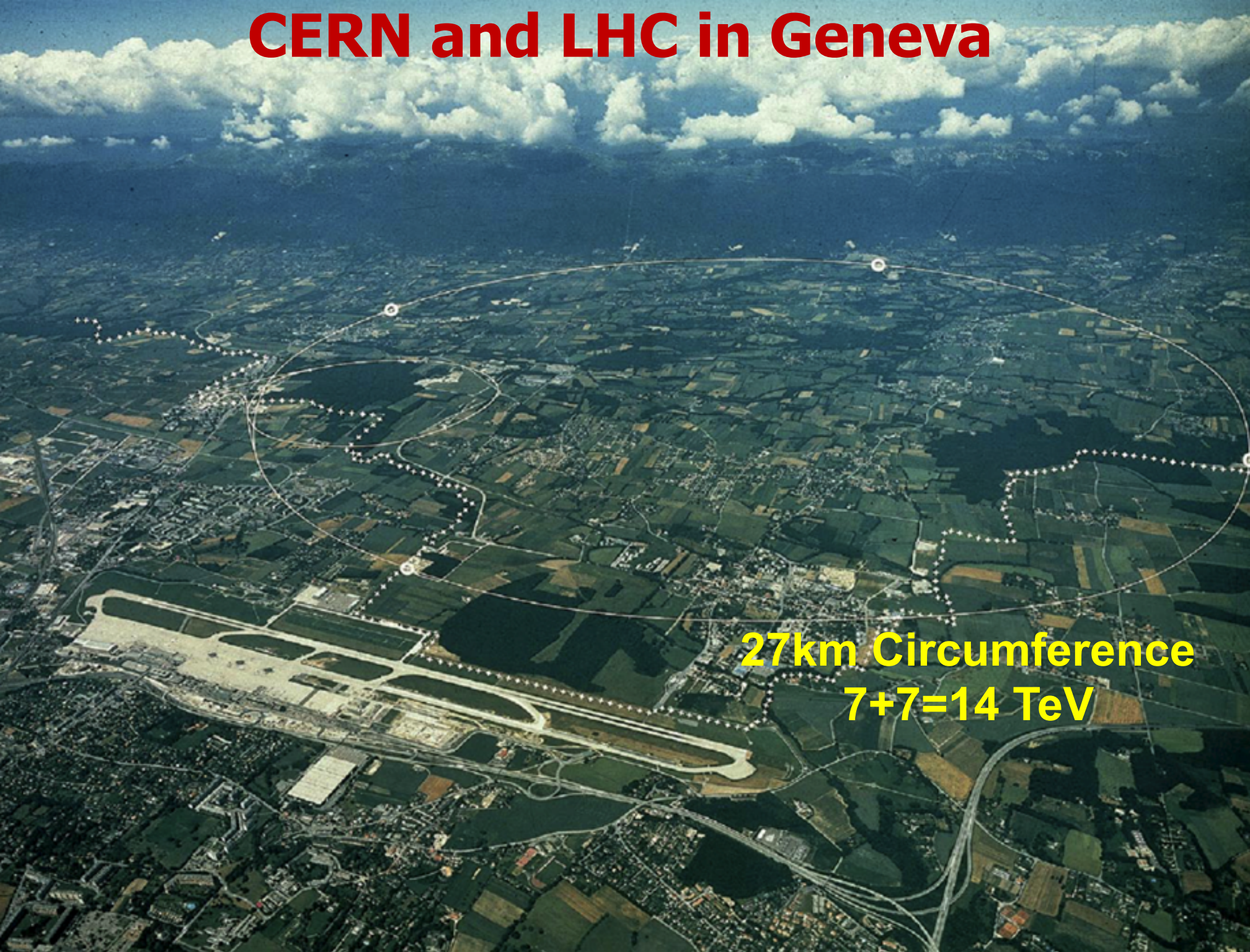

27km Circumference
7+7=14 TeV

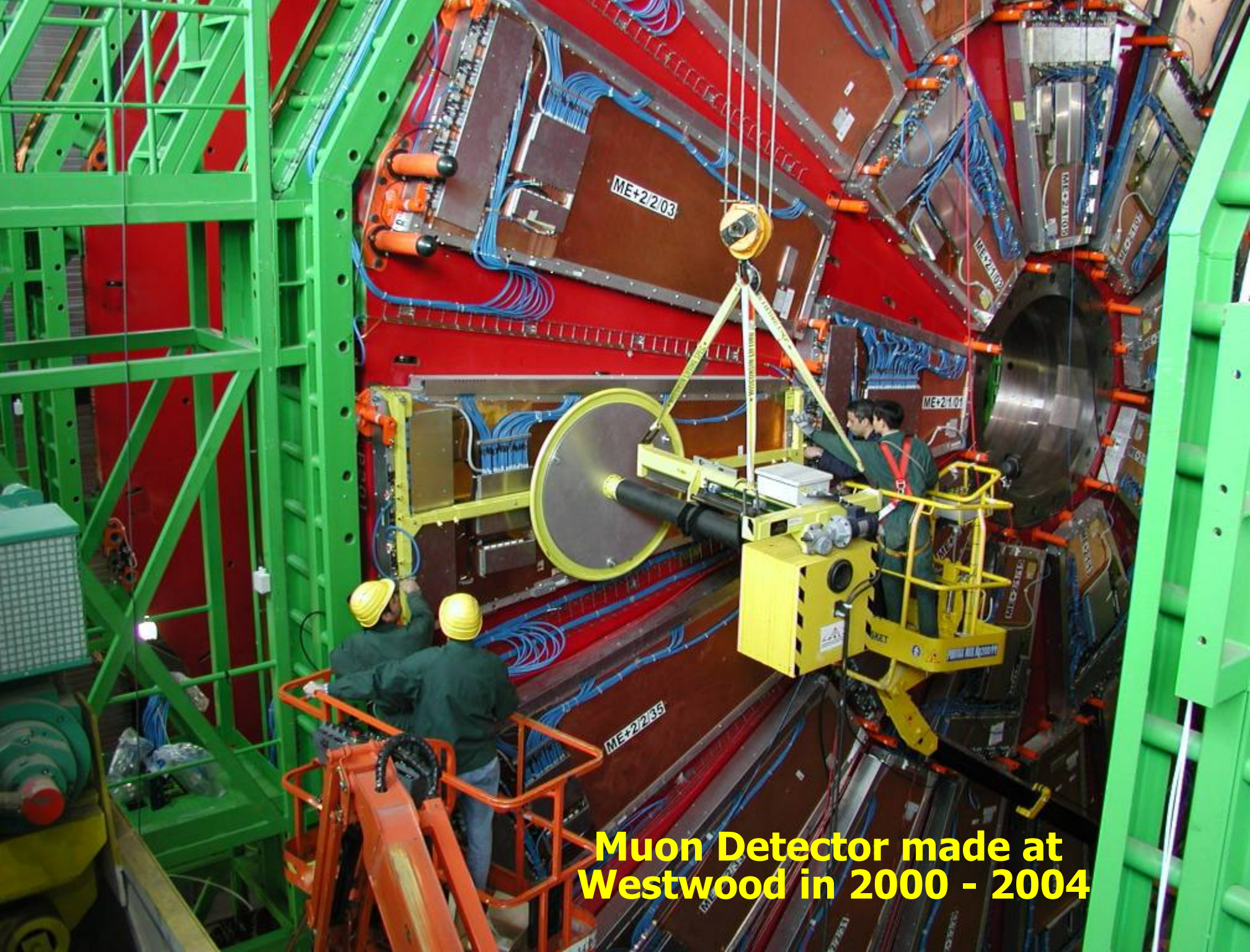

**Muon Detector made at
Westwood in 2000 - 2004**

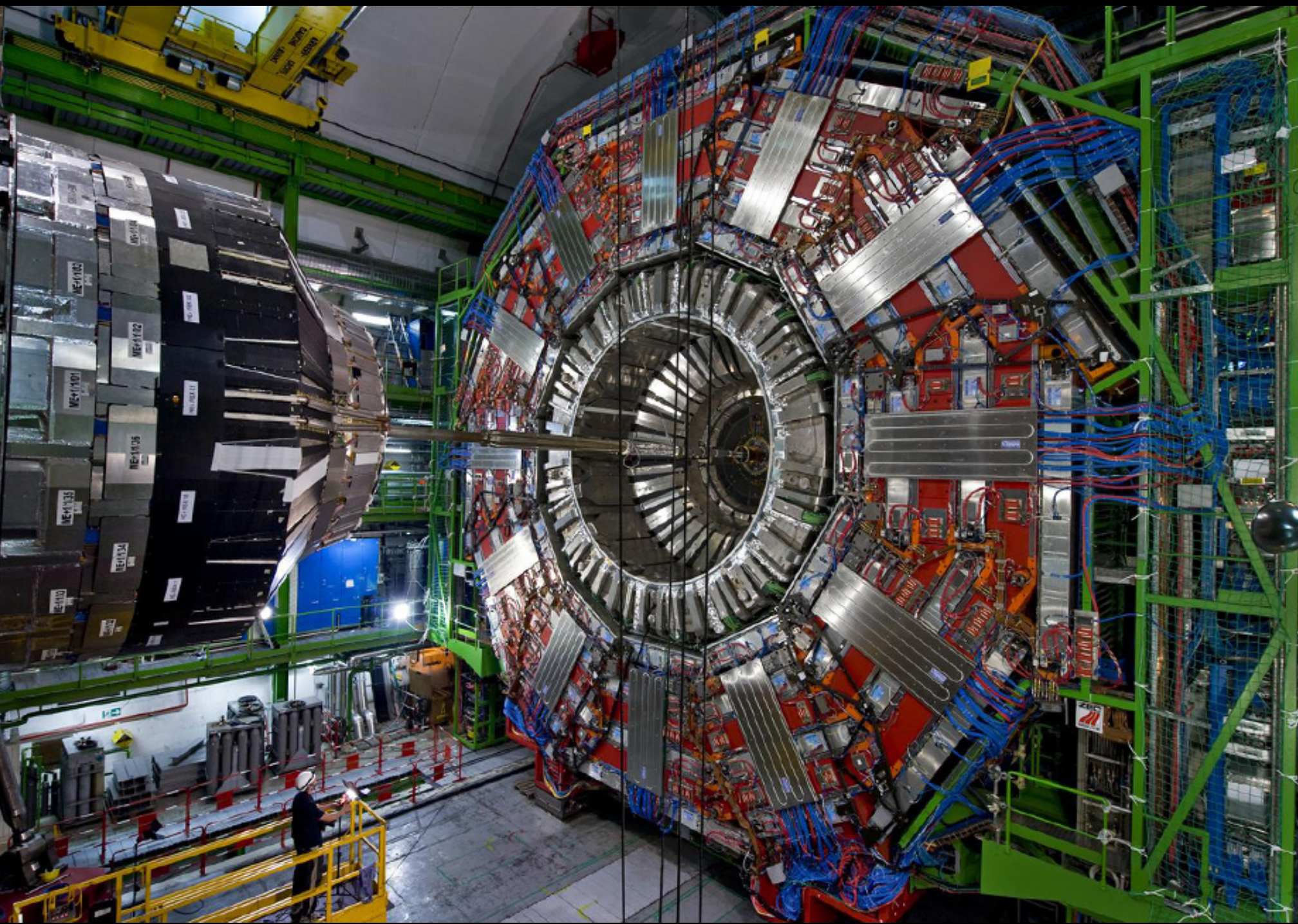

Higgs Discovery by CMS (July 4, 2012)

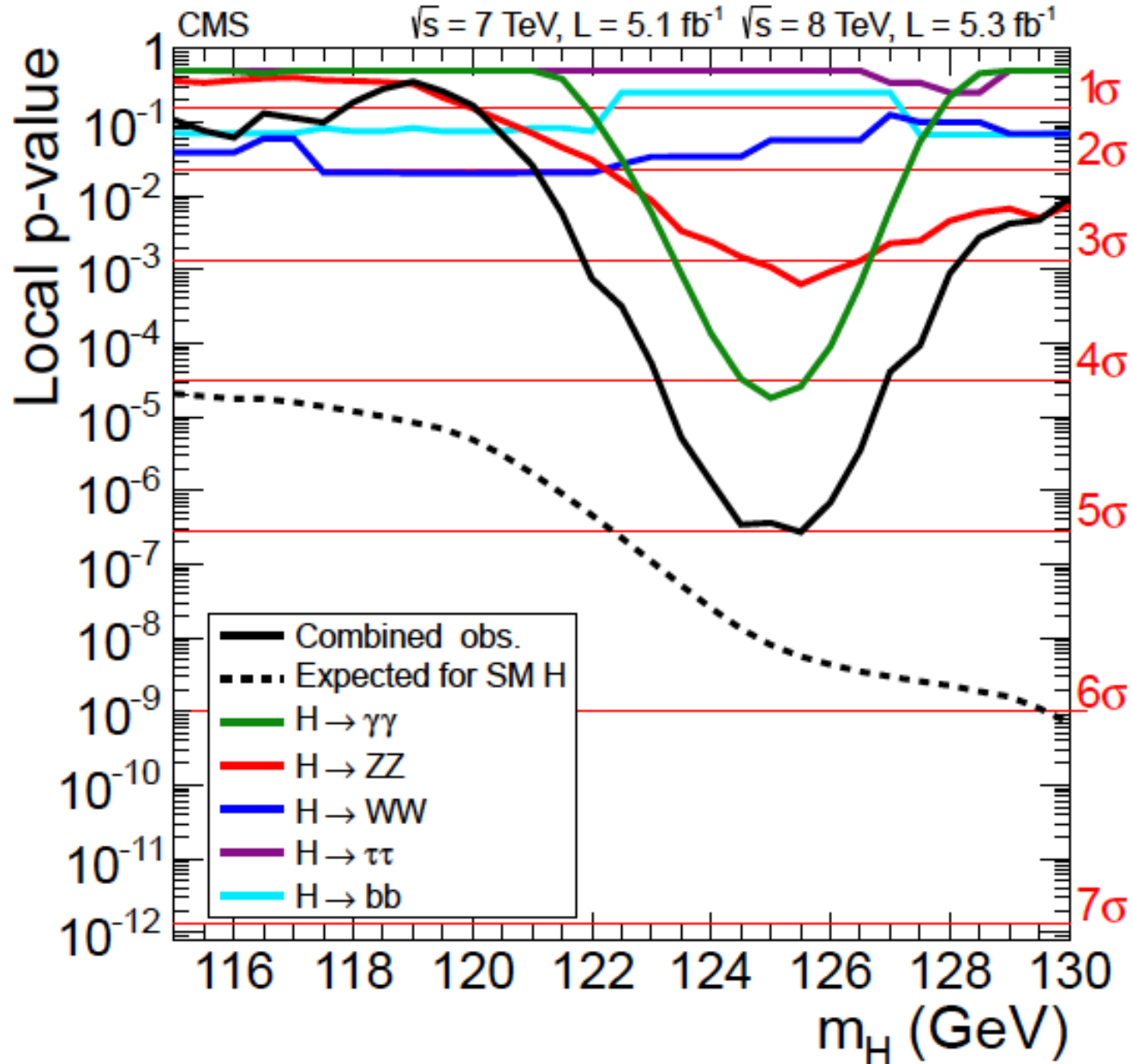

News release on July 4th !

Physicists Find Elusive Particle Seen as Key to Universe



So What's next, Bob?

Pool photo by Denis Balibouse

Scientists in Geneva on Wednesday applauded the discovery of a subatomic particle that looks like the Higgs boson.

By DENNIS OVERBYE

Published: July 4, 2012 |  122 Comments

SUSY Neutralino

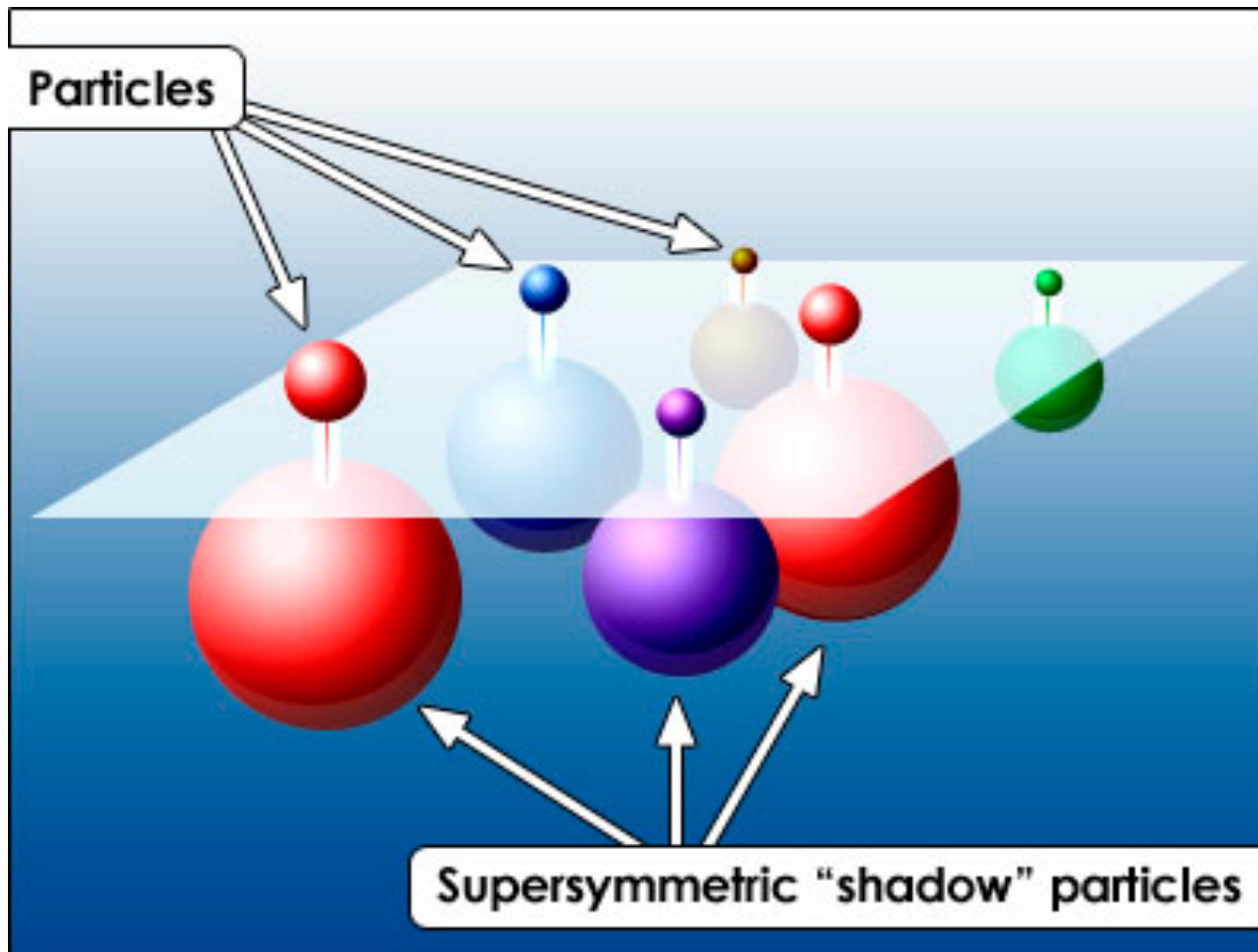

SUSY Particles and Neutralino

Standard particles

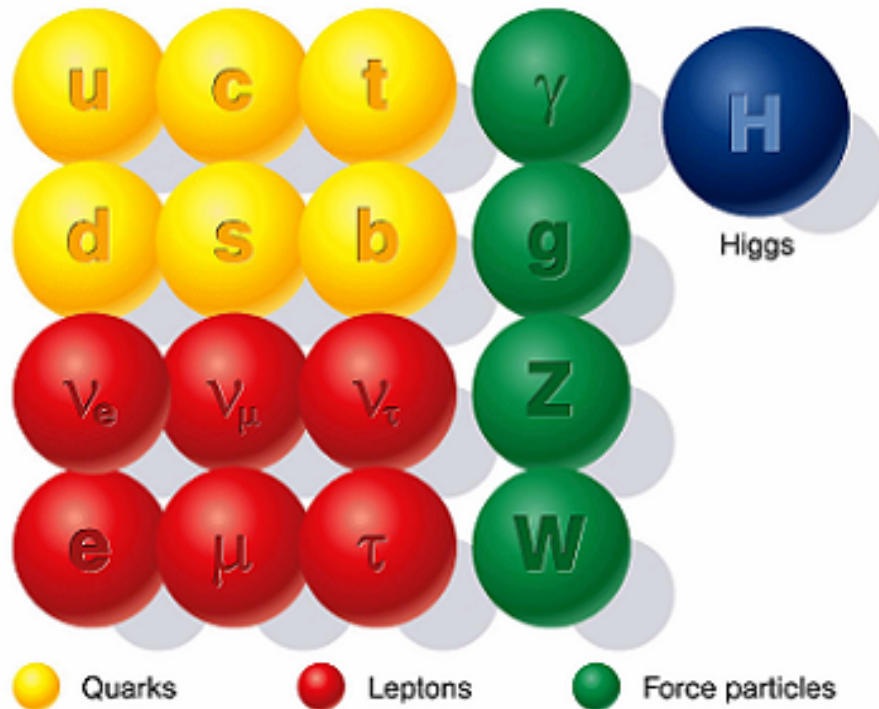

Spin 1/2 1 0

SUSY Particles and Neutralino

Super Symmetry

Neutralino

Standard particles

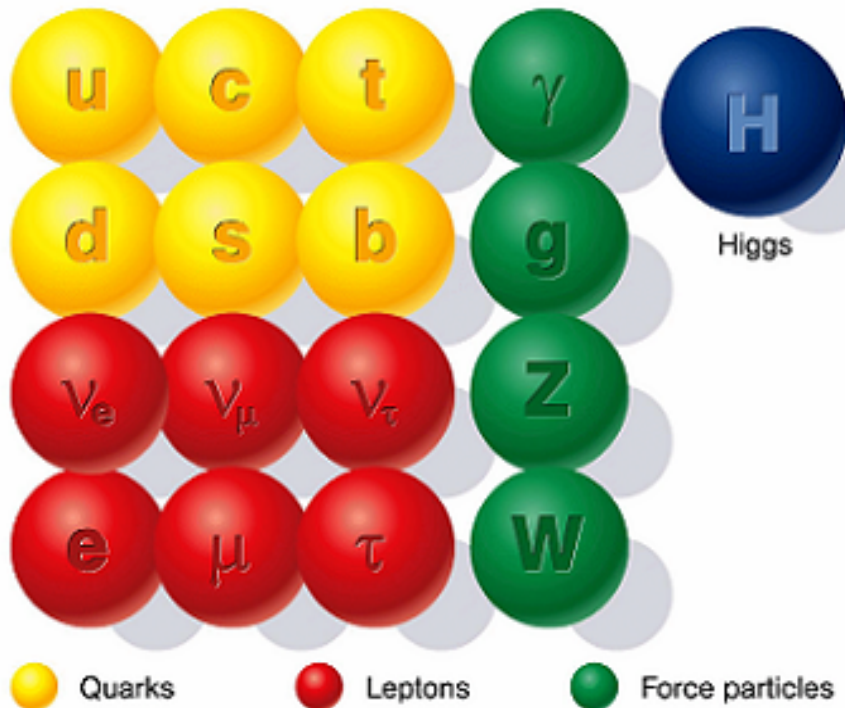

SUSY particles

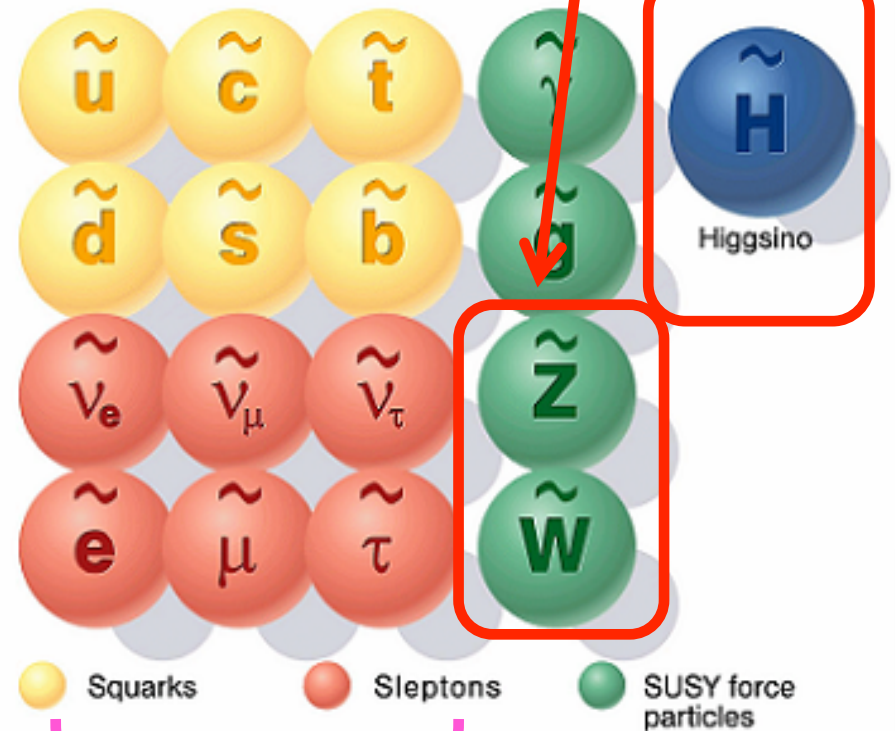

Spin 1/2 1 0 0 1/2 1/2

Hierarchy Problem

Higgs mass

$m_b^2 = m_{b0}^2 + \Delta m_b^2$, where m_{b0}^2 is the tree-level mass, and

SM :
$$\Delta m_b^2 \sim \frac{\lambda^2}{16\pi^2} \int^\Lambda \frac{d^4 p}{p^2} \sim \frac{\lambda^2}{16\pi^2} \Lambda^2$$

SUSY :
$$\Delta m_b^2 \sim \frac{\lambda^2}{16\pi^2} \int^\Lambda \frac{d^4 p}{p^2} \Big|_{\text{SM}} - \frac{\lambda^2}{16\pi^2} \int^\Lambda \frac{d^4 p}{p^2} \Big|_{\text{SUSY}}$$

$$\sim \frac{\lambda^2}{16\pi^2} (m_{\text{SUSY}}^2 - m_{\text{SM}}^2) \ln \frac{\Lambda}{m_{\text{SUSY}}}$$

or : new physics at the energy scale of $\Lambda \sim 1 \text{ TeV}$

Unification of Coupling Constants

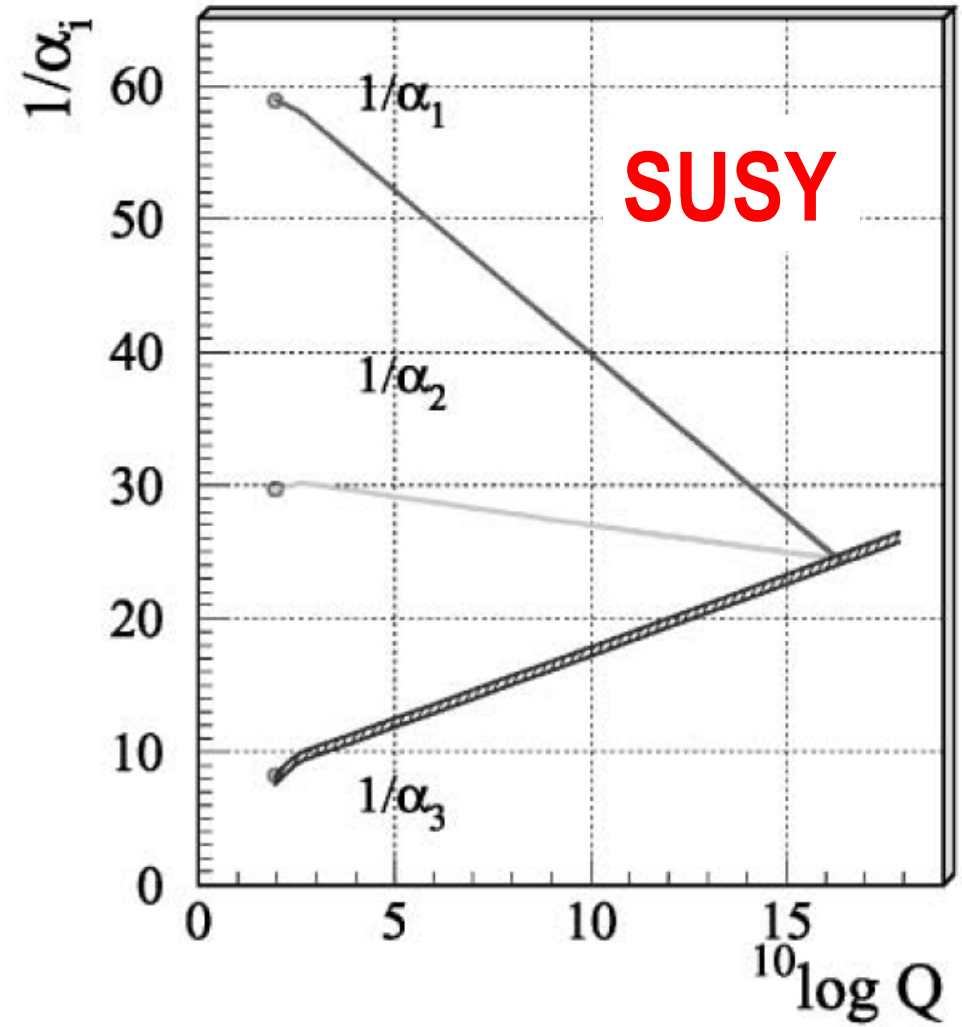
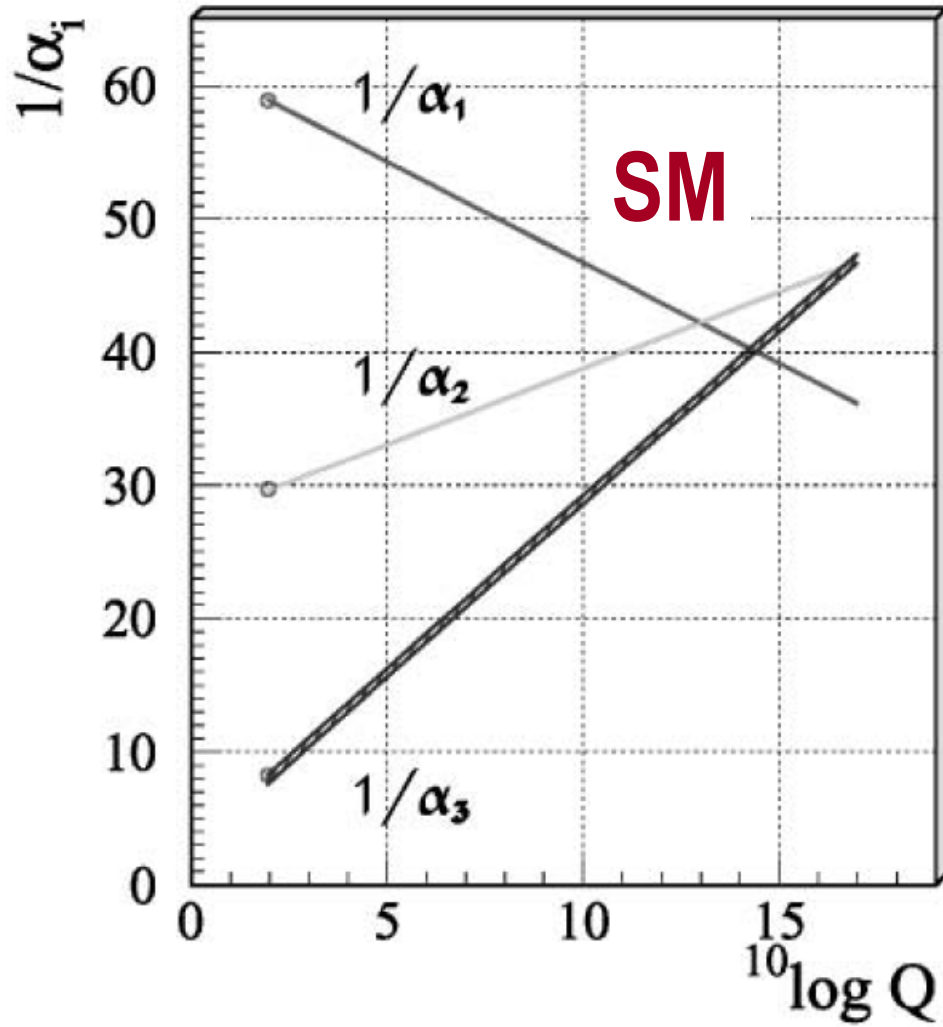

What is Dark Matter?

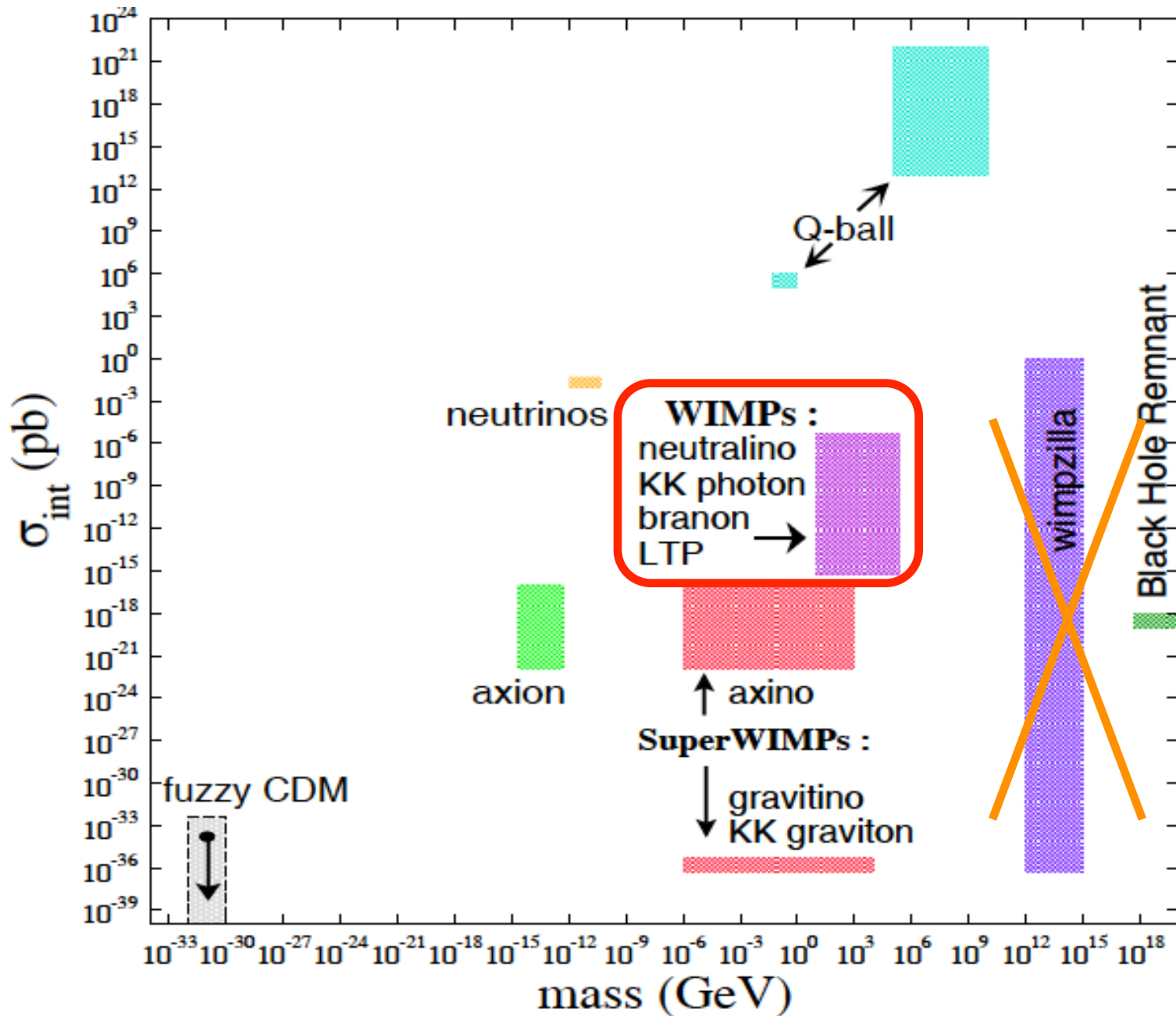

Three Detection Methods

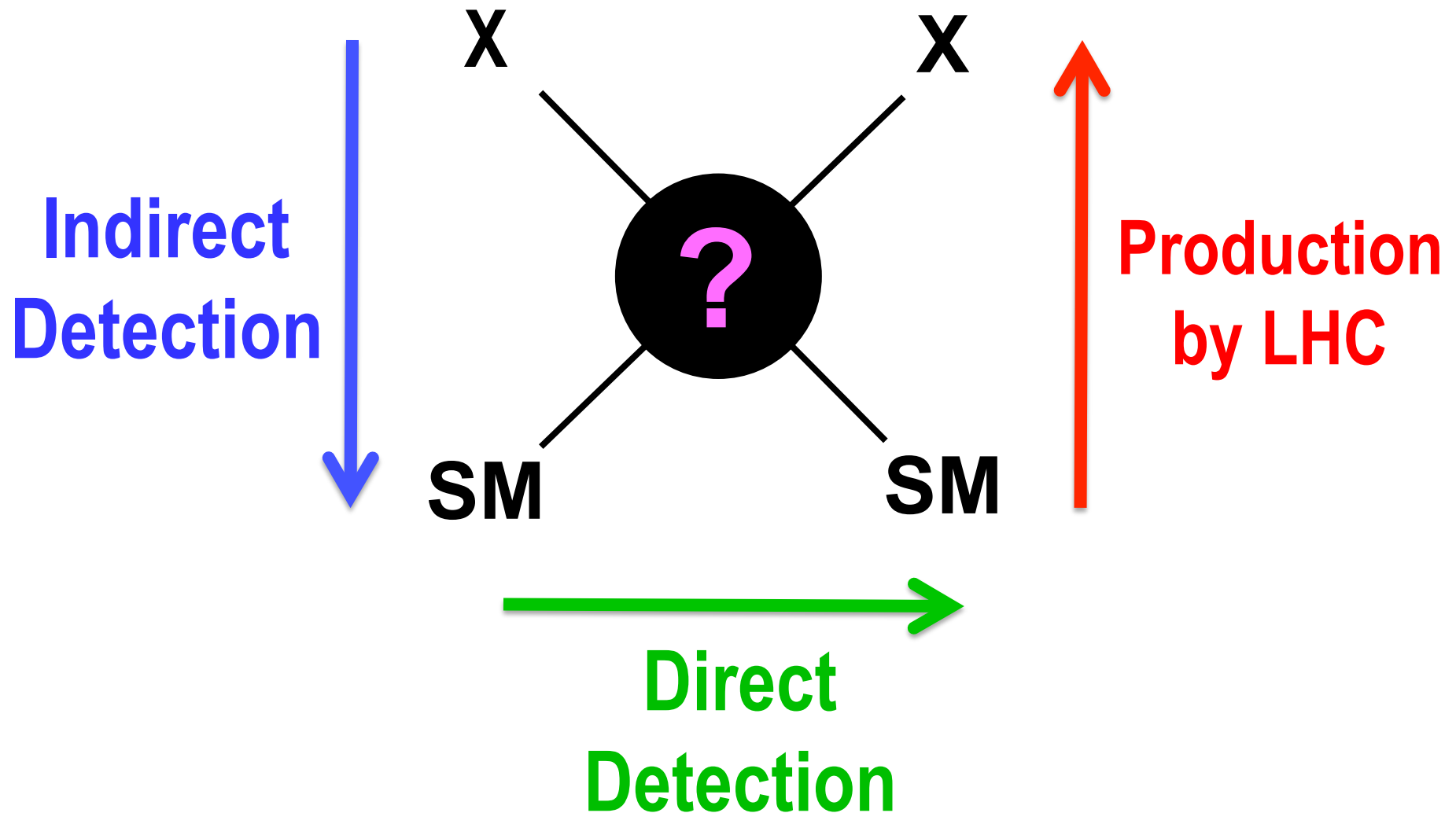

MSSM: > 100 parameters

Minimal Flavour Violation: 13 parameters
(+ 6 violating CP)

SU(5) unification: 7 parameters

NUHM2: 6 parameters

NUHM1 = SO(10): 5 parameters

CMSSM: 4 parameters

mSUGRA: 3
parameters

String?

mSUGRA $m_{1/2}$ vs. m_0 (before LHC)

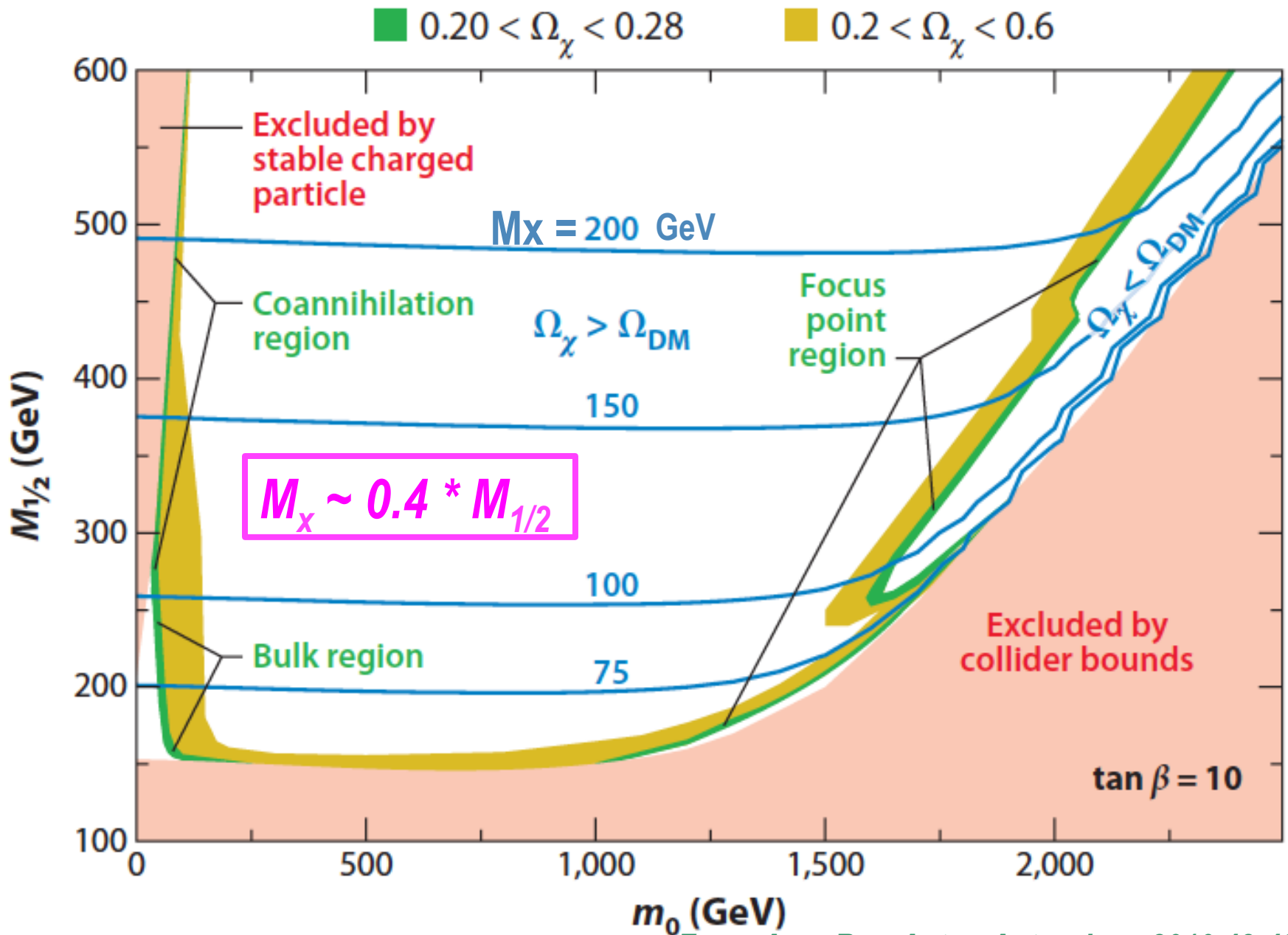

Feng *Ann. Rev. Astro. Astrophys.* 2010.48:495-545

New CMS Results

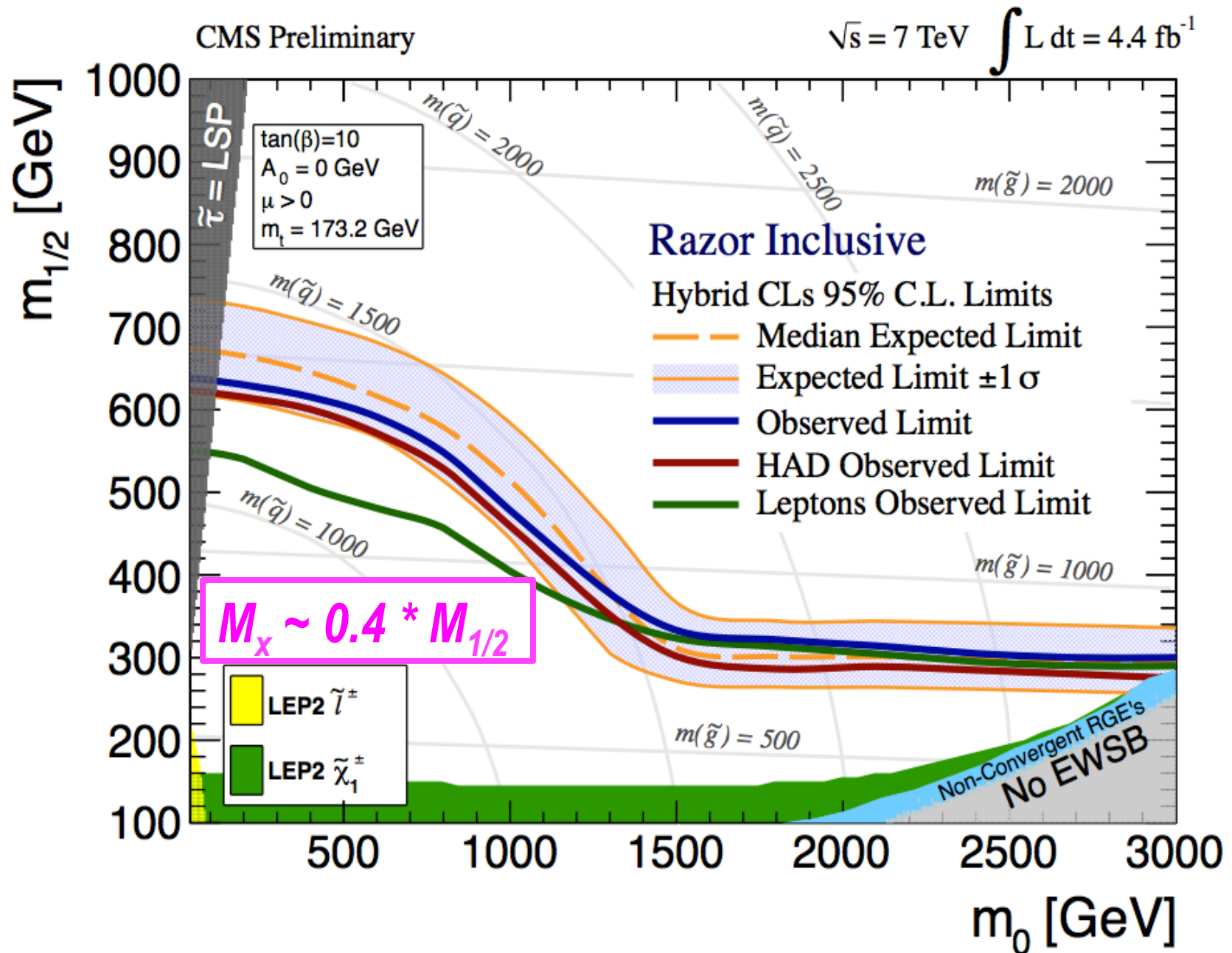

SI Cross Section vs. Mass

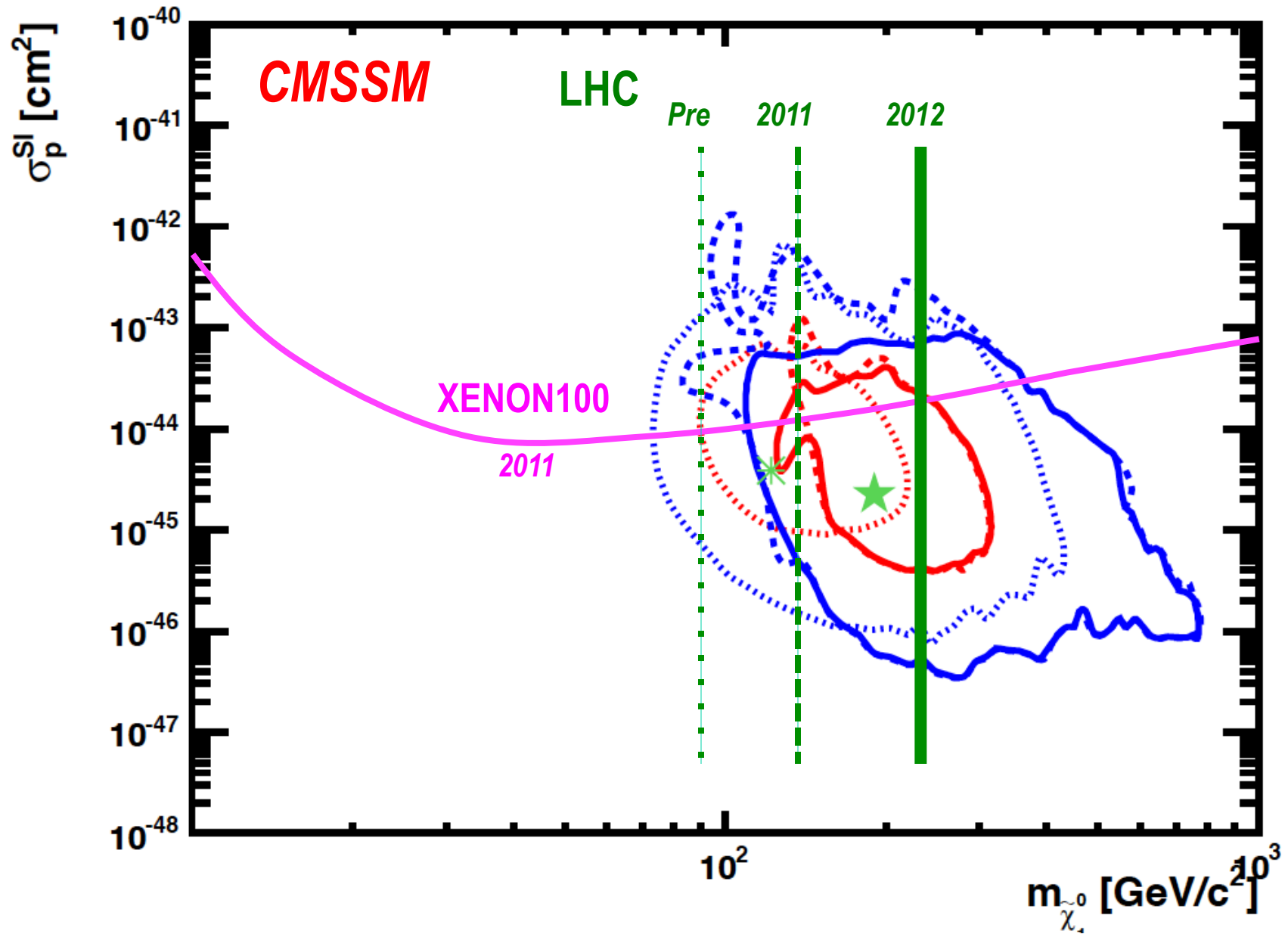

Buchmueller et al [arXiv:1106.2529](https://arxiv.org/abs/1106.2529)

Three Detection Methods

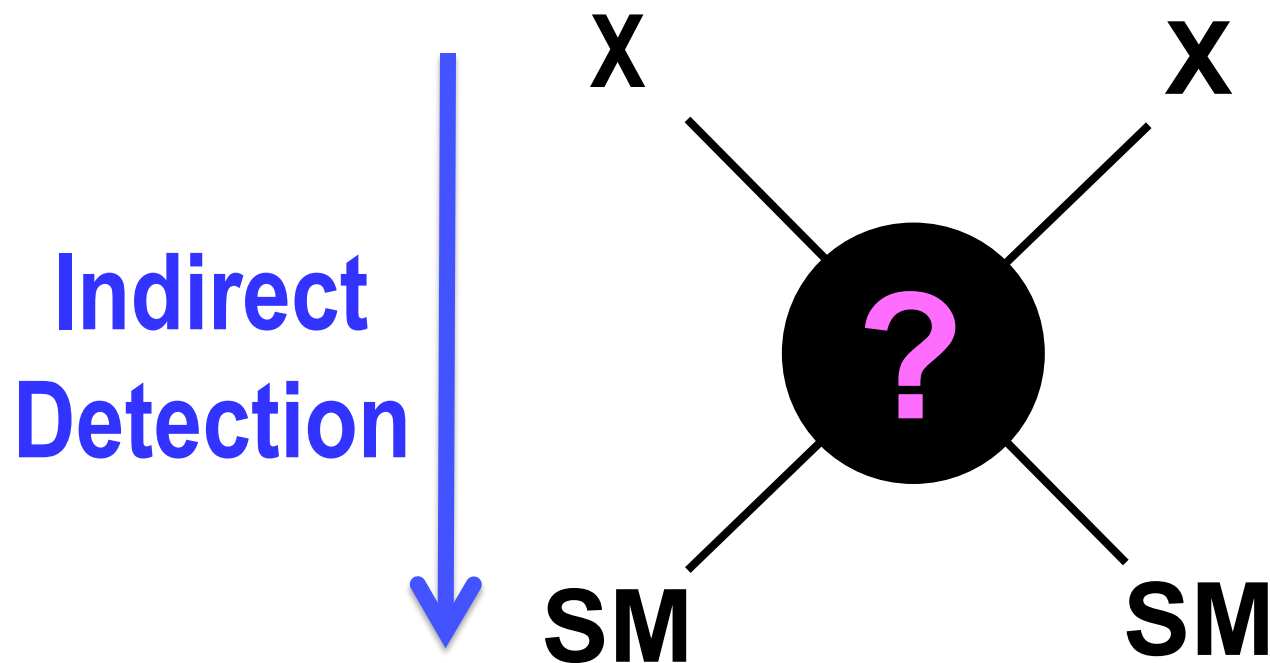

Indirect Detection

Rene Ong

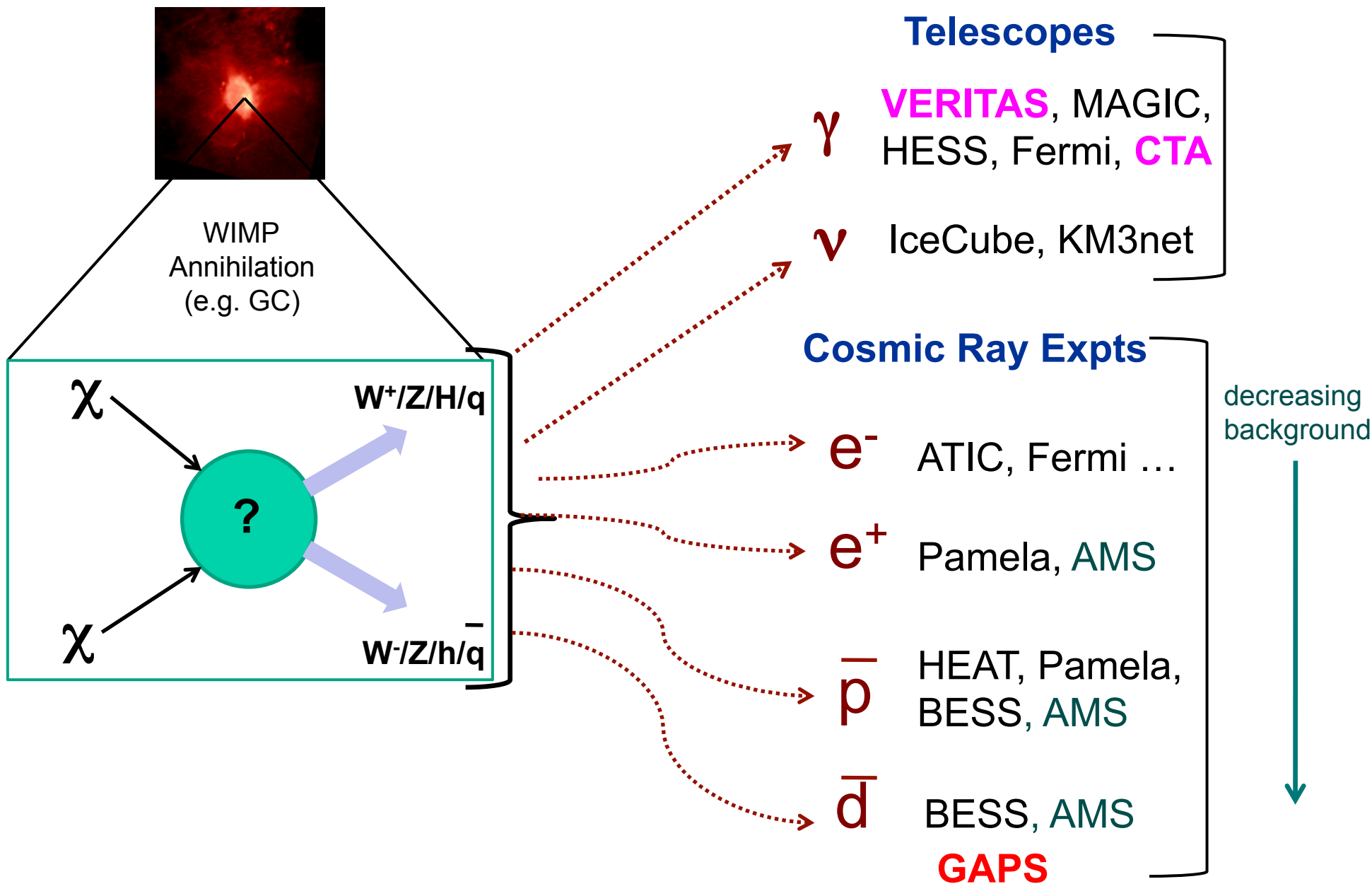

Gamma Ray Telescopes

Rene Ong & Vladimir Vassiliev



Fermi-LAT (Fermi Large Area Telescope)



H.E.S.S. & H.E.S.S.-2



VERITAS

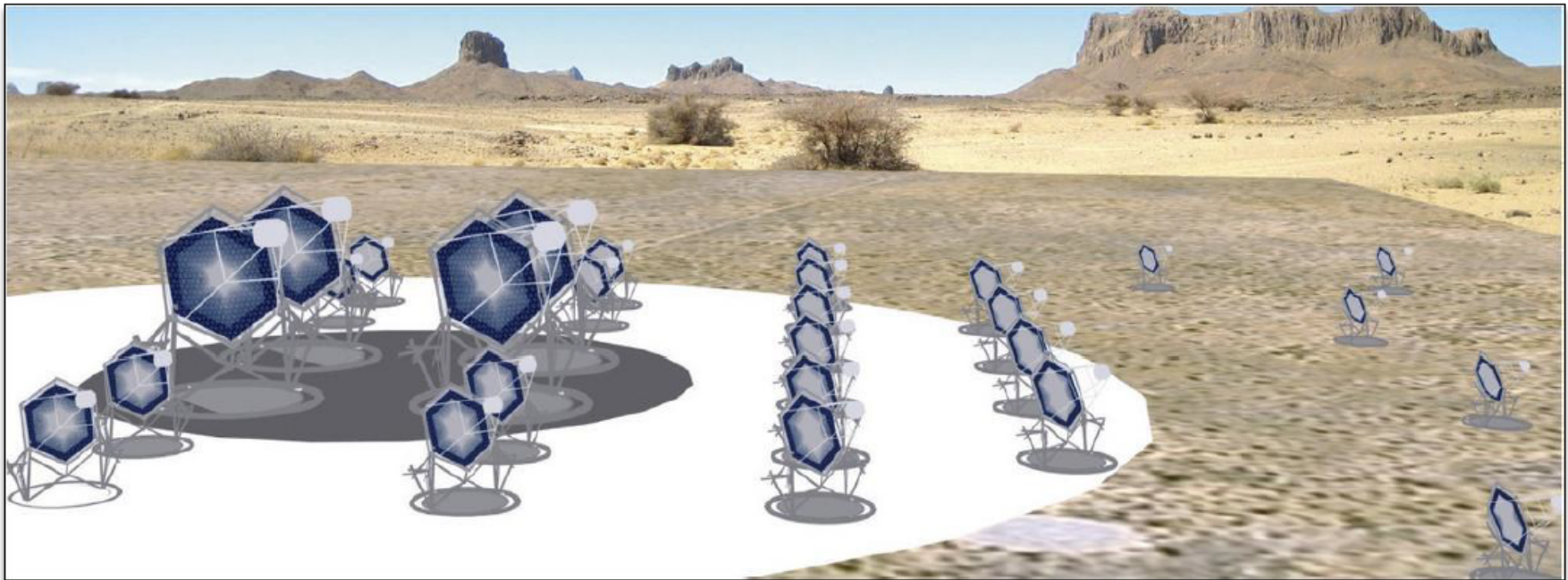

CTA (Cherenkov Telescope Array)

130 GeV Peak by FERMI

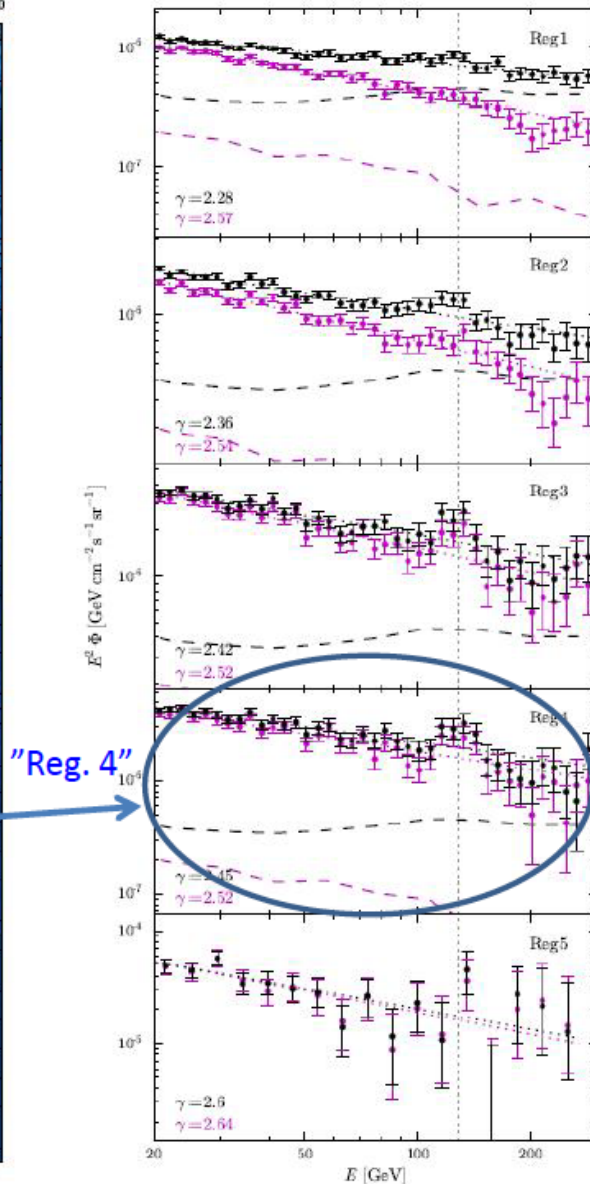
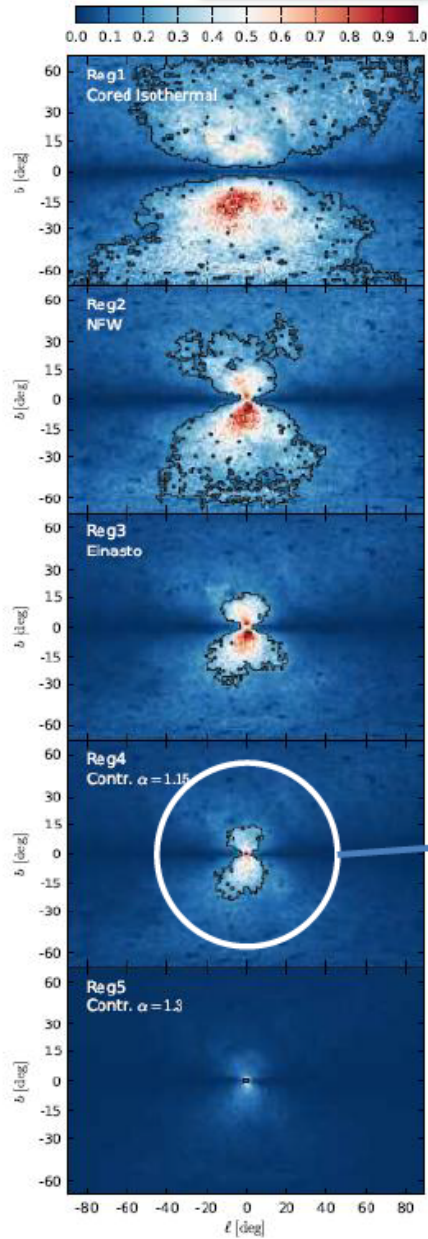

43 months of (public) Fermi data

γ -ray line fit:

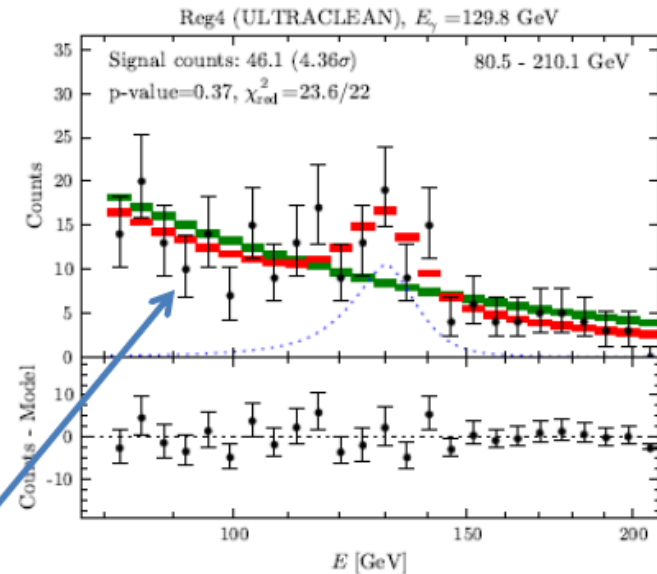

Mass = 130 GeV
 Significance 4.6σ (3.3σ if "look elsewhere" effect included)
 See also E. Tempel, A. Hektor & M. Raidal, arXiv:1205.1045;
 M. Su & D. Finkbeiner, arXiv:1206.1616.

AMS-2

TRD
Identify e^+ , e^-

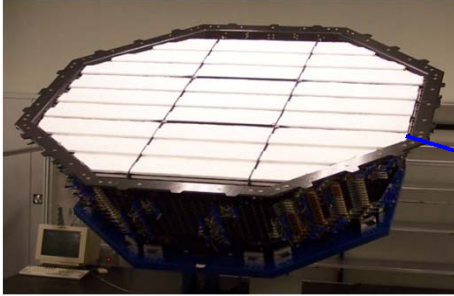

Particles and nuclei are defined by their charge (Z) and energy ($E \sim P$)

TOF
 Z, E



Silicon Tracker
 Z, P

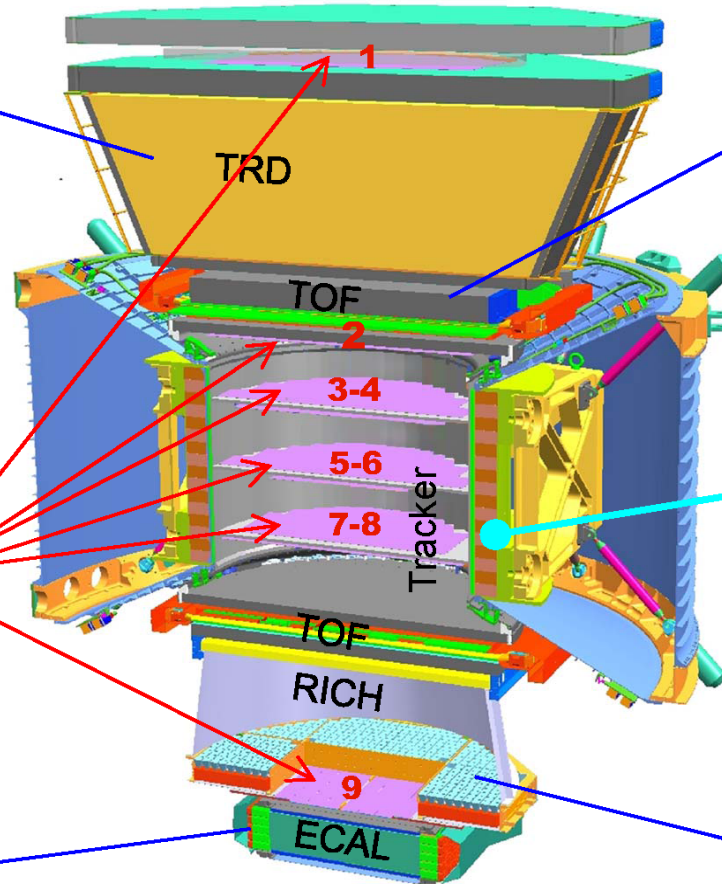

Magnet
 $\pm Z$

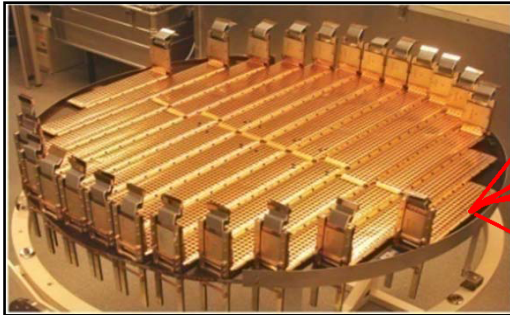
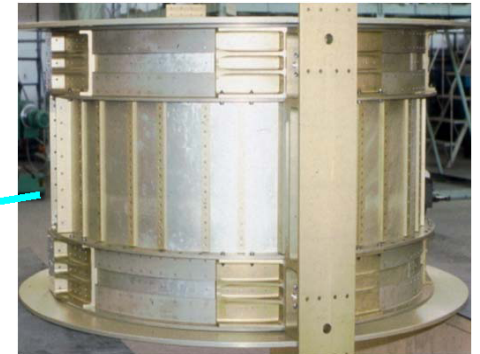

ECAL
 E of e^+ , e^- , γ

RICH
 Z, E

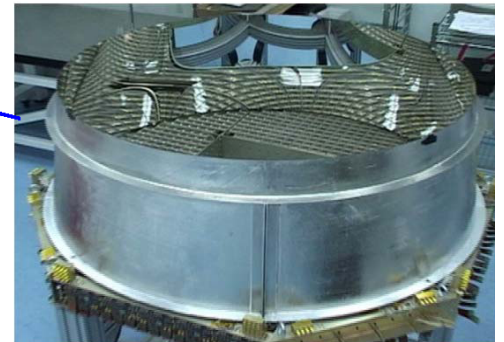

Z, P are measured independently from Tracker, RICH, TOF and ECAL

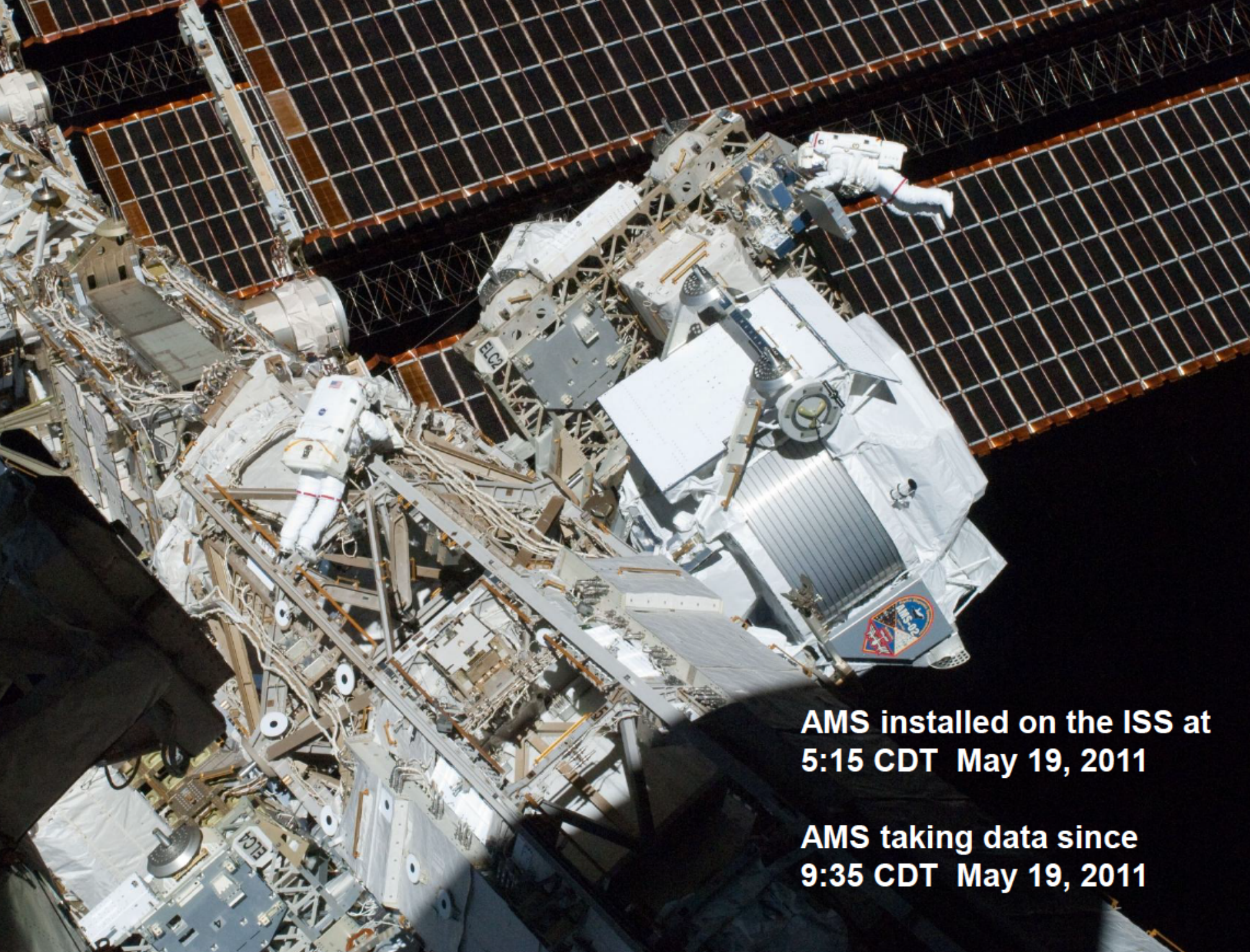

**AMS installed on the ISS at
5:15 CDT May 19, 2011**

**AMS taking data since
9:35 CDT May 19, 2011**

Successful Balloon Flight of pGAPS (June 3, Taiki Japan)

Rene Ong



Recovery

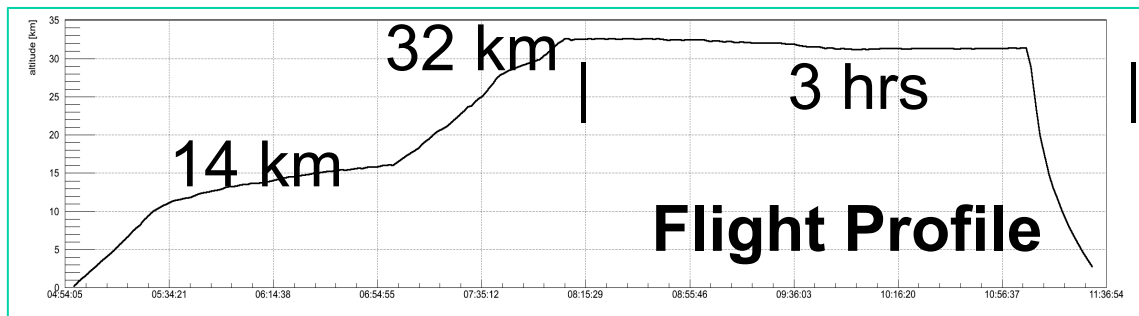

Three Detection Methods

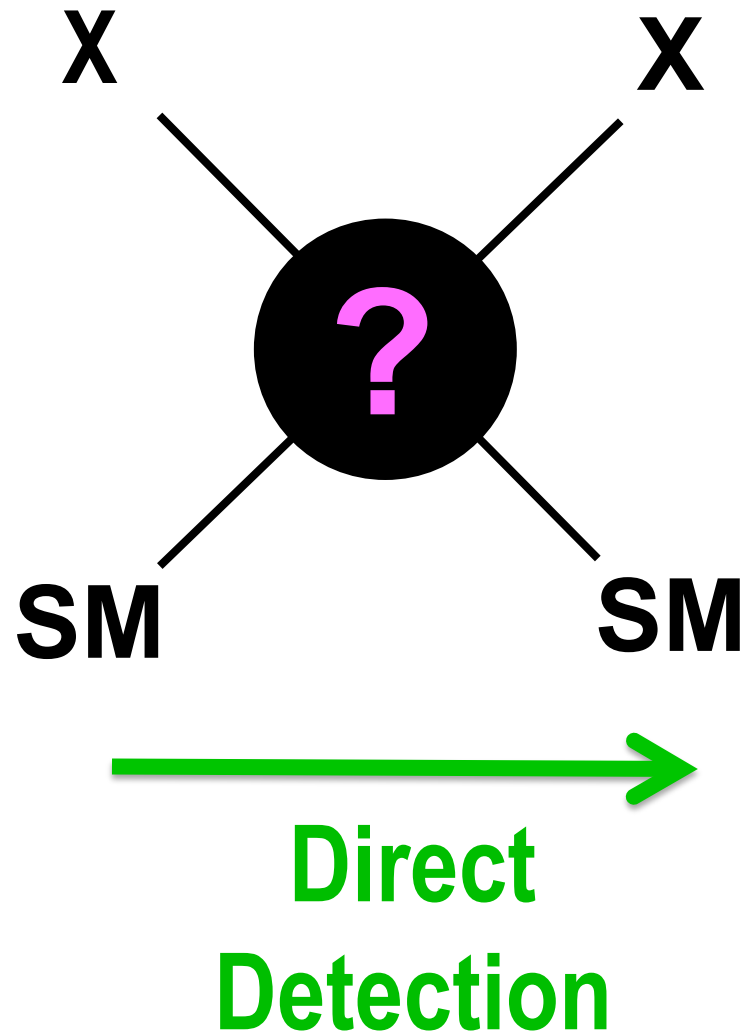

Target Mass Dependence of WIMP Cross Section

cross section 10^{-44} cm^2 , WIMP mass 100 GeV

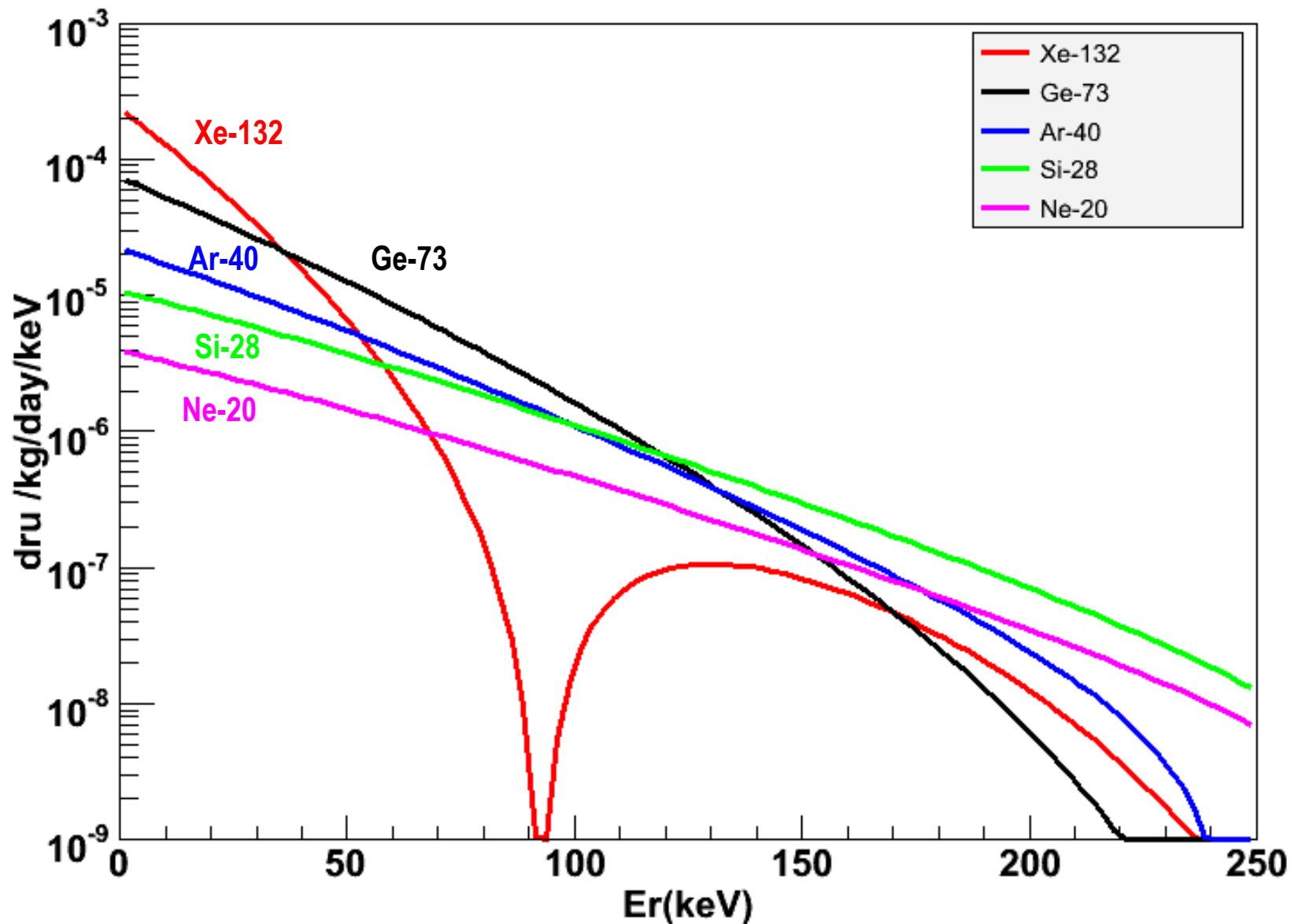

Detection Technique

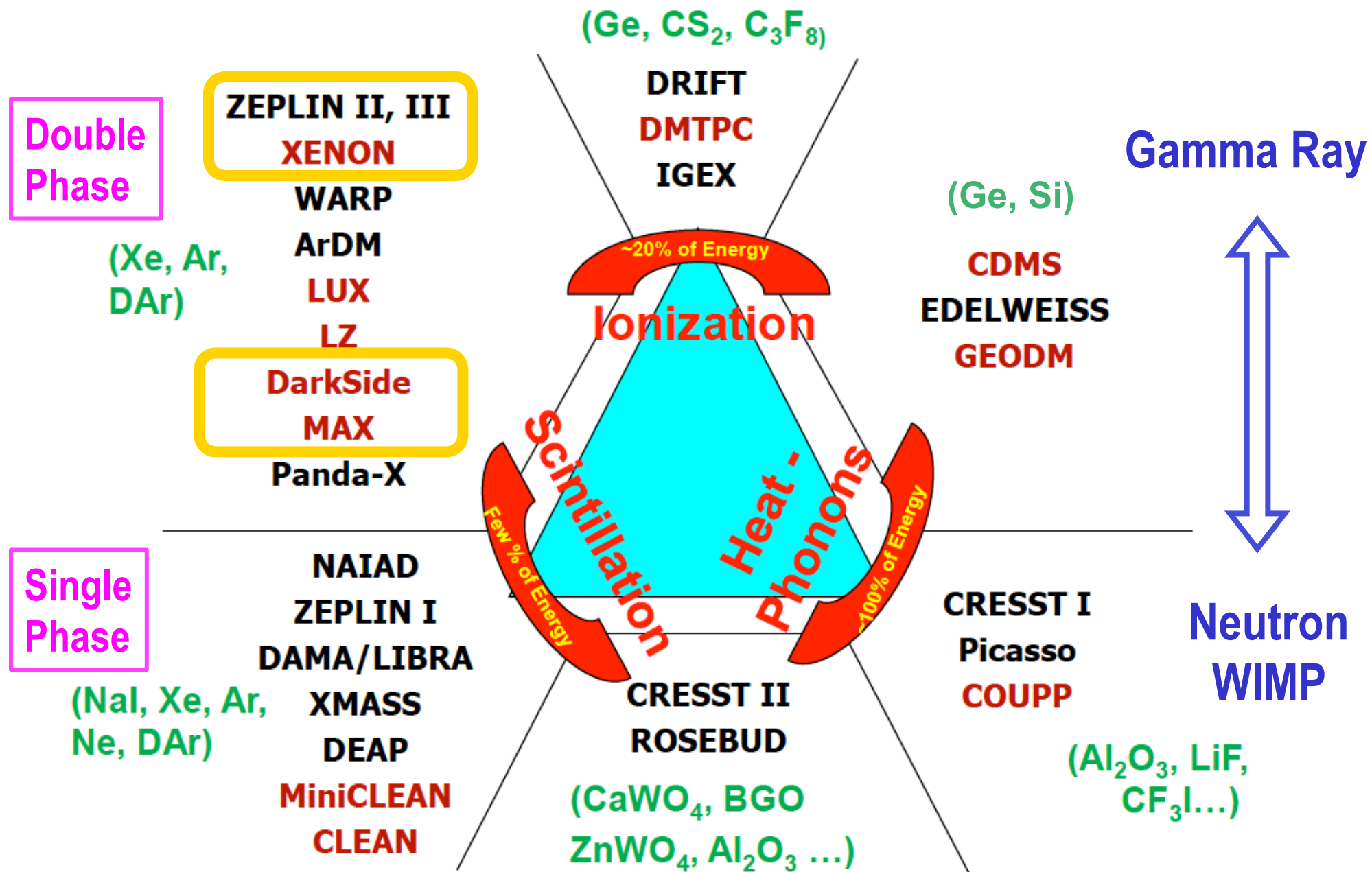

Double-Phase Noble Liquids

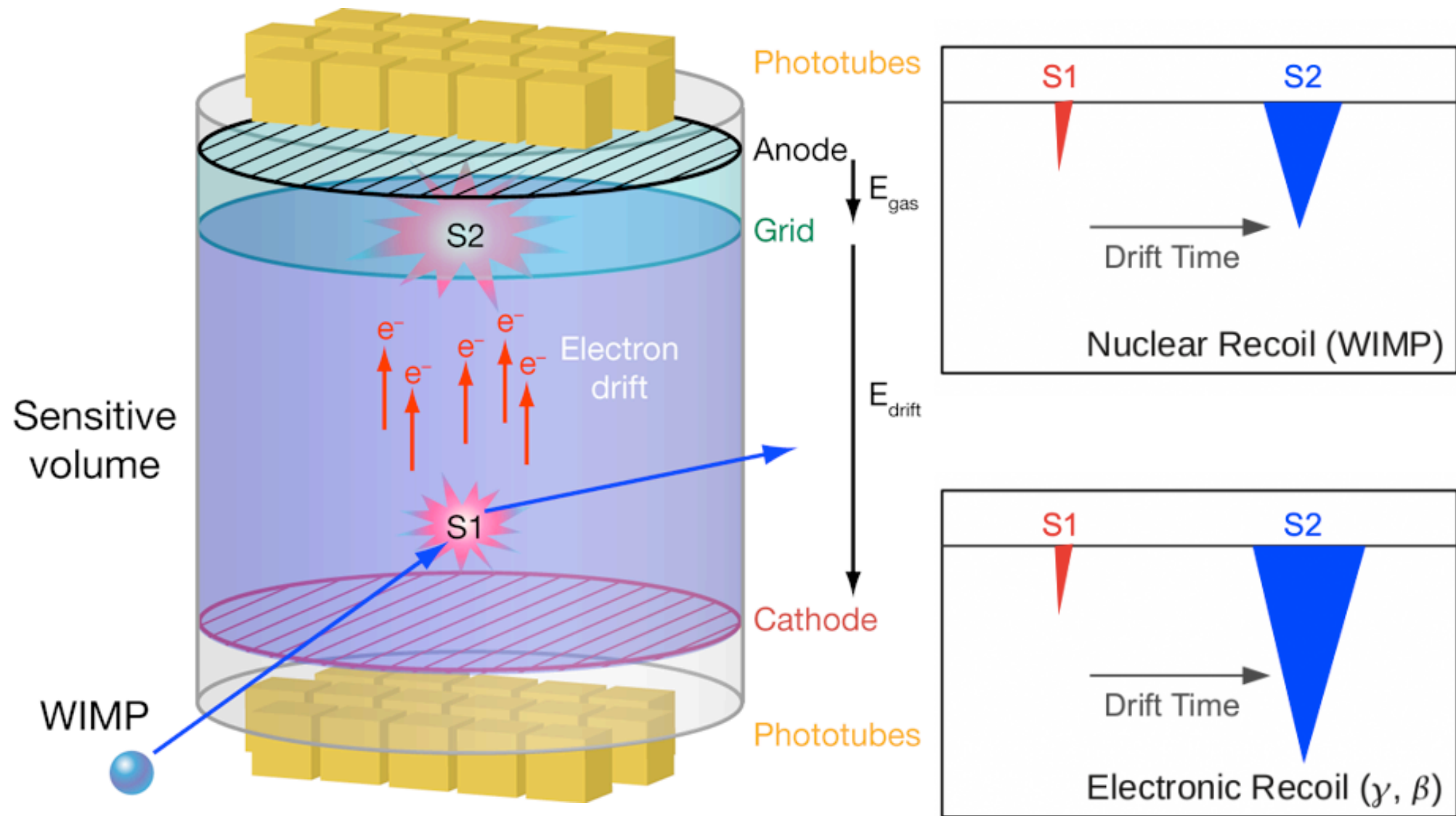

Principle of Double Phase TPC

10 keVnr

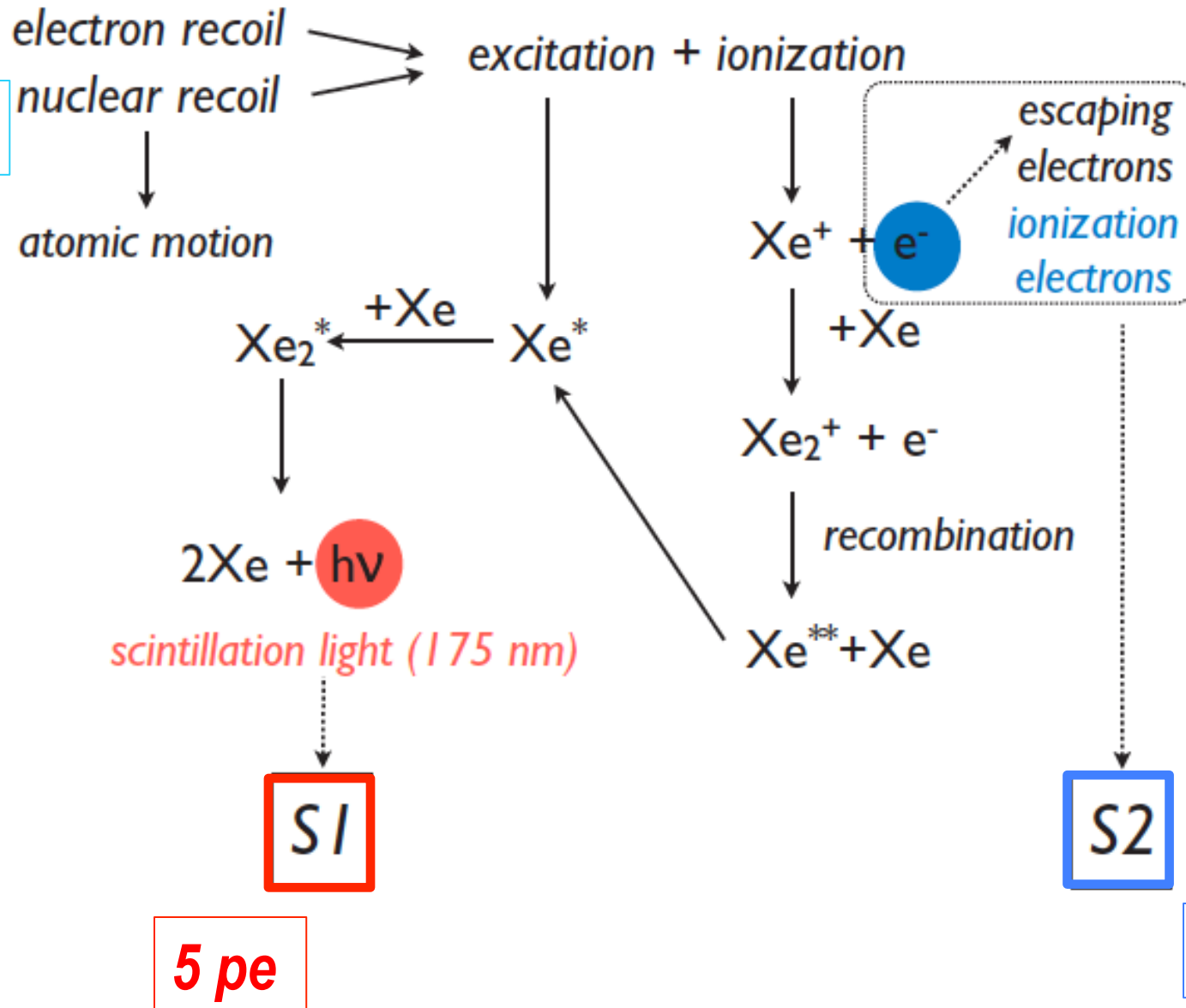

ZEPLIN II with Veto setup

Hanguo Wang & David Cline

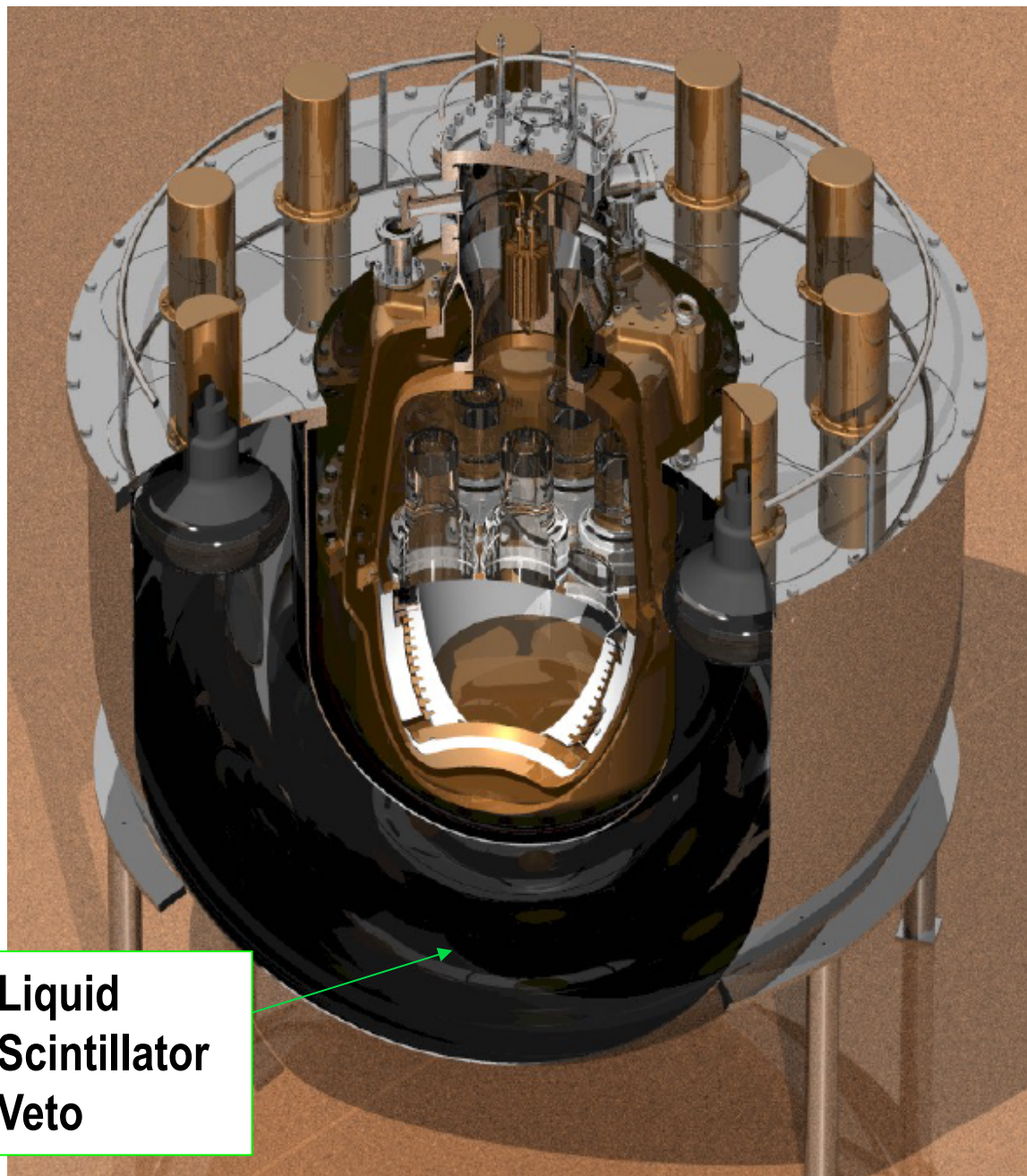

Liquid
Scintillator
Veto

Started R&D in early 1990's

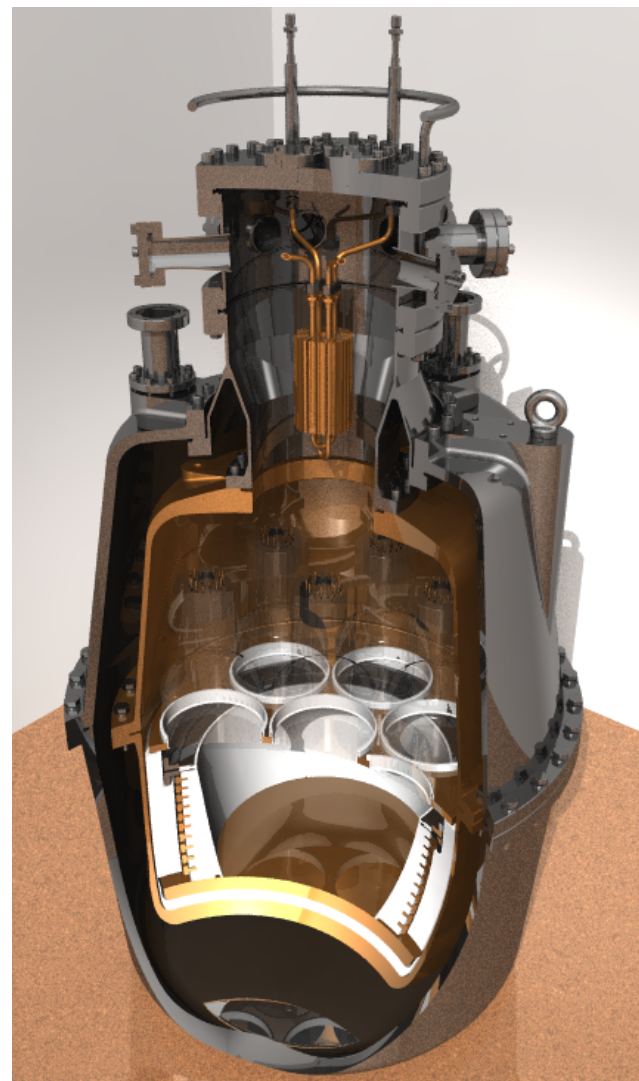

Internal details



Hanguo Wang closing the ZEPLIN II detector (2004?)

XENON Collaboration at Gran Sasso

UCLA joined in 2008



Columbia



Rice



UCLA



U Zürich



Coimbra



LNGS



Mainz



SJTU



Bologna



MPIK



NIKHEF



Purdue



Subatech



Münster



WIS

XENON100 Detector

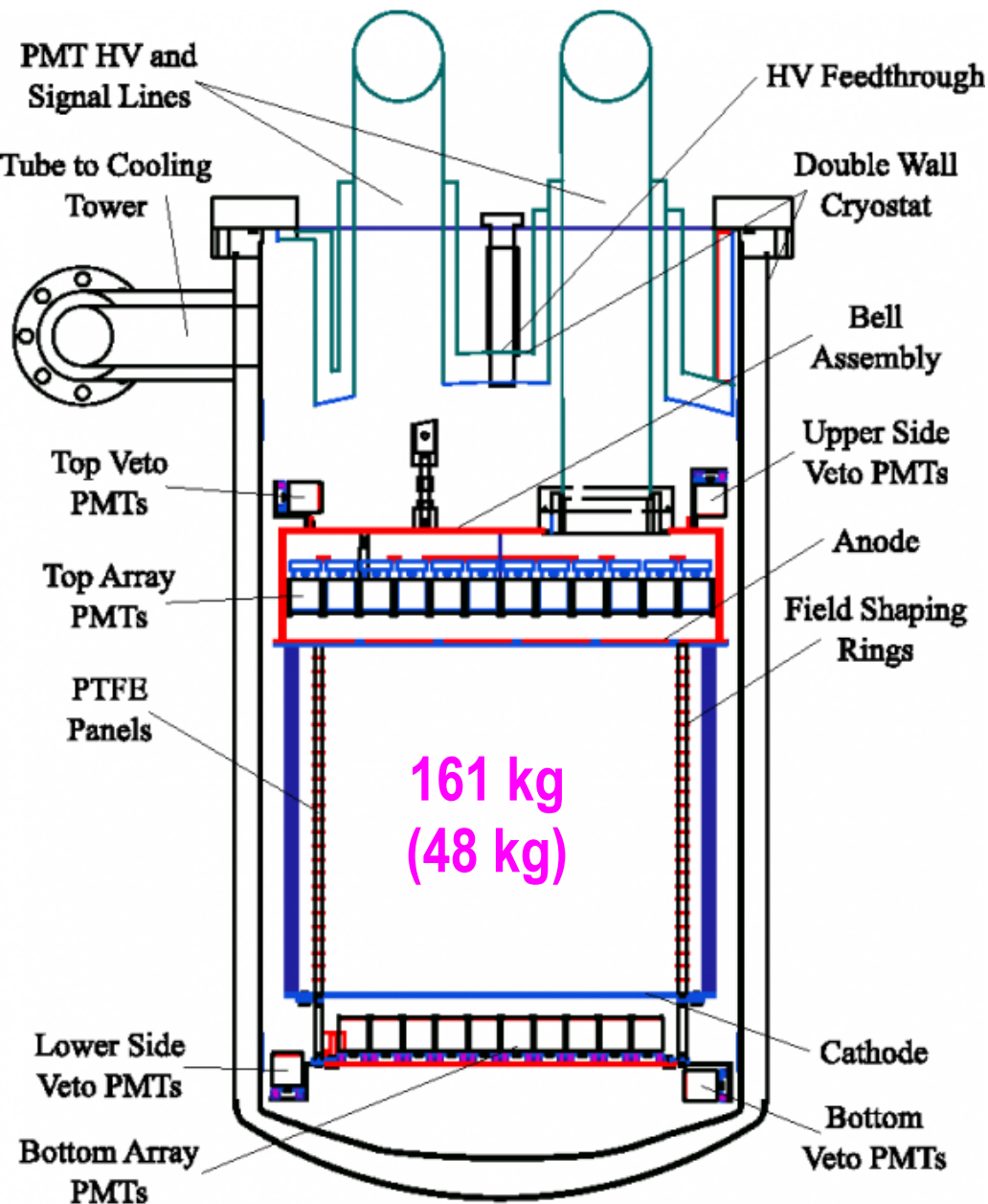

XENON100 Detector

Ethan Brown



Pb
(20cm)

Poly
(20cm)

Cu
(5cm)

Cu
(5cm)

Poly
(20cm)

Pb
(20cm)

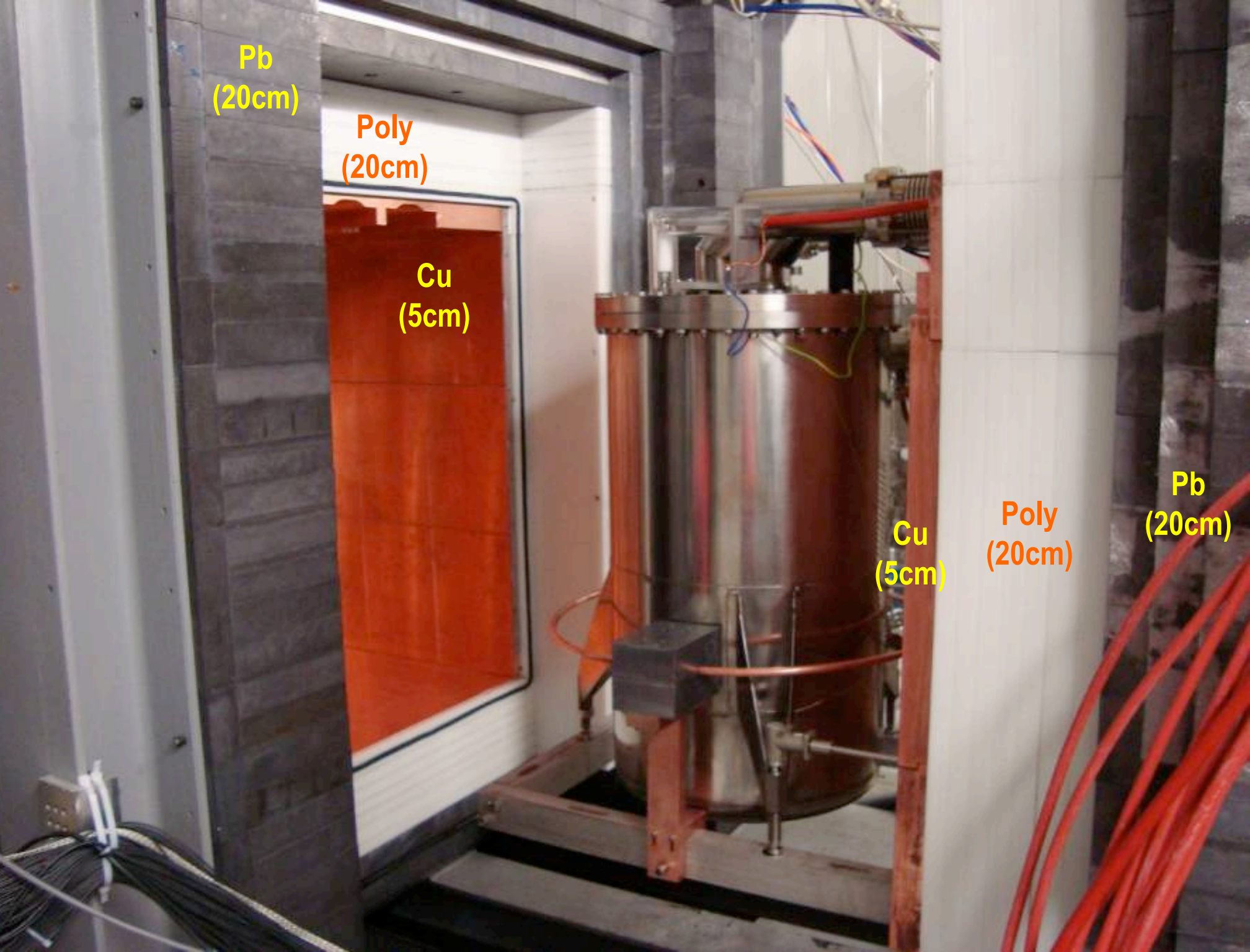

Gamma Backgrounds

Kevin Lung

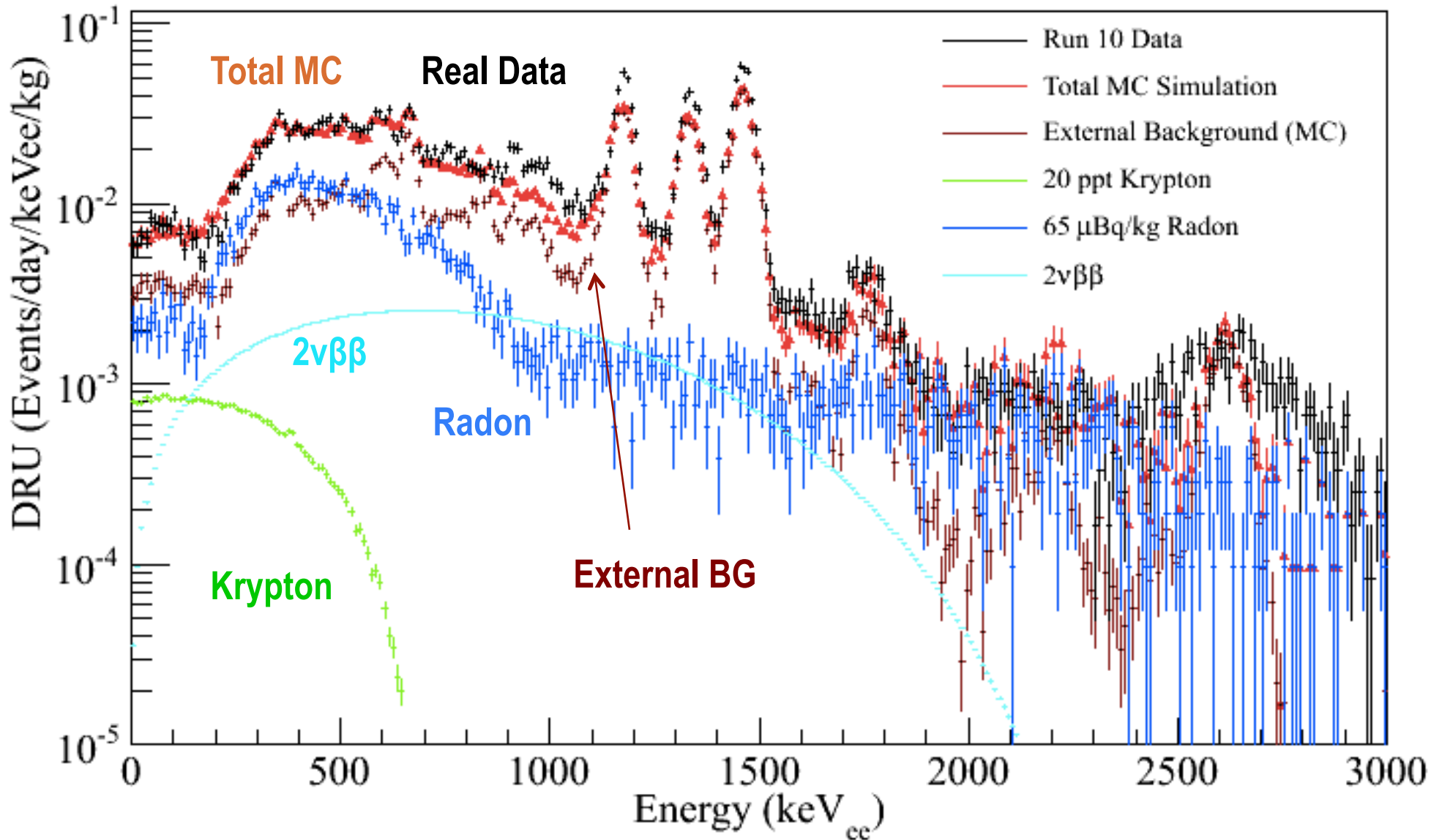

Gamma Backgrounds

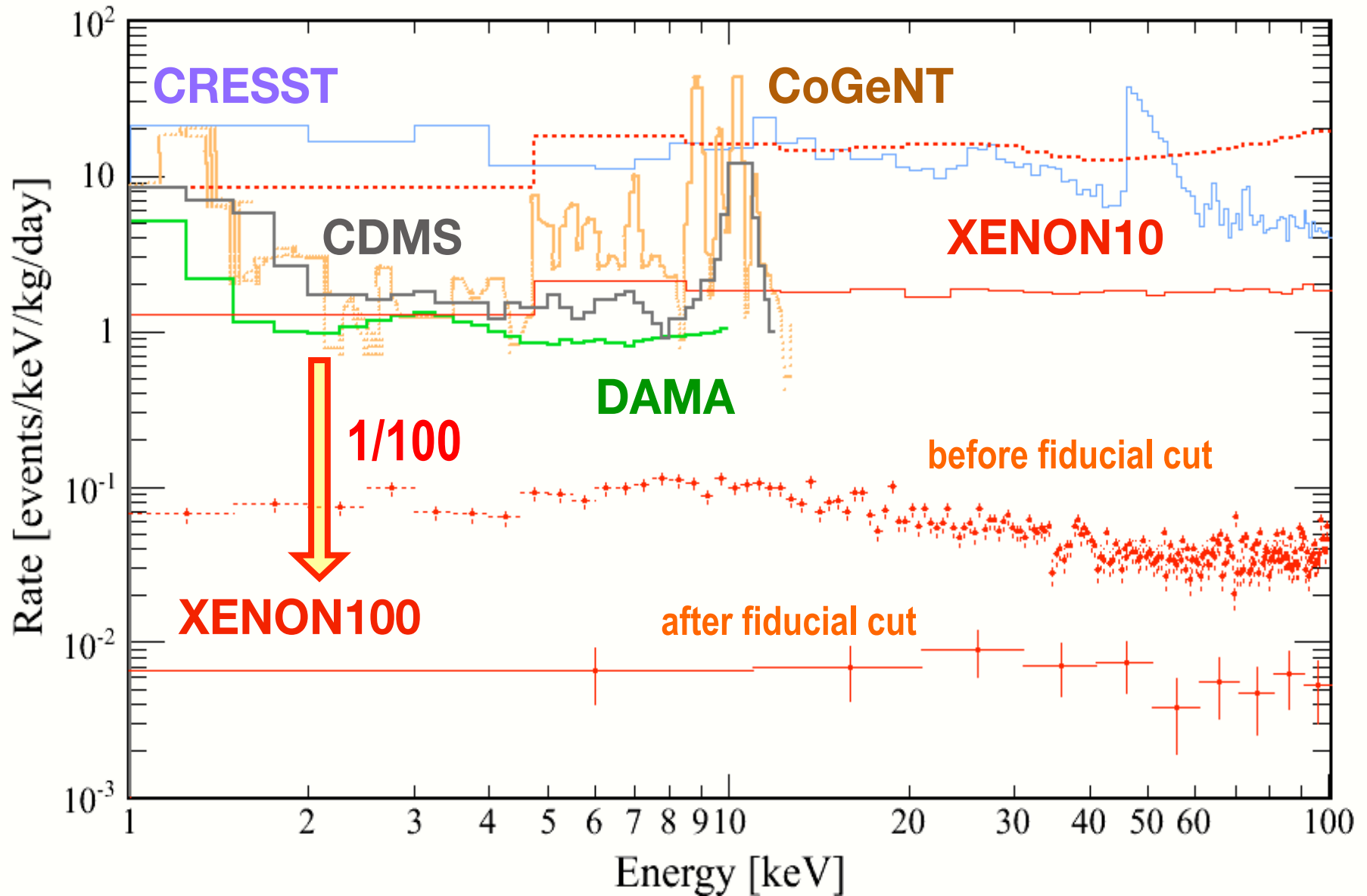

^{60}Co and AmBe Calibration Data

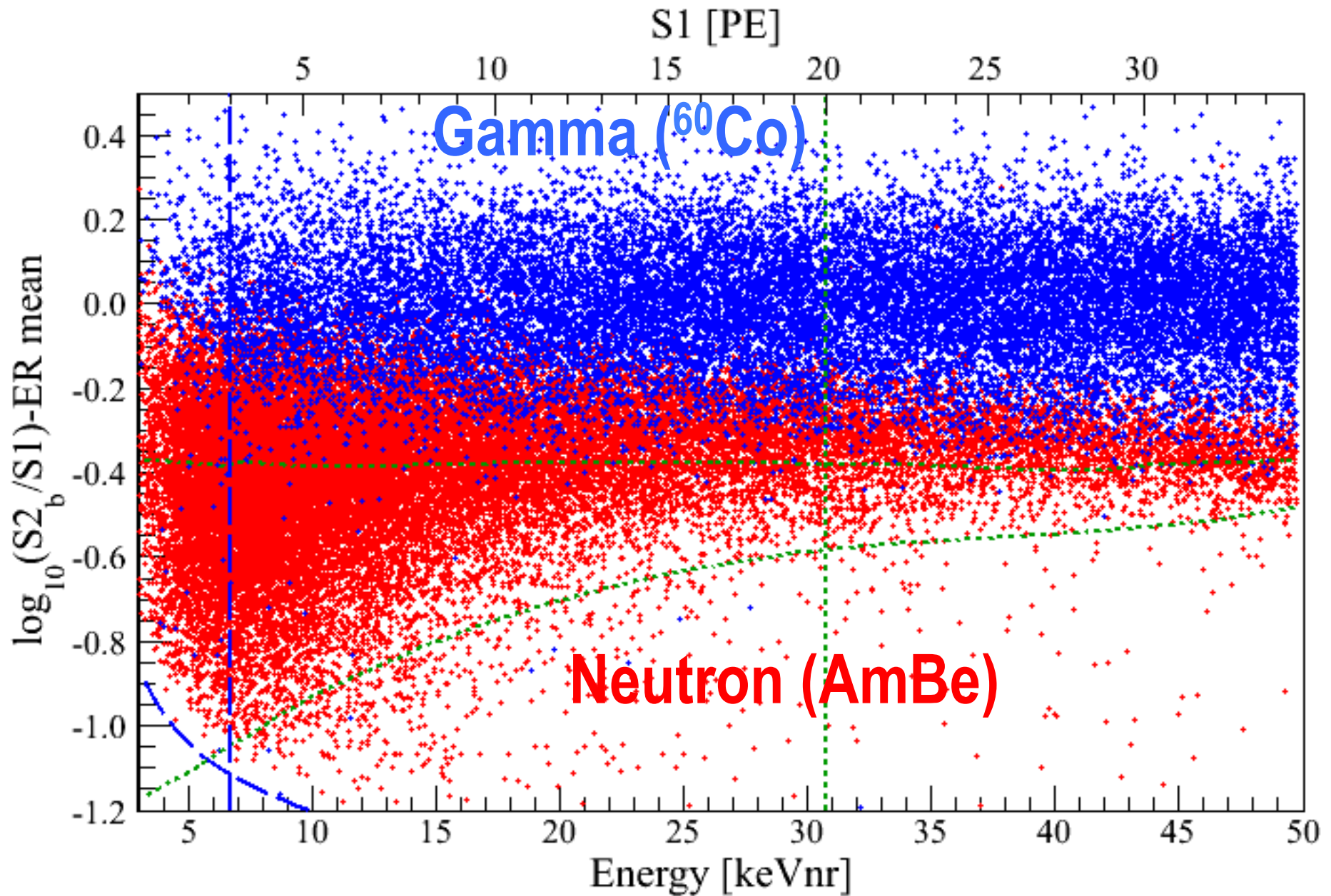

XENON0100 New Results

225 days, 34 kg

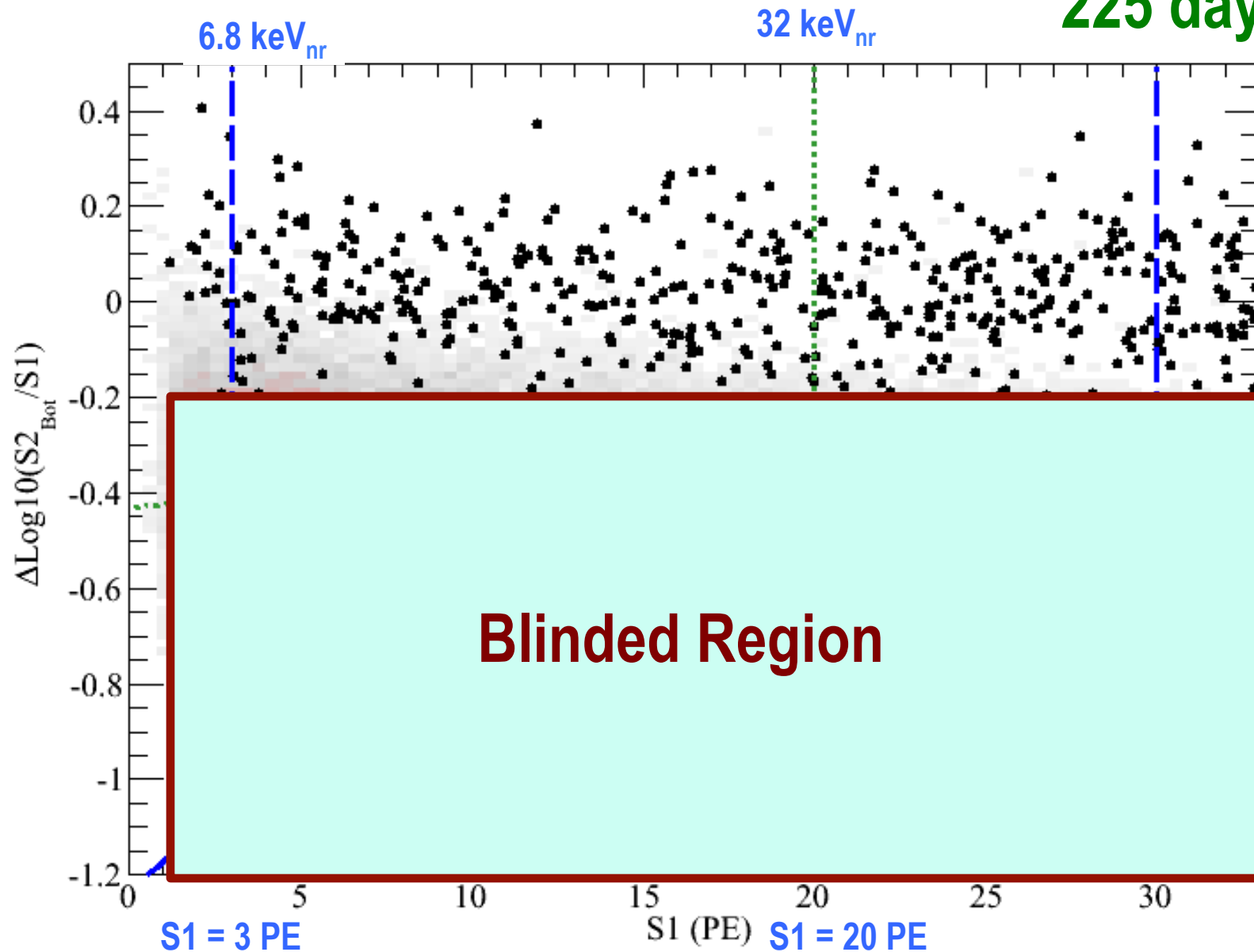

Unblinding on July 8

Before →

After ↘



XENON0100 New Results

225 days, 34 kg

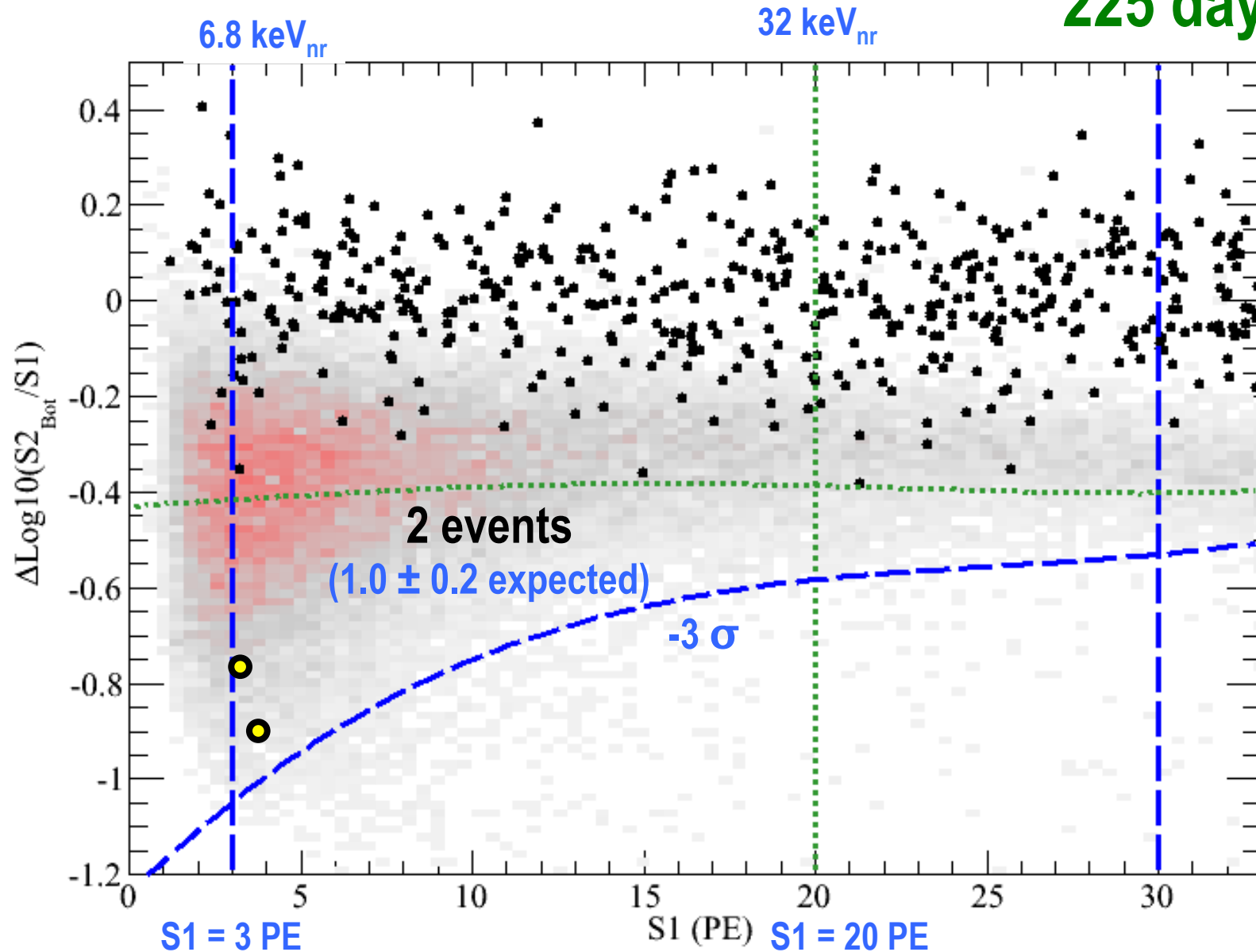

Unblinding results

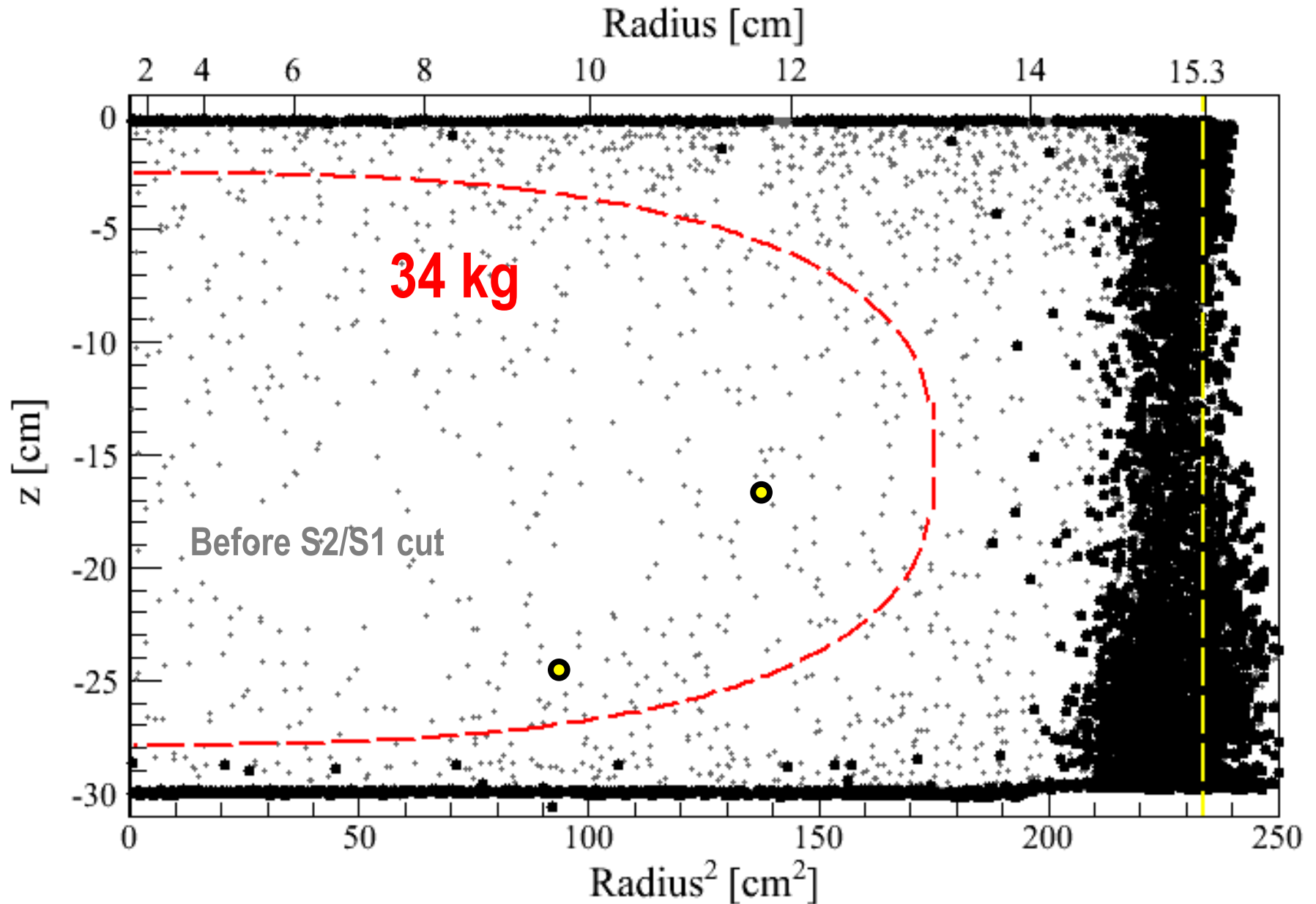

90% CL Limits of SI Cross Section (July, 2012)

Graciela Gelmini

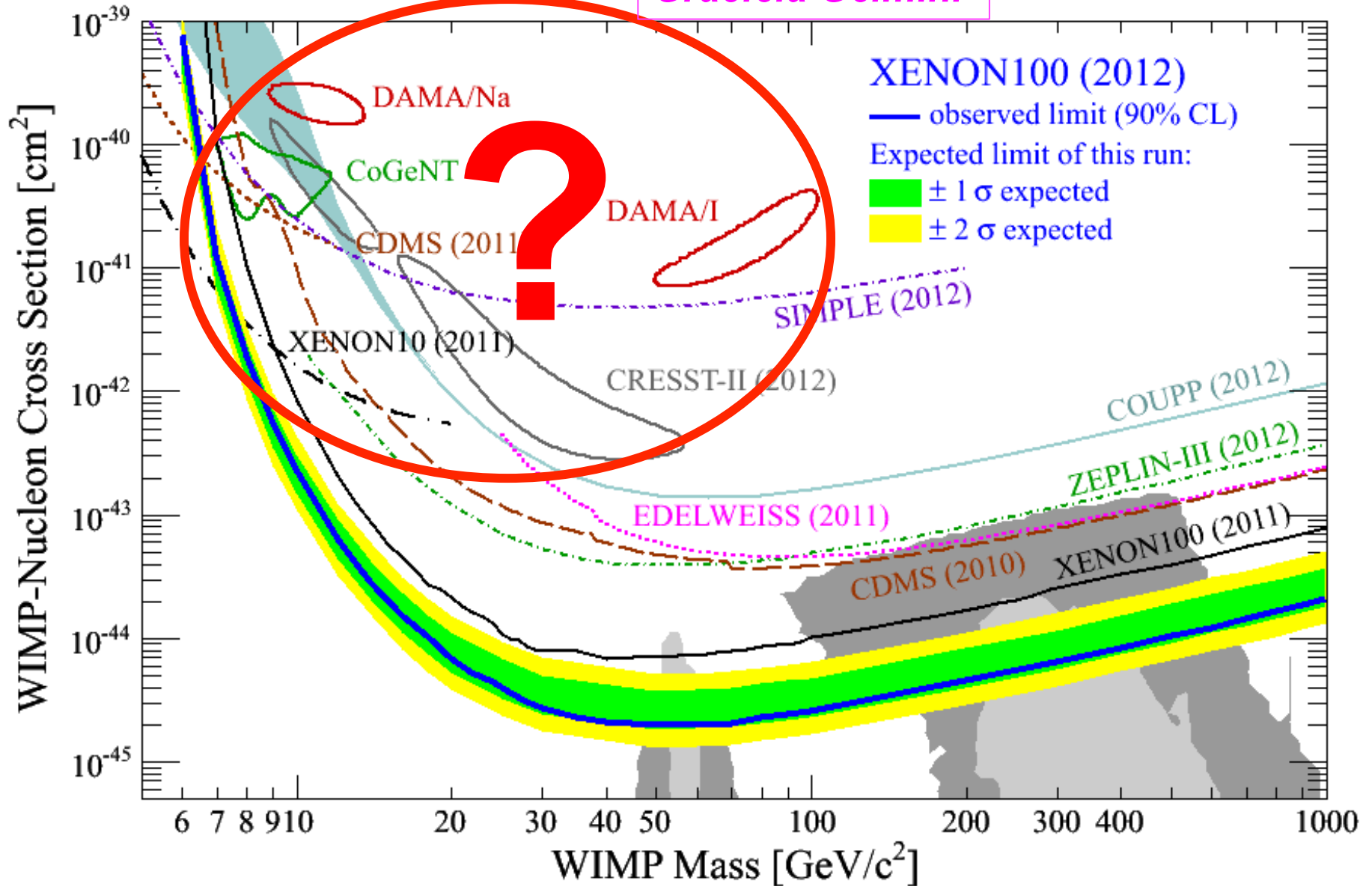

L_{eff} vs. Energy

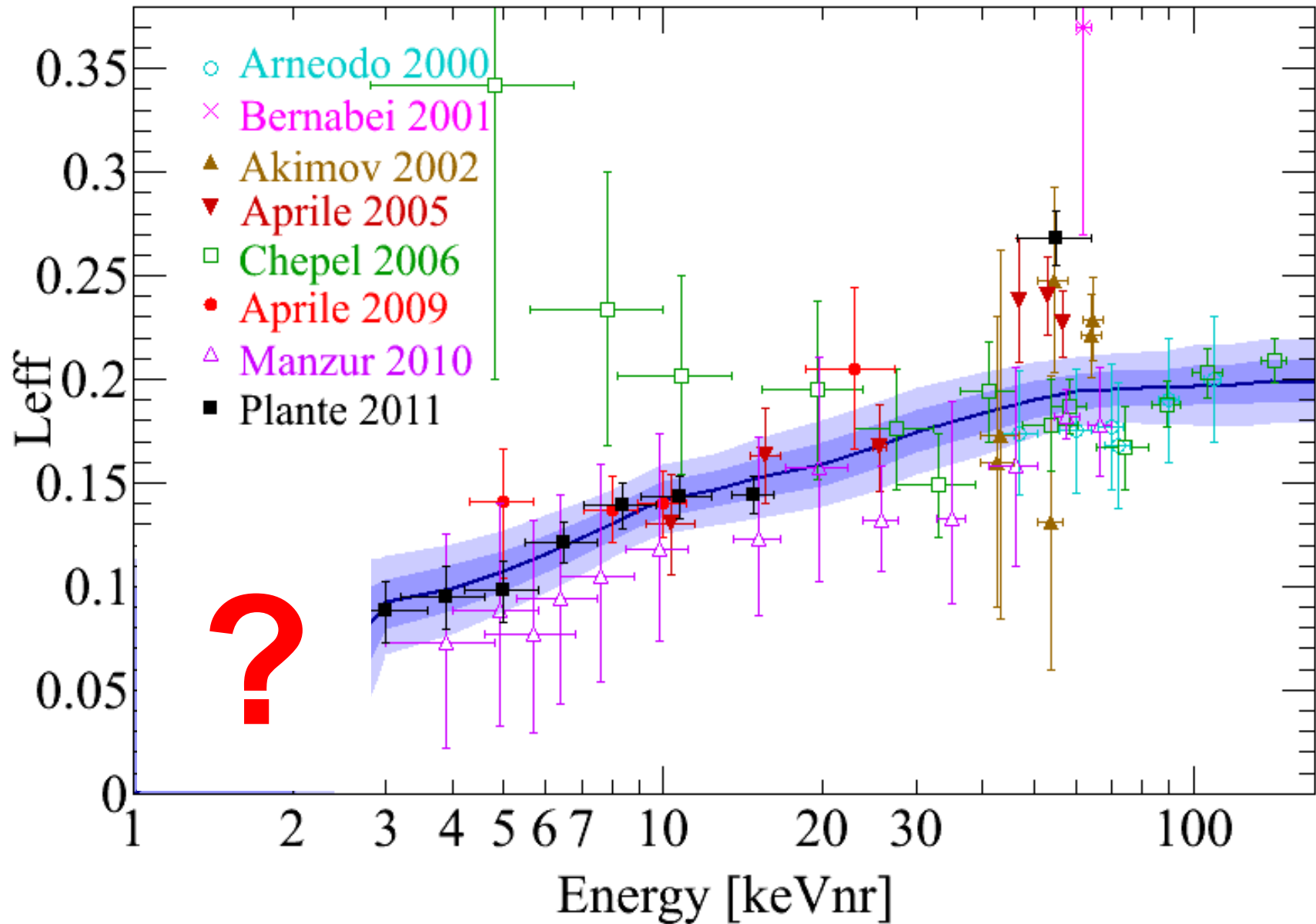

Sheldon is wondering $L_{\text{eff}} \dots$

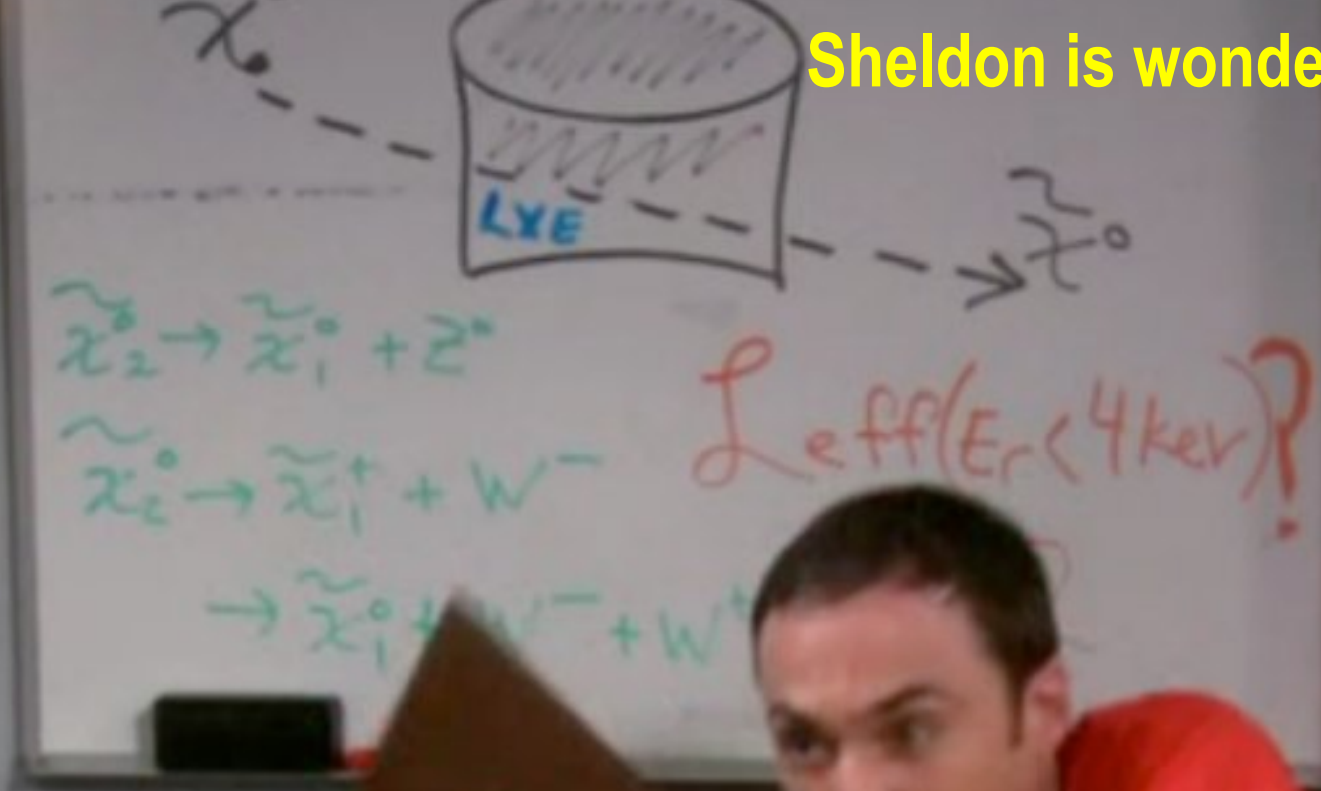

Principle of Double Phase TPC

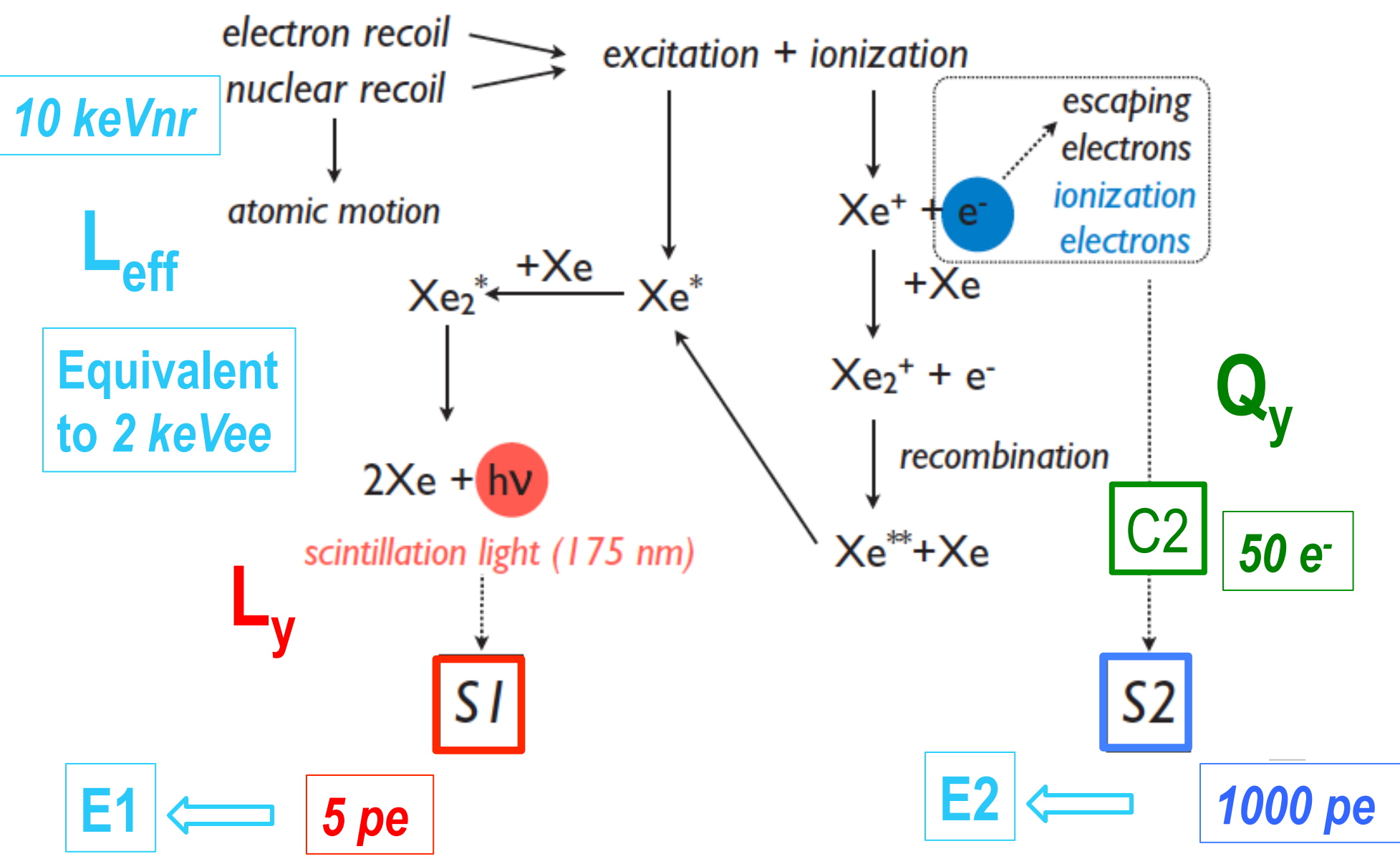

SI Cross Section vs. Mass

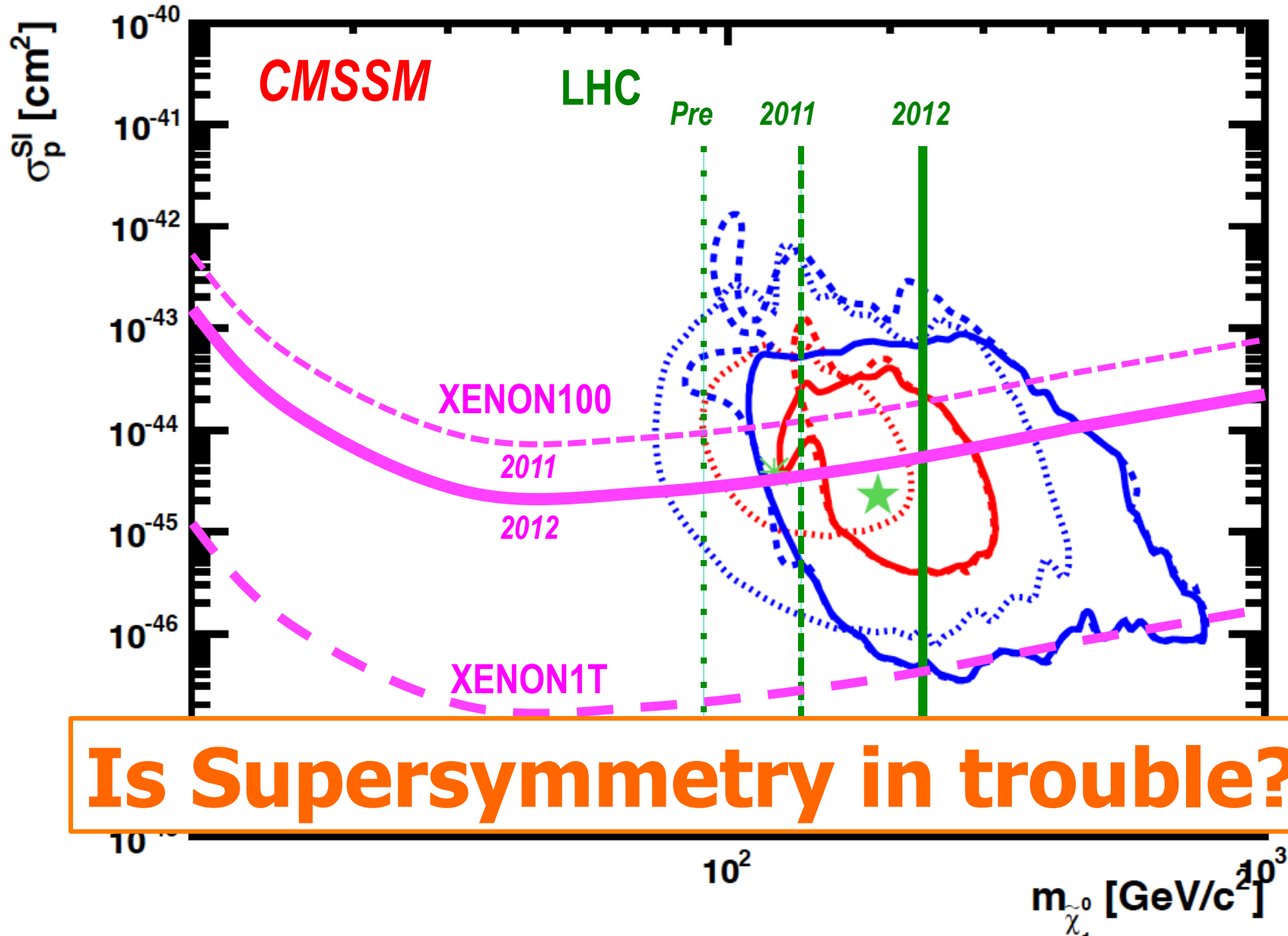

Is Supersymmetry in trouble?

Buchmueller et al [arXiv:1106.2529](https://arxiv.org/abs/1106.2529)

KK particles in Extra Dimensions

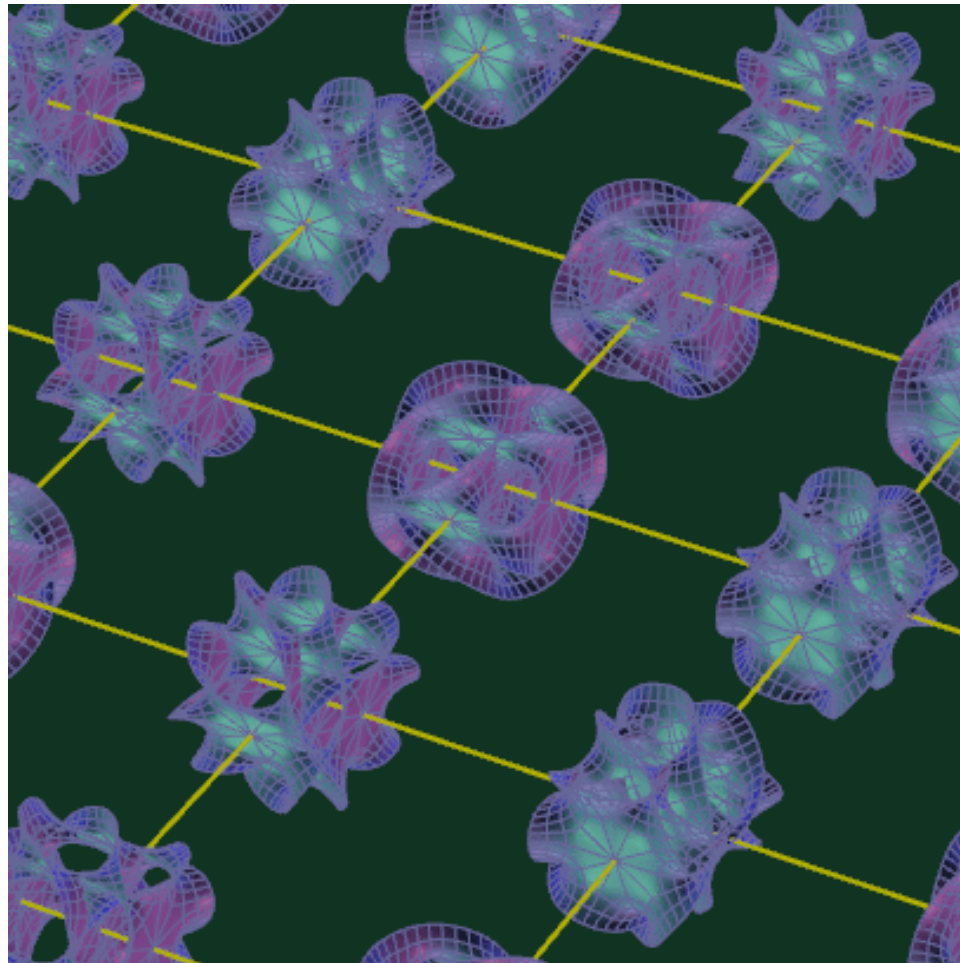

Origin of the Proton Mass

A real proton looks like this...

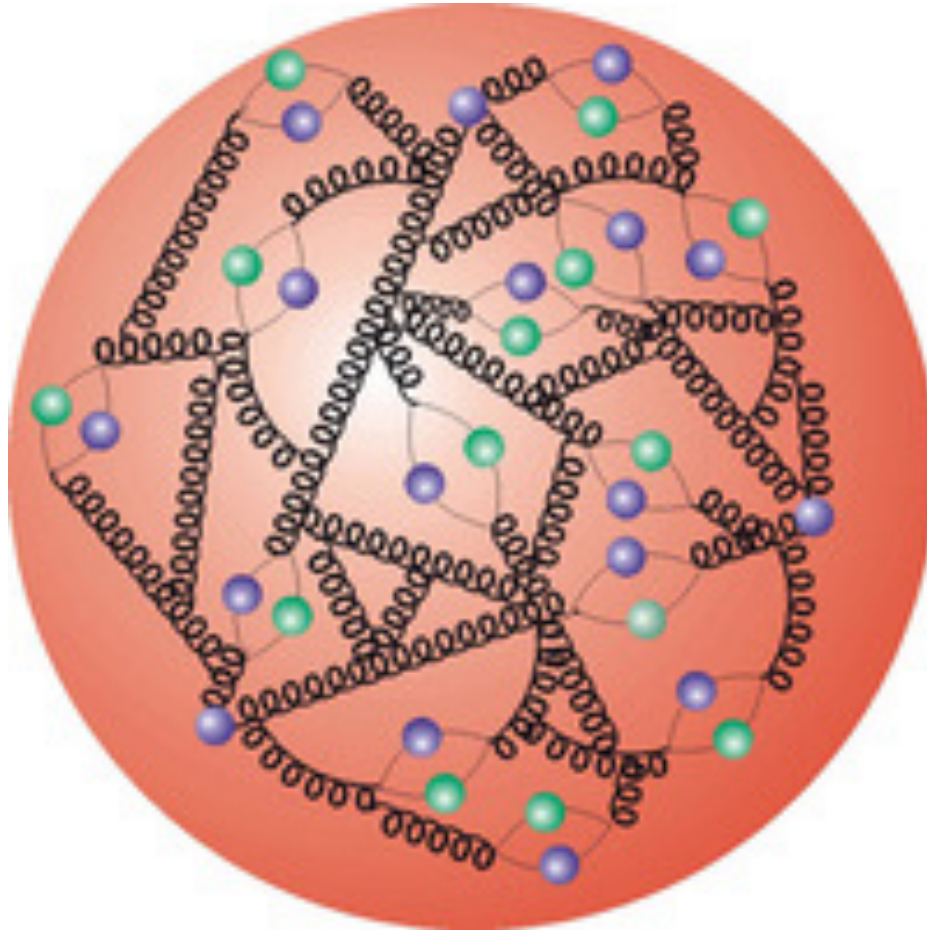

> 90% of its mass is due to kinetic energy of quarks and gluons.

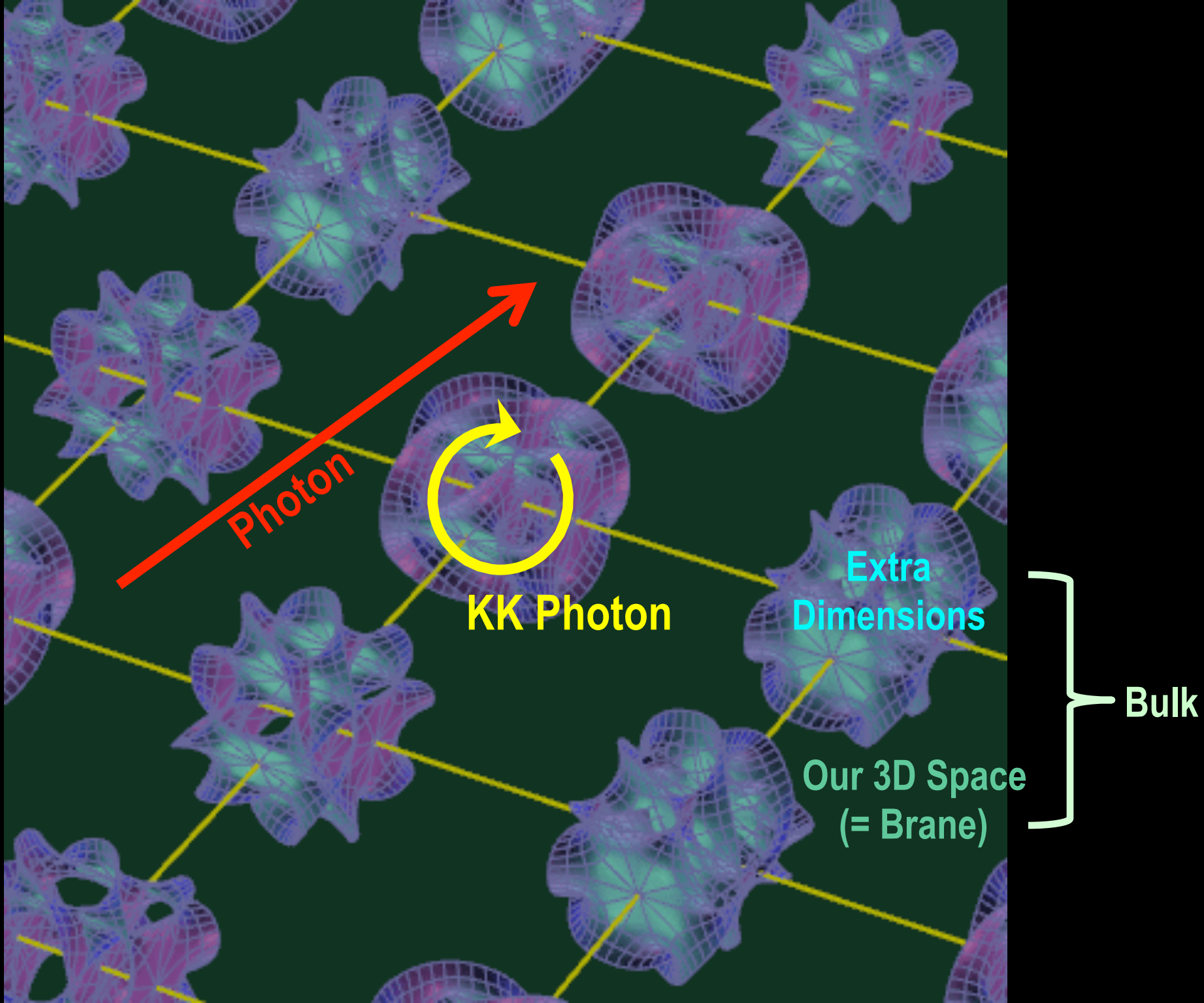

Origin of Mass in Extra Dimensions

$$E = mc^2 \rightarrow m = E/c^2$$

- Mass can be generated as kinetic energy in extra dimensions.
 - Origin on mass
 - Dark matter is running in the extra dimensions
- Gravity can escape into the extra dimensions.
 - Why gravity is so small
 - Origin of dark energy

Mass Spectrum of the first KK level

Similar to the SUSY mass spectrum

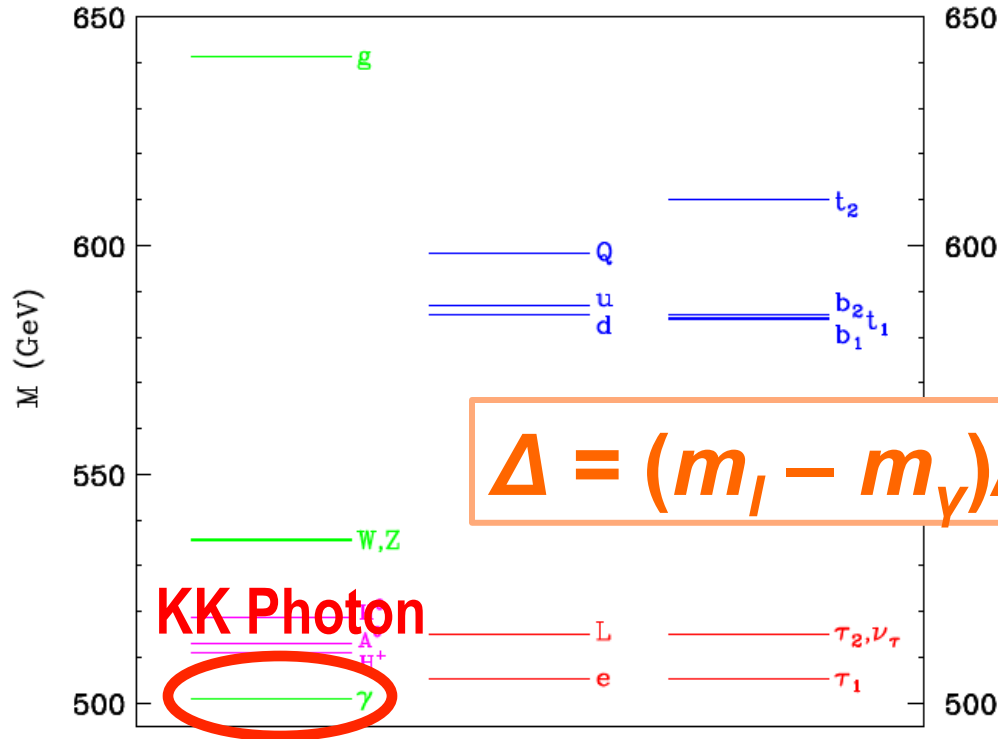

FIG. 1: One-loop corrected mass spectrum of the first KK level in MUEDs for $R^{-1} = 500$ GeV, $\Lambda R = 20$ and $m_h = 120$ GeV.

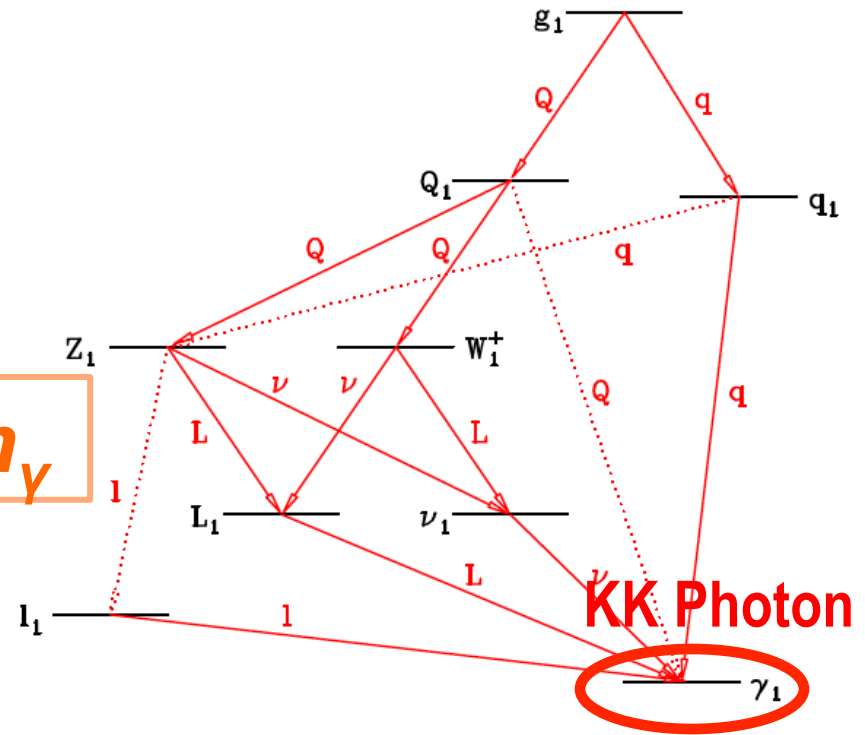
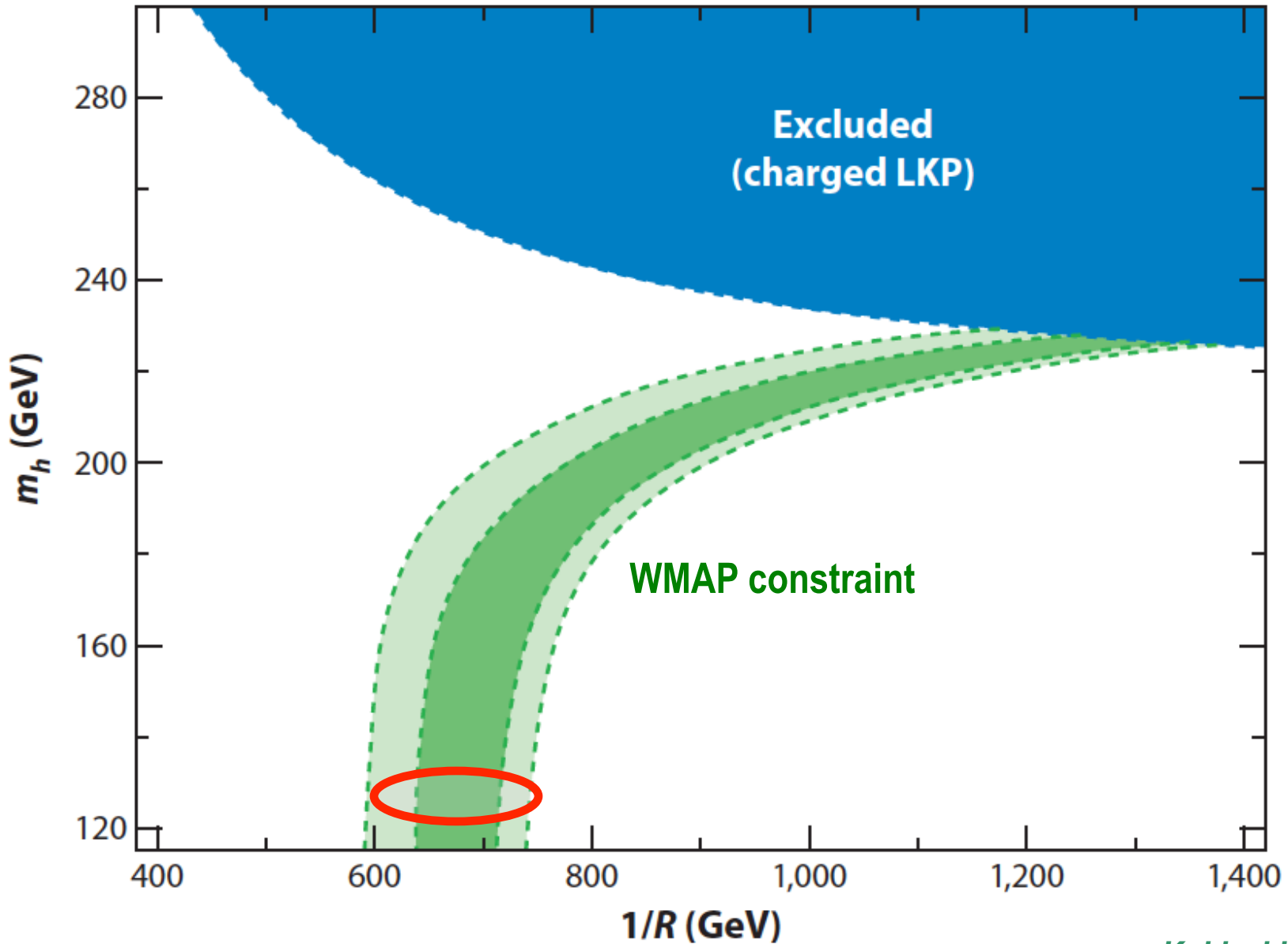

FIG. 3: Qualitative sketch of the level 1 KK spectroscopy depicting the dominant (solid) and rare (dotted) transitions and the resulting decay product.

Cheng 2002 [arXiv:hep-ph/0205314v1](https://arxiv.org/abs/hep-ph/0205314v1)

Allowed Region of Minimum Universal Extra Dimensions



Kakizaki 2006

Predicted Cross Section of Kaluza-Klein Dark Matter

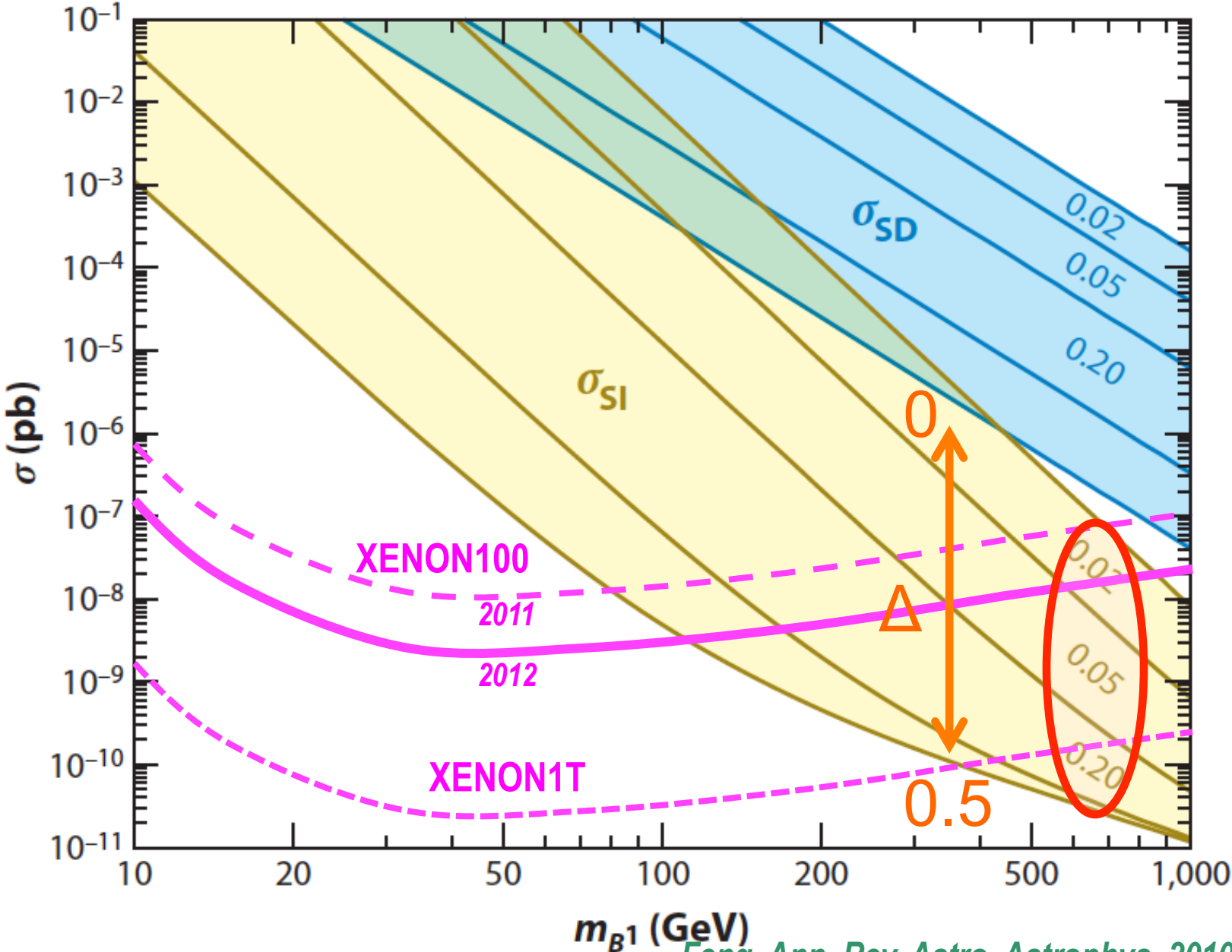

Feng *Ann. Rev. Astro. Astrophys.* 2010.48:495-545

Sensitivity to KK particles

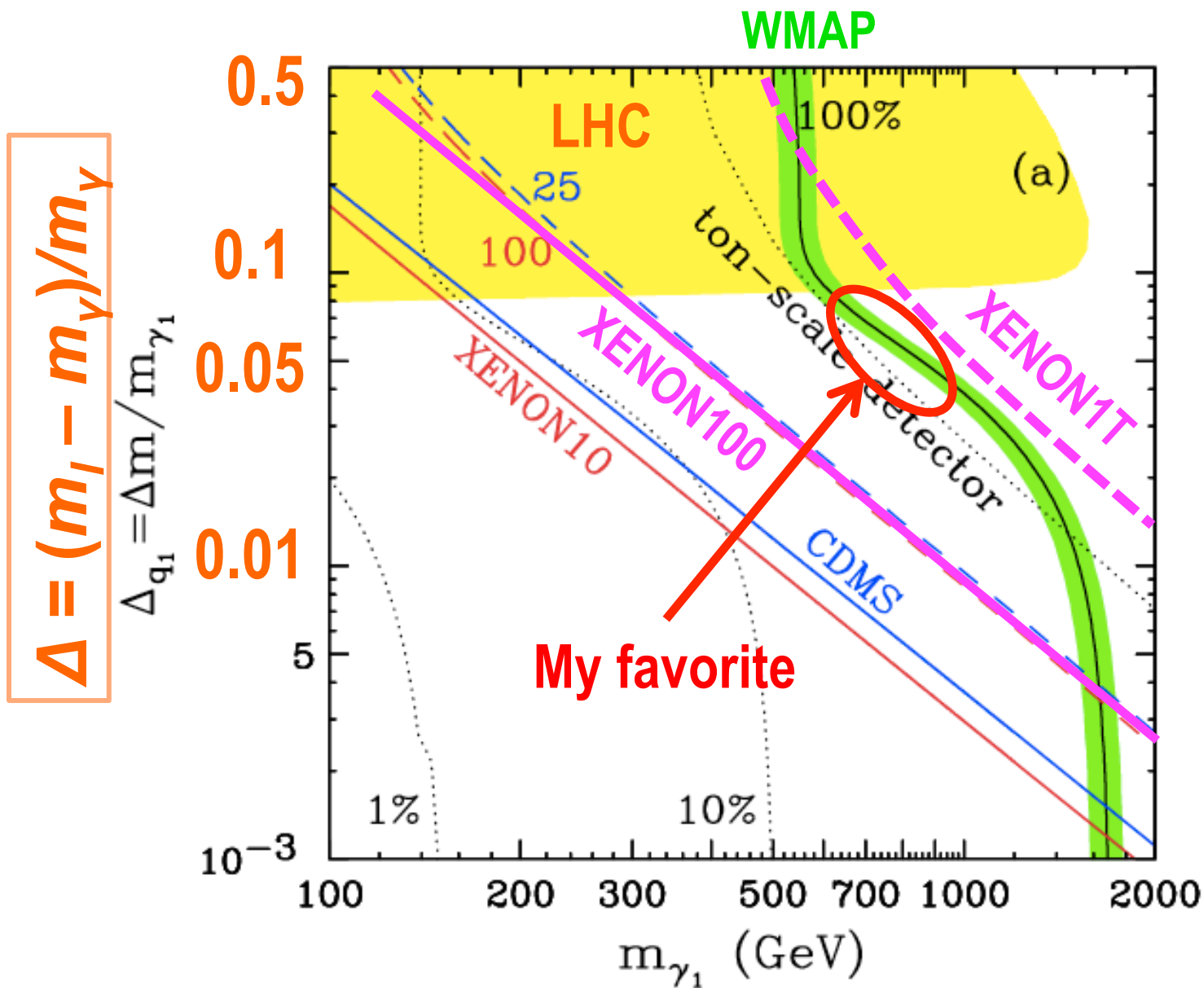

Arrenberg 2008

What is Dark Matter?

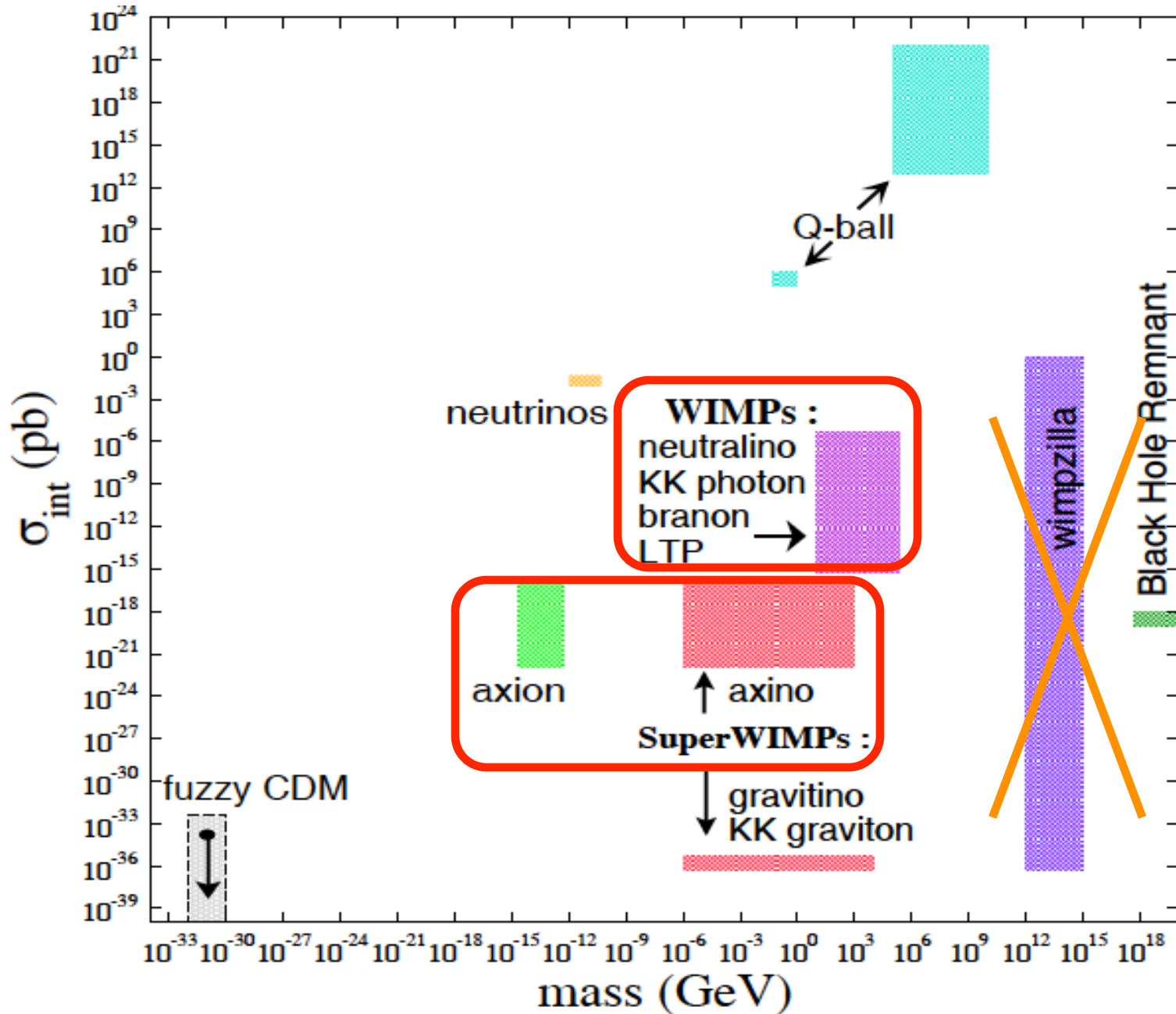

Properties of Axion

- The Axion is a light pseudoscalar resulting from the **Peccei-Quinn mechanism** to enforce strong-CP conservation
- f_a , the SSB scale of PQ-symmetry, is the one important parameter in the theory

Mass and Couplings

$$m_a \sim 6 \mu\text{eV} \cdot \left(\frac{10^{12} \text{ GeV}}{f_a} \right)$$

Generically, all couplings

$$g_{a\text{ii}} \propto \frac{1}{f_a}$$

Cosmological Abundance

$$\Omega_a \sim \left(\frac{5 \mu\text{eV}}{m_a} \right)^{7/6}$$

(Vacuum misalignment mechanism)

Coupling to Photons

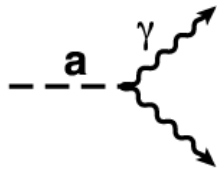

$$g_{a\gamma\gamma} = \frac{\alpha g_\gamma}{\pi f_a}; g_\gamma = \begin{cases} 0.97 \text{ KSVZ} \\ -0.36 \text{ DFSZ} \end{cases}$$

Axion Mass 'Window'

$$10^{-(5 \text{ to } 6)} \text{ eV} < m_a < 10^{-(2 \text{ to } 3)} \text{ eV}$$

(Overclosure) (SN1987a)

With lower end of window preferred if $\Omega_{\text{CDM}} \sim 1$

Primakoff Conversion

The principle of the RF cavity experiments

Energy exchange between
Galactic Halo Axions and E&M field

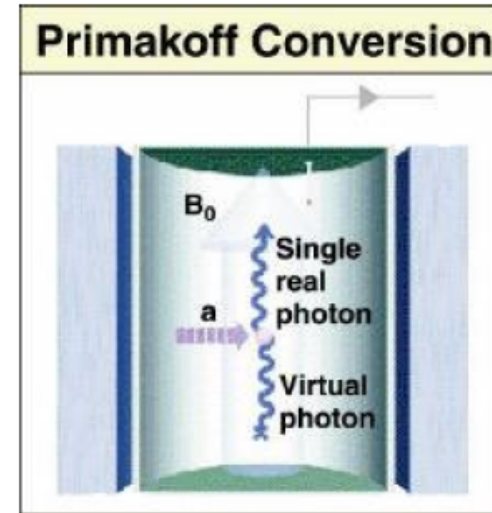
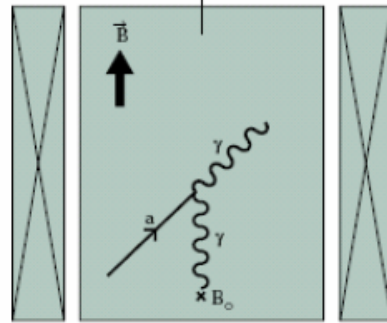

Galactic halo axions have speeds $\beta=10^{-3}$

The principle of Axion Helioscopes

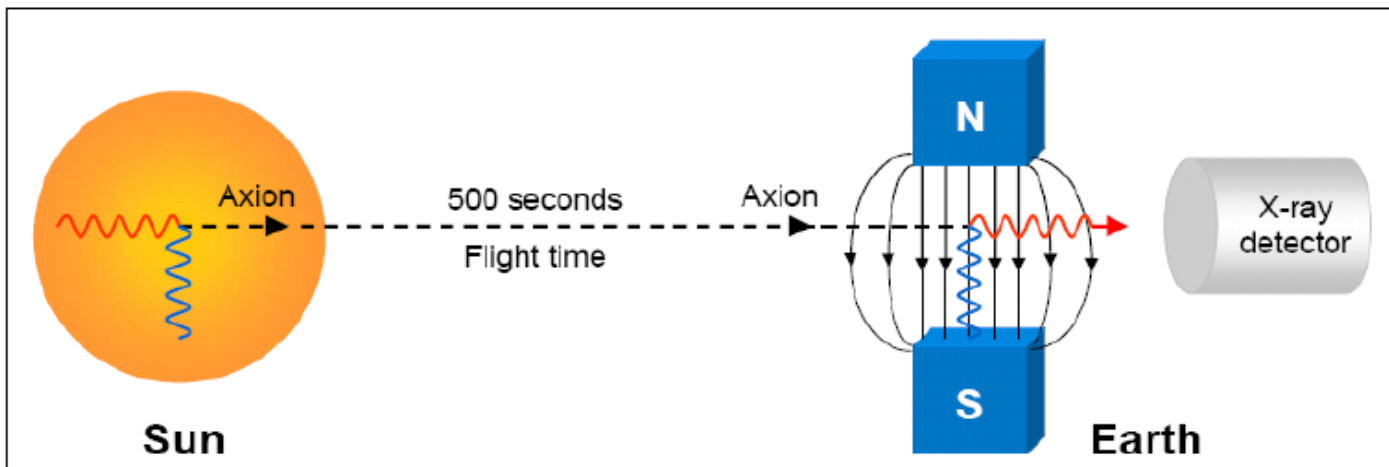

ADMX

ADMX: Axion Dark-Matter eXperiment Currently the largest RF-cavity search

*U. of Washington, LLNL, U. of Florida, U.C. Berkeley,
National Radio Astronomy Observatory,
U. of Virginia, Sheffield U., Yale U.*

Magnet with insert

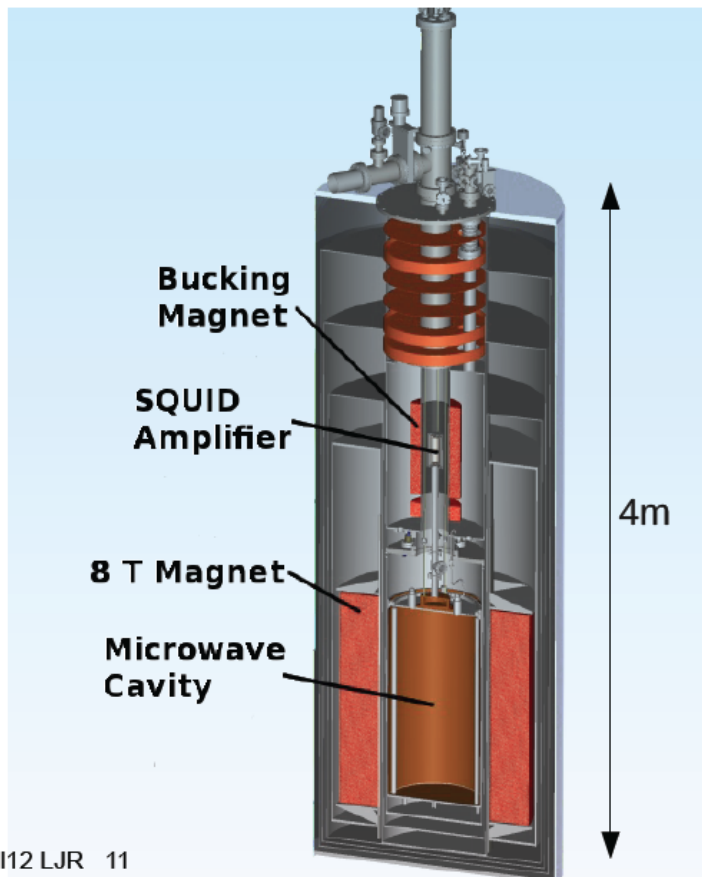

IDM23jul12 LJR 11

Magnet cryostat



CAST at CERN

- Decommissioned LHC test magnet (L=10 m, B=9 T)
- Moving platform $\pm 8^\circ V$, $\pm 40^\circ H$ (allows 3 hours/day of solar tracking)
- 4 magnet bores to look for x-rays from axion conversion
- X-ray focusing system to increase signal/background ratio

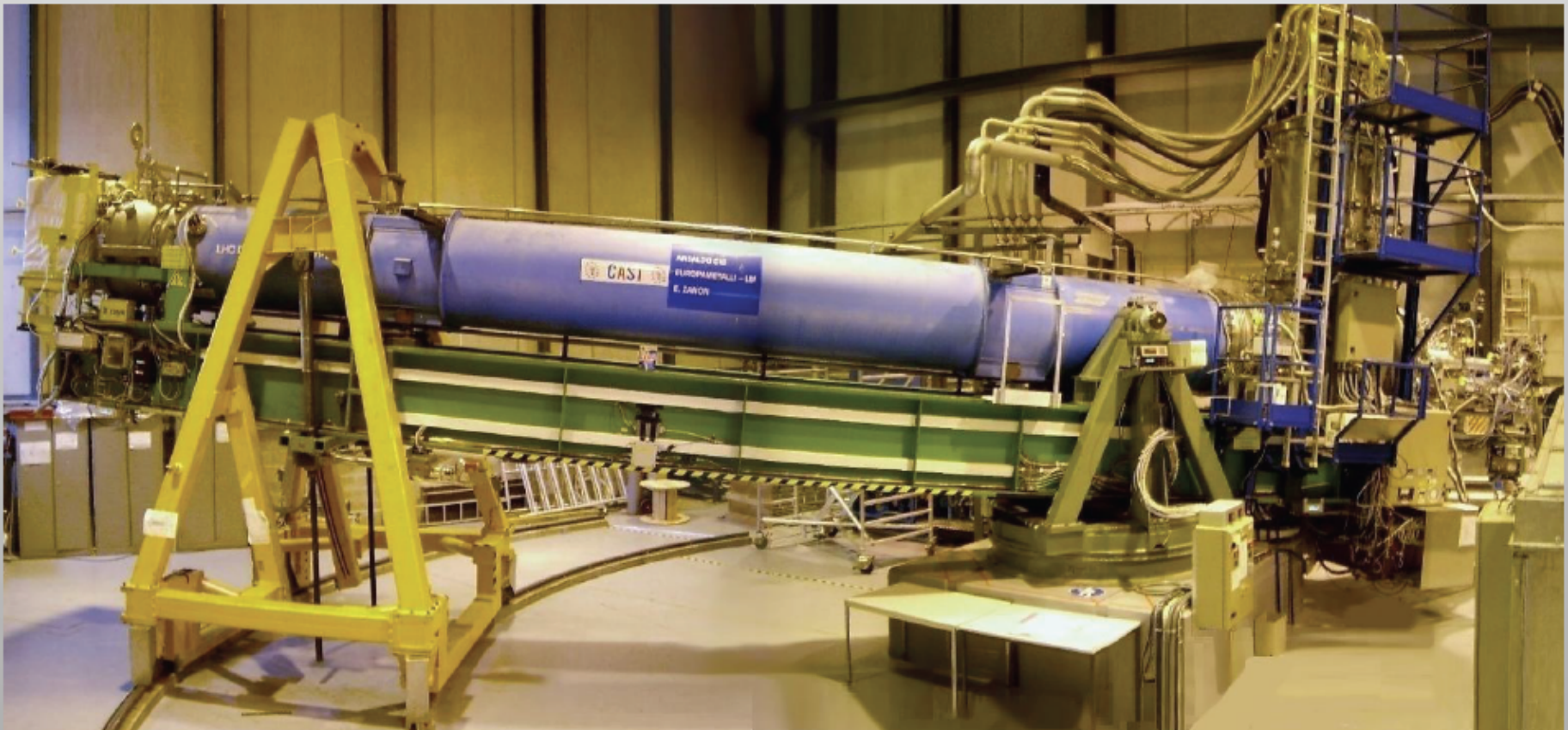

Status of Axion Search

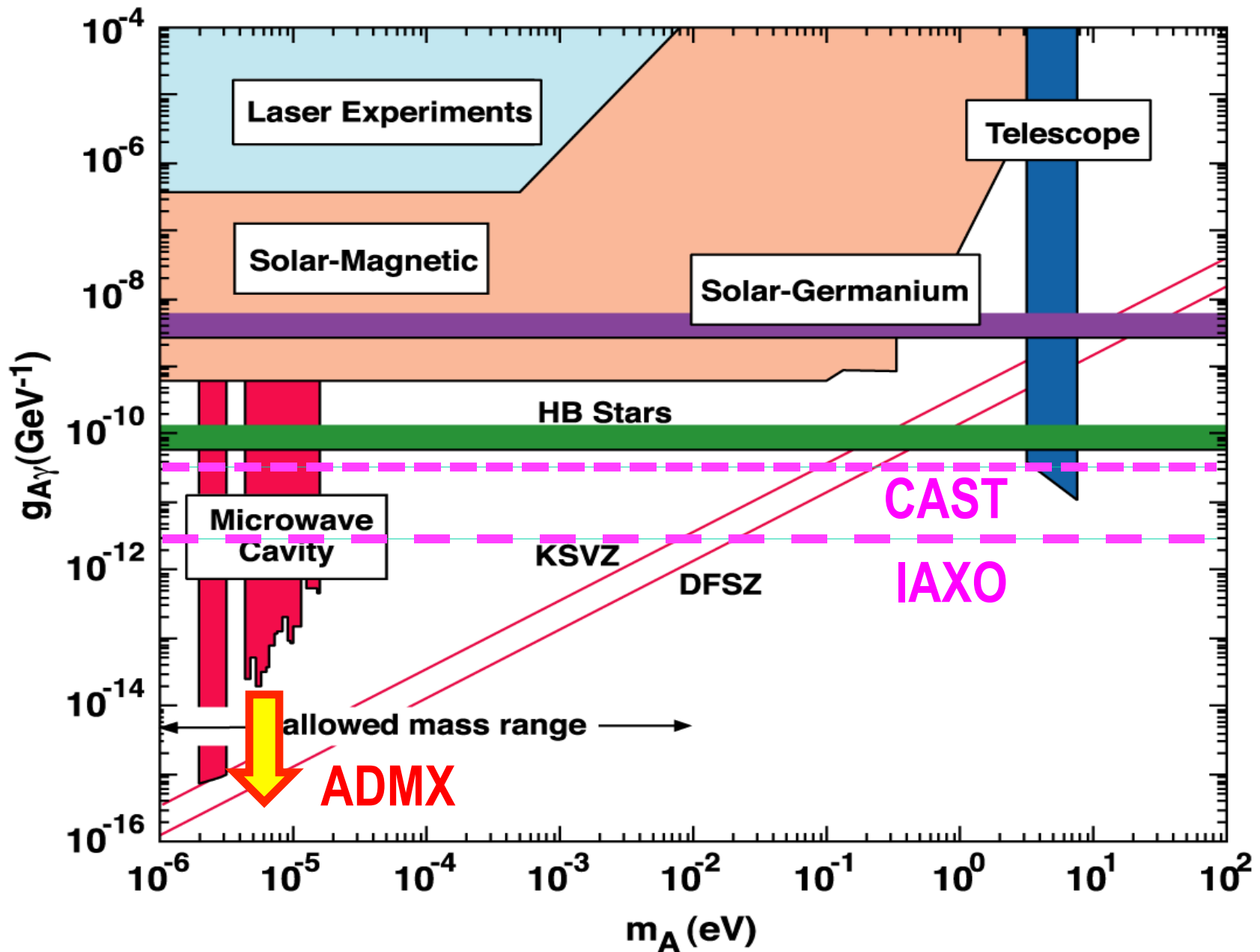

Axion search by XENON using Axio-Electric Effect

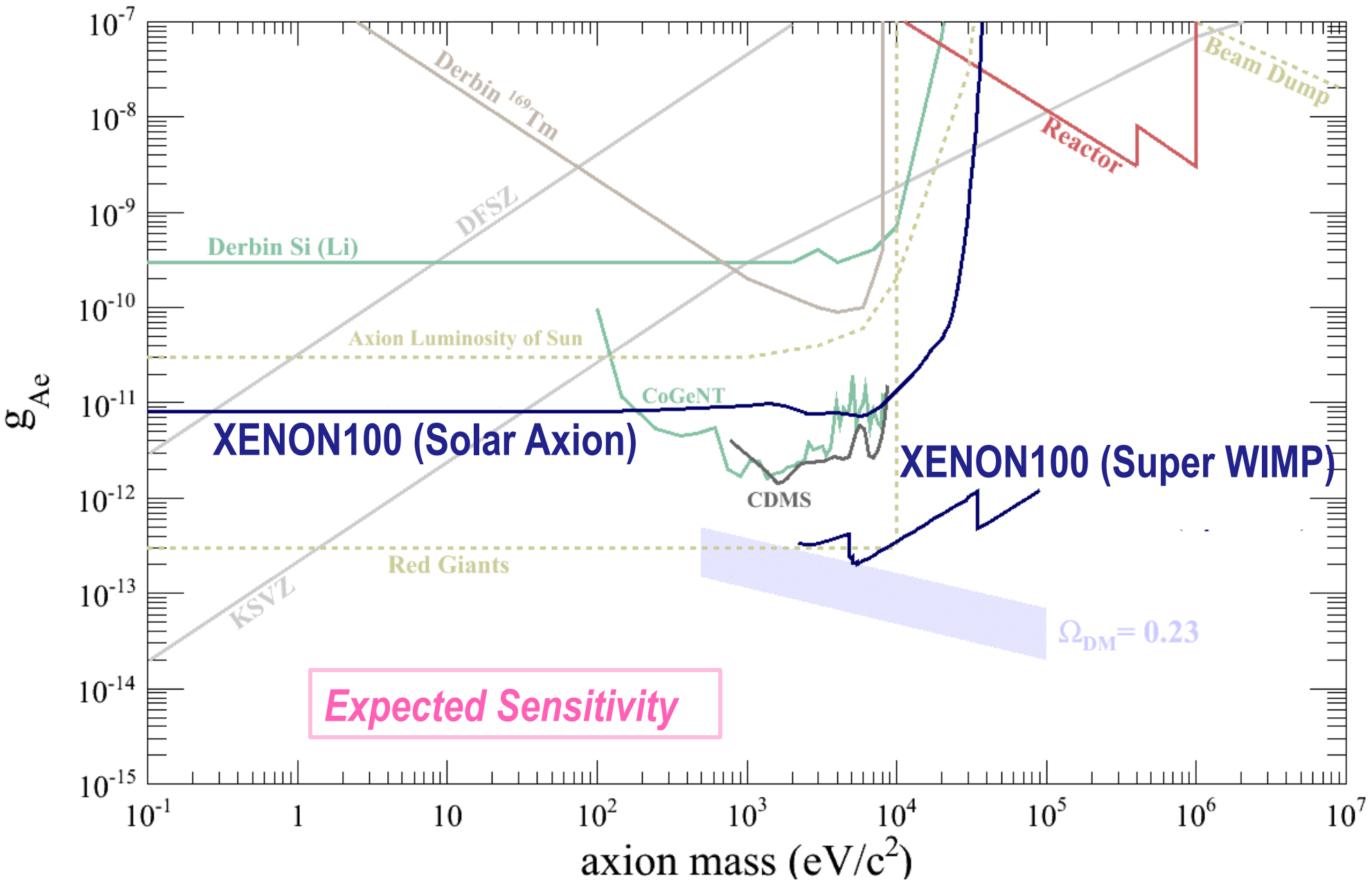

Comparison of Xenon Detector Size

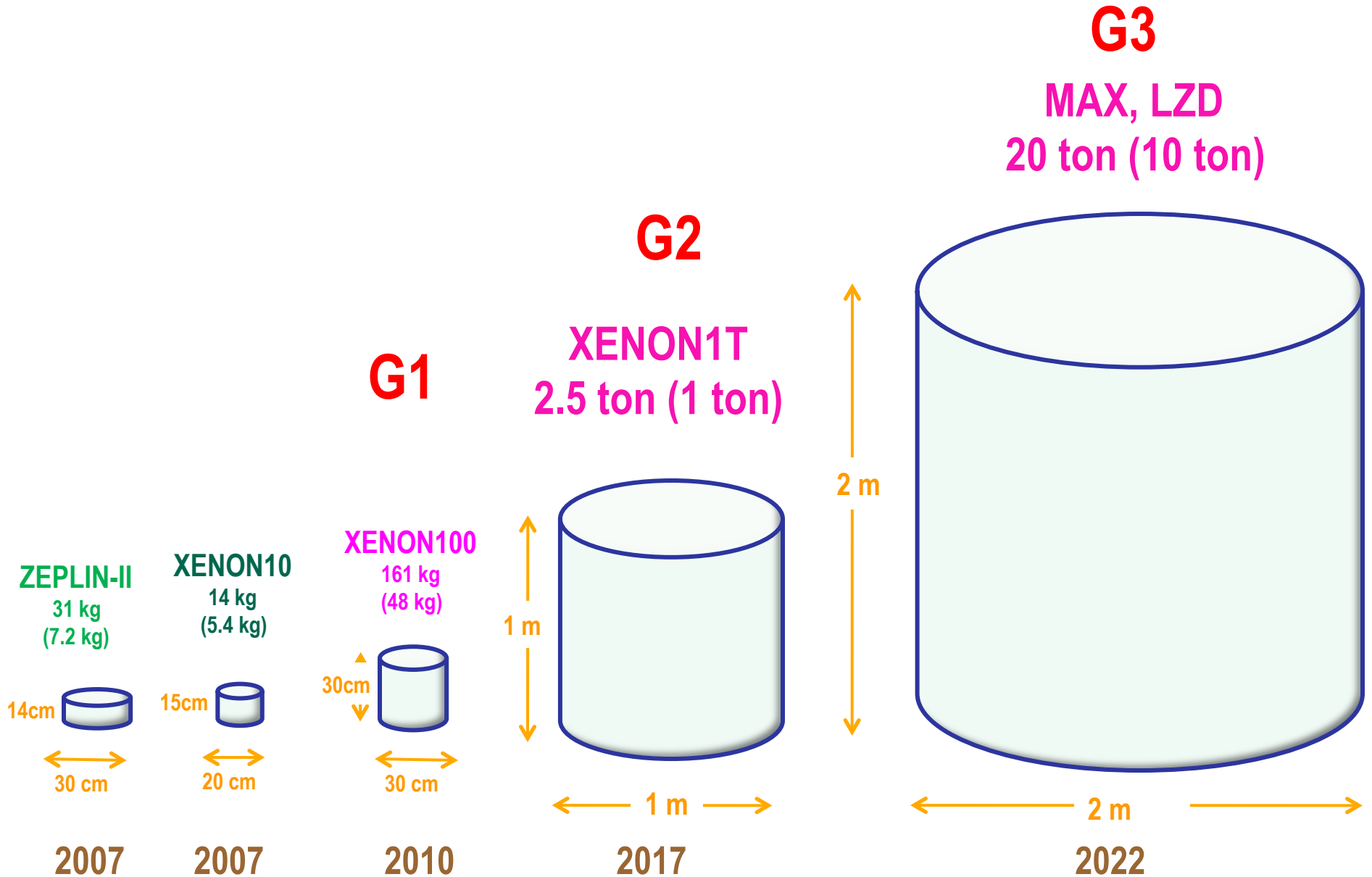

XENON 1T (G2) at Gran Sasso

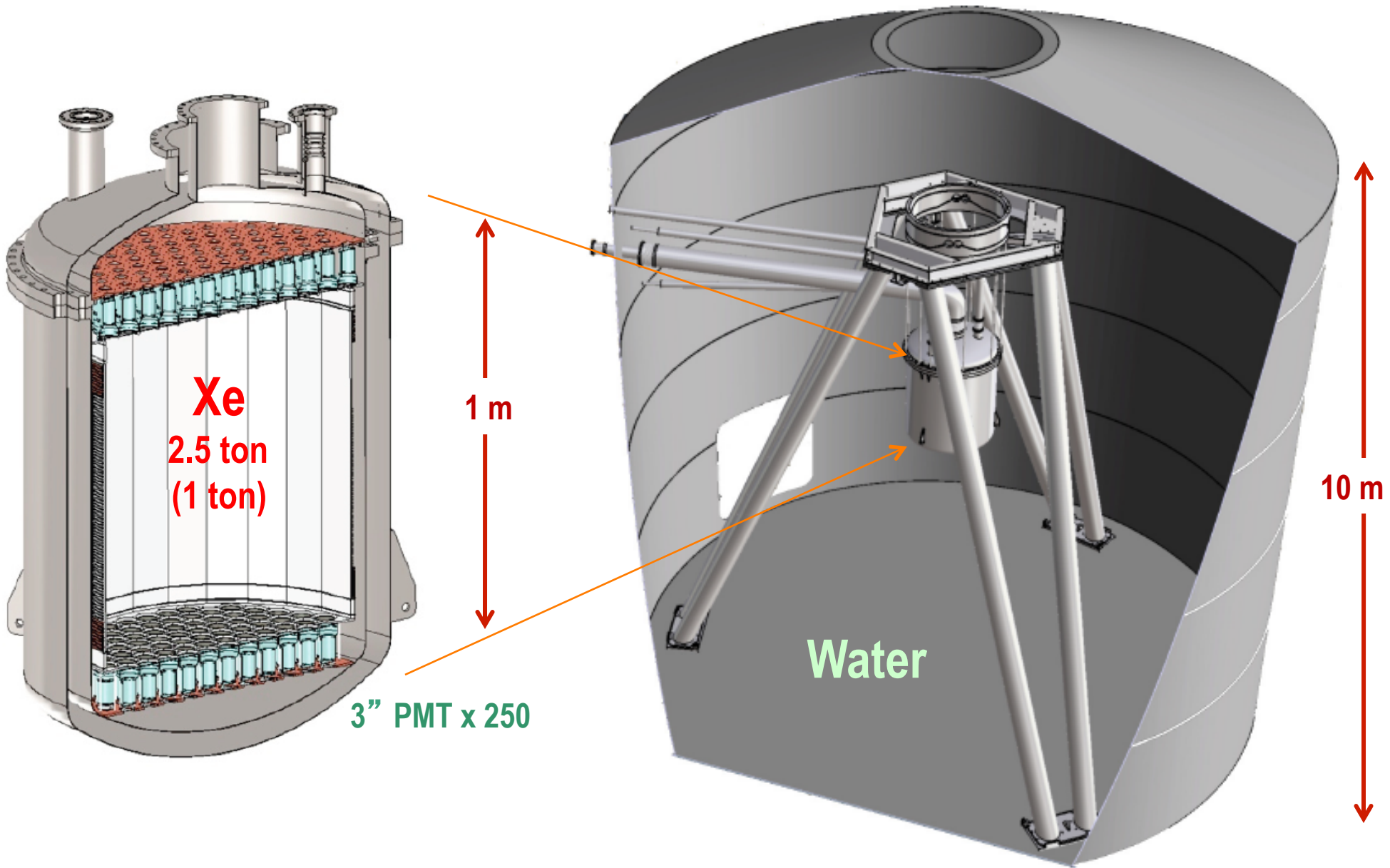

DarkSide 5T (G2) at Gran Sasso

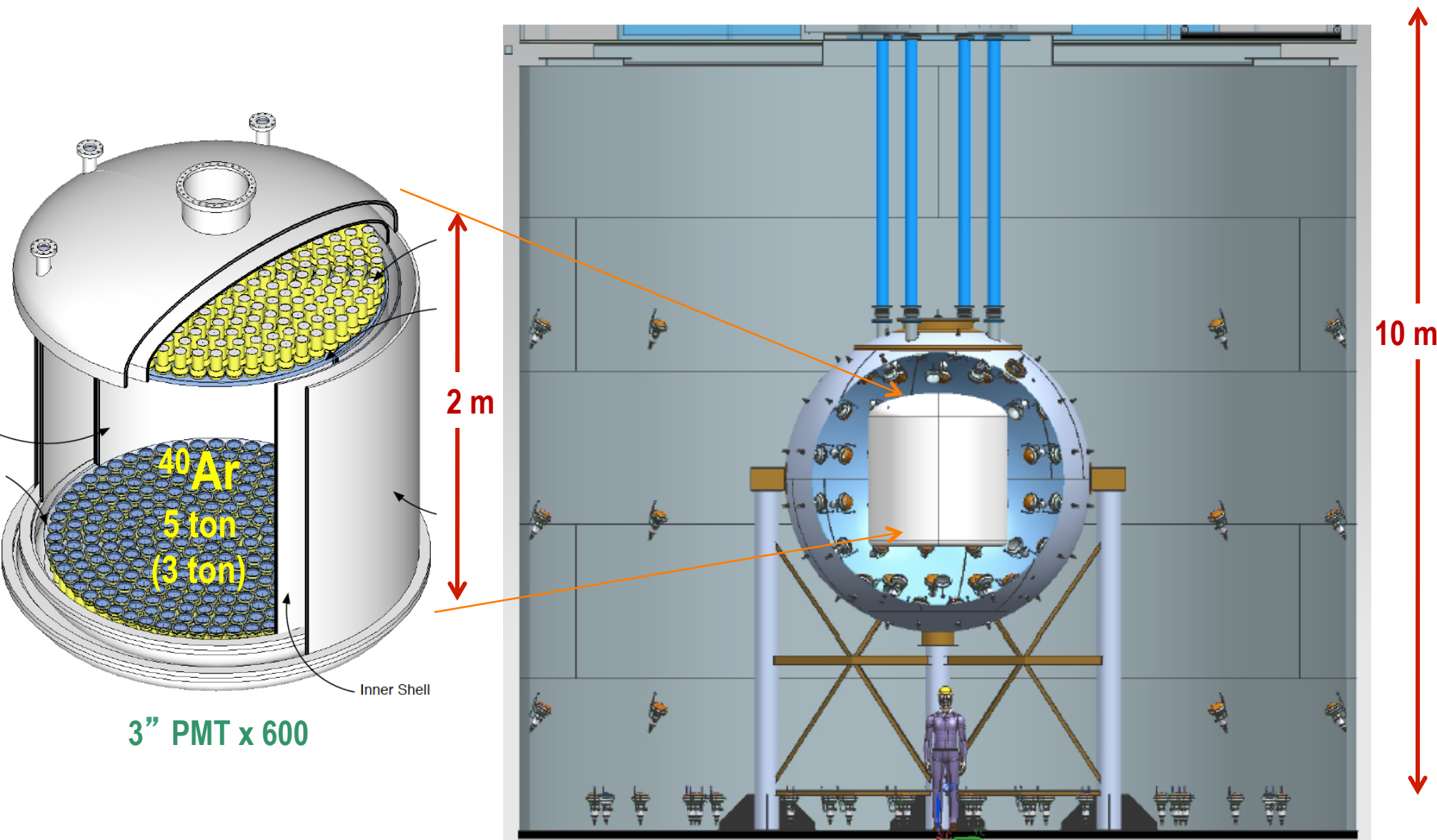

Roadmap to MAX

2012 2013 2014 2015 2016 2017 2018 2019 2020

Gran Sasso → DUSEL



G1

G2

G3

MAX+LZD = "Ultimate G3" Detector (at DUSEL)

Xe 20 ton (10 ton)

^{40}Ar 70 ton (50 ton)

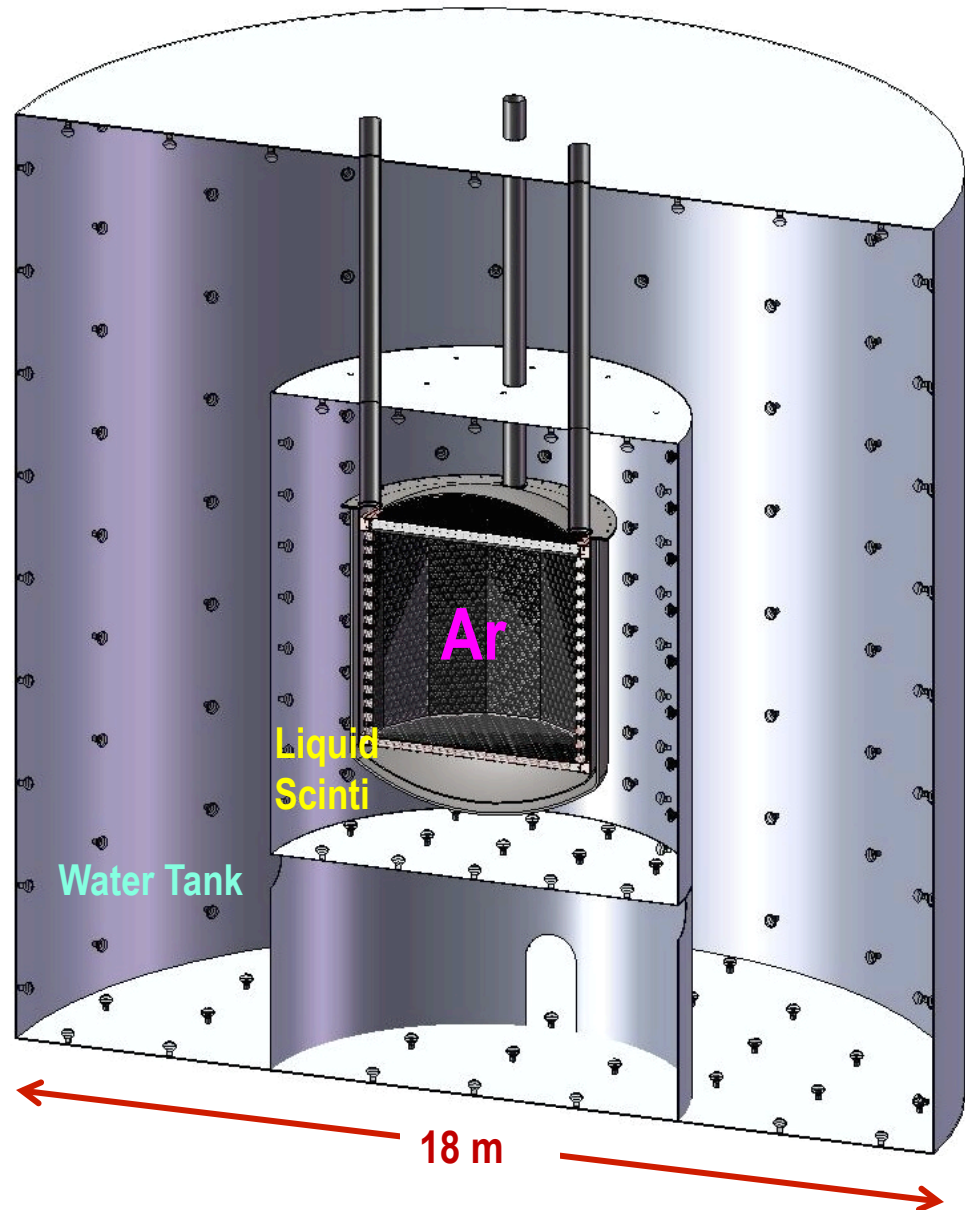
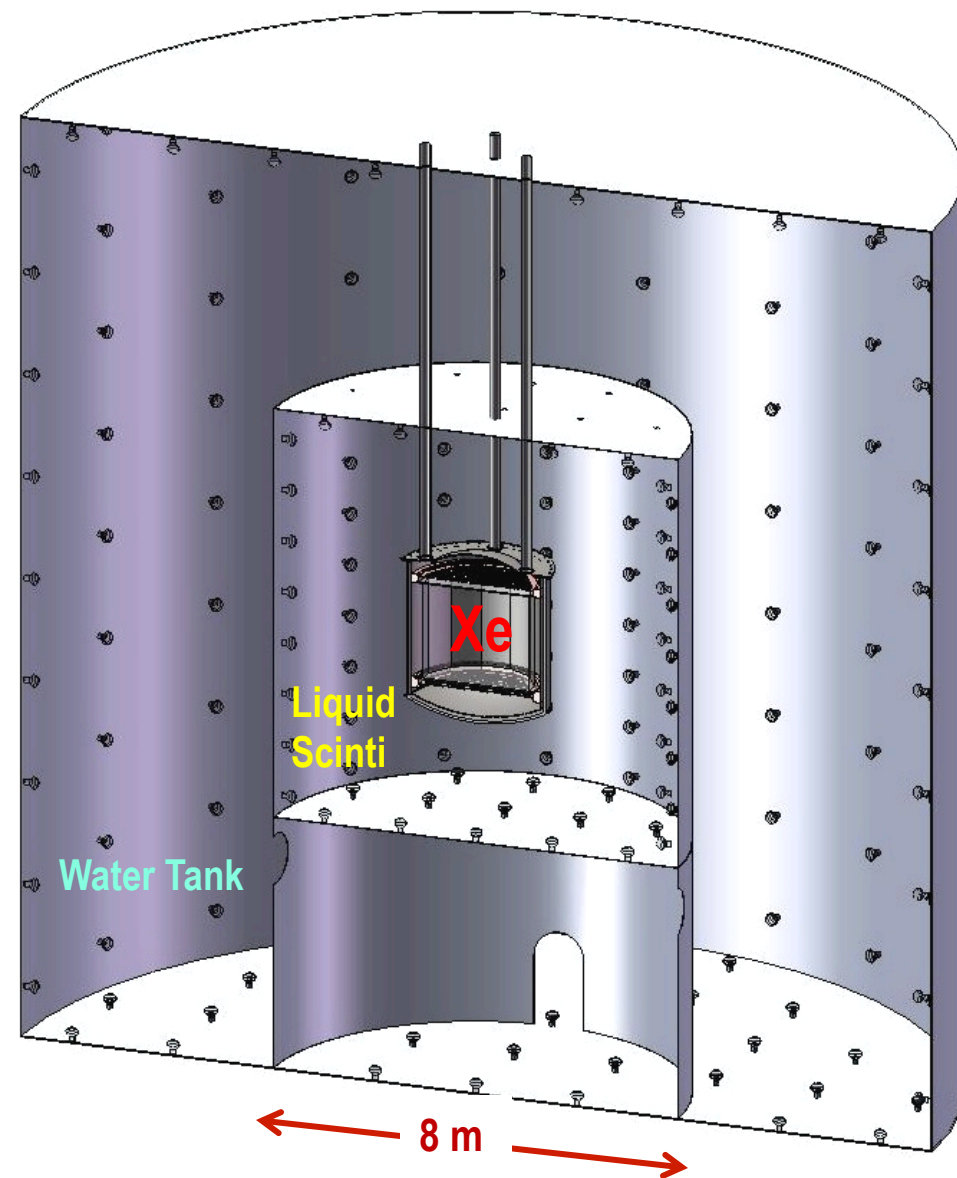

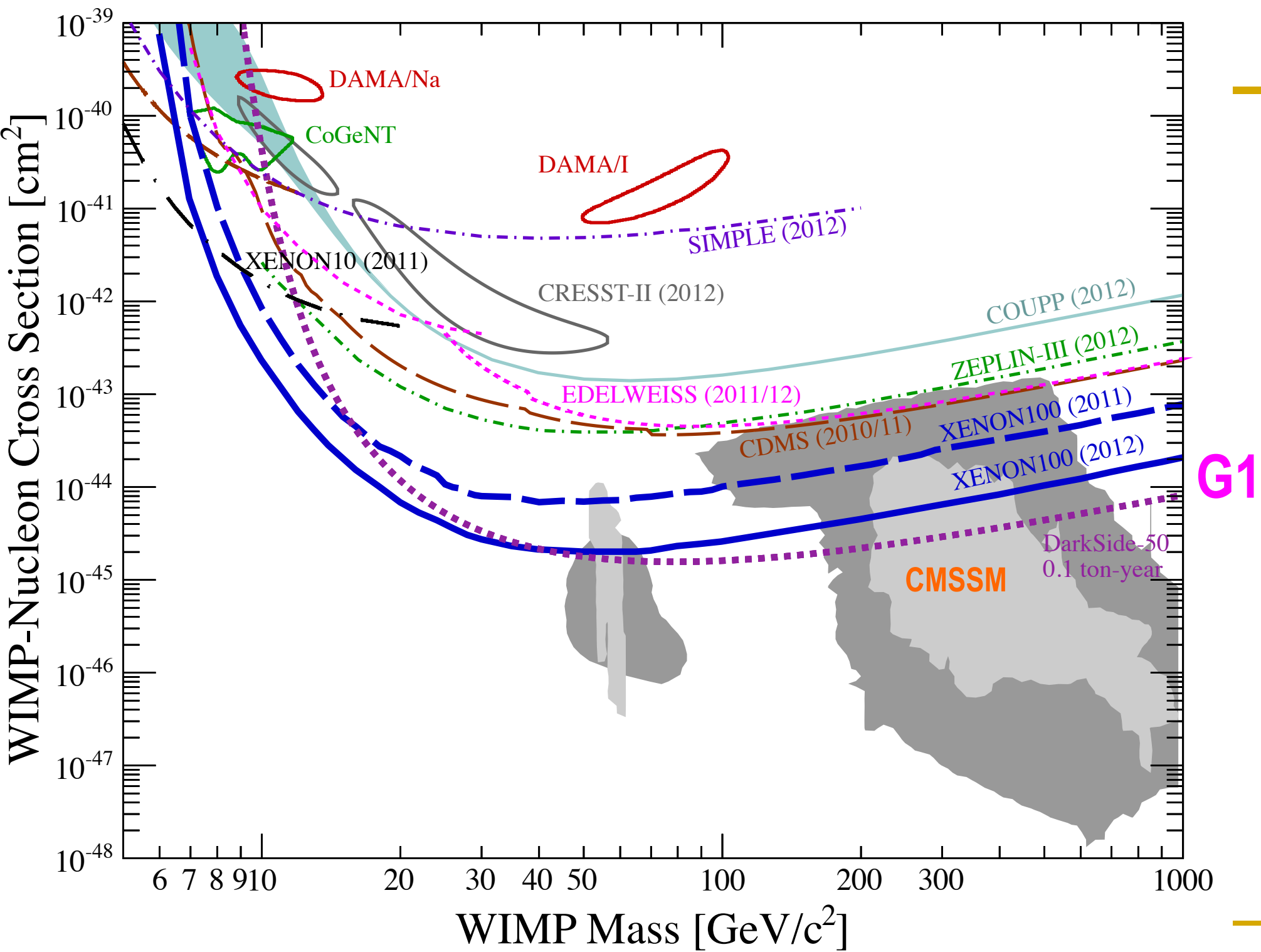

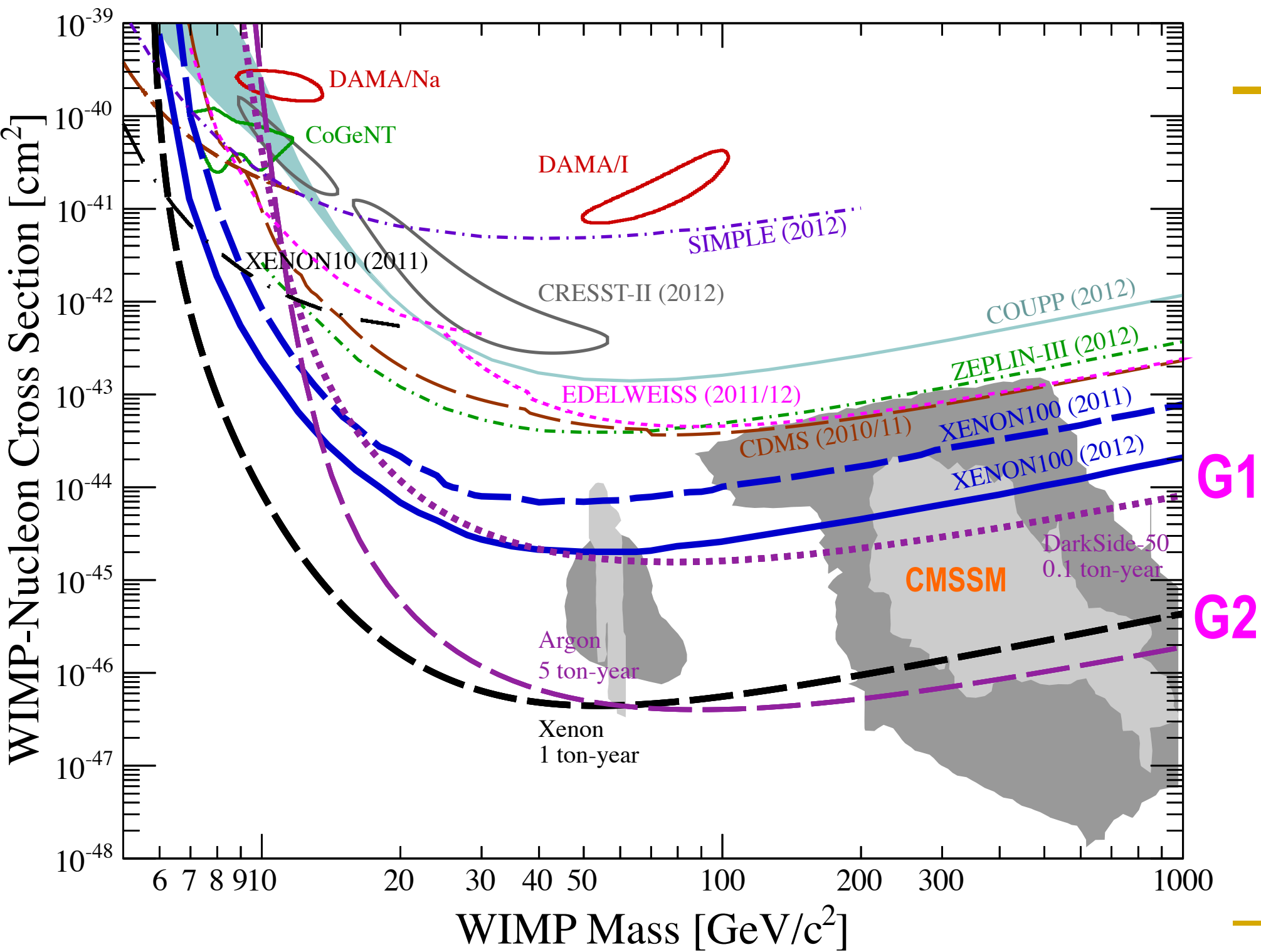

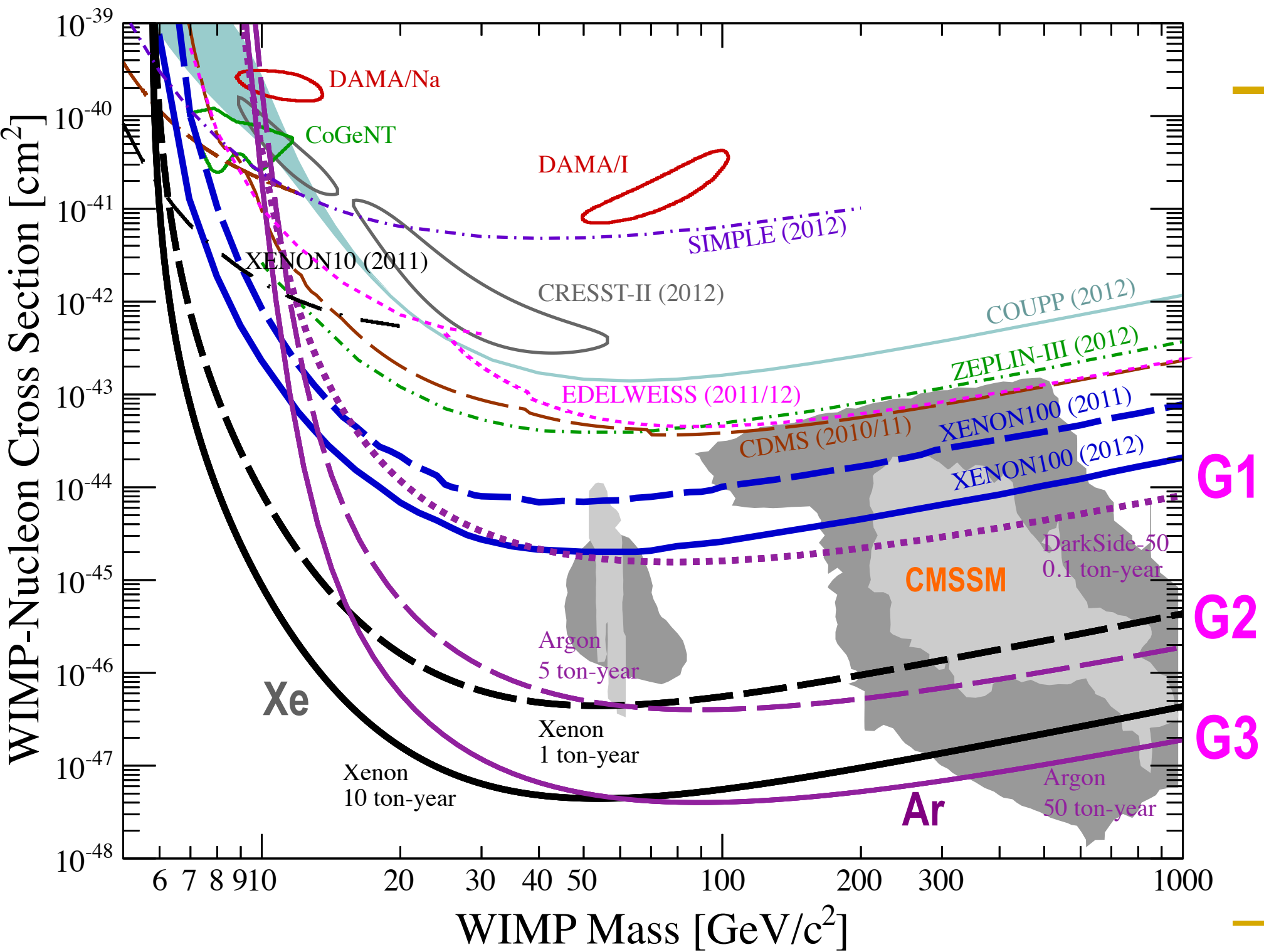

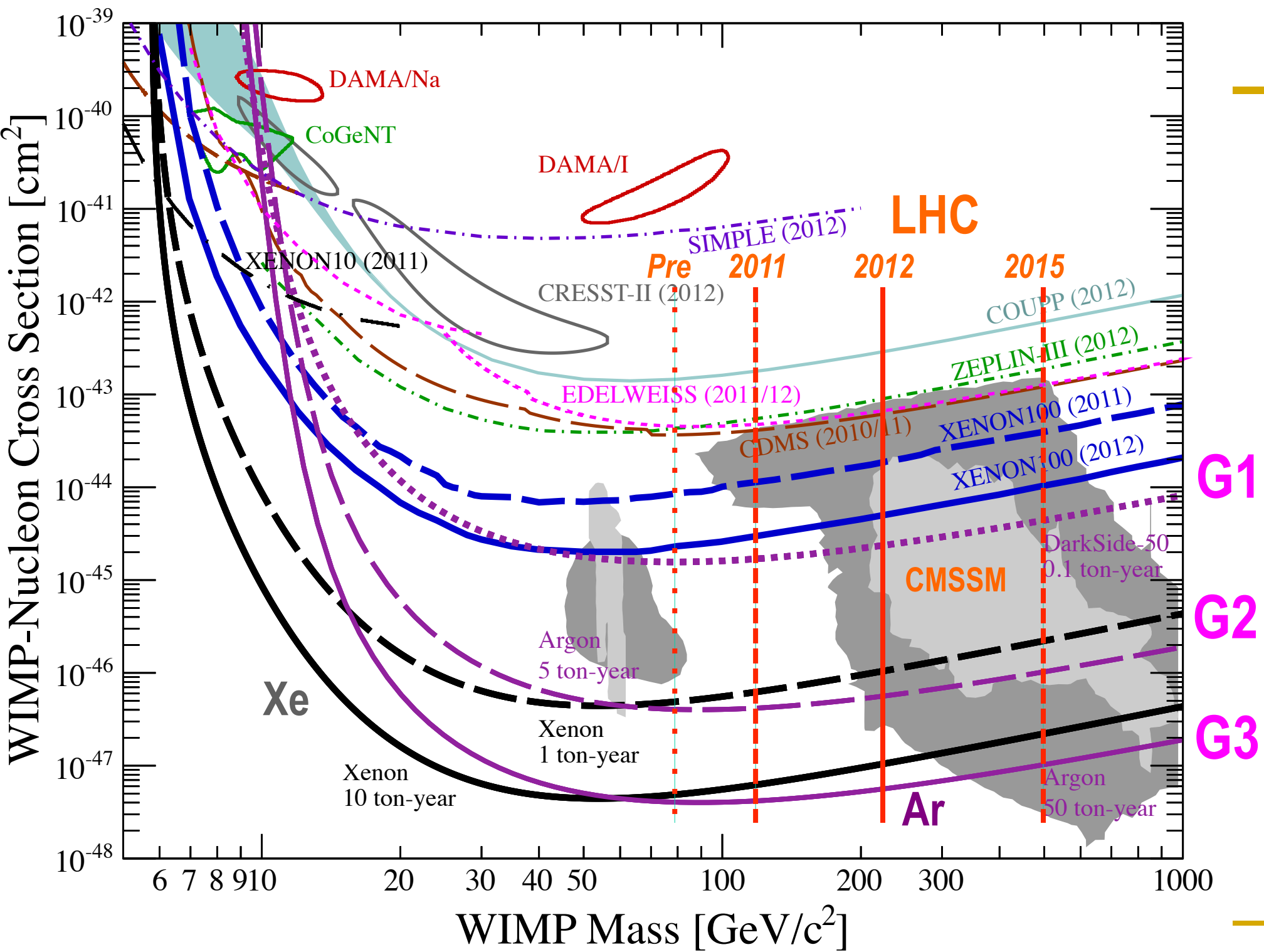

1- σ Error of WIMP Mass vs SI Cross Section (10 ton*year Xe and 50 ton*year Ar)

1- σ Error of WIMP Mass and SI Cross Section

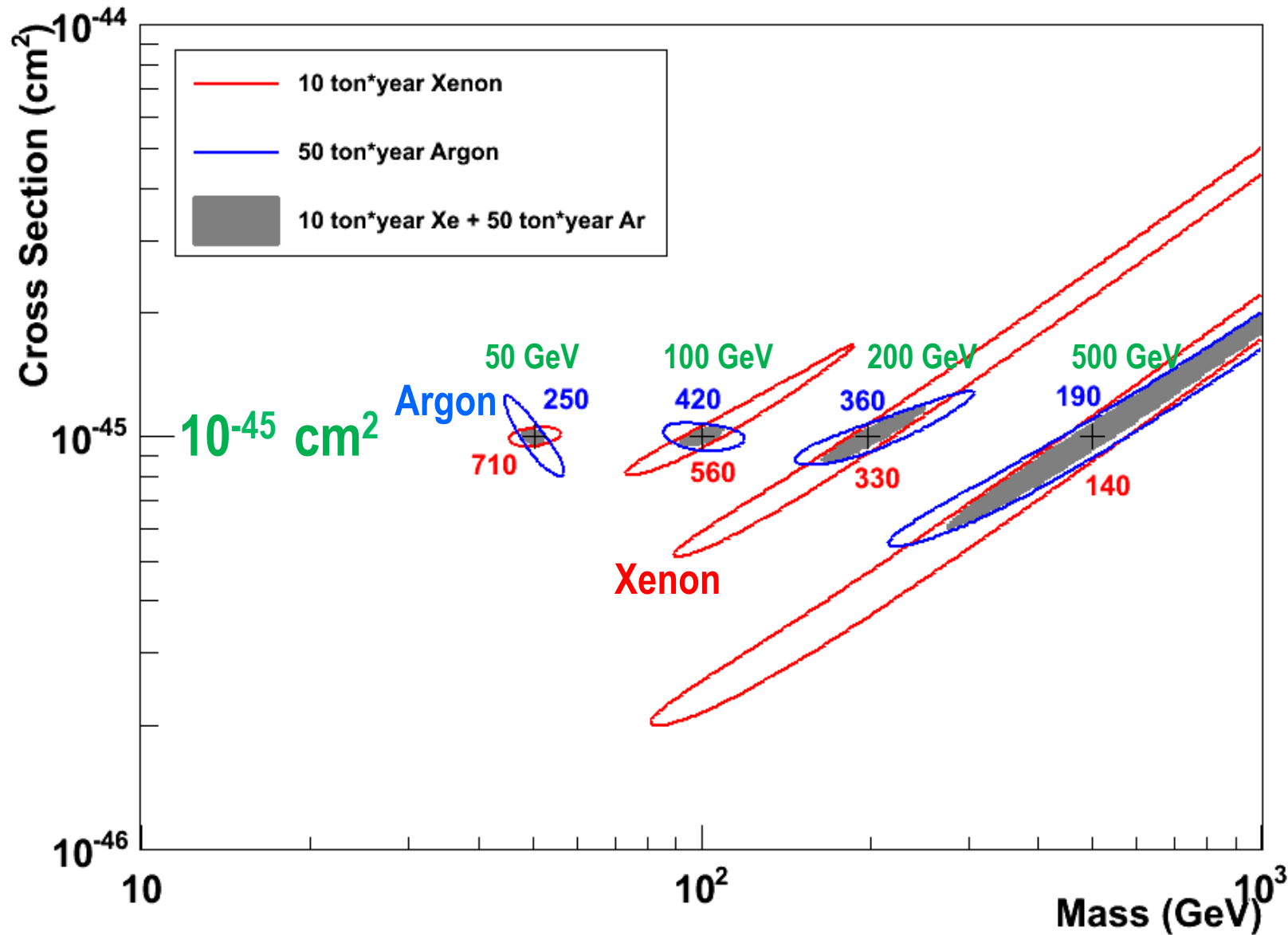

Where backgrounds come from?

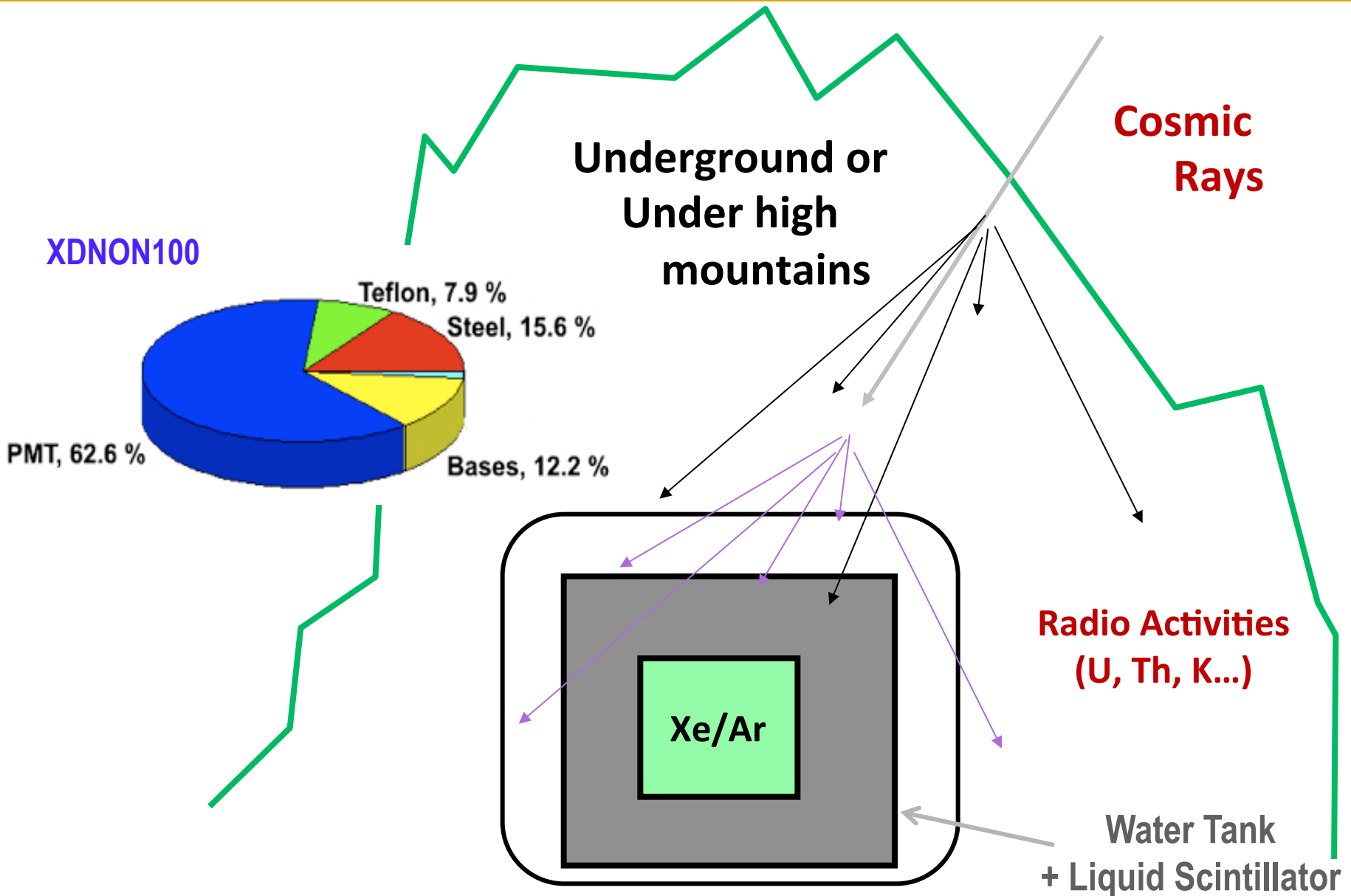

Photon detectors are the major source of backgrounds.

QUPID (QUartz Photon Intensifying Detector)

arXiv:1103.3689

Photo Cathode
(-6 kV)

Photo Cathode
(-6 kV)

Quartz

Al coating

APD (0 V)

Quartz

APD (0 V)

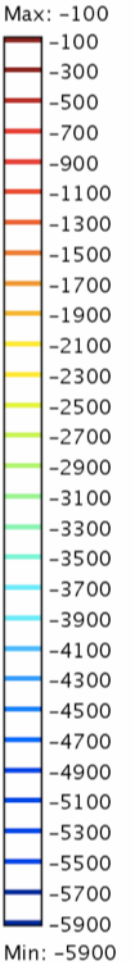

Comparison of Photon Detectors from Hamamatsu

R11065 (Ar)

R11410 (Xe)

3 inch

XENON1T

DarkSide50

QUPID

3 inch

MAX

XAX

R8520

1 inch

XENON10

XENON100

U/Th ~ 0.1 mBq

U/Th ~ 5 mBq

U/Th ~ 1 mBq

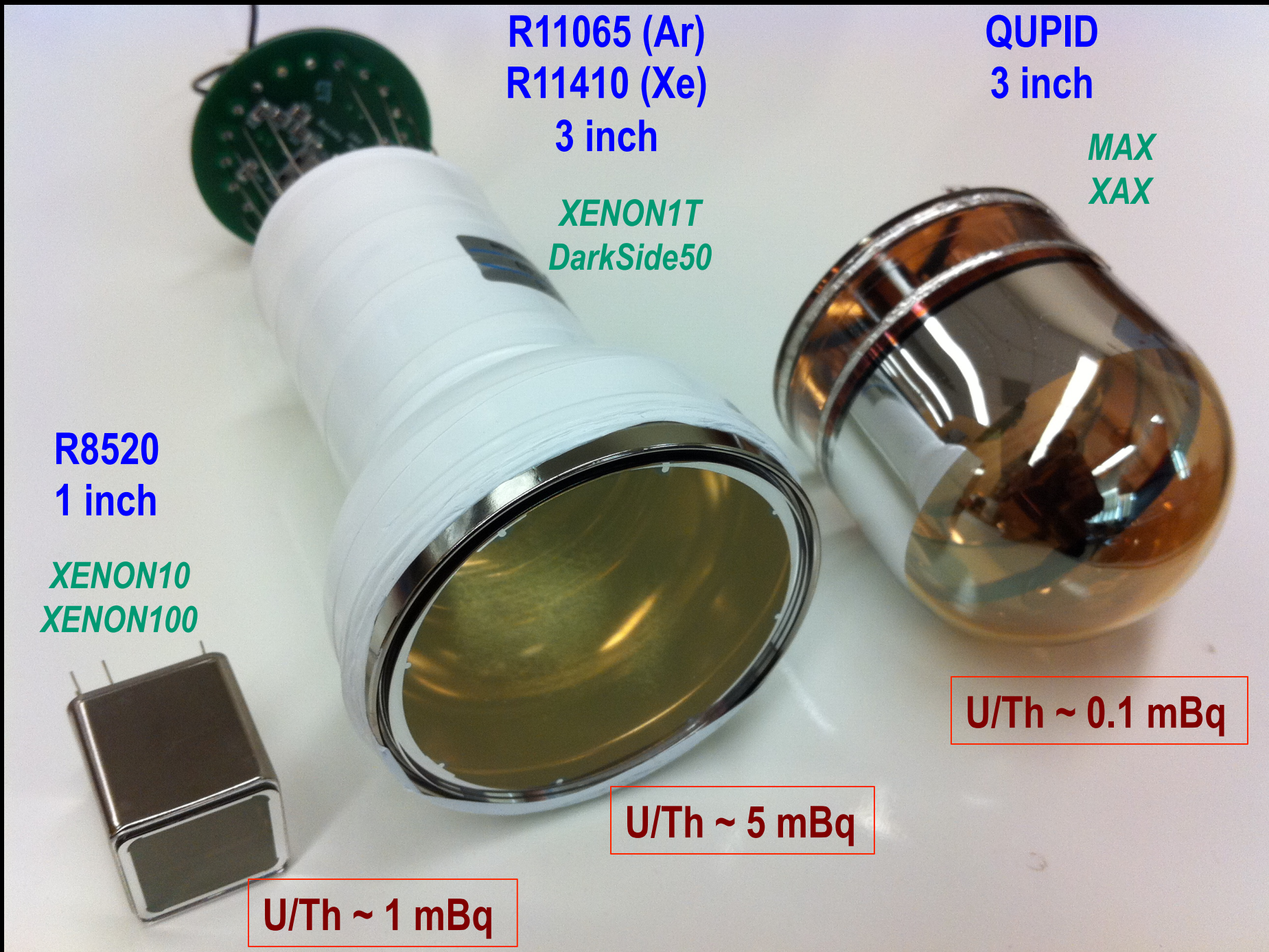

7 QUPID with Holder

Tested in both Xe and Ar



Hanguo Wang's Lab

Control Panel

Recirculation Rack

Xenon Bottle

Recirculation Pump

Getter

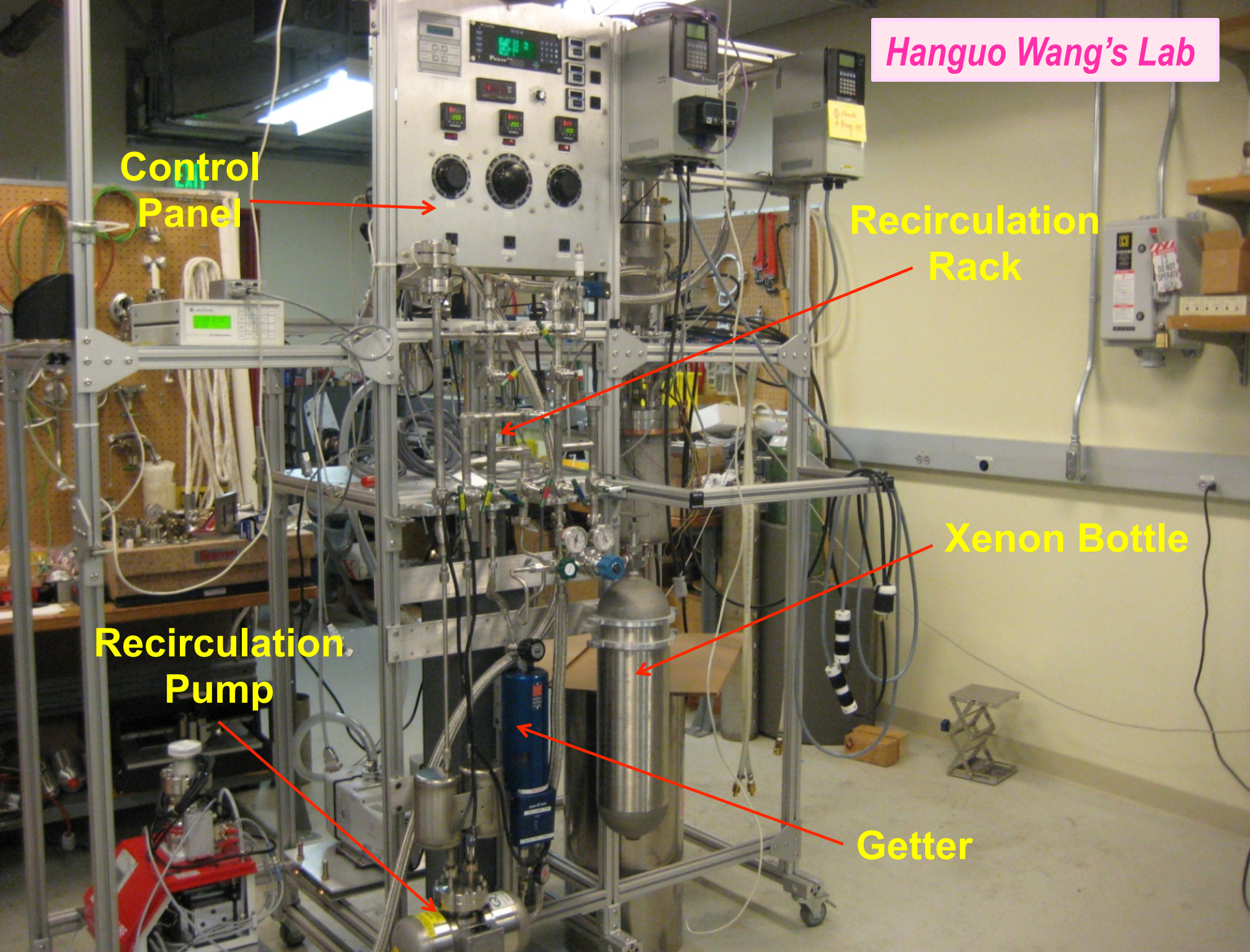

Technological Challenges

➤ External Backgrounds

- Deep underground
- > 5 m water shielding

- DUSEL 4850 ft
- Water Tank (15 m)

➤ Detector Materials

- Photon Detectors
- Cryostat
- Others

- QUPID
- Copper (OHFC)
- PTFE, Quartz ...

➤ Purity of Liquid Xe/Ar

- Radon (< 0.3 mBq / ton)
- ^{39}Ar (> 100 depletion)
- ^{85}K (< 0.2 ppt in Xe)

- Depleted Ar
- 1 event / 10 ton-year

➤ Physics Backgrounds in Xe

- pp-chain solar neutrinos
- 2v Double beta decays from ^{136}Xe

- 1 event / 10 ton-year
- 1 event / 10 ton-year

Conclusions

➤ Science Cases

- Overwhelming – Astronomy and Cosmology
- **Beyond Standard Model** – SUSY, Extra Dimensions...

➤ Experimental Status

- Healthy competition between LHC (\$10B) and XENON (\$10M)
- SUSY is pushed to the corner, or about to be discovered.

➤ Future Direct Searches

- G2 : **XENON 1T** and **DarkSide 5T** at Gran Sasso.
- G3 : MAX (**Xe 10T** + **Ar 50T**) at DUSEL

Katsushi's Speculations in Nov 2011

- **2012** **LHC (ATLAS+CMS) announces**
 - ~~120 GeV Higgs (at 3σ)~~
 - **125 GeV Higgs (at 5σ)**
- **2017** **XENON1T announces**
 - **Observation of 10 WIMP signals (> 200 GeV)**
- **2022** **G3 (Xe+Ar) and LHC jointly confirm**
 - **Extra Dimensions**
 - **WIMP = 700 GeV KK Photon ($\Delta = 5\%$)**
 - **No Supersymmetry**
 - **Katsushi happily retires at age 66.**