

OPERATOR'S MANUAL

**MODEL 4608C
8-CHANNEL NIM
DISCRIMINATOR**

June 1987

LeCroy

Innovators in Instrumentation

Corporate Headquarters

700 Chestnut Ridge Road
Chestnut Ridge, NY 10977-6499
Tel: (914) 425-2000, TWX: 710-577-2832

European Headquarters

Route du Nant-d'Avril 101
1217 Meyrin 1
Geneva Switzerland
Tel: (022) 82 33 55

CAUTION

COOLING

The high power dissipation of the 4608C requires that it be well cooled. It is suggested that NIM bin fan be used to maintain exhaust air temperature to less than 50°C.

6 V POWER REQUIREMENT

The 4608C uses significant power from -6 NIM power line. Be sure that your bin can supply enough current to this and other modules, especially if multiple 4608C's are to be used.

INSTALLATION

NIM bin power should be turned off during insertion or removal of modules to avoid possible damage caused by momentary misalignment of contacts.

SPECIFICATIONS

The information contained in this manual is subject to change without notice. The reference for product specification is the Technical Data Sheet effective at the time of purchase.

TABLE OF CONTENTS

1 General Information	
Purpose	1
Unpacking and Inspection	1
Warranty	1
Product Assistance	2
Maintenance Agreements	2
Documentation Discrepancies	2
Software Licensing Agreement	2
2 Product Description	
Overview	3
Specifications	4
Controls and Connectors	6
Updating Burst Guard Switch	9
3 Installation	
General	11
4 Operating Instructions	
General	13
Threshold	13
Minimum Input Charge	14
Output Width	15
Test Mode	15
5 Theory Of Operation	
Introduction	17

PURPOSE

This manual is intended to provide instruction regarding the setup and operation of the covered instruments. In addition, it describes the theory of operation and presents other information regarding its functioning and application.

The Service Documentation, packaged separately, should be consulted for the schematics, parts lists and other materials that apply to the specific version of the instrument as identified by its ECO number.

UNPACKING AND INSPECTION

It is recommended that the shipment be thoroughly inspected immediately upon delivery. All material in the container should be checked against the enclosed Packing List and shortages reported promptly. If the shipment is damaged in any way, please notify the Customer Service Department or the local field service office. If the damage is due to mishandling during shipment, you may be requested to assist in contacting the carrier in filing a damage claim.

WARRANTY

LeCroy warrants its instrument products to operate within specifications under normal use and service for a period of one year from the date of shipment. Component products, replacement parts, and repairs are warranted for 90 days. Software is thoroughly tested, but is supplied "as is" with no warranty of any kind covering detailed performance. Accessory products not manufactured by LeCroy are covered by the original equipment manufacturers warranty only.

In exercising this warranty, LeCroy will repair or, at its option, replace any product returned to the Customer Service Department or an authorized service facility within the warranty period, provided that the warrantor's examination discloses that the product is defective due to workmanship or materials and has not been caused by misuse, neglect, accident or abnormal conditions or operations.

The purchaser is responsible for the transportation and insurance charges arising from the return of products to the servicing facility. LeCroy will return all in-warranty products with transportation prepaid.

This warranty is in lieu of all other warranties, express or implied, including but not limited to any implied warranty of merchantability, fitness, or adequacy for any particular purpose or use. LeCroy shall not be liable for any special, incidental, or consequential damages, whether in contract, or otherwise.

PRODUCT ASSISTANCE

Answers to questions concerning installation, calibration, and use of LeCroy equipment are available from the Customer Services Department, 700 Chestnut Ridge Road, Chestnut Ridge, New York 10977-6499, (914) 578-6059, or your local field service office.

MAINTENANCE AGREEMENTS

LeCroy offers a selection of customer support services. For example, Maintenance agreements provide extended warranty that allows the customer to budget maintenance costs after the initial warranty has expired. Other services such as installation, training, on-site repair, and addition of engineering improvements are available through specific Supplemental Support Agreements. Please contact the Customer Service Department or the local field service office for details.

DOCUMENTATION DISCREPANCIES

LeCroy is committed to providing state-of-the-art instrumentation and is continually refining and improving the performance of its products. While physical modifications can be implemented quite rapidly, the corrected documentation frequently requires more time to produce. Consequently, this manual may not agree in every detail with the accompanying product and the schematics in the Service Documentation. There may be small discrepancies in the values of components for the purposes of pulse shape, timing, offset, etc., and, occasionally, minor logic changes. Where any such inconsistencies exist, please be assured that the unit is correct and incorporates the most up-to-date circuitry.

SOFTWARE LICENSING AGREEMENT

Software products are licensed for a single machine. Under this license you may:

- Copy the software for backup or modification purposes in support of your use of the software on a single machine.
- Modify the software and/or merge it into another program for your use on a single machine.
- Transfer the software and the license to another party if the other party accepts the terms of this agreement and you relinquish all copies, whether in printed or machine readable form, including all modified or merged versions.

OVERVIEW

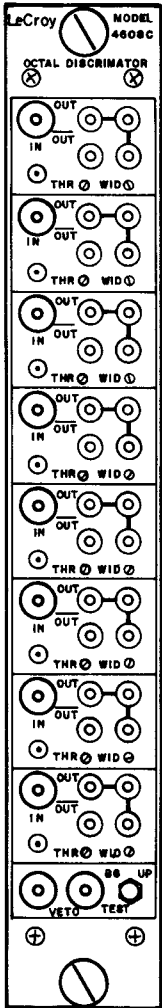

Figure 1
Front Panel Layout

The LeCroy Model 4608C is an eight input discriminator in a single width NIM module. This unit has selectable Updating or Burst Guard operation. In addition, a VETO and TEST input are provided which are common to all channels. The unit offers three NIM bridged outputs, as well as one complementary output per channel. Output widths are adjustable for each channel from 3.5 nsec to 100 nsec. Figure 1 shows the layout of the front panel.

Individual thresholds are set by front-panel potentiometers which can be read by a voltmeter at the test points. The threshold range extends from -15 mV to -1 V. The low minimum threshold of the 4608C makes it possible to use lower gain photomultipliers, lower high voltage in the phototubes, and to drive PM signals over longer cable lengths than would be possible with higher thresholds. In addition, the low minimum threshold permits back-termination at the photomultiplier to absorb reflections and high amplitude noise. (In this case, the PM drives 25Ω , the tube current is shared, and the amplitude is half that of the unterminated system).

The high density is made possible through extensive use of hybrid circuits. Except for a few external components, two discriminator channels are contained in a single HVL210 hybrid. The use of hybrid circuits is dictated by the sophisticated technique needed for 150 MHz discriminators.

SPECIFICATIONS

Input Characteristics

Signal Inputs: eight inputs via Lemo front-panel connectors, $50\ \Omega \pm 2\%$, protected to $\pm 5\ \text{A}$ for $0.5\ \mu\text{sec}$, clamping at $\pm 5\ \text{V}$. Reflections $< 4\%$ for input pulses of $2\ \text{nsec}$ risetime. Stability better than $0.25\%/^{\circ}\text{C}$ to 60°C operating range. Offset $\pm 3\ \text{mV}$.

Threshold: $-15\ \text{mV}$ to $-1\ \text{V} \pm 5\%$ or $5\ \text{mV}$ whichever is greater.

Threshold Monitor: front-panel test point has 1:1 ratio of monitor voltage to actual voltage $\pm 5\%$.

Hysteresis: typical $3.5\ \text{mV}$.

Test Input: one input via a Lemo connector on the front panel, $50\ \Omega \pm 2\%$. Requires NIM level direct coupled signal ($< -600\ \text{mV}$) to trigger all channels. Minimum width: $3\ \text{nsec}$. Maximum rate: $150\ \text{MHz}$.

Veto Input: one input via a Lemo front-panel connector, $50\ \Omega \pm 2\%$, permits simultaneous fast inhibiting of all channels; requires NIM level signal ($< -600\ \text{mV}$). Direct coupled. Must precede input signal by approximately $1\ \text{nsec}$ and overlap its leading edge in Updating mode or overlap complete input signal in Burst Guard mode. Minimum duration: $3\ \text{nsec}$.

Output Characteristics

Negative Outputs: three bridged outputs, $0\ \text{mA}$ quiescently, $-50\ \text{mA}$ during output, ($-800\ \text{mV}$) into three $50\ \Omega$ loads. Amplitude limited to $-1.2\ \text{V}$. Duration $3.5\ \text{nsec}$ to $> 100\ \text{nsec}$. Risetimes and falltimes less than $2\ \text{nsec}$. Width stability better than $0.3\%/^{\circ}\text{C}$ max.

Complementary Output: one output, $16\ \text{mA} \pm 2\ \text{mA}$ quiescently, $0\ \text{mA}$ during output. Duration, risetimes, falltimes, and width stability specifications are identical to those of negative outputs.

Timing Characteristics

Double Pulse Resolution: $5\ \text{nsec}$ typical.

The speed of a discriminator is practically defined by its double pulse resolution or the time between the leading edges of the most closely spaced pulse pairs for which the discriminator produces two distinct output pulses. Although simple in concept, this specification can be misleading unless the input conditions are precisely defined and ambiguities in performance are disclosed. One should indeed investigate the double pulse resolu-

tion as function of the input amplitude over threshold and of the input width.

Tracking Error: Tests on the 4608 show a tracking error typically not in excess of 200 psec.

The ability of a discriminator to be used for precise timing (coincidence or TOF) in an environment which encounters narrow pulse pair separations is demonstrated by considering the time shift (or tracking error) introduced as the time interval between successive inputs is reduced. In an experiment, tracking error is equivalent to time dispersion as a function of input rate. For many experiments, this error can be critical, since it is often in high rate situations that the best timing resolution is required.

Time Slewing: <500 psec for input amplitudes from 2 times to 20 times over threshold. See Figure 2.

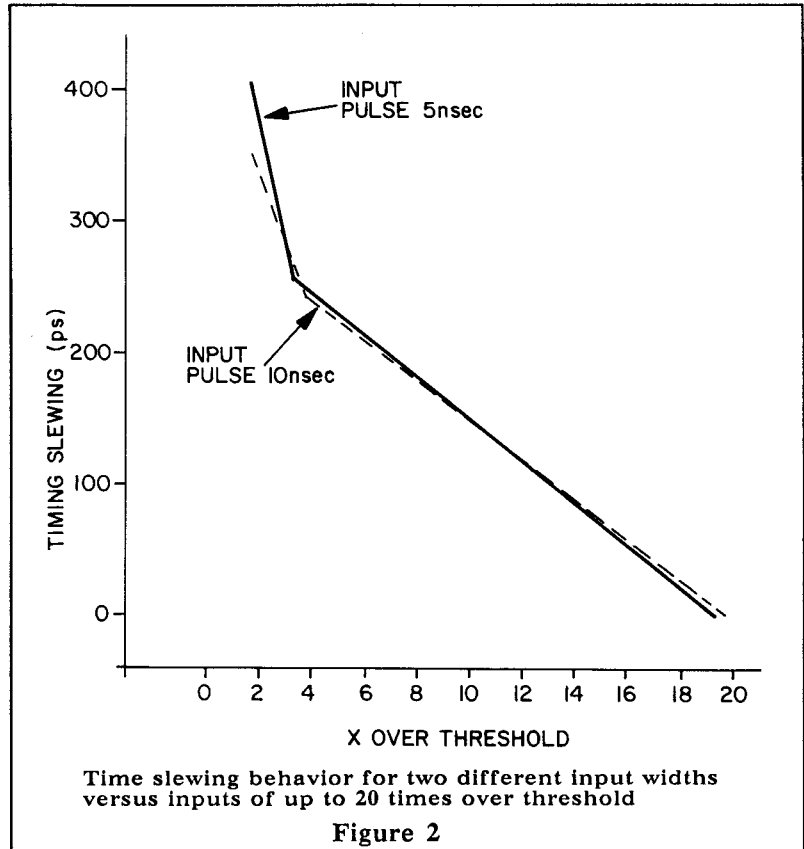

Slewing is the variation in propagation delay from the beginning of the pulse input to the output pulse as a function of input pulse amplitude. The intrinsic slewing is measured as a function of input crossing threshold to output pulse. In addition, pulses of varying risetimes give different delays from the beginning of the pulse since the threshold crossing time relative to the pulses leading edge depends upon the amplitude of the pulse. Only the intrinsic slewing is specified for the Model 4608C since risetime slewing is application dependent.

Slewing is typically measured as the difference between propagation delay for input pulse amplitudes twice that of threshold and input pulses whose amplitudes are 20 times threshold. Threshold is defined as the input pulse level which results in discriminator firing for 50% of the pulses.

General

Maximum Rate: 150 MHz.

Input-Output Delay: <18 nsec.

Test-Output Delay: <18 nsec.

Multiple Pulsing: None; one and only one output pulse is produced for each input pulse regardless of input pulse amplitude and duration.

Burst Guard™: A front-panel switch enables the Burst Guard or Updating operation for all channels.

Power Requirements:

+24 V	at 0.01 A
+6 V	at 0.6 A
-6 V	at 2.1 A

CONTROL AND CONNECTORS

Signal Input

Signal input to each of the eight channels is made via a front-panel Lemo connector. The inputs of the 4608C discriminator are protected to 5 A for 0.5 μ sec, clamping at ± 5 V.

The DC protection is limited by the 0.25 W dissipation limit of the input resistor, which can be assumed to offer protection against DC signals less than 5 V.

Input reflections for the 4608C are less than 4% with 2 nsec input pulses.

Threshold

The threshold range of the 4608C Octal Discriminator is from -15 mV to -1 V. Each input channel is adjustable by a front-panel, 15-turn potentiometer. The adjustment is uniform and

does not present any discontinuity or changes in sensitivity. Threshold is increased by turning the control clockwise.

A front-panel test point is a 1:1 monitor of the actual threshold value within $\pm 5\%$. The output impedance of the test point is 10 k Ω , so a high impedance digital voltmeter should be used.

Test Input

A front-panel Test input allows all channels to be triggered once a negative NIM pulse is received. This useful feature allows complete testing of the module without removing any input cable and also permits the use of the 4608C as a 24-fold negative fan-out and 8-fold complementary fan-out. The Test pulse will have the same effect as a similar pulse on the normal inputs. In particular, the output width in Burst Guard mode will be proportional to the input width.

Veto Input

A common front-panel Lemo input connector allows vetoing of all channels simultaneously when a negative NIM pulse is applied. A complementary NIM signal applied to the Veto input permits the 4608C to be used as an 8-channel strobed coincidence unit. In other words, the discriminators will generate an output only when the input level exceeds the set threshold and while these signals occur during a logical 0 (≥ -100 mV) state of the complementary input to the Veto.

However, the action of the Veto input can be different depending on the operation mode of the unit (Updating or Burst Guard) and on the static level of the Veto input (see Figure 3).

Updating mode: In the Updating mode, the leading edge of the input pulse triggers the discriminator timing stage. A Veto input must be coincident and precede the input pulse leading edge by 1 nsec for the input to be inhibited.

Burst Guard mode (time over threshold): When the Burst Guard section is enabled an overlap coincidence between the discriminator output and the Veto pulse is activated. A negative Veto pulse of the same width as the discriminator output will Veto the output during this time. If a pulse wider than the Veto pulse is applied at the input, an output will result due to the part of the pulse exceeding the Veto. Therefore an efficient Veto should completely overlap the input pulses.

The same applies when a complementary NIM Veto pulse is used to gate or enable the module. The gate pulse should completely overlap the input pulses. In this case the unit is working as a strobed overlap coincidence unit.

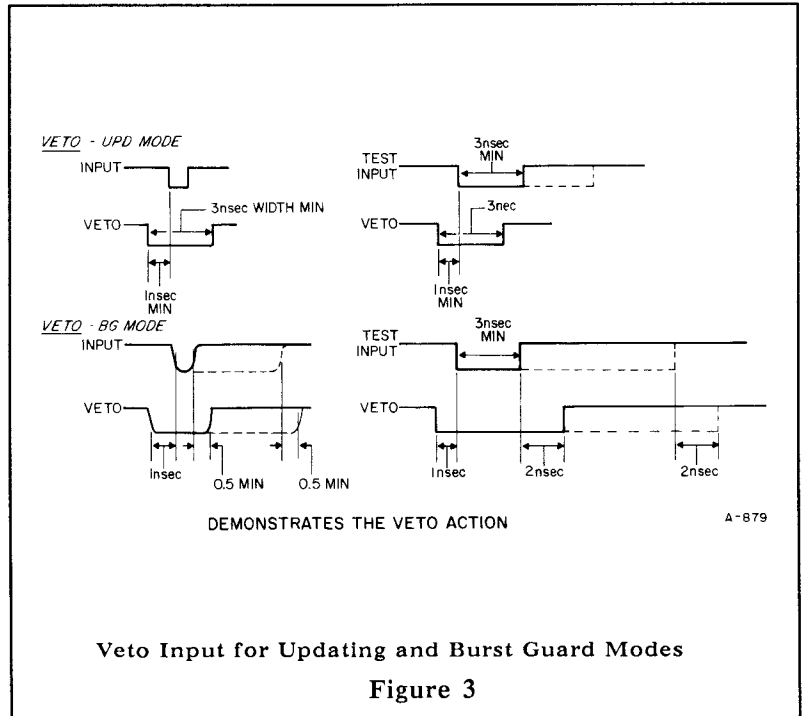

Output

Three bridged negative NIM outputs are available via front-panel Lemo connectors. These outputs have a 0 mA quiescently and -50 mA dynamic level into three 50 Ω loads. The actual output level therefore depends on the number of outputs or terminators connected.

Outputs normally have an overshoot which does not exceed the 15% of the pulse amplitude. The risetime and falltime are typically ≤ 2 nsec. In addition, a complementary output is provided for each channel via front-panel Lemo connectors. It is a 50 Ω output with quiescent level at -16 mA and logical 1 at 0 mA. Risetime and other characteristics are similar to that of the negative outputs.

Width Adjustment

The output width is independent for each channel and is continuously adjustable via front-panel potentiometers from 3.5 nsec to >100 nsec in the Updating mode. Minimum width is set by turning the pot fully counter clockwise.

The main contributors to output width uncertainty are a function of the external conditions. Variations in both temperature and supply voltage can cause significant changes in output width.

Width temperature coefficient has been measured to be $<0.3\%/^{\circ}\text{C}$ while the voltage coefficient is negligible because of the onboard stabilization of the current at -5.3 V .

UPDATING/BURST GUARD SWITCH

The module has a front-panel switch which allows the selection of the operational mode. See Figure 4 for a comparison.

Updating

In Updating mode, the output is extended if a second pulse arrives before the first output returns to zero, as long as the second pulse arrives at a time later than the double pulse resolution of the unit. Thus, the second pulse will be seen by the front end of the unit even though an output pulse is still present from the first signal. The second pulse will cause a new output to be generated and added (in time) to the portion of the original output already occurring.

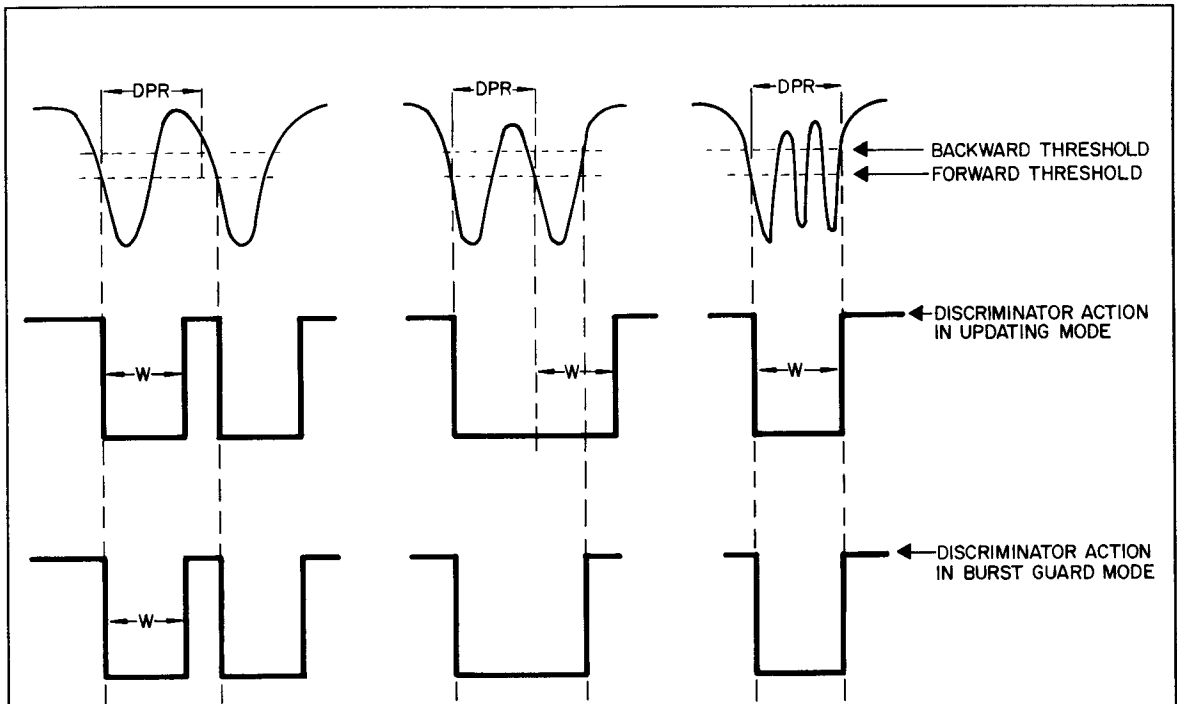

COMPARISON OF UPDATING AND BURST GUARD MODES WITH VARIOUS FAST INPUT SIGNALS. DPR IS THE DOUBLE PULSE RESOLUTION INTERVAL AND W SELECTED OUTPUT WIDTH WHICH IS SET TO MINIMUM IN THIS EXAMPLE.

A-880

Figure 4

Burst Guard

In Burst Guard mode, the output of the front end is OR'd with the conventional mode output. For input pulses arriving at a rate which exceeds the double pulse resolution of the unit, the discriminator output duration will be equal to the time interval between the first leading edge threshold crossing and the last trailing edge threshold recrossing or the preset output width, whichever is greater. This feature is especially important in veto applications when the discriminator output must be enabled as the detector is hit by unwanted and unmeasurable high rates. A discriminator without Burst Guard would see the first pulse and generate the preset output width, but would be paralyzed at quiescent level or would trigger only randomly for subsequent pulses separated by less time than the DPR of the unit. Burst Guard assures a logical 1 output level during these high rate bursts.

Burst Guard mode is also useful in any application where the output width has to be proportional to the input width.

GENERAL

The 4608C requires significant power from the -6 V line. It should be determined prior to installation whether the bin can support one or more 4608C's with other modules which are to be installed in the bin.

Once the unit is installed in the bin, input signals must be applied to the front-panel connectors. Then the threshold and output width must be adjusted via the front-panel potentiometers. The threshold can be monitored via a front-panel test point with a voltmeter. The output of this connector is a 1 to 1 ratio with the actual applied threshold voltage level.

In addition, the VETO signal must be connected to the 4608C if required, as is the TEST signal if desired. Of course, the output of the 4608C must be connected to associated units.

The 4608C provides three negative NIM outputs and one complementary NIM output. The negative outputs are bridged and all are generated from the same differential type current source, providing 0 mA statically and -48 mA dynamically, into three 50Ω loads. The output pulse height can vary then, depending from the number outputs used, from -0.7 V to -1.2 V. Therefore, if only one output of single NIM level is desired, the other connectors must be terminated with 50Ω terminators.

GENERAL

Setup of the 4608C can be split into three categories: adjustment of the threshold and output width and initiating the Test mode.

THRESHOLD

The main function of the discriminator is to generate a logic pulse output when the input exceeds a given threshold. Therefore, correct adjustment of the threshold is one of the most important duties to be performed.

The threshold is adjusted via front-panel potentiometers. The resulting change in threshold level is monitored with a high impedance voltmeter connected to the front-panel test points. The threshold can be set at some level which corresponds to a physical quantity (i.e., 100 mV may equal 100 keV) or it can be set above the noise level depending on the application. In either case, it is necessary to determine the level that the threshold should be set to. This action may be as easy as measuring the maximum noise level input or as complex as calibrating the system by accurately determining the relationship between pulse height (voltage level) and some quantity.

There are several phenomena to be aware of when setting the threshold since the actual value can be a function of environmental conditions as well as internal properties of the module itself.

Threshold Uncertainty

The external factors with the strongest effect upon the threshold value are the temperature coefficient of threshold and the power supply coefficient of threshold. Combining these, the actual threshold value V_T is given by:

V_T : Threshold according to front-panel control setting \pm DC offset \pm temperature coefficient X temperature change from calibration temperature \pm supply coefficient X voltage change from nominal supply voltage.

For the 4608C the measured offset value is 0.6 mV and the temperature coefficient is 0.1 mV/°C. The power supply coefficient is negligible because the -5.3 V lines are stabilized on board.

Threshold Hysteresis

The 4608C discriminator has 3.5 mV hysteresis built into the front end. Every threshold crossing will not trigger the discriminator unless the previous signal has returned to below, for example, approximately -26.5 mV for threshold setting of -30 mV. This feature avoids multiple pulsing due to fine structure riding on a flat-topped pulse that may bring the pulse above and below threshold. Two examples below in Figure 5 illustrate this point.

In Example A of Figure 5 the input pulse will not retrigger the discriminator, if set for -30 mV threshold, even though it crosses the threshold level at a time exceeding the Double Pulse Resolution (DPR) of the unit.

In example B, the input signal does go back through the threshold of -30 mV but goes beyond to exceed the threshold plus hysteresis level. Two discriminator output pulses would result.

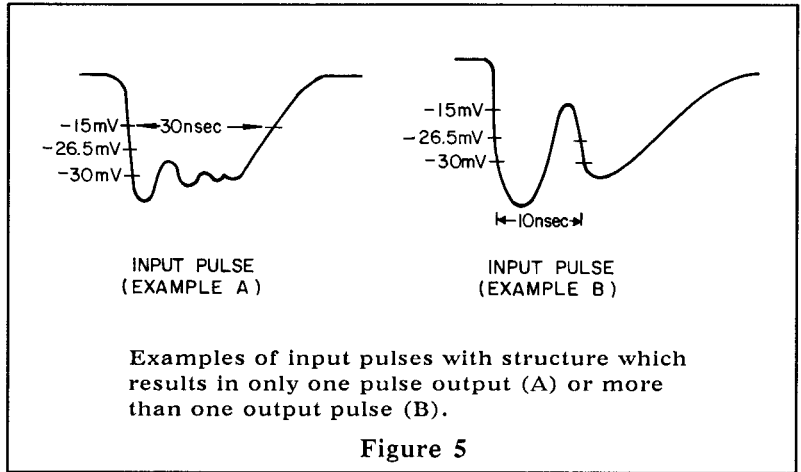

Since LeCroy discriminators are most often used with photomultipliers and plastic scintillators, and since the characteristic pulses out of this type of detector are typically smooth for each individual event, multiple outputs should only occur when they represent multiple events.

MINIMUM INPUT CHARGE

The 4608C requires a minimum input charge above the threshold to trigger. As a result, the discriminator threshold is input pulse width dependent which is more apparent with shorter input widths.

The following diagram (Figure 6) shows a typical threshold behavior as function of the input pulse width at 100 mV nominal threshold. The input pulse widths given have been measured at the half maximum.

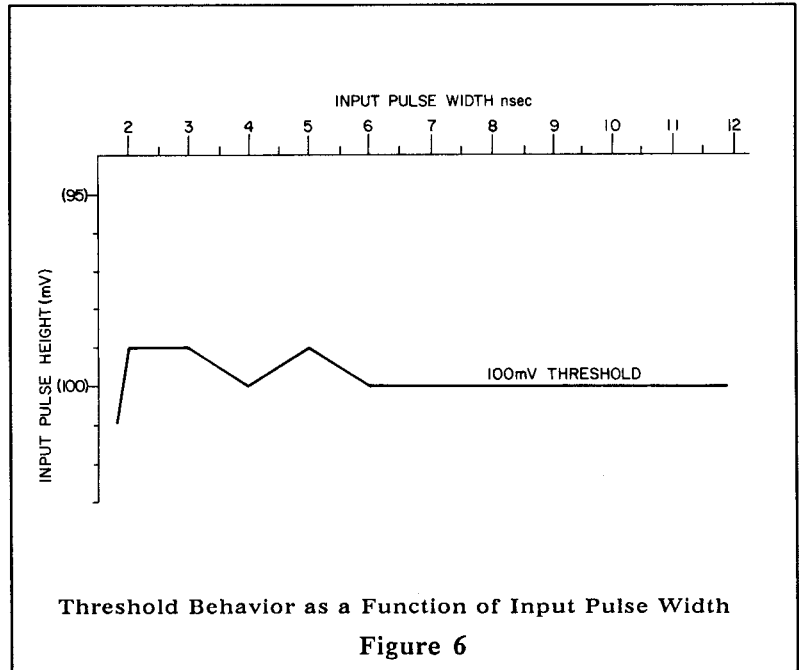

OUTPUT WIDTH

The output of a discriminator is a logic pulse which can be used for various functions and purposes in the rest of the system. The output pulse width must be compatible with the equipment following the discriminator. However, the maximum repetition rate of the unit is limited by this width. Therefore, certain trade-offs may have to be made in determining the required output width.

The output width in the standard Updating mode is adjustable via a front-panel potentiometer. The width adjustment can be monitored by using a scope connected to one of the module's output connectors. Width is increased as the control is turned clockwise.

The output width in the Burst Guard mode will either be equivalent to the time over threshold of the input pulse or the preset width, whichever is greater.

TEST MODE

The 4608C permits rapid testing of output width for all discriminator channels as well as the module in general by simulating eight inputs which exceed threshold.

To initiate TEST, a negative NIM level is applied to the front-panel connector. Connections to the signal inputs need not be

removed. All channels will produce an output with duration equal to that of the preset width in the Updating mode and equal to duration of the TEST input pulse in the Burst Guard mode. The TEST function is also useful for checking other units in the system following the discriminator.

INTRODUCTION

The operation of the 4608C can be divided into six separate sections: Discriminator, Width Control, Threshold, Veto, Test, and Power Distribution. Each section is described below.

Discriminator

Most of the discriminator circuitry for two channels is contained in a single LeCroy hybrid HVL210. The hybrid, based on LeCroy's monolithic comparator MVL407, contains schematically the comparator, the Vetoing circuitry as well as the circuitry for the modes of operation (Updating and Burst Guard) and a one shot. Inputs to the unit are negative going signals which are directly coupled to the hybrid. Outputs of the hybrids are converted into NIM levels (Q1 through Q16) and connected to front-panel Lemo connectors.

Width Control

Individual Width Controls are provided for each of the eight channels and are adjusted by front-panel 2 k Ω potentiometers (P1-P8) referenced between ground and -5.3 V. These controls are then connected directly to the hybrids.

Threshold

Threshold adjustment is provided by front-panel 1 k Ω potentiometers (P9-P16) for each of the eight channels and are referenced between ground on -5.3 V. Following the controls are unity gain amplifiers which are connected to the threshold monitor and to the positive input pins of the hybrids.

Veto

The Veto input acts simultaneously on all eight channels. The NIM level input signal is first translated into ECL level signal (Q17 on sheet 1 of the schematics) and distributed to all the channels.

Test

The Test input acts simultaneously on all channels. The NIM level signal is first amplified (transistors Q20 and Q21 both A401) and then injected by transistors Q18 and Q19 into a low impedance line distributing the signal to all the hybrids.

Power Distribution

In order to eliminate the output width variation as a function of the power supply and to provide a low current generator needed for the maximum output width, the -5.3 V line is regulated and filtered on board by a LM301AN (C2) and N-channel SIPMOS transistor BUZ10(C1) in sheet 2 of the schematics. The -2 V is obtained from the -6 V line with a LM337T(C3). Power consumption for each input voltage are as follows:

-6 V	2.1 A
+6 V	0.6 A
-24 V	0.01 A

INDEX

Burst Guard Mode	7,9	Signal Input Specifications	6 4
Coefficients of Temperature Controls and Connectors	9,13 7	Test	17
Discriminator	17	Test Input	4,7
Double pulse Resolution	4	Test Mode	15
Hysteresis	13	Theory of Operation	17
Input Characteristics	4	Threshold	6,13,17
Installation	11	Threshold Monitor	4,7
Minimum Input Charge	14	Threshold Uncertainty	13
Operating Instruction	13	Time Slewing	5
Output	8	Timing Characteristics	4
Output Characteristics	4	Tracking Error	5
Output Width	15	Unpacking and Inspection	1
Overview	3	Updating Mode	7,9
Power Distribution	17	Veto	17
Power Requirements	5,11	Veto Input	7
Product Assistance	2	Warranty	1
		Width Adjustment	9
		Width Control	17